

FEATURES/BENEFITS

- Latest generation MOSFET technology
- Ultra low on-state resistance
- Low output leakage current
- Built-in overvoltage protection
- Reverse protected triggered control input to avoid linear control risks
- No radiated or conducted disturbances
- IP20 touch-proof flaps



IP20 touch-proof flaps

Part Number	Description
SH10DC40	40A, 100 Vdc Solid-State Relay
SH10DC40-16	40A, 60 Vdc Solid-State Relay
SH20DC20-16	20A, 200 Vdc Solid-State Relay
SH20DC40-16	40A, 200 Vdc Solid-State Relay
SH75DC60-16	60A, 75 Vdc Solid-State Relay

Part Number Explanation

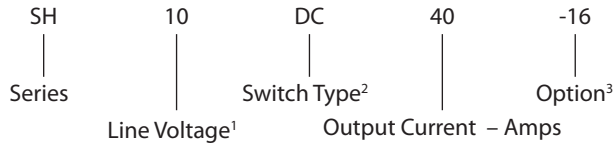

NOTES

- 1) Line Voltage (peak): 10 = 100 Vdc
- 2) Switch Type: DC = DC
- 3) Option: Internal Voltage Protection

ELECTRICAL SPECIFICATIONS
(+25°C ambient temperature unless otherwise specified)

INPUT (CONTROL) SPECIFICATIONS

	Min	Max	Units
Control Range	3.5	32	Vdc
Must Turn-Off Voltage	1		Vdc
Reverse Voltage		32	Vdc

CONTROL CHARACTERISTIC

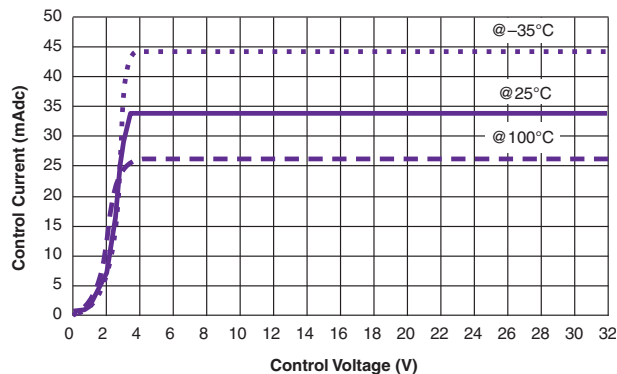
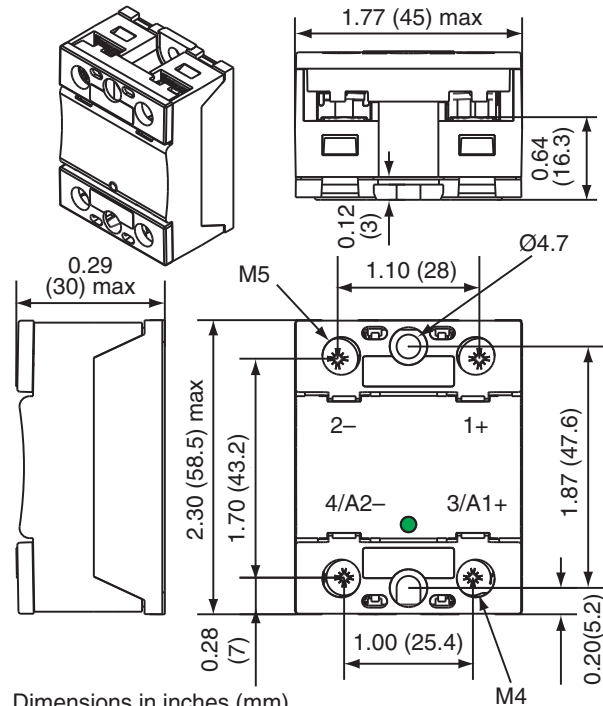

Figure 2

MECHANICAL SPECIFICATION



Dimensions in inches (mm)
Weight: 2.82 oz. (80g)

Figure 1

BLOCK DIAGRAM

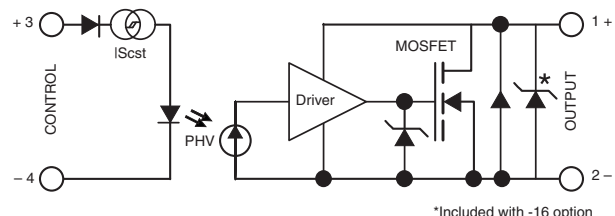

*Included with -16 option

Figure 3

ELECTRICAL SPECIFICATIONS
(+25°C ambient temperature unless otherwise specified)

OUTPUT (LOAD) SPECIFICATIONS

	Min	Max	Units
Operating Range			
SH10DC40	5	100	Vdc
SH10DC40-16	5	60	Vdc
SH20DC20-16	5	110	Vdc
SH20DC40-16	5	110	Vdc
SH75DC60-16	5	40	Vdc
Peak Voltage			
SH10DC40		100	Vdc
SH10DC40-16		100	Vdc
SH20DC20-16		200	Vdc
SH20DC40-16		200	Vdc
SH75DC60-16		75	Vdc
Overvoltage Protection (Built-In)			
SH10DC40-16		56V (TVS) ¹	
SH20DCXX-16		75V (MOV Size 20) ²	
SH75DC60-16		39V (TVS) ¹	
1) Transient Voltage Suppressor; 2) Metal Oxide Varistor			
Reverse Voltage Drop			
SH10DC40-16		1.3	V
SH20DCXX-16		1.5	V
SH75DC60-16		0.92	V
Nominal Current (Resistive)			
SH10		40	A
SH20DC20-16		20	A
SH20DC40-16		40	A
SH75DC60-16		60	A
Non-Repetitive Peak Overload Current			
SH10		320	A
SH20DC20-16		160	A
SH20DC40-16		380	A
SH75DC60-16		750	A
Leakage Current			
		3	mA
On-State Resistance (@ 25°C)			
	@25 °C	@125 °C	
SH10	15	30	mΩ
SH20DC20-16	45	90	mΩ
SH20DC40-16	23	46	mΩ
SH75DC60-16	4.5	8.2	mΩ

ELECTRICAL SPECIFICATIONS (continued)
(+25°C ambient temperature unless otherwise specified)

OUTPUT (LOAD) SPECIFICATIONS

	Min	Max	Units
Output Capacitance (Typical)			
SH10	0.7		nF
SH20DC20-16	0.6		nF
SH20DC40-16	1.1		nF
SH75DC60-16	1.5		nF
Junction-Case Thermal Resistance			
SH10		0.9	°C/W
SH20DC20-16		1.2	°C/W
SH20DC40-16		0.7	°C/W
SH75DC60-16		1.2	°C/W
Built-In Heat Sink Thermal Resistance (Vertically Mounted)			
		10	°C/W
Heat Sink Thermal Time Constant			
		10	min
Control Inputs/Power Outputs			
Insulation Voltage			
		2.5	kV
Turn-On Time			
		20	μs
Turn-On Delay			
		20	μs
Turn-Off Time			
		20	μs
Turn-Off Delay			
		20	μs
On-Off Frequency			
		1000*	Hz

*For high frequency, take two times the load current to calculate the heat sink.

TIME DIAGRAMS

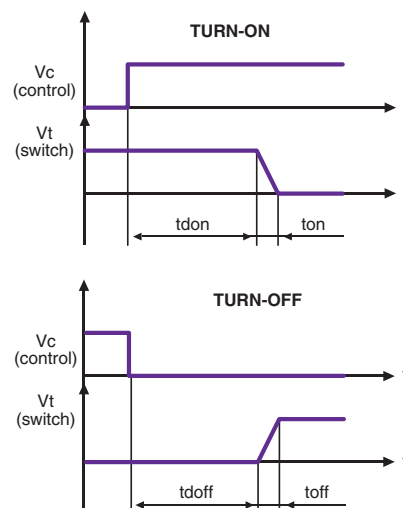
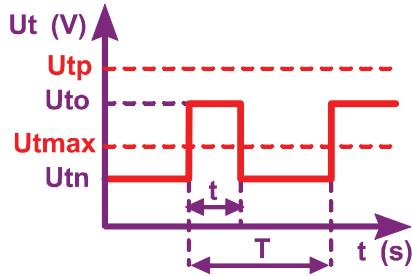

Figure 4

BUILT IN OVERVOLTAGE PROTECTION CHARACTERISTICS



$$U_{to} < U_{tp}$$

$$t_{max} = \frac{0.75}{(U_{to} - U_{tmax}) \times I_e}$$

$$P_{(protection)} = I W_{max}$$

$$\Rightarrow \frac{(U_{to} - U_{tmax}) \times I_e \times t}{T} \leq 1$$

- I_{elk} : Leakage current of relay
- I_e : User load nominal current
- U_{tp} : Relay max. non repetitive peak voltage
- U_{tmax} : Max. nominal voltage of relay

- U_{to} : Possible overvoltage above U_{tmax}
- U_{tn} : User power supply voltage
- t : Overvoltage duration
- T : Time between 2 overvoltages

SH10DC40-16

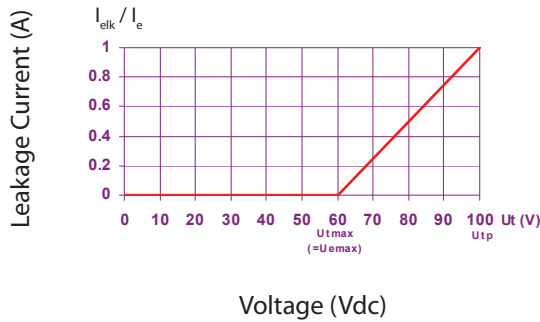

Figure 5a

SH20DC20-16 & SH20DC40-16

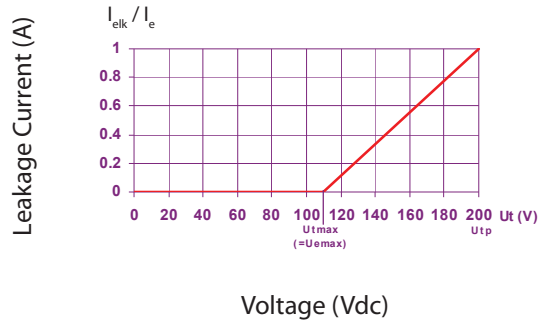

Figure 5b

SH75DC-16

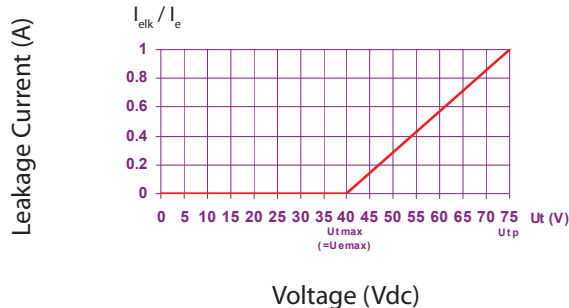

Figure 5c

HIGH SIDE WIRING DIAGRAM
(Load Connected to “—”)

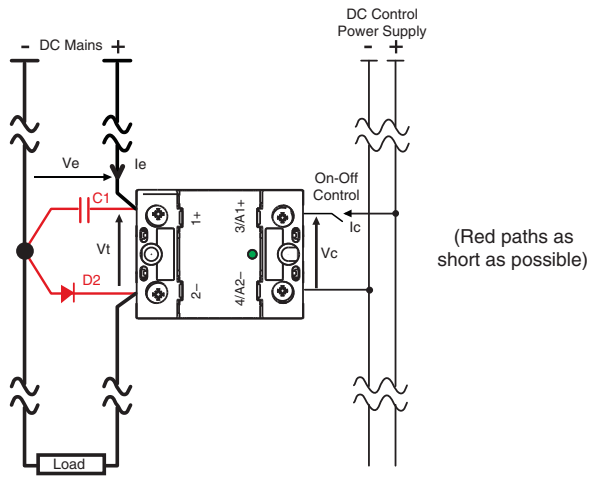

Figure 6a

LOW SIDE WIRING DIAGRAM
(Load Connected to “+”)

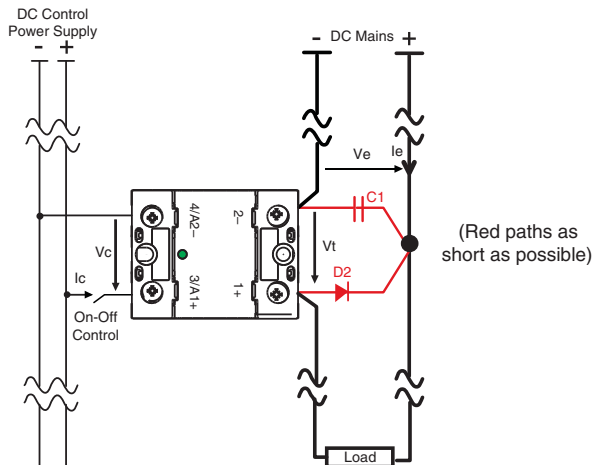

Figure 6b

GENERAL SPECIFICATIONS
(+25°C ambient temperature unless otherwise specified)

ENVIRONMENTAL SPECIFICATIONS

	Min	Max	Units
Operating Temperature	-25	+90	°C
Storage Temperature	-40	+100	°C
Input-Output Isolation		2.5	kV
Insulation Resistance	1		GΩ
Insulation Capacitance	8		pF
Junction Temperature			
Steady State		125	°C
Transient		175	°C
Case Temperature		100	°C

CONNECTIONS

	Power	Control
Screwdriver	POZIDRIV2	
Tightening Torque	2 N.m	1.2 N.m
Insulated crimp terminals (Round Tabs, Eyelet Type)	M5	M4

MISCELLANEOUS

Display	Green LED (ON)
Housing	UL94V0
Mounting	2 screws (M4x12mm)
Noise Level	No audible noise

GENERAL

Standards	IEC60947-1
Protection Level	IP20
Protection Against Direct Touch	Yes
CE Marking	Yes

E.M.C. EMISSION

Radiated & Conducted Disturbances Pending

ACCESSORIES

Faston: Contact Factory



NOTES

1. For additional/custom options, contact factory.

OUTPUT RELAY CHARACTERISTIC CURVES FOR SH10DC40 & SH10DC40-16

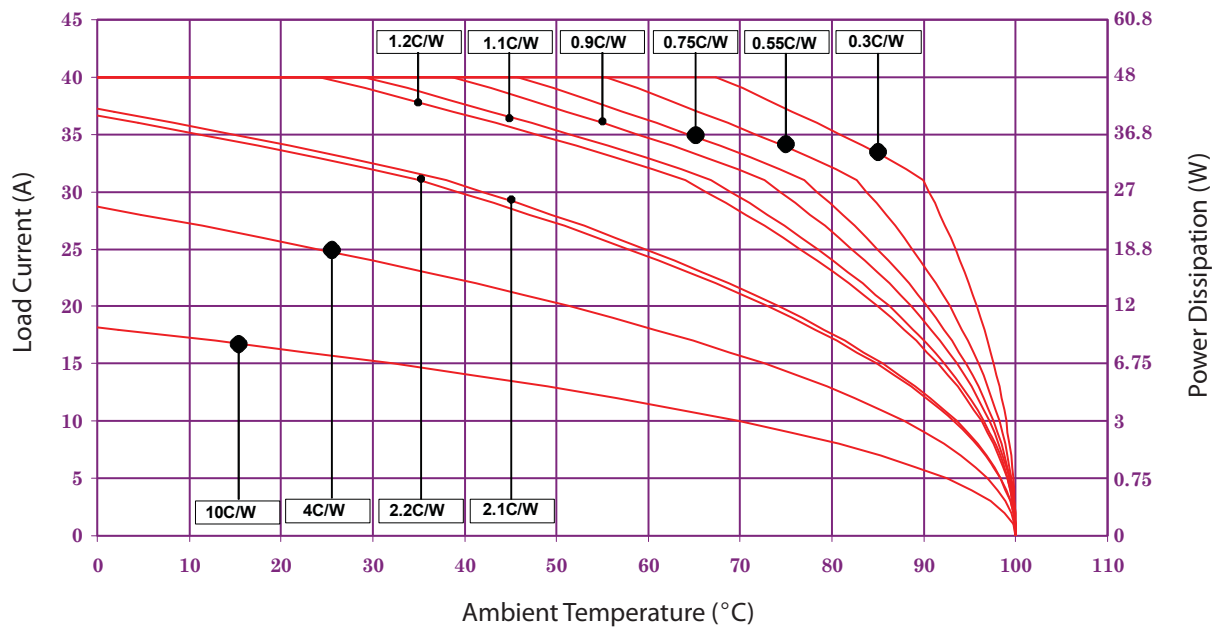

Figure 7a

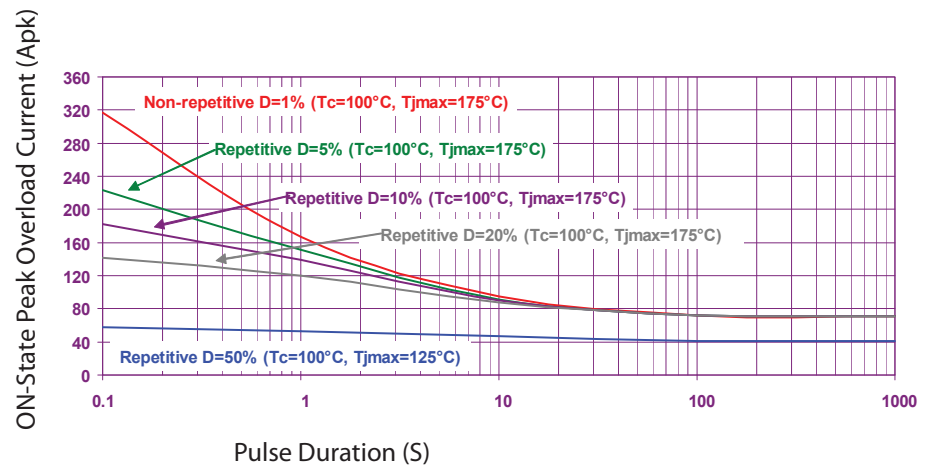
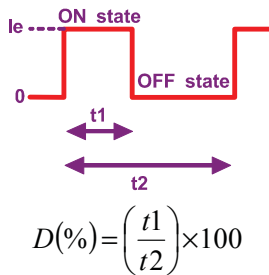

Figure 7b

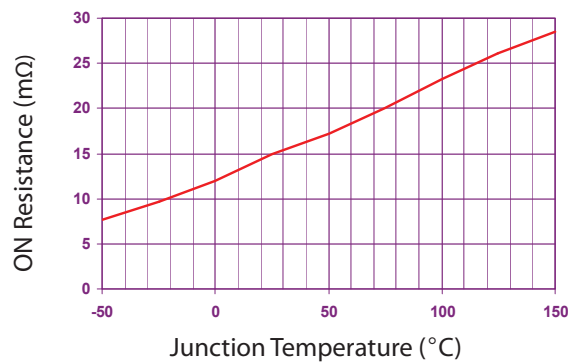

Figure 7c

OUTPUT RELAY CHARACTERISTIC CURVES FOR SH20DC20-16

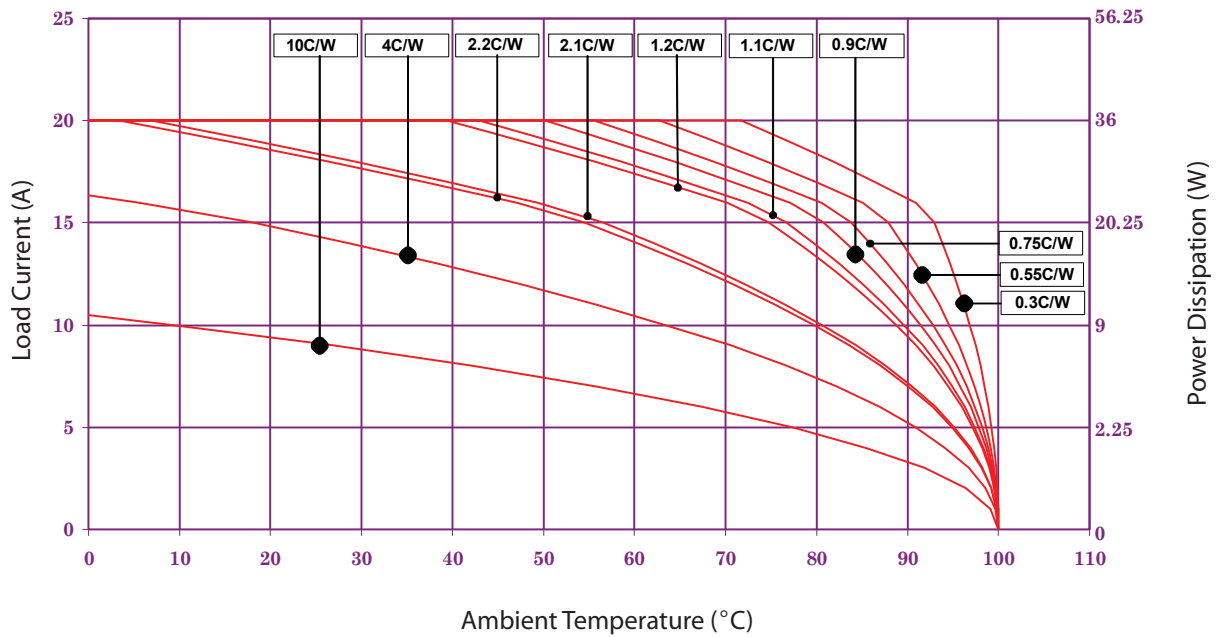

Figure 8a

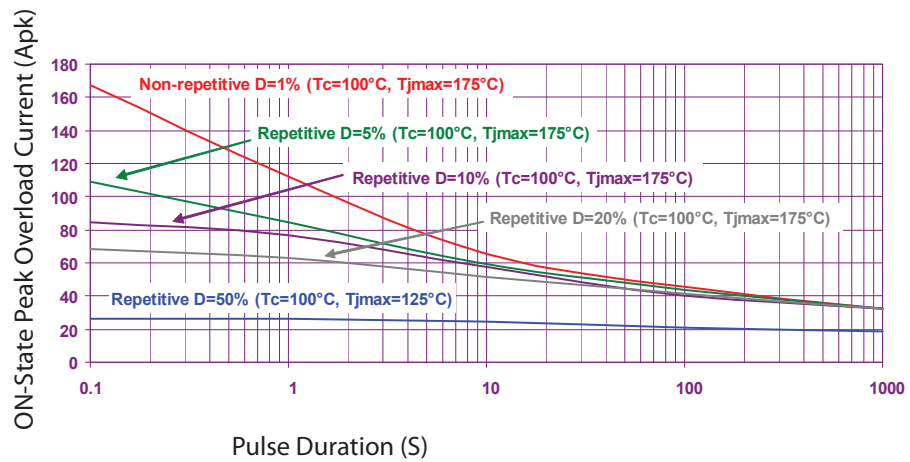
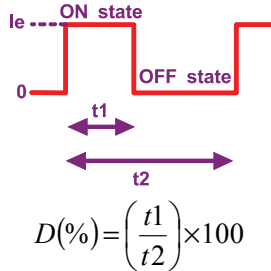

Figure 8b

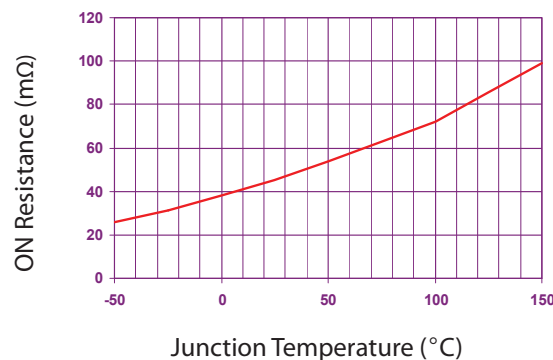

Figure 8c

OUTPUT RELAY CHARACTERISTIC CURVES FOR SH20DC40-16

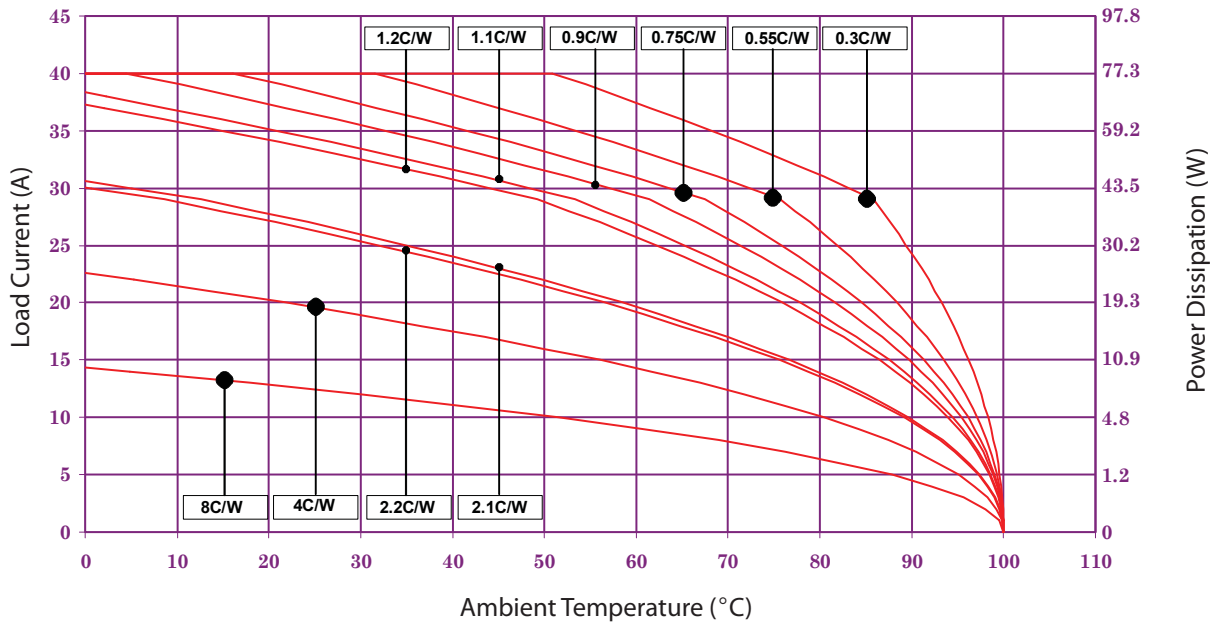

Figure 9a

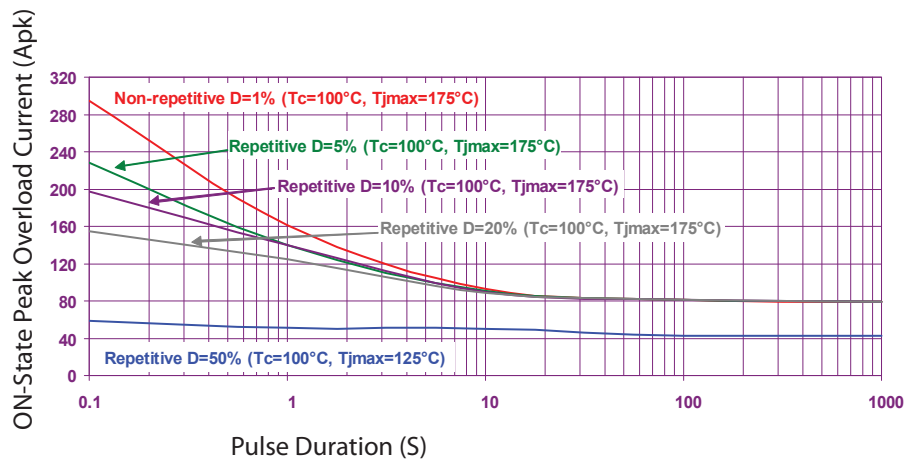
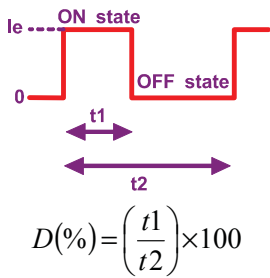

Figure 9b

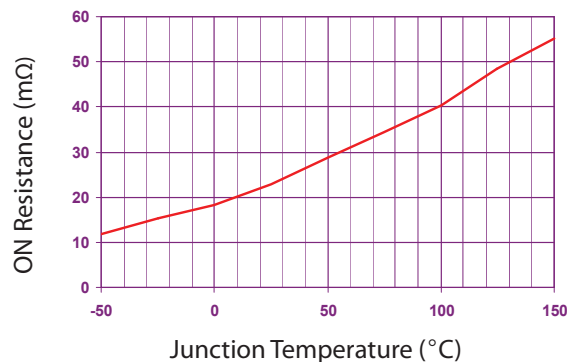

Figure 9c