

TOSHIBA CMOS Integrated Circuits Silicon Monolithic**TCA62723FMG****Three-Channel Constant-Current LED Driver**

The TCA62723FMG is an optimal constant-current LED driver for RGB pixel LEDs.

This IC does not have to connect external resistance to each output in the case of most. The output current of 3ch is set up by one external resistance.

Features

- Power supply voltage range : 2.7 to 5.5 V
- Constant current range : 5 to 150 mA
- Low consumption current
 - At the time of IC operation mode (I_{out} = 20 mA/DC) : 700 μ A (MAX)
 - At the time of IC power-saving mode : 10 μ A (MAX)
- For anode common LED
- Package : SON10-P-0303-0.50

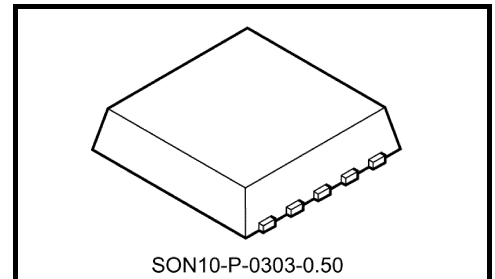

Weight: 0.018 g (typ.)

Pin Layout (Top view)

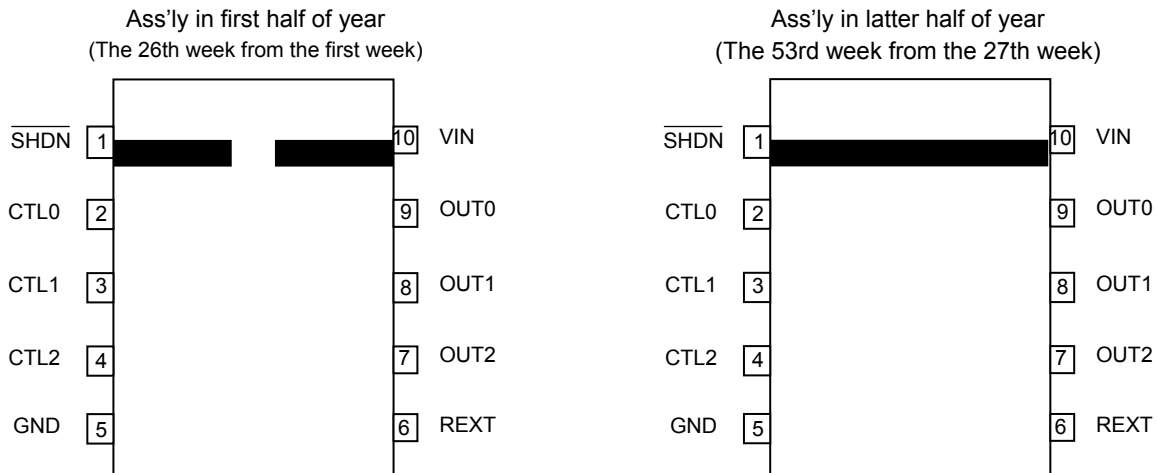

Terminal Description

Pin No.	Pin Name	Function
1	$\overline{\text{SHDN}}$	The shutdown signal input terminal. In the case of "L" level input, the IC becomes the power-saving mode. In the case of "H" level input, the IC becomes the operation mode.
2	CTL0	The ON/OFF control signal of OUT0 Input terminal. In the case of "L" level input, OUT0 is turned OFF. In the case of "H" level input, OUT0 is turned ON.
3	CTL1	The ON/OFF control signal of OUT1 Input terminal. In the case of "L" level input, OUT1 is turned OFF. In the case of "H" level input, OUT1 is turned ON.
4	CTL2	The ON/OFF control signal of OUT2 Input terminal. In the case of "L" level input, OUT2 is turned OFF. In the case of "H" level input, OUT2 is turned ON.
5	GND	Grand terminal.
6	REXT	The output current setting resistor connection terminal. Resistance is connected with this terminal between GND. The output current does not flow when this terminal is opened. Excessive output current will destroy the IC if this terminal is connected to GND.
7	OUT2	Constant current output terminal.
8	OUT1	
9	OUT0	
10	VIN	Supply voltage input terminal.

Block Diagram

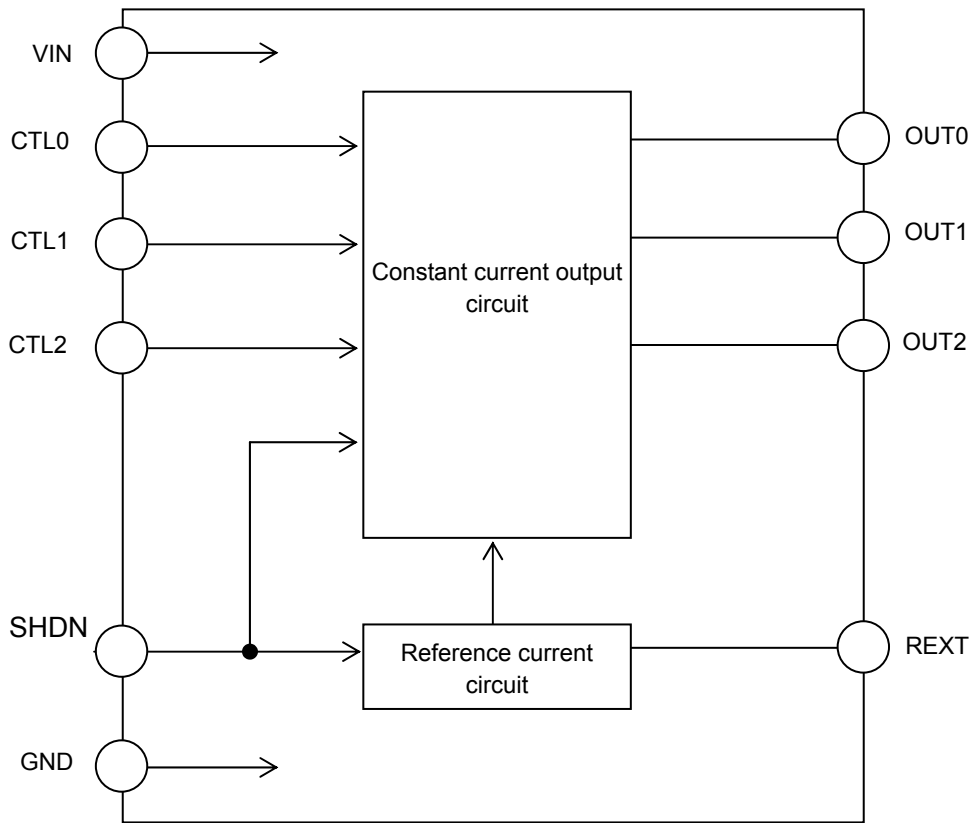

Application Circuit Example

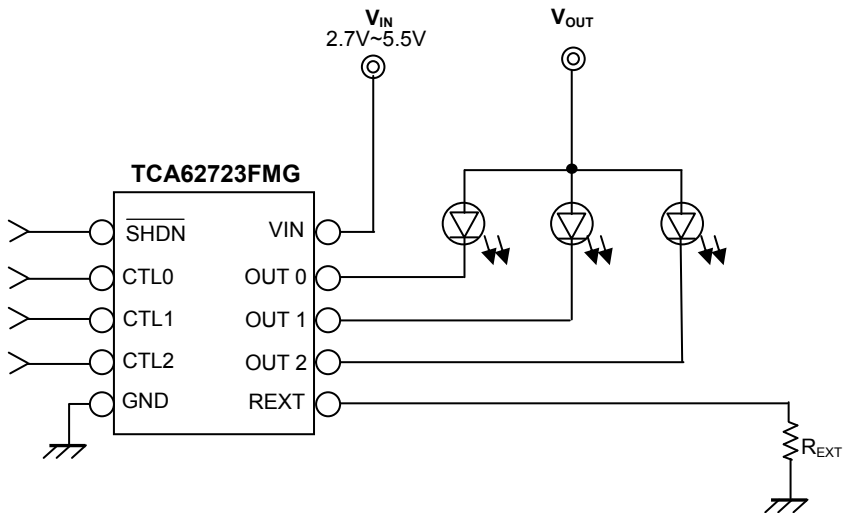

Method of setting output current (Reference data)

The output current is set by R_{EXT} connected with the terminal $REXT$.

$$I_{OUT} \text{ (mA)} = \frac{1.17 \text{ (V)}}{R_{EXT} \text{ (k}\Omega)} \times 460$$

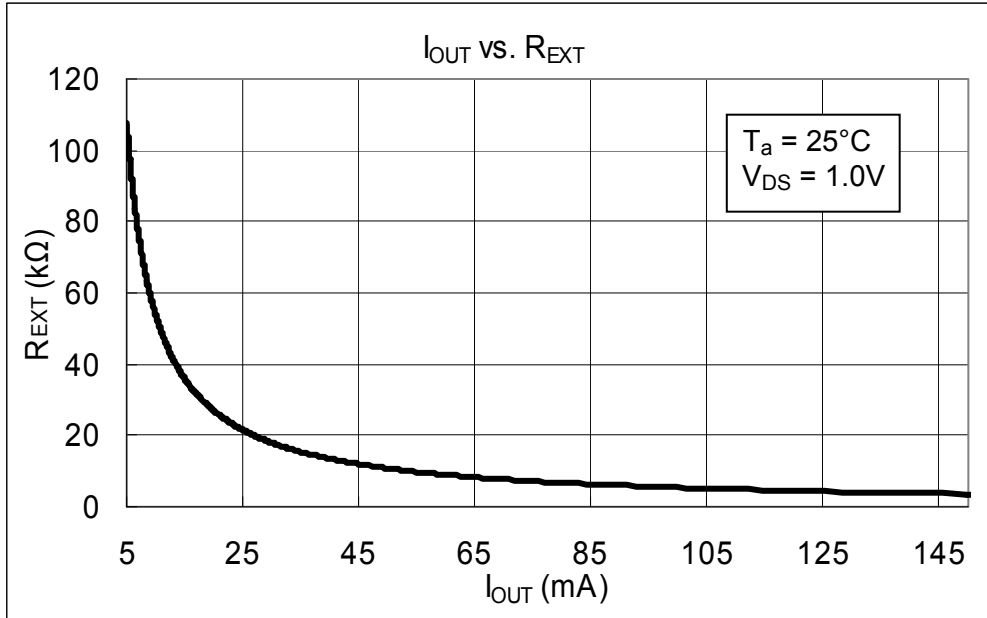

Output Voltage – Output Current (Reference data)

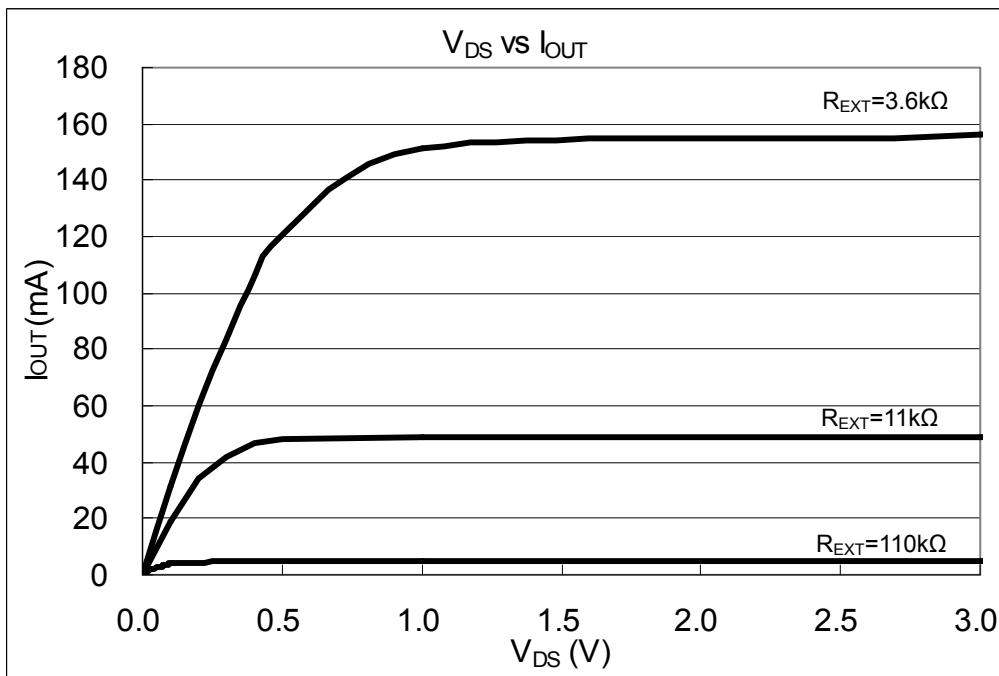

Note: These application examples are provided for reference only. Thorough evaluation and testing should be implemented when designing your application's mass production design.

Output Current Dimming Control

1) Method of inputting analog voltage to terminal REXT

1. Precondition
Please set the range of the analog voltage input by 0 to 1.17V.

2. The maximum current is defined as α mA. ($V_{ADJ}=0V$)

$$\alpha = 1.17 \times \frac{R_1 + R_{EXT}}{R_1 \times R_{EXT}} \times 460$$

3. The minimum current is defined as β mA. ($V_{ADJ}=1.17V$)

$$\beta = 1.17 \times \frac{1}{R_{EXT}} \times 460$$

4. I_{OUT} can be set according to the next expression.

$$I_{OUT} = V_{ADJ} \times \frac{\beta - \alpha}{1.17} + \alpha$$

(Example) Current Dimming from $I_{OUT}=120mA$ to $60mA$ (Reference data)

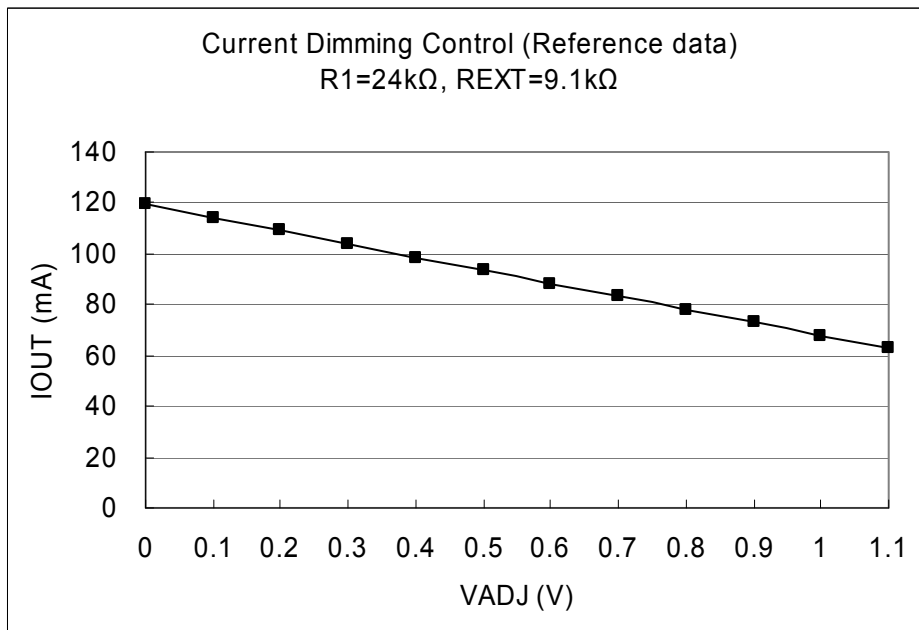
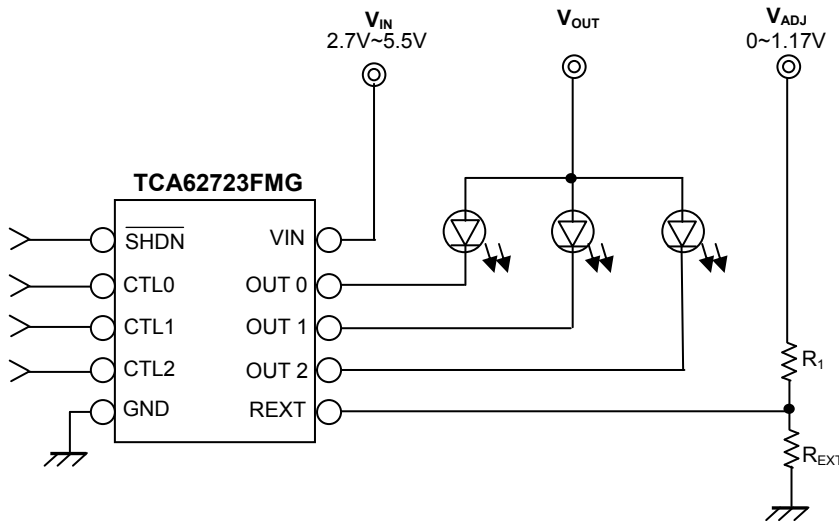

Note: These application examples are provided for reference only. Thorough evaluation and testing should be implemented when designing your application's mass production design.

2) Method of inputting PWM signal to terminal REXT

I_{OUT} can be set according to the next expression.

$$I_{OUT} = \left[\frac{1.17V + \frac{(1.17V - V_{CONT}) \times R_{EXT}}{R_{CONT}}}{R_{EXT}} \right] \times 460$$

V_{CONT} = D × V_{PWM} D: PWM Duty (%)

R_{CONT} = R₁ + R₂

Please define the cutoff frequency to the next expression. (f_C ≤ f_{PWM})

$$f_C = \frac{1}{2 \times \pi \times R \times C}$$

$$R = \frac{R_1 \times R_2}{R_1 + R_2}$$

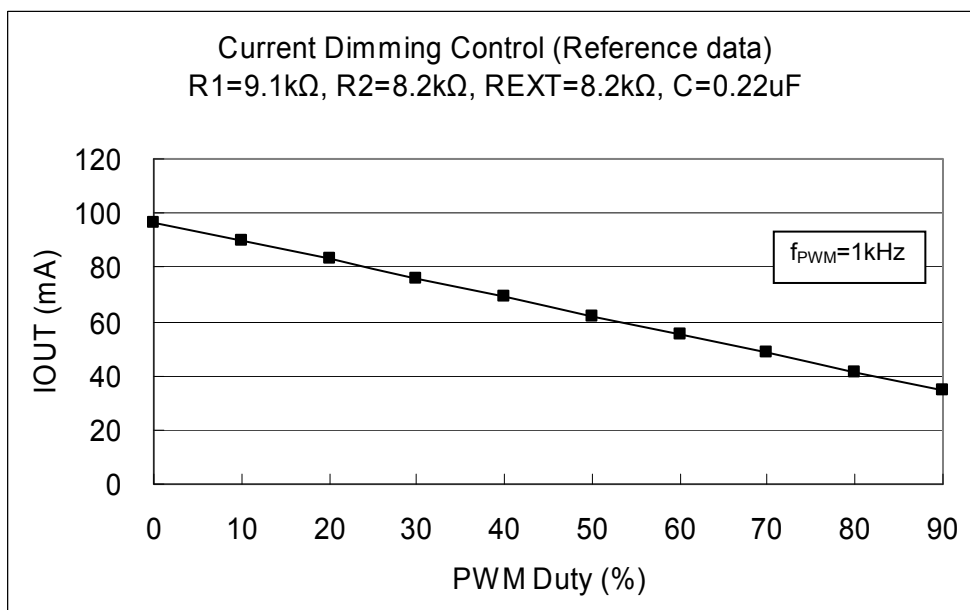
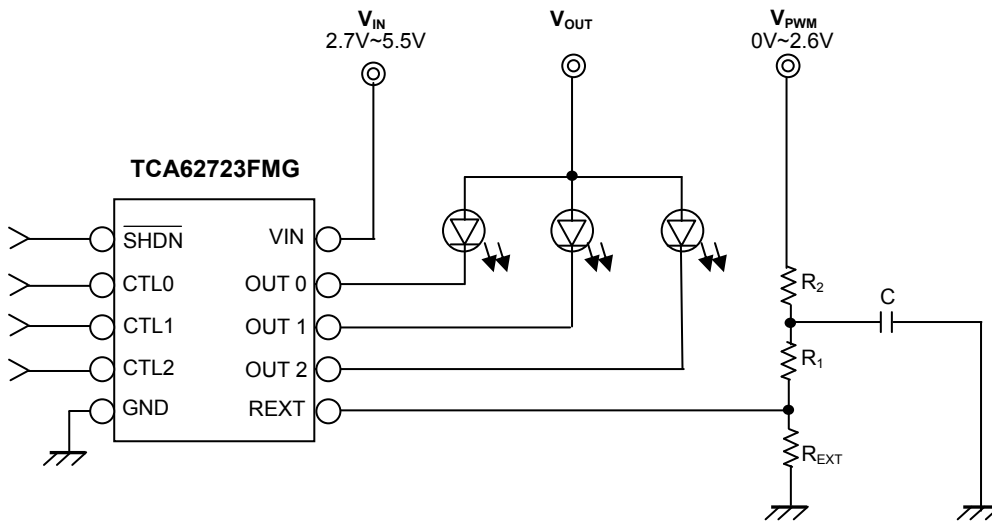

Note: These application examples are provided for reference only. Thorough evaluation and testing should be implemented when designing your application's mass production design.

Absolute Maximum Ratings (T_a = 25°C)

Characteristic	Symbol	Ratings *1	Unit
Supply voltage	V _{IN}	-0.3 ~ +6.0	V
Output voltage	V _{OUT}	-0.3 ~ +6.0	V
Input voltage (CTL0/CTL1/CTL2/ $\overline{\text{SHDN}}$ Terminal)	V _{IN}	-0.3 ~ V _{IN} +0.3 *2	V
Power dissipation	P _D	0.36 (free air)	W
		0.79 (on PCB) *3,4	
Thermal resistance	R _{th(j-a)}	340 (free air)	°C/W
		158 (on PCB) *3	
Operating temperature	T _{opr}	-40 ~ +85	°C
Storage temperature	T _{stg}	-55 ~ +150	°C
Maximum junction temperature	T _j	150	°C

Note1: Voltage is ground referenced.

Note2: Do not exceed 6.0V.

Note3: PCB condition 40 mm x 40 mm x 1.6 mm, Cu = 10 %

Note4: The power dissipation decreases the reciprocal of the saturated thermal resistance (1/R_{th(j-a)}) for each degree (1°C) that the ambient temperature is exceeded (T_a = 25°C).

Operating Conditions

Characteristic	Symbol	Condition	Min	Typ.	Max	Unit
Supply voltage	V _{IN}	-	2.7	3.6	5.5	V
Constant current output	I _{OUT}	OUT0 to OUT2	5	-	150	mA/ch
R _{EXT} resistance	R _{EXT}	-	3.6	-	110	kΩ
CTL terminal minimum pulse width	t _{CTL}	R _{EXT} =11kΩ	25	-	-	μs

Electrical Characteristics (unless otherwise specified, V_{IN} = 3.6 V, T_a = 25°C)

Characteristic	Symbol	Condition	Min	Typ	Max	Unit
Supply voltage	V _{IN}	-	2.7	3.6	5.5	V
Supply current (IC operation)	I _{IN} (On)	R _{EXT} = 27.6kΩ	-	-	700	μA
Supply current (IC standby)	I _{IN} (Off)	$\overline{\text{SHDN}}$ = L	-	-	10	μA
Input voltage	High level	Measuring terminal is CTL0, CTL1, CTL2, $\overline{\text{SHDN}}$	0.7V _{IN}	-	V _{IN} +0.15V	V
	Low level		-0.15	-	0.3V _{IN}	
Input current	I _{IH}	Measuring terminal is CTL0, CTL1, CTL2, $\overline{\text{SHDN}}$	-1.0	-	1.0	μA
	I _{IL}		-1.0	-	1.0	
Gain (I _{OUT} / I _{R_{EXT}})	GAIN	R _{EXT} = 11 kΩ	359	460	560	A/A
R _{EXT} terminal voltage	V _{REXT}	V _{IN} =3.6 V, R _{EXT} = 11 kΩ	1.09	1.17	1.25	V
Output leakage current	I _{OZ}	$\overline{\text{SHDN}}$ = "L", V _{OUT} = 5.5 V	-	-	0.1	μA
Constant current accuracy	dI _{OUT}	V _{IN} = 3.6 V, R _{EXT} = 11 kΩ	-	±1	±7.5	%
Time from $\overline{\text{SHDN}}$ release to start of operation	t _{RE}	-	-	2	5	ms

Switching characteristics (unless otherwise specified, $V_{IN} = 3.6\text{ V}$, $T_a = 25^\circ\text{C}$)

Characteristic	Symbol	Condition	Min	Typ	MAX	Unit
Propagation delay	t_{pLH}	$R_{EXT}=11\text{k}\Omega$, Voltage waveform	-	50	-	ns
	t_{pHL}	$R_{EXT}=11\text{k}\Omega$, Voltage waveform	-	1	-	μs
Rise time	t_R	$R_{EXT}=11\text{k}\Omega$, Voltage waveform	-	50	-	ns
Fall time	t_F	$R_{EXT}=11\text{k}\Omega$, Voltage waveform	-	1	-	μs

Note: $T_a=25^\circ\text{C}$, $V_{IH}=V_{IN}$, $V_{IL}=0\text{V}$, $V_{OUT}=2.0\text{V}$, $R_L=20\Omega$, $C_L=10.5\text{pF}$

Test Circuit

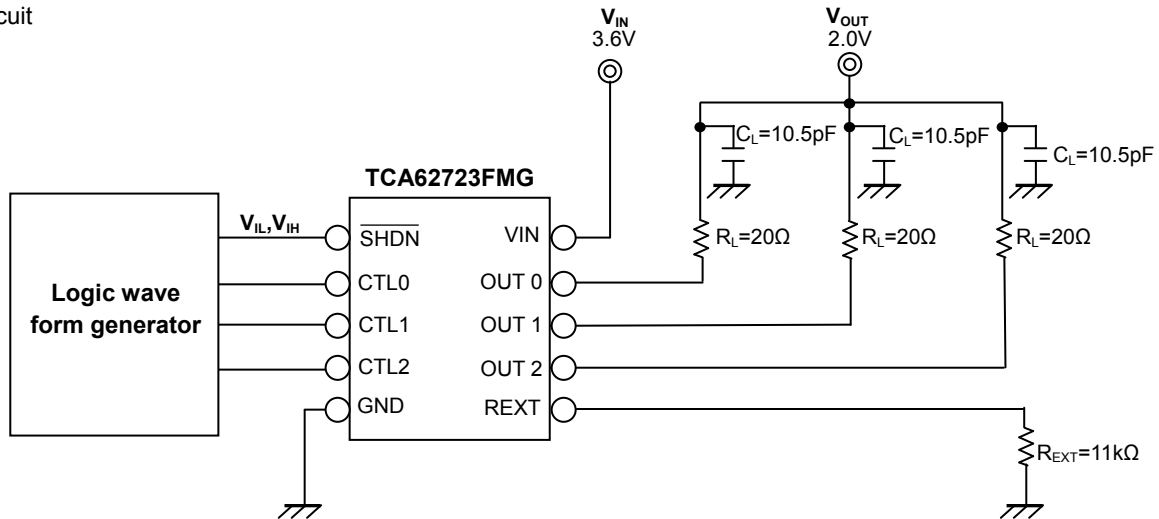

Package Dimensions

SON10-P-0303-0.50

Unit: mm

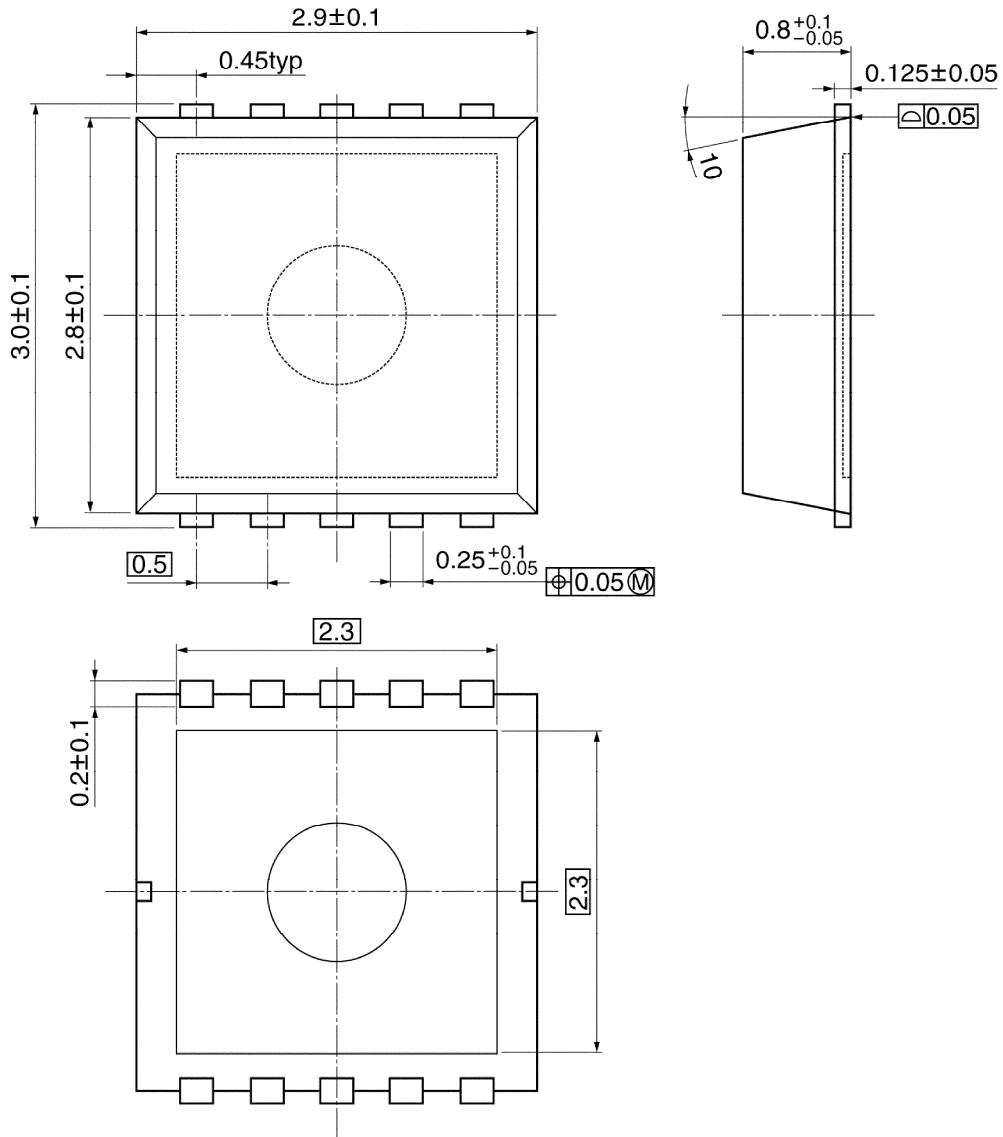

Weight: 0.018 g (typ.)

Notes on Contents

1. Block Diagrams

Some of the functional blocks, circuits, or constants in the block diagram may be omitted or simplified for explanatory purposes.

2. Equivalent Circuits

The equivalent circuit diagrams may be simplified or some parts of them may be omitted for explanatory purposes.

3. Timing Charts

Timing charts may be simplified for explanatory purposes.

4. Application Circuits

The application circuits shown in this document are provided for reference purposes only. Thorough evaluation is required, especially at the mass production design stage.

Toshiba does not grant any license to any industrial property rights by providing these examples of application circuits.

5. Test Circuits

Components in the test circuits are used only to obtain and confirm the device characteristics. These components and circuits are not guaranteed to prevent malfunction or failure from occurring in the application equipment.

IC Usage Considerations

Notes on handling of ICs

[1] The absolute maximum ratings of a semiconductor device are a set of ratings that must not be exceeded, even for a moment. Do not exceed any of these ratings.

Exceeding the rating(s) may cause the device breakdown, damage or deterioration, and may result injury by explosion or combustion.

[2] Use an appropriate power supply fuse to ensure that a large current does not continuously flow in case of over current and/or IC failure. The IC will fully break down when used under conditions that exceed its absolute maximum ratings, when the wiring is routed improperly or when an abnormal pulse noise occurs from the wiring or load, causing a large current to continuously flow and the breakdown can lead smoke or ignition. To minimize the effects of the flow of a large current in case of breakdown, appropriate settings, such as fuse capacity, fusing time and insertion circuit location, are required.

[3] If your design includes an inductive load such as a motor coil, incorporate a protection circuit into the design to prevent device malfunction or breakdown caused by the current resulting from the inrush current at power ON or the negative current resulting from the back electromotive force at power OFF. IC breakdown may cause injury, smoke or ignition.

Use a stable power supply with ICs with built-in protection functions. If the power supply is unstable, the protection function may not operate, causing IC breakdown. IC breakdown may cause injury, smoke or ignition.

[4] Do not insert devices in the wrong orientation or incorrectly.

Make sure that the positive and negative terminals of power supplies are connected properly.

Otherwise, the current or power consumption may exceed the absolute maximum rating, and exceeding the rating(s) may cause the device breakdown, damage or deterioration, and may result injury by explosion or combustion.

In addition, do not use any device that is applied the current with inserting in the wrong orientation or incorrectly even just one time.

[5] Carefully select external components (such as inputs and negative feedback capacitors) and load components (such as speakers), for example, power amp and regulator.

If there is a large amount of leakage current such as input or negative feedback condenser, the IC output DC voltage will increase. If this output voltage is connected to a speaker with low input withstand voltage, overcurrent or IC failure can cause smoke or ignition. (The over current can cause smoke or ignition from the IC itself.) In particular, please pay attention when using a Bridge Tied Load (BTL) connection type IC that inputs output DC voltage to a speaker directly.

Points to remember on handling of ICs**(1) Heat Radiation Design**

In using an IC with large current flow such as power amp, regulator or driver, please design the device so that heat is appropriately radiated, not to exceed the specified junction temperature (T_J) at any time and condition. These ICs generate heat even during normal use. An inadequate IC heat radiation design can lead to decrease in IC life, deterioration of IC characteristics or IC breakdown. In addition, please design the device taking into consideration the effect of IC heat radiation with peripheral components.

(2) Back-EMF

When a motor rotates in the reverse direction, stops or slows down abruptly, a current flows back to the motor's power supply due to the effect of back-EMF. If the current sink capability of the power supply is small, the device's motor power supply and output pins might be exposed to conditions beyond maximum ratings. To avoid this problem, take the effect of back-EMF into consideration in system design.

About solderability, following conditions were confirmed
Solderability

- (1) Use of Sn-37Pb solder Bath
solder bath temperature: 230°C
dipping time: 5 seconds
the number of times: once
use of R-type flux
- (2) Use of Sn-3.0Ag-0.5Cu solder Bath
solder bath temperature: 245°C
dipping time: 5 seconds
the number of times: once
use of R-type flux

RESTRICTIONS ON PRODUCT USE

- This document and any information herein may not be reproduced without prior written permission from TOSHIBA. Even with TOSHIBA's written permission, reproduction is permissible only if reproduction is without alteration/omission.
- Though TOSHIBA works continually to improve Product's quality and reliability, Product can malfunction or fail. Customers are responsible for complying with safety standards and for providing adequate designs and safeguards for their hardware, software and systems which minimize risk and avoid situations in which a malfunction or failure of Product could cause loss of human life, bodily injury or damage to property, including data loss or corruption. Before customers use the Product, create designs including the Product, or incorporate the Product into their own applications, customers must also refer to and comply with (a) the latest versions of all relevant TOSHIBA information, including without limitation, this document, the specifications, the data sheets and application notes for Product and the precautions and conditions set forth in the "TOSHIBA Semiconductor Reliability Handbook" and (b) the instructions for the application with which the Product will be used with or for. Customers are solely responsible for all aspects of their own product design or applications, including but not limited to (a) determining the appropriateness of the use of this Product in such design or applications; (b) evaluating and determining the applicability of any information contained in this document, or in charts, diagrams, programs, algorithms, sample application circuits, or any other referenced documents; and (c) validating all operating parameters for such designs and applications. **TOSHIBA ASSUMES NO LIABILITY FOR CUSTOMERS' PRODUCT DESIGN OR APPLICATIONS.**
- Product is intended for use in general electronics applications (e.g., computers, personal equipment, office equipment, measuring equipment, industrial robots and home electronics appliances) or for specific applications as expressly stated in this document. Product is neither intended nor warranted for use in equipment or systems that require extraordinarily high levels of quality and/or reliability and/or a malfunction or failure of which may cause loss of human life, bodily injury, serious property damage or serious public impact ("Unintended Use"). Unintended Use includes, without limitation, equipment used in nuclear facilities, equipment used in the aerospace industry, medical equipment, equipment used for automobiles, trains, ships and other transportation, traffic signaling equipment, equipment used to control combustions or explosions, safety devices, elevators and escalators, devices related to electric power, and equipment used in finance-related fields. Do not use Product for Unintended Use unless specifically permitted in this document.
- Do not disassemble, analyze, reverse-engineer, alter, modify, translate or copy Product, whether in whole or in part.
- Product shall not be used for or incorporated into any products or systems whose manufacture, use, or sale is prohibited under any applicable laws or regulations.
- The information contained herein is presented only as guidance for Product use. No responsibility is assumed by TOSHIBA for any infringement of patents or any other intellectual property rights of third parties that may result from the use of Product. No license to any intellectual property right is granted by this document, whether express or implied, by estoppel or otherwise.
- **ABSENT A WRITTEN SIGNED AGREEMENT, EXCEPT AS PROVIDED IN THE RELEVANT TERMS AND CONDITIONS OF SALE FOR PRODUCT, AND TO THE MAXIMUM EXTENT ALLOWABLE BY LAW, TOSHIBA (1) ASSUMES NO LIABILITY WHATSOEVER, INCLUDING WITHOUT LIMITATION, INDIRECT, CONSEQUENTIAL, SPECIAL, OR INCIDENTAL DAMAGES OR LOSS, INCLUDING WITHOUT LIMITATION, LOSS OF PROFITS, LOSS OF OPPORTUNITIES, BUSINESS INTERRUPTION AND LOSS OF DATA, AND (2) DISCLAIMS ANY AND ALL EXPRESS OR IMPLIED WARRANTIES AND CONDITIONS RELATED TO SALE, USE OF PRODUCT, OR INFORMATION, INCLUDING WARRANTIES OR CONDITIONS OF MERCHANTABILITY, FITNESS FOR A PARTICULAR PURPOSE, ACCURACY OF INFORMATION, OR NONINFRINGEMENT.**
- Do not use or otherwise make available Product or related software or technology for any military purposes, including without limitation, for the design, development, use, stockpiling or manufacturing of nuclear, chemical, or biological weapons or missile technology products (mass destruction weapons). Product and related software and technology may be controlled under the Japanese Foreign Exchange and Foreign Trade Law and the U.S. Export Administration Regulations. Export and re-export of Product or related software or technology are strictly prohibited except in compliance with all applicable export laws and regulations.
- Please contact your TOSHIBA sales representative for details as to environmental matters such as the RoHS compatibility of Product. Please use Product in compliance with all applicable laws and regulations that regulate the inclusion or use of controlled substances, including without limitation, the EU RoHS Directive. TOSHIBA assumes no liability for damages or losses occurring as a result of noncompliance with applicable laws and regulations.