

## Wireless Charging Transmitter Coil/Shield

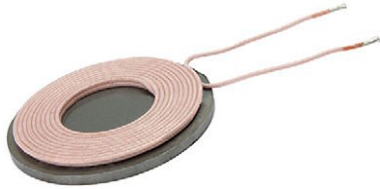

### FEATURES

- Wireless charging transmitter coil
- High permeability shielding for wireless charging
- High saturation powdered iron - not affected by permanent locating magnets
- Durable construction
- AEC-Q200 qualified
- Material categorization: for definitions of compliance please see [www.vishay.com/doc?99912](http://www.vishay.com/doc?99912)

**RoHS**  
COMPLIANT

### SHIELD MATERIAL CHARACTERISTICS

- Permeability: ~ 24
- Resistivity: > 10 M $\Omega$  at 100 V
- Core loss: 4000 mW/cc at 500 gauss, 250 kHz
- Magnetic saturation: 50 % at 4000 gauss (~ 350 O<sub>e</sub>)

STANDARD ELECTRICAL SPECIFICATIONS with Test Coil						
L <sub>0</sub> INDUCTANCE +5 % / -10 % AT 200 kHz, 0.25 V, 0 A ( $\mu$ H)	DCR $\pm$ 10 % AT 25 °C (m $\Omega$ )	Q AT 200 kHz (typ.)	SELF RESONANT FREQUENCY (MHz)	HEAT RATING CURRENT DC TYP. (3) (A)	SATURATION CURRENT DC TYP. (4) (A)	EFFICIENCY (6) (%)
24	71	200	7	6	20	> 70

### Notes

- (1) All test data is referenced to 25 °C ambient.
- (2) Operating Temperature Range -55 °C to +105 °C.
- (3) DC current (A) that will cause an approximate  $\Delta$ T of 40 °C.
- (4) DC current (A) that will cause L<sub>0</sub> to drop approximately 20 %.
- (5) The part temperature (ambient + temp rise) should not exceed 105 °C under worst case operating conditions. Circuit design, component placement, PWB trace size and thickness, airflow and other cooling provisions all affect the part temperature. Part temperature should be verified in the end application.
- (6) When tested using BQ Tesla 500210 Transmitter Chipset, BQ51013 Receiver Chipset and IWAS-4832FF-50 as receiver coil with 2.7 mm spacing. Testing performed per WPC guidelines.

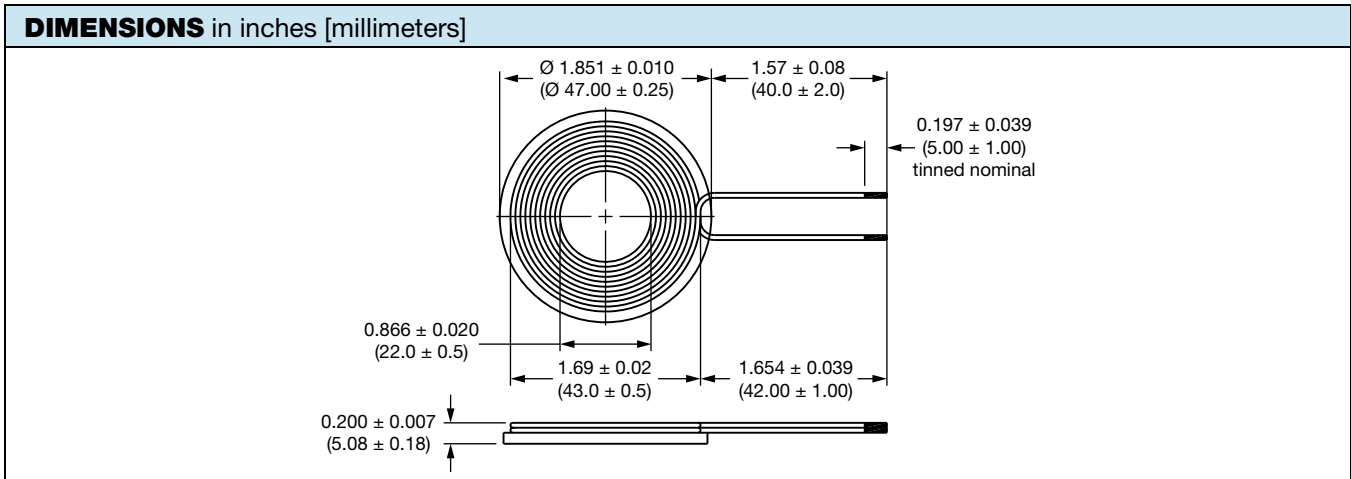

DESCRIPTION			
IWTX-47R0BE-11	10 %	EB	e3
MODEL	INDUCTANCE TOLERANCE	PACKAGE CODE	JEDEC® LEAD (Pb)-FREE STANDARD

GLOBAL PART NUMBER																	
I	W	T	X	4	7	R	0	B	E	E	B	2	4	0	K	1	1
MODEL				SHIELD SIZE			SHIELD THICKNESS		LEAD (Pb)-FREE	PACKAGE	INDUCTANCE VALUE			TOL.	MATERIAL	LEAD CONFIG.	



## **Disclaimer**

ALL PRODUCT, PRODUCT SPECIFICATIONS AND DATA ARE SUBJECT TO CHANGE WITHOUT NOTICE TO IMPROVE RELIABILITY, FUNCTION OR DESIGN OR OTHERWISE.

Vishay Intertechnology, Inc., its affiliates, agents, and employees, and all persons acting on its or their behalf (collectively, "Vishay"), disclaim any and all liability for any errors, inaccuracies or incompleteness contained in any datasheet or in any other disclosure relating to any product.

Vishay makes no warranty, representation or guarantee regarding the suitability of the products for any particular purpose or the continuing production of any product. To the maximum extent permitted by applicable law, Vishay disclaims (i) any and all liability arising out of the application or use of any product, (ii) any and all liability, including without limitation special, consequential or incidental damages, and (iii) any and all implied warranties, including warranties of fitness for particular purpose, non-infringement and merchantability.

Statements regarding the suitability of products for certain types of applications are based on Vishay's knowledge of typical requirements that are often placed on Vishay products in generic applications. Such statements are not binding statements about the suitability of products for a particular application. It is the customer's responsibility to validate that a particular product with the properties described in the product specification is suitable for use in a particular application. Parameters provided in datasheets and / or specifications may vary in different applications and performance may vary over time. All operating parameters, including typical parameters, must be validated for each customer application by the customer's technical experts. Product specifications do not expand or otherwise modify Vishay's terms and conditions of purchase, including but not limited to the warranty expressed therein.

Except as expressly indicated in writing, Vishay products are not designed for use in medical, life-saving, or life-sustaining applications or for any other application in which the failure of the Vishay product could result in personal injury or death. Customers using or selling Vishay products not expressly indicated for use in such applications do so at their own risk. Please contact authorized Vishay personnel to obtain written terms and conditions regarding products designed for such applications.

No license, express or implied, by estoppel or otherwise, to any intellectual property rights is granted by this document or by any conduct of Vishay. Product names and markings noted herein may be trademarks of their respective owners.