

Ultra Low Power DAC with Headphone Driver for Portable Audio Applications

DESCRIPTION

The WM8912 is a high performance ultra-low power stereo DAC optimised for portable audio applications.

The device features stereo ground-referenced headphone amplifiers using the Wolfson 'Class-W' amplifier techniques - incorporating an innovative dual-mode charge pump architecture - to optimise efficiency and power consumption during playback. The ground-referenced outputs eliminate headphone coupling capacitors. The outputs include common mode feedback paths to reject ground noise.

Control sequences for audio path setup can be pre-loaded and executed by an integrated control write sequencer to reduce software driver development and minimise pops and clicks via Wolfson's SilentSwitch™ technology.

A dynamic range controller provides compression and level control to support a wide range of portable recording applications. Anti-clip and quick release features offer good performance in the presence of loud impulsive noises. ReTune™ Mobile 5-band parametric equaliser with fully programmable coefficients is integrated for optimization of speaker characteristics.

Common audio sampling frequencies are supported from a wide range of external clocks, either directly or generated using the integrated FLL.

The WM8912 can operate directly from a single 1.8V switched supply. For optimal power consumption, the digital core can be operated from a 1.0V supply.

FEATURES

- 3.8mW quiescent power consumption for DAC to headphone playback
- DAC SNR 96dB typical, THD -86dB typical
- Class W ground-referenced headphone driver
 - 28mW per channel into 30Ω at <1% THD
 - 32mW per channel into 15Ω at <1% THD
- Dynamic range controller
- ReTune™ Mobile parametric equalizer
- Integrated control write sequencer for pop minimised start-up and shutdown
- Single register write for default start-up and shutdown sequences
- On-chip FLL provides all necessary clocks
- DAC supports standard sample rates from 8kHz to 96kHz
- 32-pin QFN package (4x4mm, 0.4mm pitch)

APPLICATIONS

- Portable multimedia players
- Multimedia handsets
- Handheld gaming

BLOCK DIAGRAM

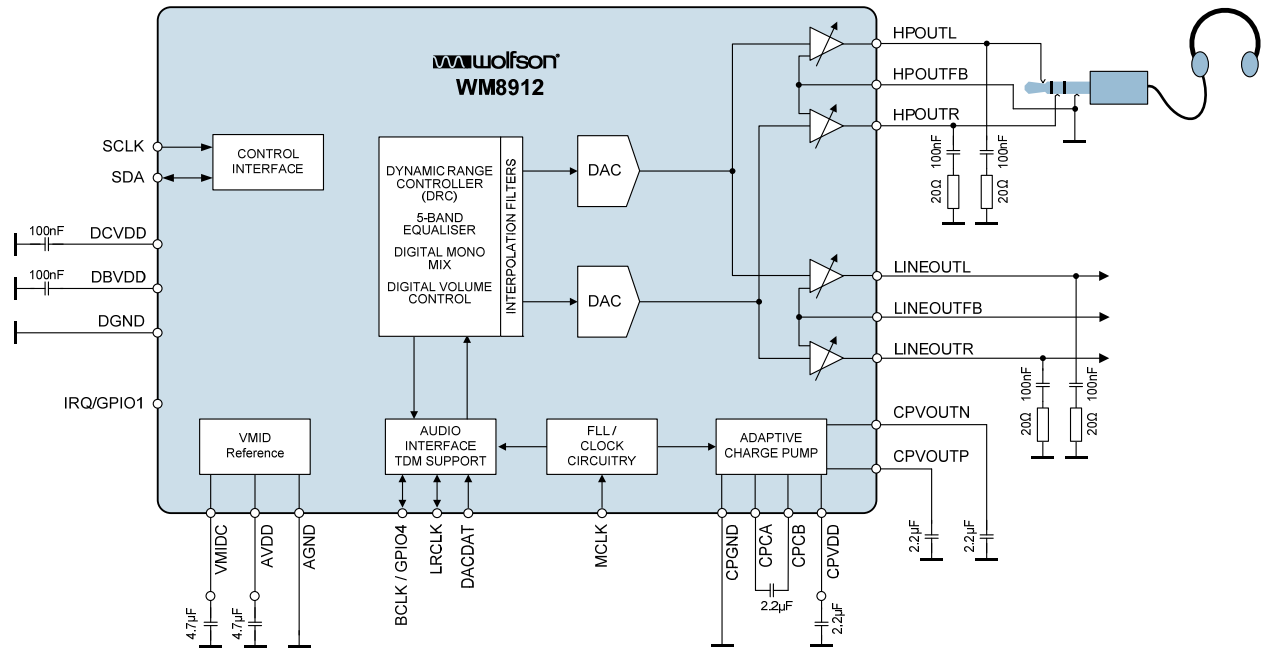

TABLE OF CONTENTS

DESCRIPTION	1
FEATURES	1
APPLICATIONS	1
BLOCK DIAGRAM	2
TABLE OF CONTENTS	3
PIN CONFIGURATION	6
ORDERING INFORMATION	6
PIN DESCRIPTION	7
ABSOLUTE MAXIMUM RATINGS	8
RECOMMENDED OPERATING CONDITIONS	8
ELECTRICAL CHARACTERISTICS	9
TERMINOLOGY	9
COMMON TEST CONDITIONS	9
OUTPUT SIGNAL PATH	10
CHARGE PUMP	11
FLL	11
OTHER PARAMETERS	11
POWER CONSUMPTION	12
COMMON TEST CONDITIONS	12
POWER CONSUMPTION MEASUREMENTS.....	13
SIGNAL TIMING REQUIREMENTS	14
COMMON TEST CONDITIONS	14
MASTER CLOCK	14
AUDIO INTERFACE TIMING	15
MASTER MODE	15
SLAVE MODE.....	16
CONTROL INTERFACE TIMING	17
DIGITAL FILTER CHARACTERISTICS	18
DAC FILTER RESPONSES	19
DE-EMPHASIS FILTER RESPONSES	20
DEVICE DESCRIPTION	21
INTRODUCTION	21
DYNAMIC RANGE CONTROL (DRC).....	22
COMPRESSION/LIMITING CAPABILITIES	22
GAIN LIMITS.....	24
DYNAMIC CHARACTERISTICS	24
ANTI-CLIP CONTROL	25
QUICK RELEASE CONTROL	26
GAIN SMOOTHING	26
INITIALISATION	27
RETUNE™ MOBILE PARAMETRIC EQUALIZER (EQ).....	28
DEFAULT MODE (5-BAND PARAMETRIC EQ)	28
RETUNE™ MOBILE MODE.....	29
EQ FILTER CHARACTERISTICS	29
DIGITAL MIXING	31
DAC INTERFACE ROUTING AND CONTROL	31
DAC INTERFACE VOLUME BOOST	31

DIGITAL-TO-ANALOGUE CONVERTER (DAC)	32
DAC DIGITAL VOLUME CONTROL.....	32
DAC SOFT MUTE AND SOFT UN-MUTE.....	34
DAC MONO MIX.....	35
DAC DE-EMPHASIS.....	35
DAC SLOPING STOPBAND FILTER.....	36
DAC OVERSAMPLING RATIO (OSR).....	36
OUTPUT SIGNAL PATH	37
OUTPUT SIGNAL PATHS ENABLE.....	38
HEADPHONE / LINE OUTPUT SIGNAL PATHS ENABLE.....	38
OUTPUT VOLUME CONTROL.....	41
ANALOGUE OUTPUTS	44
HEADPHONE OUTPUTS – HPOUTL AND HPOUTR.....	44
LINE OUTPUTS – LINEOUTL AND LINEOUTR.....	44
EXTERNAL COMPONENTS FOR GROUND REFERENCED OUTPUTS.....	45
REFERENCE VOLTAGES AND MASTER BIAS	46
CHARGE PUMP	46
DC SERVO	48
DC SERVO ENABLE AND START-UP.....	48
DC SERVO ACTIVE MODES.....	51
DC SERVO READBACK.....	53
DIGITAL AUDIO INTERFACE	53
MASTER AND SLAVE MODE OPERATION.....	53
OPERATION WITH TDM.....	54
BCLK FREQUENCY.....	55
AUDIO DATA FORMATS (NORMAL MODE).....	55
AUDIO DATA FORMATS (TDM MODE).....	57
DIGITAL AUDIO INTERFACE CONTROL	59
AUDIO INTERFACE OUTPUT TRI-STATE.....	59
BCLK AND LRCLK CONTROL.....	60
COMPANDING.....	61
DIGITAL PULL-UP AND PULL-DOWN.....	63
CLOCKING AND SAMPLE RATES	64
SYSCLK CONTROL.....	65
CONTROL INTERFACE CLOCKING.....	66
CLOCKING CONFIGURATION.....	66
DAC CLOCK CONTROL.....	67
OPCLK CONTROL.....	67
TOCLK CONTROL.....	68
DAC OPERATION AT 88.2K / 96K.....	69
FREQUENCY LOCKED LOOP (FLL)	70
FREE-RUNNING FLL CLOCK.....	73
EXAMPLE FLL CALCULATION.....	74
GPIO OUTPUTS FROM FLL.....	75
EXAMPLE FLL SETTINGS.....	75
GENERAL PURPOSE INPUT/OUTPUT (GPIO)	76
IRQ/GPIO1.....	76
BCLK/GPIO4.....	77
INTERRUPTS	78
CONTROL INTERFACE	80
CONTROL WRITE SEQUENCER	83
INITIATING A SEQUENCE.....	83
PROGRAMMING A SEQUENCE.....	84
DEFAULT SEQUENCES.....	86

START-UP SEQUENCE	87
SHUTDOWN SEQUENCE	88
POWER-ON RESET	90
QUICK START-UP AND SHUTDOWN	91
QUICK START-UP (DEFAULT SEQUENCE)	91
FAST START-UP FROM STANDBY	92
QUICK SHUTDOWN (DEFAULT SEQUENCE)	93
SOFTWARE RESET AND CHIP ID	93
REGISTER MAP	94
REGISTER BITS BY ADDRESS	97
APPLICATIONS INFORMATION	126
RECOMMENDED EXTERNAL COMPONENTS	126
PACKAGE DIMENSIONS	127
IMPORTANT NOTICE	128
ADDRESS	128
REVISION HISTORY	129

PIN CONFIGURATION

The WM8912 is supplied in a 32-pin QFN package.

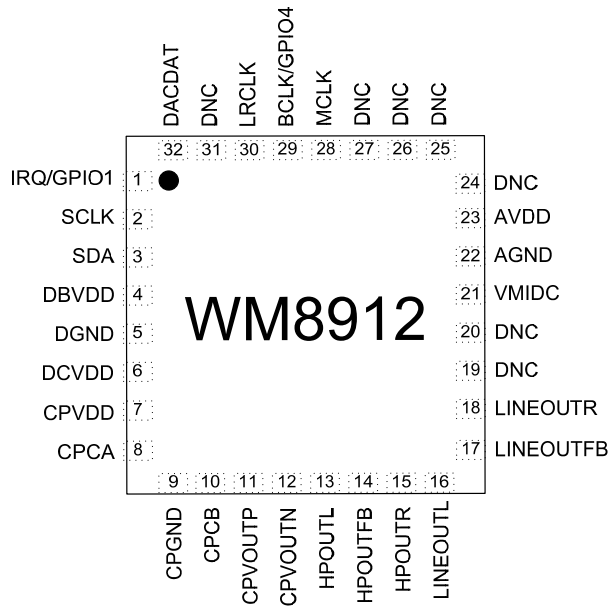

ORDERING INFORMATION

DEVICE	TEMPERATURE RANGE	PACKAGE	MOISTURE SENSITIVITY LEVEL	PEAK SOLDERING TEMPERATURE
WM8912CGEFL/V	-40°C to +85°C	32-lead QFN (4x4x0.4mm, lead-free)	MSL3	260°C
WM8912CGEFL/RV	-40°C to +85°C	32-lead QFN (4x4x0.4mm, lead-free, tape and reel)	MSL3	260°C

Note:

Reel quantity = 3,500

PIN DESCRIPTION

NAME	QFN-32	TYPE	DESCRIPTION
IRQ/GPIO1	1	Digital Input / Output	GPIO1 / Interrupt
SCLK	2	Digital Input	Control interface clock input
SDA	3	Digital Input / Output	Control interface data input / output
DBVDD	4	Supply	Digital buffer supply (powers audio interface and control interface)
DGND	5	Supply	Digital ground (return path for DCVDD and DBVDD)
DCVDD	6	Supply	Digital core supply
CPVDD	7	Supply	Charge pump power supply
CPCA	8	Analogue Input	Charge pump flyback capacitor pin
CPGND	9	Supply	Charge pump ground
CPCB	10	Analogue Input	Charge pump flyback capacitor pin
CPVOUTP	11	Analogue Output	Charge pump positive supply decoupling (powers HPOUTL/R, LINEOUTL/R)
CPVOUTN	12	Analogue Output	Charge pump negative supply decoupling (powers HPOUTL/R, LINEOUTL/R)
HPOUTL	13	Analogue Output	Left headphone output (line or headphone output)
HPOUTFB	14	Analogue Output	Headphone output ground loop noise rejection feedback
HPOUTR	15	Analogue Output	Right headphone output (line or headphone output)
LINEOUTL	16	Analogue Output	Left line output 1 (line output)
LINEOUTFB	17	Analogue Output	Line output ground loop noise rejection feedback
LINEOUTR	18	Analogue Output	Right line output 1 (line output)
DNC	19	n/a	Do Not Connect
DNC	20	n/a	Do Not Connect
VMIDC	21	Analogue Output	Midrail voltage decoupling capacitor
AGND	22	Supply	Analogue power return
AVDD	23	Supply	Analogue power supply
DNC	24	n/a	Do Not Connect
DNC	25	n/a	Do Not Connect
DNC	26	n/a	Do Not Connect
DNC	27	n/a	Do Not Connect
MCLK	28	Digital Input	Master clock for DAC
BCLK/GPIO4	29	Digital Input / Output	Audio interface bit clock / GPIO4
LRCLK	30	Digital Input / Output	Audio interface left / right clock
DNC	31	n/a	Do Not Connect
DACDAT	32	Digital Input	DAC digital audio data
GND_PADDLE	33		Die Paddle

Note:

It is recommended that the QFN ground paddle is connected to analogue ground on the application PCB.

ABSOLUTE MAXIMUM RATINGS

Absolute Maximum Ratings are stress ratings only. Permanent damage to the device may be caused by continuously operating at or beyond these limits. Device functional operating limits and guaranteed performance specifications are given under Electrical Characteristics at the test conditions specified.



ESD Sensitive Device. This device is manufactured on a CMOS process. It is therefore generically susceptible to damage from excessive static voltages. Proper ESD precautions must be taken during handling and storage of this device.

Wolfson tests its package types according to IPC/JEDEC J-STD-020 for Moisture Sensitivity to determine acceptable storage conditions prior to surface mount assembly. These levels are:

MSL1 = unlimited floor life at <30°C / 85% Relative Humidity. Not normally stored in moisture barrier bag.

MSL2 = out of bag storage for 1 year at <30°C / 60% Relative Humidity. Supplied in moisture barrier bag.

MSL3 = out of bag storage for 168 hours at <30°C / 60% Relative Humidity. Supplied in moisture barrier bag.

The Moisture Sensitivity Level for each package type is specified in Ordering Information.

CONDITION	MIN	MAX
AVDD, DCVDD	-0.3V	+2.5V
DBVDD,	-0.3V	+4.5V
CPVDD	-0.3V	+2.2V
HPOUTL, HPOUTR, LINEOUTL, LINEOUTR	(CPVDD + 0.3V) * -1	CPVDD + 0.3V
Voltage range digital inputs	DGND -0.3V	DBVDD +0.3V
Voltage range analogue inputs	AGND -0.3V	AVDD +0.3V
Temperature range, T _A	-40°C	+85°C
Storage temperature after soldering	-65°C	+150°C

Notes:

1. Analogue and digital grounds must always be within 0.3V of each other.
2. All digital and analogue supplies are completely independent from each other; there is no restriction on power supply sequencing.
3. HPOUTL, HPOUTR, LINEOUTL, LINEOUTR are outputs, and should not normally become connected to DC levels. However, if the limits above are exceeded, then damage to the WM8912 may occur.

RECOMMENDED OPERATING CONDITIONS

PARAMETER	SYMBOL	MIN	TYP	MAX	UNIT
Digital supply range (Core)	DCVDD	0.95	1.0	1.98	V
Digital supply range (Buffer)	DBVDD	1.42	1.8	3.6	V
Analogue supplies range	AVDD	1.71	1.8	2.0	V
Charge pump supply range	CPVDD	1.71	1.8	2.0	V
Ground	DGND, AGND, CPGND		0		V
Operating Temperature (ambient)	T _A	-40	+25	+85	°C

ELECTRICAL CHARACTERISTICS

TERMINOLOGY

1. Signal-to-Noise Ratio (dB) – SNR is the difference in level between a full scale output signal and the device output noise with no signal applied, measured over a bandwidth of 20Hz to 20kHz. This ratio is also called idle channel noise. (No Auto-zero or Automute function is employed).
2. Total Harmonic Distortion (dB) – THD is the difference in level between a 1kHz full scale sinewave output signal and the first seven harmonics of the output signal. The amplitude of the fundamental frequency of the output signal is compared to the RMS value of the next seven harmonics and expressed as a ratio.
3. Total Harmonic Distortion + Noise (dB) – THD+N is the difference in level between a 1kHz full scale sine wave output signal and all noise and distortion products in the audio band. The amplitude of the fundamental reference frequency of the output signal is compared to the RMS value of all other noise and distortion products and expressed as a ratio.
4. Channel Separation (dB) – is a measure of the coupling between left and right channels. A full scale signal is applied to the left channel only, the right channel amplitude is measured. Then a full scale signal is applied to the right channel only and the left channel amplitude is measured. The worst case channel separation is quoted as a ratio.
5. Channel Level Matching (dB) – measures the difference in gain between the left and the right channels.
6. Power Supply Rejection Ratio (dB) – PSRR is a measure of ripple attenuation between the power supply pin and an output path. With the signal path idle, a small signal sine wave is summed onto the power supply rail, The amplitude of the sine wave is measured at the output port and expressed as a ratio.
7. All performance measurements carried out with 20kHz AES17 low pass filter for distortion measurements, and an A-weighted filter for noise measurement. Failure to use such a filter will result in higher THD and lower SNR and Dynamic Range readings than are found in the Electrical Characteristics. The low pass filter removes out of band noise; although it is not audible it may affect dynamic specification values.

COMMON TEST CONDITIONS

Unless otherwise stated, the following test conditions apply throughout the following sections:

- DCVDD = 1.0V
- DBVDD = 1.8V
- AVDD = CPVDD = 1.8V
- Ambient temperature = +25°C
- Audio signal: 1kHz sine wave, sampled at 48kHz with 24-bit data resolution
- SYSCLK_SRC = 0 (system clock comes direct from MCLK, not from FLL).

Additional, specific test conditions are given within the relevant sections below.

OUTPUT SIGNAL PATH

Stereo Playback to Headphones - DAC input to HPOUTL+HPOUTR pins with 15Ω load						
Test conditions: HPOUTL_VOL = HPOUTR_VOL = 111001b (0dB)						
PARAMETER	SYMBOL	TEST CONDITIONS	MIN	TYP	MAX	UNIT
Output Power (per Channel)	P _o	1% THD R _{Load} = 30Ω		28 0.92 -0.76		mW Vrms dBV
		1% THD R _{Load} = 15Ω		32 0.69 -3.19		mW Vrms dBV
DC Offset		DC servo enabled, calibration complete.	-1.5		+1.5	mV
Signal to Noise Ratio	SNR	A-weighted	90	96		dB
Total Harmonic Distortion + Noise	THD+N	R _L =30Ω; P _o =2mW		-91		dB
		R _L =30Ω; P _o =20mW		-84		
		R _L =15Ω; P _o =2mW		-87	-80	
		R _L =15Ω; P _o =20mW		-85		
Channel Separation		1kHz signal, 0dBFS		100		dB
		10kHz signal, 0dBFS		90		
Channel Level Matching		1kHz signal, 0dBFS		+/-1		dB
Power Supply Rejection Ratio	PSRR	217Hz, 100mVpk-pk		75		dB
		1kHz, 100mV pk-pk		70		

Stereo Playback to Line-out - DAC input to LINEOUTL+LINEOUTR pins with 10kΩ / 50pF load						
Test conditions: LINEOUTL_VOL = LINEOUTR_VOL = 111001b (0dB)						
PARAMETER	SYMBOL	TEST CONDITIONS	MIN	TYP	MAX	UNIT
Full Scale Output Signal Level		DAC 0dBFS output at 0dB volume		1.0 0 2.83		Vrms dBV Vpk-pk
DC offset		DC servo enabled. Calibration complete.	-1.5		+1.5	mV
Signal to Noise Ratio	SNR	A-weighted	90	96		dB
Total Harmonic Distortion + Noise	THD+N	10kΩ load		-85	-70	dB
Channel Separation		1kHz signal, 0dBFS		100		dB
		10kHz signal, 0dBFS		90		
Channel Level Matching		1kHz signal, 0dBFS		+/-1		dB
Power Supply Rejection Ratio	PSRR	217Hz, 100mVpk-pk		62		dB
		1kHz, 100mV pk-pk		62		

Output PGAs (HP, LINE)						
PARAMETER	TEST CONDITIONS	MIN	TYP	MAX	UNIT	
Minimum PGA gain setting			-57		dB	
Maximum PGA gain setting			6		dB	
PGA Gain Step Size			1		dB	
PGA gain accuracy	+6dB to -40dB	-1.5		+1.5	dB	
PGA gain accuracy	-40dB to -57dB	-1		+1	dB	
Mute attenuation	HPOUTL/R		85		dB	
	LINEOUTL/R		85		dB	

CHARGE PUMP

PARAMETER	TEST CONDITIONS	MIN	TYP	MAX	UNIT
Start-up Time			260		μs
CPCA	Normal mode		CPVDD		V
	Low power mode		CPVDD/2		V
CPCB	Normal mode		-CPVDD		V
	Low power mode		-CPVDD/2		V
External component requirements					
To achieve specified headphone output power and performance					
Flyback Capacitor (between CPCA and CPCB)	at 2V	1	2.2		μF
CPVOUTN Capacitor	at 2V	2	2.2		μF
CPVOUTP Capacitor	at 2V	2	2.2		μF

FLL

PARAMETER	SYMBOL	TEST CONDITIONS	MIN	TYP	MAX	UNIT
Input Frequency	F _{REF}	FLL_CLK_REF_DIV = 00	0.032		13.5	MHz
		FLL_CLK_REF_DIV = 01	0.064		27	MHz
Lock time				2		ms
Free-running mode start-up time		VMID enabled		100		μs
Free-running mode frequency accuracy		Reference supplied initially		+/-10		%
		No reference provided		+/-30		%

OTHER PARAMETERS

VMID Reference					
PARAMETER	TEST CONDITIONS	MIN	TYP	MAX	UNIT
Midrail Reference Voltage (VMID pin)		-3%	AVDD/2	+3%	V
Charge up time (from fully discharged to +5% or -10% of VMID)	External capacitor 4.7μF		890		μs

Digital Inputs / Outputs						
PARAMETER	SYMBOL	TEST CONDITIONS	MIN	TYP	MAX	UNIT
Input HIGH Level	V _{IH}		0.7×DBVDD			V
Input LOW Level	V _{IL}				0.3×DBVDD	V
Output HIGH Level	V _{OH}	I _{OH} = +1mA	0.9×DBVDD			V
Output LOW Level	V _{OL}	I _{OL} = -1mA			0.1×DBVDD	V

POWER CONSUMPTION

The WM8912 power consumption is dependent on many parameters. Most significantly, it depends on supply voltages, sample rates, mode of operation, and output loading.

The power consumption on each supply rail varies approximately with the square of the voltage. Power consumption is greater at fast sample rates than at slower ones. When the digital audio interface is operating in Master mode, the DBVDD current is significantly greater than in Slave mode. (Note also that power savings can be made by using MCLK as the BCLK source in Slave mode.) The output load conditions (impedance, capacitance and inductance) can also impact significantly on the device power consumption.

COMMON TEST CONDITIONS

Unless otherwise stated, the following test conditions apply throughout the following sections:

- Ambient temperature = +25°C
- Audio signal = quiescent (zero amplitude)
- Sample rate = 48kHz
- MCLK = 12.288MHz
- Audio interface mode = Slave (LRCLK_DIR=0, BCLK_DIR=0)
- SYSCLK_SRC = 0 (system clock comes direct from MCLK, not from FLL)

Additional, variant test conditions are quoted within the relevant sections below. Where applicable, power dissipated in the headphone or line loads is included.

POWER CONSUMPTION MEASUREMENTS**Stereo Playback to Headphones** - DAC input to HPOUTL+HPOUTR pins with 30Ω load.**Test conditions:**

VMID_RES = 01 (for normal operation)

CP_DYN_PWR = 1 (Class-W, Charge pump controlled by real-time audio level)

Variant test conditions	AVDD		DCVDD		DBVDD		CPVDD		TOTAL
	V	mA	V	mA	V	mA	V	mA	mW
48kHz sample rate	1.80	1.69	1.00	0.76	1.80	0.00	1.80	0.31	4.38
8kHz sample rate	1.80	1.69	1.00	0.18	1.80	0.00	1.80	0.31	3.80
48kHz, Po = 0.1mW/channel 1kHz sine wave 0dBFS HPOUT_VOL= -25dB DAC_VOL= 0dB	1.80	1.71	1.00	0.77	1.80	0.00	1.80	1.99	7.45
48kHz, Po = 1mW/channel 1kHz sine wave 0dBFS HPOUT_VOL= -15dB DAC_VOL= 0dB	1.80	1.73	1.00	0.77	1.80	0.00	1.80	5.61	13.99
48kHz sample rate, Master mode, FLL enabled, MCLK input frequency = 13MHz	1.80	1.82	1.00	1.05	1.80	0.73	1.80	0.30	6.18
48kHz sample rate, Master mode, FLL enabled, MCLK input frequency = 32.768kHz	1.80	1.83	1.00	0.94	1.80	0.76	1.80	0.29	6.14

Stereo Playback to Line-out - DAC input to LINEOUTL+LINEOUTR or HPOUTL+HPOUTR pins with 10kΩ / 50pF load**Test conditions :**

VMID_RES = 01 (for normal operation)

CP_DYN_PWR = 1 (Class-W, Charge pump controlled by real-time audio level)

Variant test conditions	AVDD		DCVDD		DBVDD		CPVDD		TOTAL
	V	mA	V	mA	V	mA	V	mA	mW
48kHz sample rate	1.8	1.67	1	0.76	1.8	0.00	1.8	0.36	4.43
8kHz sample rate	1.8	1.67	1	0.18	1.8	0.00	1.8	0.36	3.86
48kHz, Po = 0dBFS 1kHz sine wave	1.8	1.78	1	0.77	1.8	0.00	1.8	2.27	8.09

Off**Note:** DC servo calibration is retained in this state as long as DCVDD is supplied. This allows fast, pop suppressed start-up from the off state.

Variant test conditions	AVDD		DCVDD		DBVDD		CPVDD		TOTAL
	V	mA	V	mA	V	mA	V	mA	mW
Off (default settings) No Clocks applied	1.8	0.01	1	0.00	1.8	0.00	1.8	0.01	0.04
Off (default settings) DACDAT, MCLK, BCLK, and LRCLK applied	1.8	0.01	1	0.02	1.8	0.00	1.8	0.01	0.06

SIGNAL TIMING REQUIREMENTS

COMMON TEST CONDITIONS

Unless otherwise stated, the following test conditions apply throughout the following sections:

- Ambient temperature = +25°C
- DCVDD = 1.0V
- DBVDD = AVDD = CPVDD = 1.8V
- DGND = AGND = CPGND = 0V

Additional, specific test conditions are given within the relevant sections below.

MASTER CLOCK

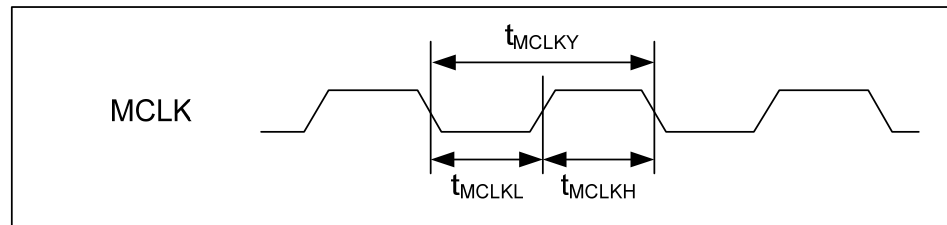

Figure 1 Master Clock Timing

Master Clock Timing						
PARAMETER	SYMBOL	TEST CONDITIONS	MIN	TYP	MAX	UNIT
MCLK cycle time	T_{MCLKY}	MCLK_DIV=1	40			ns
		MCLK_DIV=0	80			ns
MCLK duty cycle	T_{MCLKDS}		60:40		40:60	

AUDIO INTERFACE TIMING

MASTER MODE

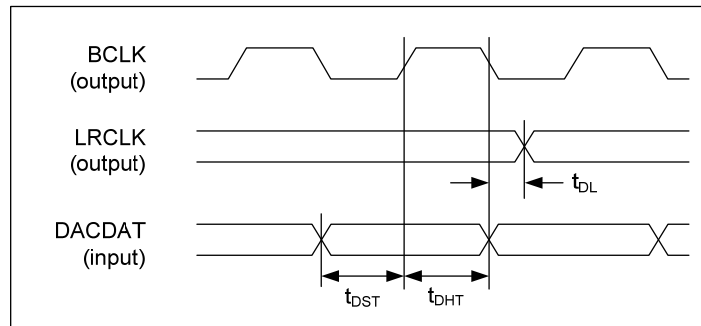

Figure 2 Audio Interface Timing – Master Mode

Test Conditions

DCVDD = 1.0V, AVDD = DBVDD = CPVDD = 1.8V, DGND=AGND=CPGND =0V, $T_A = +25^{\circ}\text{C}$, Master Mode, $f_s=48\text{kHz}$, $MCLK=256f_s$, 24-bit data, unless otherwise stated.

PARAMETER	SYMBOL	MIN	TYP	MAX	UNIT
Audio Interface Timing - Master Mode					
LRCLK propagation delay from BCLK falling edge	t_{DL}			20	ns
DACDAT setup time to BCLK rising edge	t_{DST}	20			ns
DACDAT hold time from BCLK rising edge	t_{DHT}	10			ns

SLAVE MODE

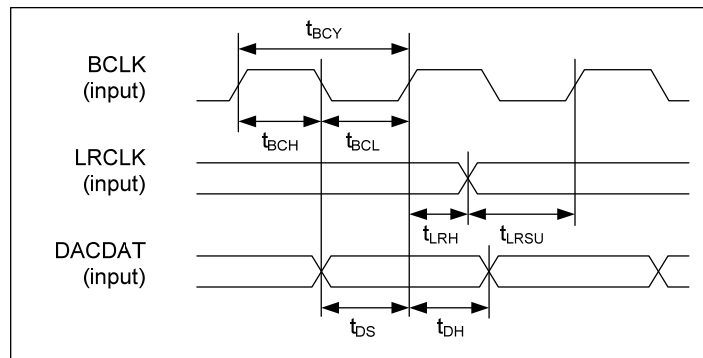

Figure 3 Audio Interface Timing – Slave Mode

Test Conditions

DCVDD = 1.0V, AVDD = DBVDD = CPVDD = 1.8V, DGND=AGND=CPGND =0V, $T_A = +25^\circ\text{C}$, Slave Mode, $f_s=48\text{kHz}$, $MCLK=256f_s$, 24-bit data, unless otherwise stated.

PARAMETER	SYMBOL	MIN	TYP	MAX	UNIT
Audio Interface Timing - Slave Mode					
BCLK cycle time	t_{BCY}	50			ns
BCLK pulse width high	t_{BCH}	20			ns
BCLK pulse width low	t_{BCL}	20			ns
LRCLK set-up time to BCLK rising edge	t_{LRSU}	20			ns
LRCLK hold time from BCLK rising edge	t_{LRH}	10			ns
DACDAT hold time from BCLK rising edge	t_{DH}	10			ns
DACDAT set-up time to BCLK rising edge	t_{DS}	20			ns

Note: BCLK period must always be greater than or equal to MCLK period.

CONTROL INTERFACE TIMING

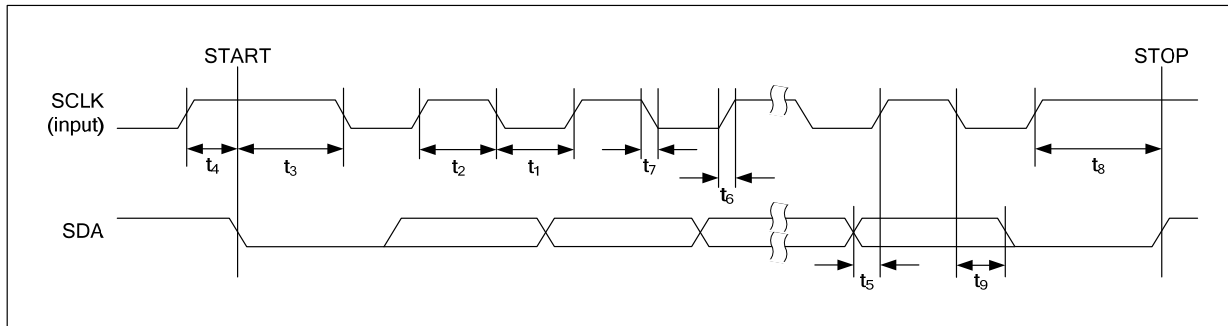

Figure 4 Control Interface Timing

Test Conditions

DCVDD = 1.0V, AVDD = DBVDD = CPVDD = 1.8V, DGND=AGND=CPGND =0V, $T_A=+25^\circ\text{C}$, Slave Mode, $f_s=48\text{kHz}$, MCLK = 256fs, 24-bit data, unless otherwise stated.

PARAMETER	SYMBOL	MIN	TYP	MAX	UNIT
SCLK Frequency				400	kHz
SCLK Low Pulse-Width	t_1	1300			ns
SCLK High Pulse-Width	t_2	600			ns
Hold Time (Start Condition)	t_3	600			ns
Setup Time (Start Condition)	t_4	600			ns
Data Setup Time	t_5	100			ns
SDA, SCLK Rise Time	t_6			300	ns
SDA, SCLK Fall Time	t_7			300	ns
Setup Time (Stop Condition)	t_8	600			ns
Data Hold Time	t_9			900	ns
Pulse width of spikes that will be suppressed	t_{ps}	0		5	ns

DIGITAL FILTER CHARACTERISTICS

PARAMETER	TEST CONDITIONS	MIN	TYP	MAX	UNIT
DAC Normal Filter					
Passband	+/- 0.05dB	0		0.454 fs	
	-6dB		0.5 fs		
Passband Ripple	0.454 fs			+/- 0.03	dB
Stopband		0.546 fs			
Stopband Attenuation	F > 0.546 fs	-50			dB
DAC Sloping Stopband Filter					
Passband	+/- 0.03dB	0		0.25 fs	
	+/- 1dB	0.25 fs		0.454 fs	
	-6dB		0.5 fs		
Passband Ripple	0.25 fs			+/- 0.03	dB
Stopband 1		0.546 fs		0.7 fs	
Stopband 1 Attenuation	f > 0.546 fs	-60			dB
Stopband 2		0.7 fs		1.4 fs	
Stopband 2 Attenuation	f > 0.7 fs	-85			dB
Stopband 3		1.4 fs			
Stopband 3 Attenuation	F > 1.4 fs	-55			dB

DAC FILTERS	
Mode	Group Delay
Normal	16.5 / fs
Sloping Stopband	18 / fs

TERMINOLOGY

1. Stop Band Attenuation (dB) – the degree to which the frequency spectrum is attenuated (outside audio band)
2. Pass-band Ripple – any variation of the frequency response in the pass-band region

DAC FILTER RESPONSES

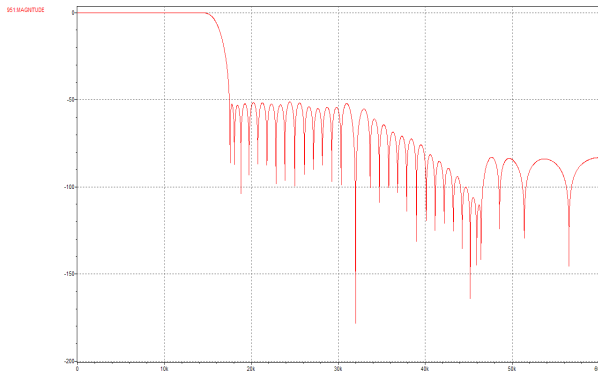

Figure 5 DAC Digital Filter Frequency Response; (Normal Mode); Sample Rate > 24kHz

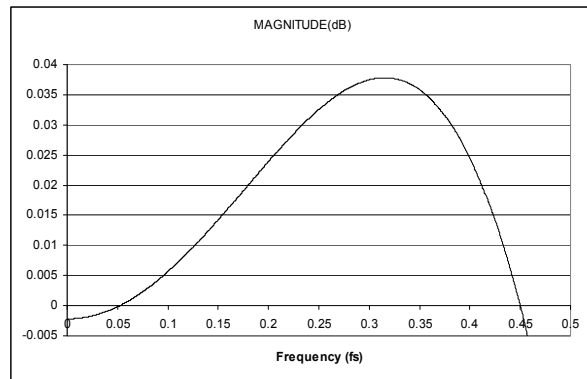

Figure 6 DAC Digital Filter Ripple (Normal Mode)

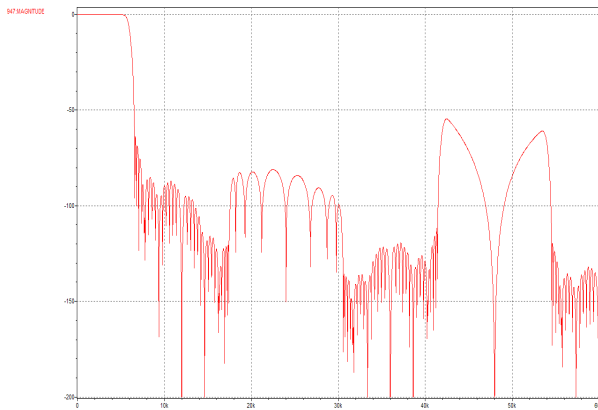

Figure 7 DAC Digital Filter Frequency Response; (Sloping Stopband Mode); Sample Rate <= 24kHz

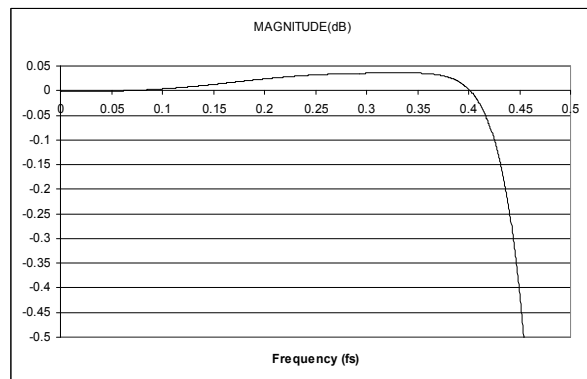

Figure 8 DAC Digital Filter Ripple (Sloping Stopband Mode)

DE-EMPHASIS FILTER RESPONSES

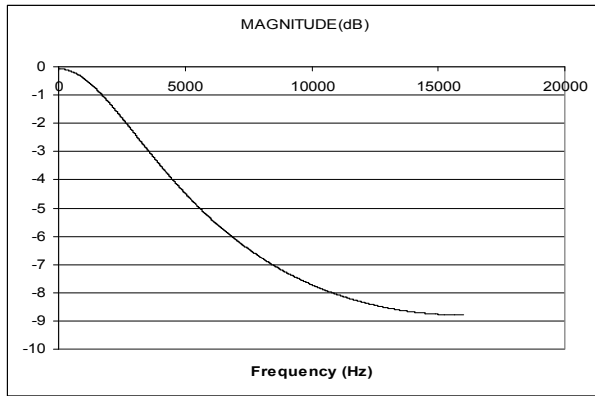

Figure 9 De-Emphasis Digital Filter Response (32kHz)

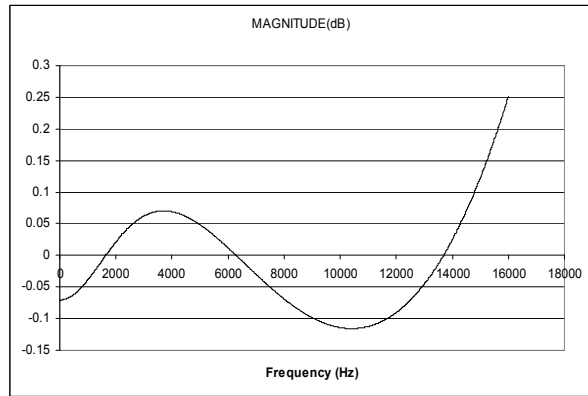

Figure 10 De-Emphasis Error (32kHz)

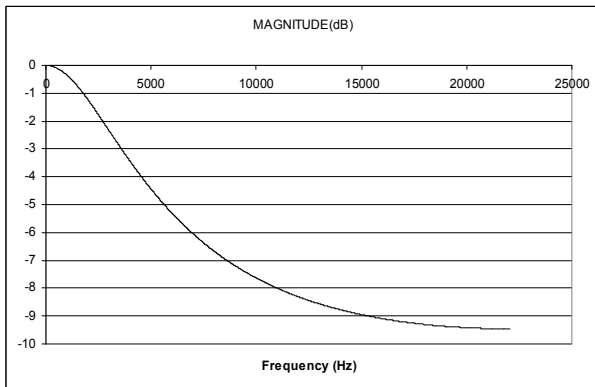

Figure 11 De-Emphasis Digital Filter Response (44.1kHz)

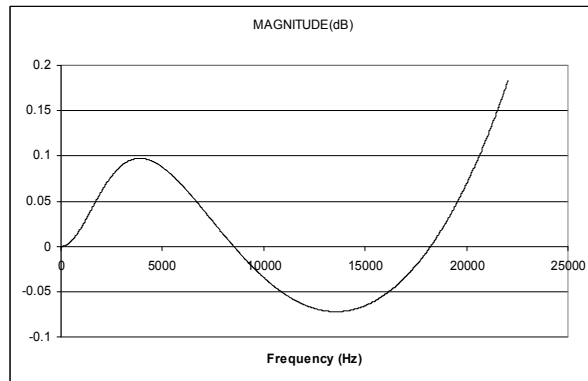

Figure 12 De-Emphasis Error (44.1kHz)

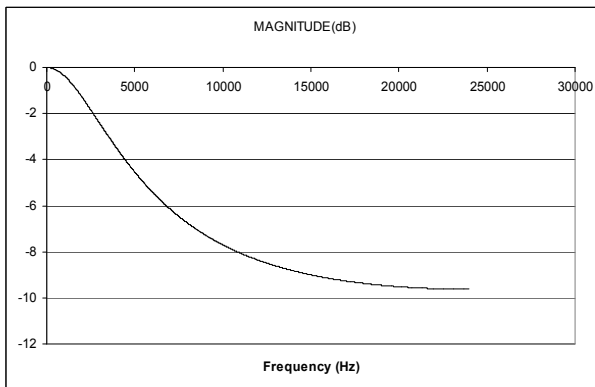

Figure 13 De-Emphasis Digital Filter Response (48kHz)

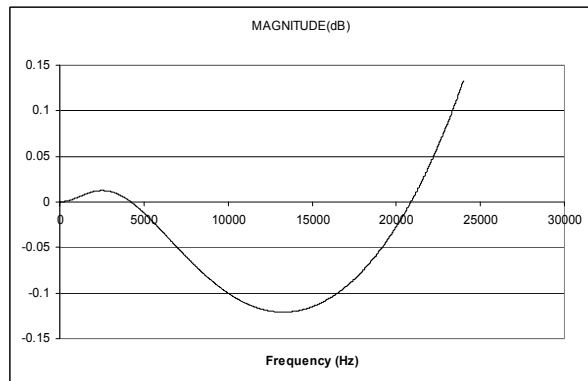

Figure 14 De-Emphasis Error (48kHz)

DEVICE DESCRIPTION

INTRODUCTION

The WM8912 is a high performance ultra-low power stereo DAC optimised for portable audio applications. Powerful digital signal processing (DSP) makes it ideal for small portable devices.

Two stereo pairs of ground-referenced Class-W outputs are provided, suitable for driving a stereo headphone and stereo line load simultaneously. The ground-referenced outputs are powered from an integrated Charge Pump, enabling high quality, power efficient outputs without requirement for DC blocking capacitors. A DC Servo circuit is available for DC offset correction, thereby suppressing pops and further reducing power consumption. Ground loop feedback is provided on the headphone outputs and on the line outputs, providing rejection of noise on the ground connections. All outputs use Wolfson SilentSwitch™ technology for pop and click suppression.

The stereo DACs are of hi-fi quality, using a 24-bit low-order oversampling architecture to deliver optimum performance. A flexible clocking arrangement supports all commonly used DAC sample rates, either directly from an external MCLK or with the use of the integrated Frequency Locked Loop (FLL) for additional flexibility. DAC soft mute and un-mute is available for pop-free music playback.

The integrated Dynamic Range Controller (DRC) and ReTune™ Mobile 5-band parametric equaliser (EQ) provide further processing capability of the digital audio paths. The DRC provides compression and signal level control to improve the handling of unpredictable signal levels. 'Anti-clip' and 'quick release' algorithms improve intelligibility in the presence of transients and impulsive noises. The EQ provides the capability to tailor the audio path according to the frequency characteristics of an earpiece or loudspeaker, and/or according to user preferences.

The WM8912 has a highly flexible digital audio interface, supporting a number of protocols, including I²S, DSP, MSB-first left/right justified, and can operate in master or slave modes. PCM operation is supported in the DSP mode. A-law and μ -law companding are also supported. Time division multiplexing (TDM) is available to allow multiple devices to stream data simultaneously on the same bus, saving space and power.

The system clock (SYSCLK) provides clocking for the DACs, DSP core, digital audio interface and other circuits. SYSCLK can be derived directly from the MCLK pin or via the integrated FLL, providing flexibility to support a wide range of clocking schemes. Typical portable system MCLK frequencies and commonly used sample rates from 8kHz to 48kHz are all supported. The clocking circuits are configured automatically from the sample rate and from the MCLK / SYSCLK ratio.

The integrated FLL can be used to generate SYSCLK from a wide variety of different reference sources and frequencies. The FLL can accept a wide range of reference frequencies, which may be high frequency (e.g. 13MHz) or low frequency (eg. 32.768kHz). The FLL is tolerant of jitter and may be used to generate a stable SYSCLK from a less stable input signal. The integrated FLL can be used as a free-running oscillator, enabling autonomous clocking of the Headphone Charge Pump and DC Servo if required.

The WM8912 uses a standard 2-wire control interface, providing full software control of all features, together with device register readback. An integrated Control Write Sequencer enables automatic scheduling of control sequences; commonly-used signal configurations may be selected using ready-programmed sequences, including time-optimised control of the WM8912 pop suppression features. It is an ideal partner for a wide range of industry standard microprocessors, controllers and DSPs. Unused circuitry can be disabled under software control, in order to save power; low leakage currents enable extended standby/off time in portable battery-powered applications.

Two GPIO pins may be configured for miscellaneous input/output functions such as button/accessory detect inputs, or for clock, system status, or programmable logic level output for control of additional external circuitry. Interrupt logic, status readback and de-bouncing options are supported within this functionality.

DYNAMIC RANGE CONTROL (DRC)

The dynamic range controller (DRC) is a circuit which can be enabled in the digital DAC playback path. The function of the DRC is to adjust the signal gain in conditions where the input amplitude is unknown or varies over a wide range, e.g. when recording from microphones built into a handheld system. The DRC can apply Compression and Automatic Level Control to the signal path. It incorporates 'anti-clip' and 'quick release' features for handling transients in order to improve intelligibility in the presence of loud impulsive noises.

The DRC is enabled in the digital DAC playback path by setting DRC_ENA and DRC_DAC_PATH, as shown in Table 1. Both bits must be set for DRC operation.

REGISTER ADDRESS	BIT	LABEL	DEFAULT	DESCRIPTION
R40 (28h) DRC Control 0	15	DRC_ENA	0	DRC enable 0 = disabled 1 = enabled
	14	DRC_DAC_PATH	0	DRC path select 0 = Reserved 1 = DAC path

Table 1 DRC Enable

COMPRESSION/LIMITING CAPABILITIES

The DRC supports two different compression regions, separated by a "knee" at input amplitude T. For signals above the knee, the compression slope DRC_HI_COMP applies; for signals below the knee, the compression slope DRC_LO_COMP applies.

The overall DRC compression characteristic in "steady state" (i.e. where the input amplitude is near-constant) is illustrated in Figure 15.

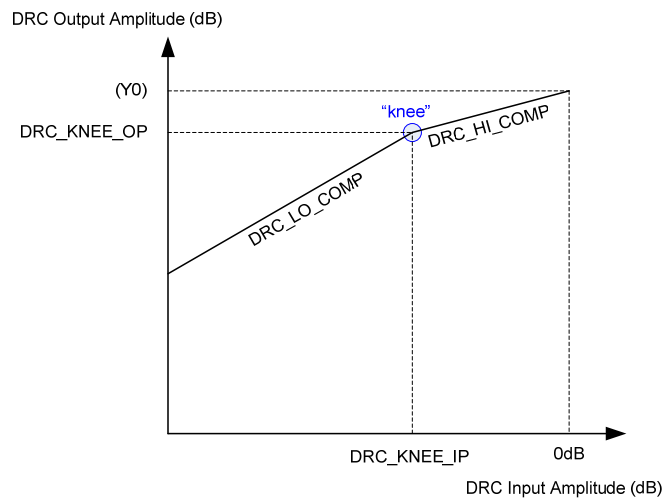

Figure 15 DRC Compression Characteristic

The slope of the DRC response is determined by register fields DRC_HI_COMP and DRC_LO_COMP respectively. A slope of 1 indicates constant gain in this region. A slope less than 1 represents compression (i.e. a change in input amplitude produces only a smaller change in output amplitude). A slope of 0 indicates that the target output amplitude is the same across a range of input amplitudes; this is infinite compression.

The “knee” in Figure 15 is determined by register fields DRC_KNEE_IP and DRC_KNEE_OP.

Parameter Y0, the output level for a 0dB input, is not specified directly, but can be calculated from the other parameters, using the equation.

$$Y0 = DRC_KNEE_OP - (DRC_KNEE_IP * DRC_HI_COMP)$$

The DRC Compression parameters are defined in Table 2.

REGISTER ADDRESS	BIT	LABEL	DEFAULT	DESCRIPTION
R43 (2Bh) DRC Control 3	10:5	DRC_KNEE_IP [5:0]	00_0000	Input signal at the Compressor 'knee'. 000000 = 0dB 000001 = -0.75dB 000010 = -1.5dB ... (-0.75dB steps) 111100 = -45dB 111101 to 111111 = Reserved
	4:0	DRC_KNEE_OP [4:0]	0_0000	Output signal at the Compressor 'knee'. 00000 = 0dB 00001 = -0.75dB 00010 = -1.5dB ... (-0.75dB steps) 11110 = -22.5dB 11111 = Reserved
R42 (2Ah) DRC Control 2	5:3	DRC_HI_COMP [2:0]	000	Compressor slope (upper region) 000 = 1 (no compression) 001 = 1/2 010 = 1/4 011 = 1/8 100 = 1/16 101 = 0 110 to 111 = Reserved
	2:0	DRC_LO_COMP [2:0]	000	Compressor slope (lower region) 000 = 1 (no compression) 001 = 1/2 010 = 1/4 011 = 1/8 100 = 0 101 to 111 = Reserved

Table 2 DRC Compression Control

GAIN LIMITS

The minimum and maximum gain applied by the DRC is set by register fields DRC_MINGAIN and DRC_MAXGAIN. These limits can be used to alter the DRC response from that illustrated in Figure 15. If the range between maximum and minimum gain is reduced, then the extent of the dynamic range control is reduced. The maximum gain prevents quiet signals (or silence) from being excessively amplified.

REGISTER ADDRESS	BIT	LABEL	DEFAULT	DESCRIPTION
R41 (29h) DRC Control 1	3:2	DRC_MINGAIN [1:0]	10	Minimum gain the DRC can use to attenuate audio signals 00 = 0dB (default) 01 = -6dB 10 = -12dB 11 = -18dB
	1:0	DRC_MAXGAIN [1:0]	00	Maximum gain the DRC can use to boost audio signals 00 = 12dB 01 = 18dB (default) 10 = 24dB 11 = 36dB

Table 3 DRC Gain Limits

DYNAMIC CHARACTERISTICS

The dynamic behaviour determines how quickly the DRC responds to changing signal levels. Note that the DRC responds to the average (RMS) signal amplitude over a period of time.

DRC_ATK determines how quickly the DRC gain decreases when the signal amplitude is high. DRC_DCY determines how quickly the DRC gain increases when the signal amplitude is low.

These register fields are described in Table 4. Note that the register defaults are suitable for general purpose microphone use.

REGISTER ADDRESS	BIT	LABEL	DEFAULT	DESCRIPTION
R41 (29h) DRC Control 1	15:12	DRC_ATK [3:0]	0011	Gain attack rate (seconds/6dB) 0000 = Reserved 0001 = 182µs 0010 = 363µs 0011 = 726µs (default) 0100 = 1.45ms 0101 = 2.9ms 0110 = 5.8ms 0111 = 11.6ms 1000 = 23.2ms 1001 = 46.4ms 1010 = 92.8ms 1011-1111 = Reserved

REGISTER ADDRESS	BIT	LABEL	DEFAULT	DESCRIPTION
	11:8	DRC_DCY [3:0]	0010	Gain decay rate (seconds/6dB) 0000 = 186ms 0001 = 372ms 0010 = 743ms (default) 0011 = 1.49s 0100 = 2.97s 0101 = 5.94s 0110 = 11.89s 0111 = 23.78s 1000 = 47.56s 1001-1111 = Reserved

Table 4 DRC Attack and Decay Rates

Note:

For detailed information about DRC attack and decay rates, please see Wolfson application note WAN0247.

ANTI-CLIP CONTROL

The DRC includes an Anti-Clip feature to avoid signal clipping when the input amplitude rises very quickly. This feature uses a feed-forward technique for early detection of a rising signal level. Signal clipping is avoided by dynamically increasing the gain attack rate when required. The Anti-Clip feature is enabled using the DRC_ANTICLIP bit.

Note that the feed-forward processing increases the latency in the input signal path. For low-latency applications (e.g. telephony), it may be desirable to reduce the delay, although this will also reduce the effectiveness of the anti-clip feature. The latency is determined by the DRC_FF_DELAY bit. If necessary, the latency can be minimised by disabling the anti-clip feature altogether.

The DRC Anti-Clip control bits are described in Table 5.

REGISTER ADDRESS	BIT	LABEL	DEFAULT	DESCRIPTION
R40 (28h) DRC Control 0	5	DRC_FF_DELAY	1	Feed-forward delay for anti-clip feature 0 = 5 samples 1 = 9 samples Time delay can be calculated as $5/f_s$ or $9/f_s$, where f_s is the sample rate.
	1	DRC_ANTICLIP	1	Anti-clip enable 0 = disabled 1 = enabled

Table 5 DRC Anti-Clip Control

Note that the Anti-Clip feature operates entirely in the digital domain. It cannot be used to prevent signal clipping in the analogue domain nor in the source signal. Analogue clipping can only be prevented by reducing the analogue signal gain or by adjusting the source signal.

QUICK RELEASE CONTROL

The DRC includes a Quick-Release feature to handle short transient peaks that are not related to the intended source signal. For example, in handheld microphone recording, transient signal peaks sometimes occur due to user handling, key presses or accidental tapping against the microphone. The Quick Release feature ensures that these transients do not cause the intended signal to be masked by the longer time constants of DRC_DCY.

The Quick-Release feature is enabled by setting the DRC_QR bit. When this bit is enabled, the DRC measures the crest factor (peak to RMS ratio) of the input signal. A high crest factor is indicative of a transient peak that may not be related to the intended source signal. If the crest factor exceeds the level set by DRC_QR_THR, then the normal decay rate (DRC_DCY) is ignored and a faster decay rate (DRC_QR_DCY) is used instead.

The DRC Quick-Release control bits are described in Table 6.

REGISTER ADDRESS	BIT	LABEL	DEFAULT	DESCRIPTION
R40 (28h) DRC Control 0	2	DRC_QR	1	Quick release enable 0 = disabled 1 = enabled
R41 (29h) DRC Control 1	7:6	DRC_QR_THR [1:0]	01	Quick release crest factor threshold 00 = 12dB 01 = 18dB (default) 10 = 24dB 11 = 30dB
	5:4	DRC_QR_DCY [1:0]	00	Quick release decay rate (seconds/6dB) 00 = 0.725ms (default) 01 = 1.45ms 10 = 5.8ms 11 = Reserved

Table 6 DRC Quick-Release Control

GAIN SMOOTHING

The DRC includes a gain smoothing filter in order to prevent gain ripples. A programmable level of hysteresis is also used to control the DRC gain. This improves the handling of very low frequency input signals whose period is close to the DRC attack/decay time. DRC Gain Smoothing is enabled by default and it is recommended to use the default register settings.

The extent of the gain smoothing filter may be adjusted or disabled using the control fields described in Table 7.

REGISTER ADDRESS	BIT	LABEL	DEFAULT	DESCRIPTION
R40 (28h) DRC Control 0	12:11	DRC_GS_HYST _LVL [1:0]	00	Gain smoothing hysteresis threshold 00 = Low 01 = Medium (recommended) 10 = High 11 = Reserved
	3	DRC_GS_ENA	1	Gain smoothing enable 0 = disabled 1 = enabled
	0	DRC_GS_HYST	1	Gain smoothing hysteresis enable 0 = disabled 1 = enabled

Table 7 DRC Gain Smoothing

INITIALISATION

When the DRC is initialised, the gain is set to the level determined by the DRC_STARTUP_GAIN register field. The default setting is 0dB, but values from -3dB to +6dB are available, as described in Table 8.

REGISTER ADDRESS	BIT	LABEL	DEFAULT	DESCRIPTION
R40 (28h) DRC Control 0	10:6	DRC_STARTUP_GAIN [4:0]	00110	Initial gain at DRC start-up 00000 = -3dB 00001 = -2.5dB 00010 = -2dB 00011 = -1.5dB 00100 = -1dB 00101 = -0.5dB 00110 = 0dB (default) 00111 = 0.5dB 01000 = 1dB 01001 = 1.5dB 01010 = 2dB 01011 = 2.5dB 01100 = 3dB 01101 = 3.5dB 01110 = 4dB 01111 = 4.5dB 10000 = 5dB 10001 = 5.5dB 10010 = 6dB 10011 to 11111 = Reserved

Table 8 DRC Initialisation

RETUNE™ MOBILE PARAMETRIC EQUALIZER (EQ)

The ReTune™ Mobile Parametric Equaliser is a circuit that can be enabled in the DAC path. The function of the EQ is to adjust the frequency characteristic of the output to compensate for unwanted frequency characteristics in the loudspeaker (or other output transducer). It can also be used to tailor the response according to user preferences, for example to accentuate or attenuate specific frequency bands to emulate different sound profiles or environments such as concert hall, rock etc. The EQ is enabled using the EQ_ENA bit as shown in Table 9.

REGISTER ADDRESS	BIT	LABEL	DEFAULT	DESCRIPTION
R134 (86h) EQ1	0	EQ_ENA	0	EQ enable 0 = EQ disabled 1 = EQ enabled

Table 9 ReTune™ Mobile Parametric EQ Enable

The EQ can be configured to operate in two modes - "Default" mode or "ReTune™ Mobile" mode.

DEFAULT MODE (5-BAND PARAMETRIC EQ)

In default mode, the cut-off / centre frequencies are fixed as per Table 10. The filter bandwidths are also fixed in default mode. The gain of the individual bands (-12dB to +12dB) can be controlled as described in Table 11.

Note that the cut-off / centre frequencies noted in Table 10 are applicable to a DAC Sample Rate of 48kHz. When using other sample rates, these frequencies will be scaled in proportion to the selected sample rate.

EQ BAND	CUT-OFF/CENTRE FREQUENCY
1	100 Hz
2	300 Hz
3	875 Hz
4	2400 Hz
5	6900 Hz

Table 10 EQ Band Cut-off / Centre Frequencies

REGISTER ADDRESS	BIT	LABEL	DEFAULT	DESCRIPTION
R135 (87h) EQ2	4:0	EQ_B1_GAIN [4:0]	01100b (0dB)	EQ Band 1 Gain (see Table 12 for gain range)
R136 (88h) EQ3	4:0	EQ_B2_GAIN [4:0]	01100b (0dB)	EQ Band 2 Gain (see Table 12 for gain range)
R137 (89h) EQ4	4:0	EQ_B3_GAIN [4:0]	01100b (0dB)	EQ Band 3 Gain (see Table 12 for gain range)
R138 (8Ah) EQ5	4:0	EQ_B4_GAIN [4:0]	01100b (0dB)	EQ Band 4 Gain (see Table 12 for gain range)
R139 (8Bh) EQ6	4:0	EQ_B5_GAIN [4:0]	01100b (0dB)	EQ Band 5 Gain (see Table 12 for gain range)

Table 11 EQ Band Gain Control

EQ GAIN SETTING	GAIN (DB)
00000	-12
00001	-11
00010	-10
00011	-9
00100	-8
00101	-7
00110	-6
00111	-5
01000	-4
01001	-3
01010	-2
01011	-1
01100	0
01101	+1
01110	+2
01111	+3
10000	+4
10001	+5
10010	+6
10011	+7
10100	+8
10101	+9
10110	+10
10111	+11
11000	+12
11001 to 11111	Reserved

Table 12 EQ Gain Control

RETUNE™ MOBILE MODE

ReTune™ Mobile mode provides a comprehensive facility for the user to define the cut-off/centre frequencies and filter bandwidth for each EQ band, in addition to the gain controls already described. This enables the EQ to be accurately customised for a specific transducer characteristic or desired sound profile.

The EQ enable and EQ gain controls are the same as defined for the default mode. The additional coefficients used in ReTune™ Mobile mode are held in registers R140 to R157. These coefficients are derived using tools provided in Wolfson's WISCE™ evaluation board control software.

Please contact your local Wolfson representative for more details.

EQ FILTER CHARACTERISTICS

The filter characteristics for each frequency band are shown in Figure 16 to Figure 20. These figures show the frequency response for all available gain settings, using default cut-off/centre frequencies and bandwidth.

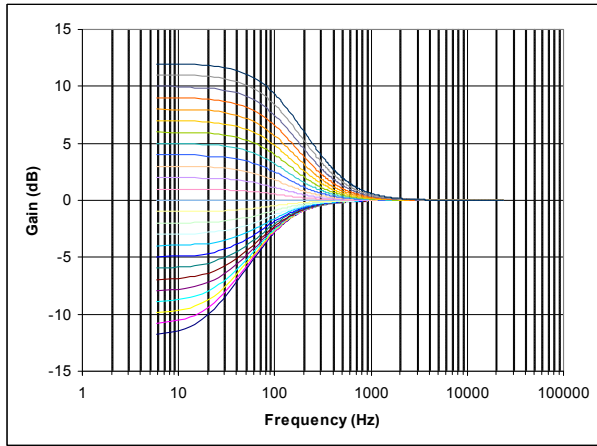

Figure 16 EQ Band 1 – Low Freq Shelf Filter Response

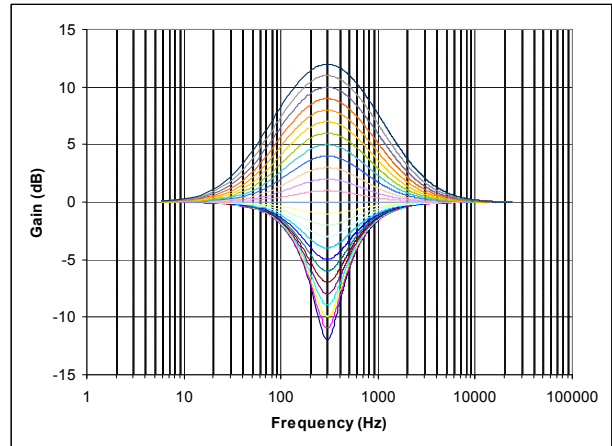

Figure 17 EQ Band 2 – Peak Filter Response

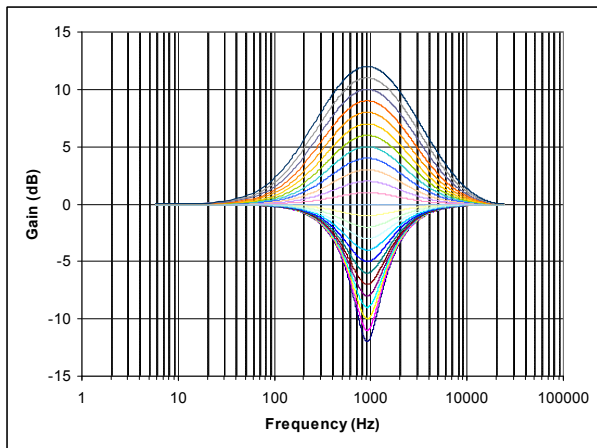

Figure 18 EQ Band 3 – Peak Filter Response

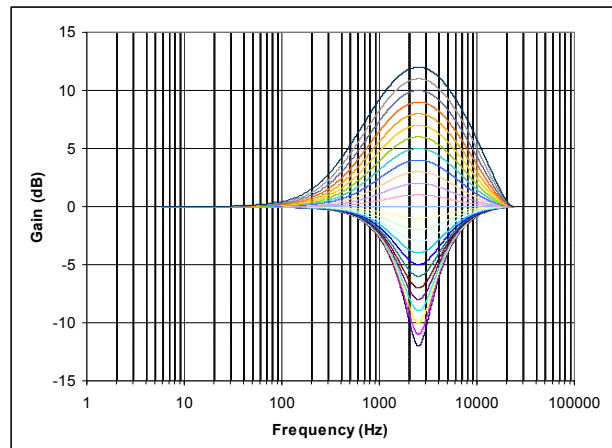

Figure 19 EQ Band 4 – Peak Filter Response

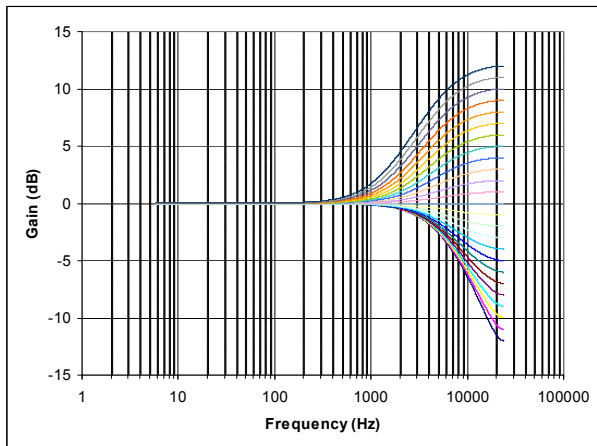

Figure 20 EQ Band 5 – High Freq Shelf Filter Response

DIGITAL MIXING

The digital DAC data can be controlled in various ways to support a range of different usage modes.

Data from either of the digital audio interface channels can be routed to either the left or the right DAC. The DACs can be configured as a mono mix of the two audio channels. See "Digital Audio Interface Control" for more information on the audio interface.

The WM8912 provides a Dynamic Range Control (DRC) feature, which can apply compression and gain adjustment in the digital domain to the DAC signal path. This is effective in controlling signal levels under conditions where input amplitude is unknown or varies over a wide range. See "Dynamic Range Control (DRC)" for further details.

The WM8912 also incorporates the ReTune™ Mobile 5-band parametric equaliser with fully programmable coefficients for optimization of speaker characteristics or for tailoring the response according to user preferences. See "ReTune™ Mobile Parametric Equalizer (EQ)" for further details.

DAC INTERFACE ROUTING AND CONTROL

The input data source for each DAC can be changed under software control using register bits AIFDACL_SRC and AIFDACR_SRC. The polarity of each DAC input may also be modified using register bits DACL_DATINV and DACR_DATINV. These register bits are described in Table 13.

REGISTER ADDRESS	BIT	LABEL	DEFAULT	DESCRIPTION
R24 (18h) Audio Interface 0	12	DACL_DATINV	0	Left DAC Invert 0 = Left DAC output not inverted 1 = Left DAC output inverted
	11	DACR_DATINV	0	Right DAC Invert 0 = Right DAC output not inverted 1 = Right DAC output inverted
	5	AIFDACL_SRC	0	Left DAC Data Source Select 0 = Left DAC outputs left interface data 1 = Left DAC outputs right interface data
	4	AIFDACR_SRC	1	Right DAC Data Source Select 0 = Right DAC outputs left interface data 1 = Right DAC outputs right interface data

Table 13 DAC Routing and Control

DAC INTERFACE VOLUME BOOST

A digital gain function is available at the audio interface to boost the DAC volume when a small signal is received on DACDAT. This is controlled using register bits DAC_BOOST [1:0]. To prevent clipping at the DAC input, this function should not be used when the boosted DAC data is expected to be greater than 0dBFS.

The digital interface volume is controlled as shown in Table 14.

REGISTER ADDRESS	BIT	LABEL	DEFAULT	DESCRIPTION
R24 (18h) Audio Interface 0	10:9	DAC_BOOST [1:0]	00	DAC Input Volume Boost 00 = 0dB 01 = +6dB (Input data must not exceed -6dBFS) 10 = +12dB (Input data must not exceed -12dBFS) 11 = +18dB (Input data must not exceed -18dBFS)

Table 14 DAC Interface Volume Boost

DIGITAL-TO-ANALOGUE CONVERTER (DAC)

The WM8912 DACs receive digital input data from the DACDAT pin. The digital audio data is converted to oversampled bit streams in the on-chip, true 24-bit digital interpolation filters. The bitstream data enters two multi-bit, sigma-delta DACs, which convert them to high quality analogue audio signals. The Wolfson SmartDAC™ architecture offers reduced power consumption, whilst also delivering a reduction in high frequency noise and sensitivity to clock jitter. It also uses a Dynamic Element Matching technique for high linearity and low distortion.

The analogue outputs from the DACs are sent directly to the output PGAs (see “Output Signal Path”).

The DACs are enabled by the DACL_ENA and DACR_ENA register bits.

REGISTER ADDRESS	BIT	LABEL	DEFAULT	DESCRIPTION
R18 (12h) Power Management 6	3	DACL_ENA	0	Left DAC Enable 0 = DAC disabled 1 = DAC enabled
	2	DACR_ENA	0	Right DAC Enable 0 = DAC disabled 1 = DAC enabled

Table 15 DAC Enable Control

DAC DIGITAL VOLUME CONTROL

The output level of each DAC can be controlled digitally over a range from -71.625dB to 0dB in 0.375dB steps. The level of attenuation for an eight-bit code is detailed in Table 17.

The DAC_VU bit controls the loading of digital volume control data. When DAC_VU is set to 0, the DACL_VOL or DACR_VOL control data is loaded into the respective control register, but does not actually change the digital gain setting. Both left and right gain settings are updated when a 1 is written to DAC_VU. This makes it possible to update the gain of both channels simultaneously.

REGISTER ADDRESS	BIT	LABEL	DEFAULT	DESCRIPTION
R30 (1Eh) DAC Digital Volume Left	8	DAC_VU	N/A	DAC Volume Update Writing a 1 to this bit causes left and right DAC volume to be updated simultaneously
	7:0	DACL_VOL [7:0]	1100_0000 (0dB)	Left DAC Digital Volume 00h = Mute 01h = -71.625dB 02h = -71.250dB ... (0.375dB steps) C0h to FFh = 0dB (See Table 17 for volume range)
R31 (1Fh) DAC Digital Volume Right	8	DAC_VU	N/A	DAC Volume Update Writing a 1 to this bit causes left and right DAC volume to be updated simultaneously
	7:0	DACR_VOL [7:0]	1100_0000 (0dB)	Right DAC Digital Volume 00h = Mute 01h = -71.625dB 02h = -71.250dB ... (0.375dB steps) C0h to FFh = 0dB (See Table 17 for volume range)

Table 16 DAC Digital Volume Control

DACL_VOL or DACR_VOL	Volume (dB)	DACL_VOL or DACR_VOL	Volume (dB)	DACL_VOL or DACR_VOL	Volume (dB)	DACL_VOL or DACR_VOL	Volume (dB)
0h	MUTE	40h	-48.000	80h	-24.000	C0h	0.000
1h	-71.625	41h	-47.625	81h	-23.625	C1h	0.000
2h	-71.250	42h	-47.250	82h	-23.250	C2h	0.000
3h	-70.875	43h	-46.875	83h	-22.875	C3h	0.000
4h	-70.500	44h	-46.500	84h	-22.500	C4h	0.000
5h	-70.125	45h	-46.125	85h	-22.125	C5h	0.000
6h	-69.750	46h	-45.750	86h	-21.750	C6h	0.000
7h	-69.375	47h	-45.375	87h	-21.375	C7h	0.000
8h	-69.000	48h	-45.000	88h	-21.000	C8h	0.000
9h	-68.625	49h	-44.625	89h	-20.625	C9h	0.000
Ah	-68.250	4Ah	-44.250	8Ah	-20.250	CAh	0.000
Bh	-67.875	4Bh	-43.875	8Bh	-19.875	CBh	0.000
Ch	-67.500	4Ch	-43.500	8Ch	-19.500	CCh	0.000
Dh	-67.125	4Dh	-43.125	8Dh	-19.125	CDh	0.000
Eh	-66.750	4Eh	-42.750	8Eh	-18.750	CEh	0.000
Fh	-66.375	4Fh	-42.375	8Fh	-18.375	CFh	0.000
10h	-66.000	50h	-42.000	90h	-18.000	D0h	0.000
11h	-65.625	51h	-41.625	91h	-17.625	D1h	0.000
12h	-65.250	52h	-41.250	92h	-17.250	D2h	0.000
13h	-64.875	53h	-40.875	93h	-16.875	D3h	0.000
14h	-64.500	54h	-40.500	94h	-16.500	D4h	0.000
15h	-64.125	55h	-40.125	95h	-16.125	D5h	0.000
16h	-63.750	56h	-39.750	96h	-15.750	D6h	0.000
17h	-63.375	57h	-39.375	97h	-15.375	D7h	0.000
18h	-63.000	58h	-39.000	98h	-15.000	D8h	0.000
19h	-62.625	59h	-38.625	99h	-14.625	D9h	0.000
1Ah	-62.250	5Ah	-38.250	9Ah	-14.250	DAh	0.000
1Bh	-61.875	5Bh	-37.875	9Bh	-13.875	DBh	0.000
1Ch	-61.500	5Ch	-37.500	9Ch	-13.500	DCh	0.000
1Dh	-61.125	5Dh	-37.125	9Dh	-13.125	DDh	0.000
1Eh	-60.750	5Eh	-36.750	9Eh	-12.750	DEh	0.000
1Fh	-60.375	5Fh	-36.375	9Fh	-12.375	DFh	0.000
20h	-60.000	60h	-36.000	A0h	-12.000	E0h	0.000
21h	-59.625	61h	-35.625	A1h	-11.625	E1h	0.000
22h	-59.250	62h	-35.250	A2h	-11.250	E2h	0.000
23h	-58.875	63h	-34.875	A3h	-10.875	E3h	0.000
24h	-58.500	64h	-34.500	A4h	-10.500	E4h	0.000
25h	-58.125	65h	-34.125	A5h	-10.125	E5h	0.000
26h	-57.750	66h	-33.750	A6h	-9.750	E6h	0.000
27h	-57.375	67h	-33.375	A7h	-9.375	E7h	0.000
28h	-57.000	68h	-33.000	A8h	-9.000	E8h	0.000
29h	-56.625	69h	-32.625	A9h	-8.625	E9h	0.000
2Ah	-56.250	6Ah	-32.250	AAh	-8.250	EAh	0.000
2Bh	-55.875	6Bh	-31.875	ABh	-7.875	EBh	0.000
2Ch	-55.500	6Ch	-31.500	ACh	-7.500	ECh	0.000
2Dh	-55.125	6Dh	-31.125	ADh	-7.125	EDh	0.000
2Eh	-54.750	6Eh	-30.750	A Eh	-6.750	EEh	0.000
2Fh	-54.375	6Fh	-30.375	AFh	-6.375	EFh	0.000
30h	-54.000	70h	-30.000	B0h	-6.000	F0h	0.000
31h	-53.625	71h	-29.625	B1h	-5.625	F1h	0.000
32h	-53.250	72h	-29.250	B2h	-5.250	F2h	0.000
33h	-52.875	73h	-28.875	B3h	-4.875	F3h	0.000
34h	-52.500	74h	-28.500	B4h	-4.500	F4h	0.000
35h	-52.125	75h	-28.125	B5h	-4.125	F5h	0.000
36h	-51.750	76h	-27.750	B6h	-3.750	F6h	0.000
37h	-51.375	77h	-27.375	B7h	-3.375	F7h	0.000
38h	-51.000	78h	-27.000	B8h	-3.000	F8h	0.000
39h	-50.625	79h	-26.625	B9h	-2.625	F9h	0.000
3Ah	-50.250	7Ah	-26.250	BAh	-2.250	FAh	0.000
3Bh	-49.875	7Bh	-25.875	BBh	-1.875	FBh	0.000
3Ch	-49.500	7Ch	-25.500	BCh	-1.500	FCh	0.000
3Dh	-49.125	7Dh	-25.125	BDh	-1.125	FDh	0.000
3Eh	-48.750	7Eh	-24.750	BEh	-0.750	FEh	0.000
3Fh	-48.375	7Fh	-24.375	BFh	-0.375	FFh	0.000

Table 17 DAC Digital Volume Range

DAC SOFT MUTE AND SOFT UN-MUTE

The WM8912 has a soft mute function. When enabled, this gradually attenuates the volume of the DAC output. When soft mute is disabled, the gain will either gradually ramp back up to the digital gain setting, or return instantly to the digital gain setting, depending on the DAC_UNMUTE_RAMP register bit.

To mute the DAC, this function must be enabled by setting DAC_MUTE to 1.

Soft Mute Mode would typically be enabled (DAC_UNMUTE_RAMP = 1) when using DAC_MUTE during playback of audio data so that when DAC_MUTE is subsequently disabled, the sudden volume increase will not create pop noise by jumping immediately to the previous volume level (e.g. resuming playback after pausing during a track).

Soft Mute Mode would typically be disabled (DAC_UNMUTE_RAMP = 0) when un-muting at the start of a music file, in order that the first part of the track is not attenuated (e.g. when starting playback of a new track, or resuming playback after pausing between tracks).

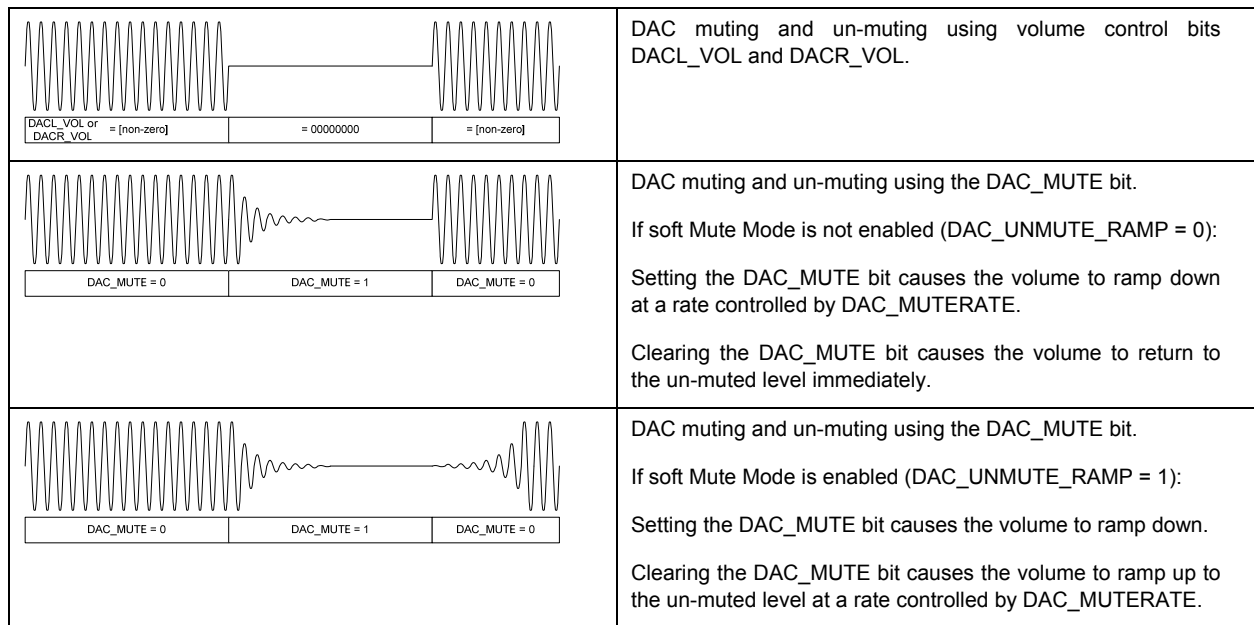

Figure 21 DAC Mute Control

The volume ramp rate during soft mute and un-mute is controlled by the DAC_MUTERATE bit. Ramp rates of fs/32 and fs/2 can be selected, as shown in Table 18. The ramp rate determines the rate at which the volume is increased or decreased. The actual ramp time depends on the extent of the difference between the muted and un-muted volume settings.

REGISTER ADDRESS	BIT	LABEL	DEFAULT	DESCRIPTION
R33 (21h) DAC Digital 1	10	DAC_MUTERATE	0	DAC Soft Mute Ramp Rate 0 = Fast ramp (fs/2, maximum ramp time is 10.7ms at fs=48k) 1 = Slow ramp (fs/32, maximum ramp time is 171ms at fs=48k)
	9	DAC_UNMUTE_RAMP	0	DAC Soft Mute Mode 0 = Disabling soft-mute (DAC_MUTE=0) will cause the DAC volume to change immediately to DACL_VOL and DACR_VOL settings 1 = Disabling soft-mute (DAC_MUTE=0) will cause the DAC volume to ramp up gradually to the DACL_VOL and DACR_VOL settings
	3	DAC_MUTE	1	DAC Soft Mute Control 0 = DAC Un-mute 1 = DAC Mute

Table 18 DAC Soft-Mute Control

DAC MONO MIX

A DAC digital mono-mix mode can be enabled using the DAC_MONO register bit. This mono mix will be output on whichever DAC is enabled. To prevent clipping, a -6dB attenuation is automatically applied to the mono mix.

The mono mix is only supported when one or other DAC is disabled. When the mono mix is selected, then the mono mix is output on the enabled DAC only; there is no output from the disabled DAC. If DACL_ENA and DACR_ENA are both set, then stereo operation applies.

REGISTER ADDRESS	BIT	LABEL	DEFAULT	DESCRIPTION
R33 (21h) DAC Digital 1	12	DAC_MONO	0	DAC Mono Mix 0 = Stereo 1 = Mono (Mono mix output on enabled DAC)

Table 19 DAC Mono Mix

DAC DE-EMPHASIS

Digital de-emphasis can be applied to the DAC playback data (e.g. when the data comes from a CD with pre-emphasis used in the recording). De-emphasis filtering is available for sample rates of 48kHz, 44.1kHz and 32kHz. See "Digital Filter Characteristics" for details of de-emphasis filter characteristics.

REGISTER ADDRESS	BIT	LABEL	DEFAULT	DESCRIPTION
R33 (21h) DAC Digital 1	2:1	DEEMPH [1:0]	00	DAC De-Emphasis Control 00 = No de-emphasis 01 = 32kHz sample rate 10 = 44.1kHz sample rate 11 = 48kHz sample rate

Table 20 DAC De-Emphasis Control

DAC SLOPING STOPBAND FILTER

Two DAC filter types are available, selected by the register bit DAC_SB_FILT. When operating at lower sample rates (e.g. during voice communication) it is recommended that the sloping stopband filter type is selected (DAC_SB_FILT=1) to reduce out-of-band noise which can be audible at low DAC sample rates. See "Digital Filter Characteristics" for details of DAC filter characteristics.

REGISTER ADDRESS	BIT	LABEL	DEFAULT	DESCRIPTION
R33 (21h) DAC Digital 1	11	DAC_SB_FILT	0	Selects DAC filter characteristics 0 = Normal mode 1 = Sloping stopband mode

Table 21 DAC Sloping Stopband Filter**DAC OVERSAMPLING RATIO (OSR)**

The DAC oversampling rate is programmable to allow power consumption versus audio performance trade-offs. The default oversampling rate is low for reduced power consumption; using the higher OSR setting improves the DAC signal-to-noise performance.

REGISTER ADDRESS	BIT	LABEL	DEFAULT	DESCRIPTION
R33 (21h) DAC Digital 1	6	DAC_OS128	0	DAC Oversample Rate Select 0 = Low power (normal OSR) 1 = High performance (double OSR)

Table 22 DAC Oversampling Control

OUTPUT SIGNAL PATH

The outputs HPOUTL and LINEOUTL are derived from the Left DAC output, whilst the outputs HPOUTR and LINEOUTR are derived from the Right DAC output, as illustrated in Figure 22.

A feedback path for common mode noise rejection is provided at HPOUTFB and LINEOUTFB for the Headphone and Line outputs respectively. This pin must be connected to ground for normal operation.

Each analogue output can be separately enabled; independent volume control is also provided for each output. The signal paths and associated control registers are illustrated in Figure 22.

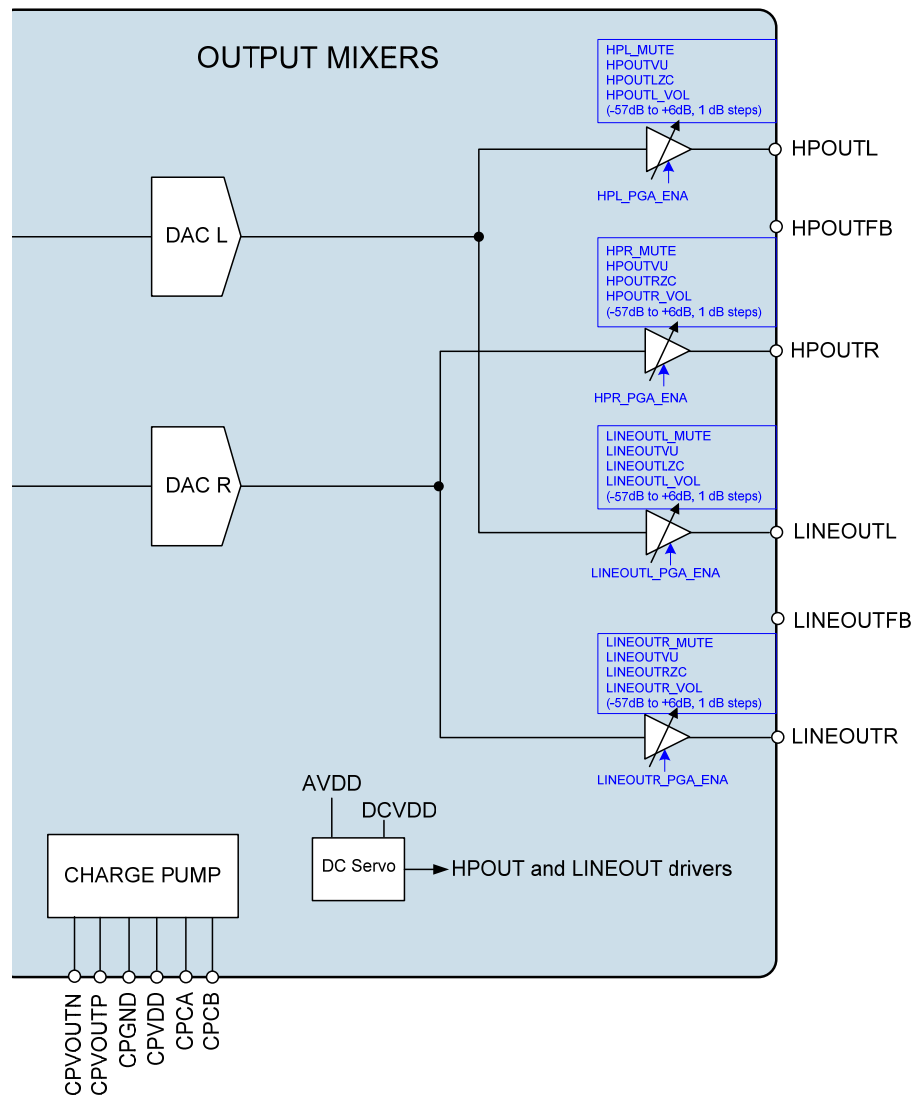

Figure 22 Output Signal Path and Control Registers

OUTPUT SIGNAL PATHS ENABLE

The output PGAs for each analogue output pin can be enabled and disabled using the register bits described in Table 23.

Note that the Headphone Outputs and Line Outputs are also controlled by fields located within Register R90 and R94, which provide suppression of pops & clicks when enabling and disabling these signal paths. These registers are described in the following "Headphone / Line Output Signal Paths Enable" section.

Under recommended usage conditions, all the control bits associated with enabling the Headphone Outputs and the Line Outputs will be configured by scheduling the default Start-Up and Shutdown sequences as described in the "Control Write Sequencer" section. In these cases, the user does not need to set the register fields in R14, R15, R90 and R94 directly.

REGISTER ADDRESS	BIT	LABEL	DEFAULT	DESCRIPTION
R14 (0Eh) Power Management 2	1	HPL_PGA_ENA	0	Left Headphone Output Enable 0 = disabled 1 = enabled
	0	HPR_PGA_ENA	0	Right Headphone Output Enable 0 = disabled 1 = enabled
R15 (0Fh) Power Management 3	1	LINEOUTL_PGA_ENA	0	Left Line Output Enable 0 = disabled 1 = enabled
	0	LINEOUTR_PGA_ENA	0	Right Line Output Enable 0 = disabled 1 = enabled

Table 23 Output Signal Paths Enable

Note that, to enable the output PGAs and multiplexers, the reference voltage VMID and the bias current must also be enabled. See "Reference Voltages and Master Bias" for details of the associated controls VMID_RES and BIAS_ENA.

HEADPHONE / LINE OUTPUT SIGNAL PATHS ENABLE

The output paths can be actively discharged to AGND through internal resistors if desired. This is desirable at start-up in order to achieve a known output stage condition prior to enabling the VMID reference voltage. This is also desirable in shutdown to prevent the external connections from being affected by the internal circuits. The ground-referenced Headphone outputs and Line outputs are shorted to AGND by default; the short circuit is removed on each of these paths by setting the applicable fields HPL_RMV_SHORT, HPR_RMV_SHORT, LINEOUTL_RMV_SHORT or LINEOUTR_RMV_SHORT.

The ground-referenced Headphone output and Line output drivers are designed to suppress pops and clicks when enabled or disabled. However, it is necessary to control the drivers in accordance with a defined sequence in start-up and shutdown to achieve the pop suppression. It is also necessary to schedule the DC Servo offset correction at the appropriate point in the sequence (see "DC Servo"). Table 24 and Table 25 describe the recommended sequences for enabling and disabling these output drivers.

SEQUENCE	HEADPHONE ENABLE	LINEOUT ENABLE
Step 1	HPL_ENA = 1 HPR_ENA = 1	LINEOUTL_ENA = 1 LINEOUTR_ENA = 1
Step 2	HPL_ENA_DLY = 1 HPR_ENA_DLY = 1	LINEOUTL_ENA_DLY = 1 LINEOUTR_ENA_DLY = 1
Step 3	DC offset correction	DC offset correction
Step 4	HPL_ENA_OUTP = 1 HPR_ENA_OUTP = 1	LINEOUTL_ENA_OUTP = 1 LINEOUTR_ENA_OUTP = 1
Step 5	HPL_RMV_SHORT = 1 HPR_RMV_SHORT = 1	LINEOUTL_RMV_SHORT = 1 LINEOUTR_RMV_SHORT = 1

Table 24 Headphone / Line Output Enable Sequence

SEQUENCE	HEADPHONE DISABLE	LINEOUT DISABLE
Step 1	HPL_RMV_SHORT = 0 HPR_RMV_SHORT = 0	LINEOUTL_RMV_SHORT = 0 LINEOUTR_RMV_SHORT = 0
Step 2	HPL_ENA = 0 HPL_ENA_DLY = 0 HPL_ENA_OUTP = 0 HPR_ENA = 0 HPR_ENA_DLY = 0 HPR_ENA_OUTP = 0	LINEOUTL_ENA = 0 LINEOUTL_ENA_DLY = 0 LINEOUTL_ENA_OUTP = 0 LINEOUTR_ENA = 0 LINEOUTR_ENA_DLY = 0 LINEOUTR_ENA_OUTP = 0

Table 25 Headphone / Line Output Disable Sequence

The register bits relating to pop suppression control are defined in Table 26 below.

REGISTER ADDRESS	BIT	LABEL	DEFAULT	DESCRIPTION
R90 (5Ah) Analogue HP 0	7	HPL_RMV_SHORT	0	Removes HPL short 0 = HPL short enabled 1 = HPL short removed For normal operation, this bit should be set as the final step of the HPL Enable sequence.
	6	HPL_ENA_OUTP	0	Enables HPL output stage 0 = Disabled 1 = Enabled For normal operation, this bit should be set to 1 after the DC offset cancellation has been scheduled.
	5	HPL_ENA_DLY	0	Enables HPL intermediate stage 0 = Disabled 1 = Enabled For normal operation, this bit should be set to 1 after the output signal path has been configured, and before DC offset cancellation is scheduled. This bit should be set with at least 20us delay after HPL_ENA.

REGISTER ADDRESS	BIT	LABEL	DEFAULT	DESCRIPTION
	4	HPL_ENA	0	Enables HPL input stage 0 = Disabled 1 = Enabled For normal operation, this bit should be set as the first step of the HPL Enable sequence.
	3	HPR_RMV_SHORT	0	Removes HPR short 0 = HPR short enabled 1 = HPR short removed For normal operation, this bit should be set as the final step of the HPR Enable sequence.
	2	HPR_ENA_OUTP	0	Enables HPR output stage 0 = Disabled 1 = Enabled For normal operation, this bit should be set to 1 after the DC offset cancellation has been scheduled.
	1	HPR_ENA_DLY	0	Enables HPR intermediate stage 0 = Disabled 1 = Enabled For normal operation, this bit should be set to 1 after the output signal path has been configured, and before DC offset cancellation is scheduled. This bit should be set with at least 20us delay after HPR_ENA.
	0	HPR_ENA	0	Enables HPR input stage 0 = Disabled 1 = Enabled For normal operation, this bit should be set as the first step of the HPR Enable sequence.
R94 (5Eh) Analogue Lineout 0	7	LINEOUTL_RMV_SHORT	0	Removes LINEOUTL short 0 = LINEOUTL short enabled 1 = LINEOUTL short removed For normal operation, this bit should be set as the final step of the LINEOUTL Enable sequence.
	6	LINEOUTL_ENA_OUTP	0	Enables LINEOUTL output stage 0 = Disabled 1 = Enabled For normal operation, this bit should be set to 1 after the DC offset cancellation has been scheduled.
	5	LINEOUTL_ENA_DLY	0	Enables LINEOUTL intermediate stage 0 = Disabled 1 = Enabled For normal operation, this bit should be set to 1 after the output signal path has been configured, and before DC offset cancellation is scheduled. This bit should be set with at least 20us delay after LINEOUTL_ENA.

REGISTER ADDRESS	BIT	LABEL	DEFAULT	DESCRIPTION
	4	LINEOUTL_ENA	0	Enables LINEOUTL input stage 0 = Disabled 1 = Enabled For normal operation, this bit should be set as the first step of the LINEOUTL Enable sequence.
	3	LINEOUTR_RMV_SHORT	0	Removes LINEOUTR short 0 = LINEOUTR short enabled 1 = LINEOUTR short removed For normal operation, this bit should be set as the final step of the LINEOUTR Enable sequence.
	2	LINEOUTR_ENA_OUTP	0	Enables LINEOUTR output stage 0 = Disabled 1 = Enabled For normal operation, this bit should be set to 1 after the DC offset cancellation has been scheduled.
	1	LINEOUTR_ENA_DLY	0	Enables LINEOUTR intermediate stage 0 = Disabled 1 = Enabled For normal operation, this bit should be set to 1 after the output signal path has been configured, and before DC offset cancellation is scheduled. This bit should be set with at least 20us delay after LINEOUTR_ENA.
	0	LINEOUTR_ENA	0	Enables LINEOUTR input stage 0 = Disabled 1 = Enabled For normal operation, this bit should be set as the first step of the LINEOUTR Enable sequence.

Table 26 Headphone / Line Output Pop Suppression Control

OUTPUT VOLUME CONTROL

Each analogue output can be independently controlled using the registers described in Table 27 (for Headphone outputs) and Table 28 (for Line outputs). See also the “Analogue Outputs” section for details of these output pins, including recommended external components.

The volume and mute status of each analogue output can be controlled individually using the register bits described in Table 27 and Table 28.

To prevent “zipper noise” when a volume adjustment is made, a zero-cross function is provided on all output paths. When this function is enabled, volume updates will not take place until a zero-crossing is detected. In the event of a long period without zero-crossings, a timeout will apply. The timeout must be enabled by setting the TOCLK_ENA bit, as defined in “Clocking and Sample Rates”.

The volume update bits control the loading of the output driver volume data. For example, when HPOUT_VU is set to 0, the headphone volume data can be loaded into the respective control register, but will not actually change the gain setting. The Left and Right headphone volume settings are updated when a 1 is written to HPOUT_VU. This makes it possible to update the gain of a Left/Right pair of output paths simultaneously.

REGISTER ADDRESS	BIT	LABEL	DEFAULT	DESCRIPTION
R57 (39h) Analogue OUT1 Left	8	HPOUTL_MUTE	0	Left Headphone Output Mute 0 = Un-mute 1 = Mute
	7	HPOUT_VU	0	Headphone Output Volume Update Writing a 1 to this bit will update HPOUTL and HPOUTR volumes simultaneously.
	6	HPOUTLZC	0	Left Headphone Output Zero Cross Enable 0 = disabled 1 = enabled
	5:0	HPOUTL_VOL [5:0]	10_1101	Left Headphone Output Volume 000000 = -57dB 000001 = -56dB (... 1dB steps) 111001 = 0dB (... 1dB steps) 111110 = +5dB 111111 = +6dB
R58 (3Ah) Analogue OUT1 Right	8	HPOUTR_MUTE	0	Right Headphone Output Mute 0 = Un-mute 1 = Mute
	7	HPOUT_VU	0	Headphone Output Volume Update Writing a 1 to this bit will update HPOUTL and HPOUTR volumes simultaneously.
	6	HPOUTRZC	0	Right Headphone Output Zero Cross Enable 0 = disabled 1 = enabled
	5:0	HPOUTR_VOL [5:0]	10_1101	Right Headphone Output Volume 000000 = -57dB 000001 = -56dB (... 1dB steps) 111001 = 0dB (... 1dB steps) 111110 = +5dB 111111 = +6dB

Table 27 Volume Control for HPOUTL and HPOUTR

REGISTER ADDRESS	BIT	LABEL	DEFAULT	DESCRIPTION
R59 (3Bh) Analogue OUT2 Left	8	LINEOUTL_MUTE	0	Left Line Output Mute 0 = Un-mute 1 = Mute
	7	LINEOUT_VU	0	Line Output Volume Update Writing a 1 to this bit will update LINEOUTL and LINEOUTR volumes simultaneously.
	6	LINEOUTLZC	0	Left Line Output Zero Cross Enable 0 = disabled 1 = enabled
	5:0	LINEOUTL_VOL [5:0]	11_1001	Left Line Output Volume 000000 = -57dB 000001 = -56dB (... 1dB steps) 111001 = 0dB (... 1dB steps) 111110 = +5dB 111111 = +6dB
R60 (3Ch) Analogue OUT2 Right	8	LINEOUTR_MUTE	0	Right Line Output Mute 0 = Un-mute 1 = Mute
	7	LINEOUT_VU	0	Line Output Volume Update Writing a 1 to this bit will update LINEOUTL and LINEOUTR volumes simultaneously.
	6	LINEOUTRZC	0	Right Line Output Zero Cross Enable 0 = disabled 1 = enabled
	5:0	LINEOUTR_VOL [5:0]	11_1001	Right Line Output Volume 000000 = -57dB 000001 = -56dB (... 1dB steps) 111001 = 0dB (... 1dB steps) 111110 = +5dB 111111 = +6dB

Table 28 Volume Control for LINEOUTL and LINEOUTR

ANALOGUE OUTPUTS

The WM8912 has four analogue output pins:

- Headphone outputs, HPOUTL and HPOUTR, with feedback HPOUTFB
- Line outputs, LINEOUTL and LINEOUTR, with feedback LINEOUTFB

The output signal paths and associated control registers are illustrated in Figure 22.

HEADPHONE OUTPUTS – HPOUTL AND HPOUTR

The headphone outputs are designed to drive 16 Ω or 32 Ω headphones. These outputs are ground-referenced, i.e. no series capacitor is required between the pins and the headphone load. They are powered by an on-chip charge pump (see “Charge Pump” section). Signal volume at the headphone outputs is controlled as shown in Table 27.

The ground-referenced outputs incorporates a common mode, or ground loop, feedback path which provides rejection of system-related ground noise. The return path for the HPOUTL and HPOUTR outputs is via HPOUTFB. This pin must be connected to ground for normal operation of the headphone output. No register configuration is required.

LINE OUTPUTS – LINEOUTL AND LINEOUTR

The line outputs are identical to the headphone outputs in design. They are ground-referenced and powered by the on-chip charge pump. Signal volume at the line outputs is controlled as shown in Table 28.

Note that these outputs are intended for driving line loads, as the charge pump powering both the Headphone and Line outputs can only provide sufficient power to drive one set of headphones at any given time.

The ground-referenced outputs incorporates a common mode, or ground loop, feedback path which provides rejection of system-related ground noise. The return path for the LINEOUTL and LINEOUTR outputs is via LINEOUTFB. This pin must be connected to ground for normal operation of the line output. No register configuration is required.

EXTERNAL COMPONENTS FOR GROUND REFERENCED OUTPUTS

It is recommended to connect a zobel network to the ground-referenced outputs HPOUTL, HPOUTR, LINEOUTL and LINEOUTR in order to ensure best audio performance in all applications. The components of the zobel network have the effect of dampening high frequency oscillations or instabilities that can arise outside the audio band under certain conditions. Possible sources of these instabilities include the inductive load of a headphone coil or an active load in the form of an external line amplifier. The capacitance of lengthy cables or PCB tracks can also lead to amplifier instability. The zobel network should comprise of a 20Ω resistor and 100nF capacitor in series with each other, as illustrated in Figure 23.

Note that the zobel network is recommended for best audio quality and amplifier stability in all cases.

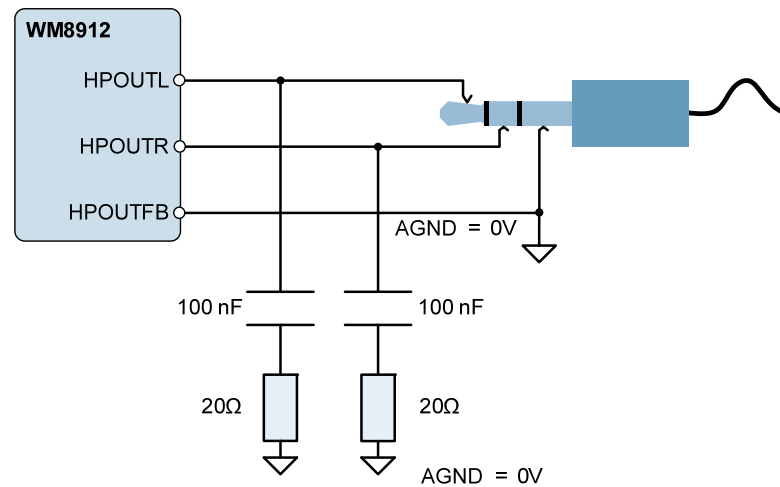

Figure 23 Zobel Network Components for HPOUTL, HPOUTR, LINEOUTL and LINEOUTR

REFERENCE VOLTAGES AND MASTER BIAS

This section describes the analogue reference voltage and bias current controls. Note that, under the recommended usage conditions of the WM8912, these features will be configured by scheduling the default Start-Up and Shutdown sequences as described in the “Control Write Sequencer” section. In these cases, the user does not need to set these register fields directly.

The analogue circuits in the WM8912 require a mid-rail analogue reference voltage, VMID. This reference is generated from AVDD via a programmable resistor chain.

VMID is enabled by setting the VMID_ENA register bit. The programmable resistor chain is configured by VMID_RES [1:0], and can be used to optimise the reference for normal operation, low power standby or for fast start-up as described in Table 29. For normal operation, the VMID_RES field should be set to 01.

The analogue circuits in the WM8912 require a bias current. The normal bias current is enabled by setting BIAS_ENA. Note that the normal bias current source requires VMID to be enabled also.

REGISTER ADDRESS	BIT	LABEL	DEFAULT	DESCRIPTION
R5 (05h) VMID Control (0)	2:1	VMID_RES [1:0]	00	VMID Divider Enable and Select 00 = VMID disabled (for OFF mode) 01 = 2 x 50k divider (for normal operation) 10 = 2 x 250k divider (for low power standby) 11 = 2 x 5k divider (for fast start-up)
	0	VMID_ENA	0	Enable VMID master bias current source 0 = Disabled 1 = Enabled
R4 (04h) Bias Control (0)	0	BIAS_ENA	0	Enables the Normal bias current generator (for all analogue functions) 0 = Disabled 1 = Enabled

Table 29 Reference Voltages and Master Bias Enable

CHARGE PUMP

The WM8912 incorporates a dual-mode Charge Pump which generates the supply rails for the headphone and line output drivers, HPOUTL, HPOUTR, and LINEOUTL and LINEOUTR. The Charge Pump has a single supply input, CPVDD, and generates split rails CPVOUTP and CPVOUTN according to the selected mode of operation. The Charge Pump connections are illustrated in Figure 24 (see the “Electrical Characteristics” section for external component values). An input decoupling capacitor may also be required at CPVDD, depending upon the system configuration.

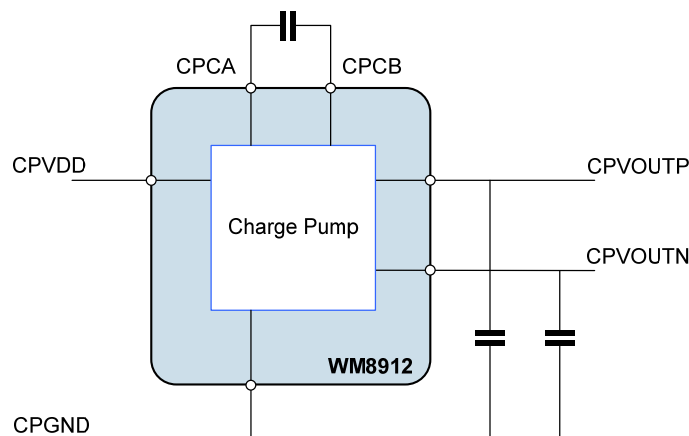

Figure 24 Charge Pump External Connections

The Charge Pump is enabled by setting the CP_ENA bit. When enabled, the charge pump adjusts the output voltages (CPVOUTP and CPVOUTN) as well as the switching frequency in order to optimise the power consumption according to the operating conditions. This can take two forms, which are selected using the CP_DYN_PWR register bit.

- Register control (CP_DYN_PWR = 0)
- Dynamic control (CP_DYN_PWR = 1)

Under Register control, the HPOUTL_VOL, HPOUTR_VOL, LINEOUTL_VOL and LINEOUTR_VOL register settings are used to control the charge pump mode of operation.

Under Dynamic control, the audio signal level in the DAC is used to control the charge pump mode of operation. This is the Wolfson 'Class W' mode, which allows the power consumption to be optimised in real time.

Under the recommended usage conditions of the WM8912, the Charge Pump will be enabled by running the default headphone Start-Up sequence as described in the "Control Write Sequencer" section. (Similarly, it will be disabled by running the Shutdown sequence.) In these cases, the user does not need to write to the CP_ENA bit. The Charge Pump operating mode defaults to Register control; Dynamic control may be selected by setting the CP_DYN_PWR register bit, if appropriate.

Note that the charge pump clock is derived from internal clock SYSCLK; this may be derived from MCLK directly or else using the FLL output, as determined by the SYSCLK_SRC bit. Under normal circumstances an external clock signal must be present for the charge pump to function. However, the FLL has a free-running mode that does not require an external clock but will generate an internal clock suitable for running the charge pump. The clock division from SYSCLK is handled transparently by the WM8912 without user intervention, as long as SYSCLK and sample rates are set correctly. Refer to the "Clocking and Sample Rates" section for more detail on the FLL and clocking configuration.

The Charge Pump control fields are described in Table 30.

REGISTER ADDRESS	BIT	LABEL	DEFAULT	DESCRIPTION
R98 (62h) Charge Pump 0	0	CP_ENA	0	Enable charge-pump digits 0 = disable 1 = enable
R104 (68h) Class W (0)	0	CP_DYN_PWR	0	Enable dynamic charge pump power control 0 = Charge pump controlled by volume register settings (Class G) 1 = Charge pump controlled by real-time audio level (Class W) Class W is recommended for lowest power consumption

Table 30 Charge Pump Control

DC SERVO

The WM8912 provides four DC servo circuits, two on the headphone outputs HPOUTL and HPOUTR and two on the line outputs LINEOUTL and LINEOUTR, to remove DC offset from these ground-referenced outputs. When enabled, the DC servos ensure that the DC level of these outputs remains within 1mV of ground. Removal of the DC offset is important because any deviation from GND at the output pin will cause current to flow through the load under quiescent conditions, resulting in increased power consumption. Additionally, the presence of DC offsets can result in audible pops and clicks at power up and power down.

The recommended usage of the DC Servo is initialised by scheduling the default Start-Up sequence as described in the “Control Write Sequencer” section. The default Start-Up sequence executes a series of DC offset corrections, after which the measured offset correction is maintained on the headphone output channels. If a different usage is required, e.g. if a periodic DC offset correction is required, then the default Start-Up sequence may be modified according to specific requirements. The relevant control fields are described in the following paragraphs and are defined in Table 31.

DC SERVO ENABLE AND START-UP

The DC Servo circuits are enabled on HPOUTL and HPOUTR by setting DCS_ENA_CHAN_0 and DCS_ENA_CHAN_1 respectively. Similarly, the DC Servo circuits are enabled on LINEOUTL and LINEOUTR by setting DCS_ENA_CHAN_2 and DCS_ENA_CHAN_3 respectively. When the DC Servo is enabled, the DC offset correction can be commanded in a number of different ways, including single-shot and periodically recurring events.

Writing a logic 1 to DCS_TRIG_STARTUP_*n* initiates a series of DC offset measurements and applies the necessary correction to the associated output; (*n* = 3 for LINEOUTR channel, 2 for LINEOUTL channel, 1 for HPOUTR channel, 0 for HPOUTL channel). On completion, the output will be within 1mV of AGND. This is the DC Servo mode selected by the default Start-Up sequence. Completion of the DC offset correction triggered in this way is indicated by the DCS_STARTUP_COMPLETE field, as described in Table 31. Typically, this operation takes 86ms per channel.

Writing a logic 1 to DCS_TRIG_DAC_WR_*n* causes the DC offset correction to be set to the value contained in the DCS_DAC_WR_VAL_*n* fields in Registers R73 to R76. This mode is useful if the required offset correction has already been determined and stored; it is faster than the DCS_TRIG_STARTUP_*n* mode, but relies on the accuracy of the stored settings. Completion of the DC offset correction triggered in this way is indicated by the DCS_DAC_WR_COMPLETE field, as described in Table 31. Typically, this operation takes 2ms per channel.

When using either of the DC Servo options above, the status of the DC offset correction process is indicated by the DCS_CAL_COMPLETE field; this is the logical OR of the DCS_STARTUP_COMPLETE and DCS_DAC_WR_COMPLETE fields.

The DC Servo control fields associated with start-up operation are described in Table 31. It is important to note that, to minimise audible pops/clicks, the Start-Up and DAC Write modes of DC Servo operation should be commanded as part of a control sequence which includes muting and shorting of the headphone outputs; a suitable sequence is defined in the default Start-Up sequence.

REGISTER ADDRESS	BIT	LABEL	DEFAULT	DESCRIPTION
R68 (44h) DC Servo 1	7	DCS_TRIG_STARTUP_3	0	Writing 1 to this bit selects Start-Up DC Servo mode for LINEOUTR. In readback, a value of 1 indicates that the DC Servo Start-Up correction is in progress.
	6	DCS_TRIG_STARTUP_2	0	Writing 1 to this bit selects Start-Up DC Servo mode for LINEOUTL. In readback, a value of 1 indicates that the DC Servo Start-Up correction is in progress.

REGISTER ADDRESS	BIT	LABEL	DEFAULT	DESCRIPTION
	5	DCS_TRIG_STARTUP_1	0	Writing 1 to this bit selects Start-Up DC Servo mode for HPOUTR. In readback, a value of 1 indicates that the DC Servo Start-Up correction is in progress.
	4	DCS_TRIG_STARTUP_0	0	Writing 1 to this bit selects Start-Up DC Servo mode for HPOUTL. In readback, a value of 1 indicates that the DC Servo Start-Up correction is in progress.
	3	DCS_TRIG_DAC_WR_3	0	Writing 1 to this bit selects DAC Write DC Servo mode for LINEOUTR. In readback, a value of 1 indicates that the DC Servo DAC Write correction is in progress.
	2	DCS_TRIG_DAC_WR_2	0	Writing 1 to this bit selects DAC Write DC Servo mode for LINEOUTL. In readback, a value of 1 indicates that the DC Servo DAC Write correction is in progress.
	1	DCS_TRIG_DAC_WR_1	0	Writing 1 to this bit selects DAC Write DC Servo mode for HPOUTR. In readback, a value of 1 indicates that the DC Servo DAC Write correction is in progress.
	0	DCS_TRIG_DAC_WR_0	0	Writing 1 to this bit selects DAC Write DC Servo mode for HPOUTL. In readback, a value of 1 indicates that the DC Servo DAC Write correction is in progress.
R67 (43h) DC Servo 0	3	DCS_ENA_CHAN_3	0	DC Servo enable for LINEOUTR 0 = disabled 1 = enabled
	2	DCS_ENA_CHAN_2	0	DC Servo enable for LINEOUTL 0 = disabled 1 = enabled
	1	DCS_ENA_CHAN_1	0	DC Servo enable for HPOUTR 0 = disabled 1 = enabled
	0	DCS_ENA_CHAN_0	0	DC Servo enable for HPOUTL 0 = disabled 1 = enabled
R73 (49h) DC Servo 6	7:0	DCS_DAC_WR_VAL_3 [7:0]	0000 0000	DC Offset value for LINEOUTR in DAC Write DC Servo mode in two's complement format. In readback, the current DC offset value is returned in two's complement format. Two's complement format: LSB is 0.25mV. Range is +/-32mV

REGISTER ADDRESS	BIT	LABEL	DEFAULT	DESCRIPTION
R74 (4Ah) DC Servo 7	7:0	DCS_DAC_WR_V AL_2 [7:0]	0000 0000	DC Offset value for LINEOUTL in DAC Write DC Servo mode in two's complement format. In readback, the current DC offset value is returned in two's complement format. Two's complement format: LSB is 0.25mV. Range is +/-32mV
R75 (4Bh) DC Servo 8	7:0	DCS_DAC_WR_V AL1 [7:0]	0000 0000	DC Offset value for HPOUTR in DAC Write DC Servo mode in two's complement format. In readback, the current DC offset value is returned in two's complement format. Two's complement format: LSB is 0.25mV. Range is +/-32mV
R76 (4Ch) DC Servo 9	7:0	DCS_DAC_WR_V AL0 [7:0]	0000 0000	DC Offset value for HPOUTL in DAC Write DC Servo mode in two's complement format. In readback, the current DC offset value is returned in two's complement format. Two's complement format: LSB is 0.25mV. Range is +/-32mV
R77 (4Dh) DC Servo Readback 0	11:8	DCS_CAL_COMP LETE [3:0]	0000	DC Servo Complete status [3] - LINEOUTR [2] - LINEOUTL [1] - HPOUTR [0] - HPOUTL 0 = DAC Write or Start-Up DC Servo mode not completed. 1 = DAC Write or Start-Up DC Servo mode complete.
	7:4	DCS_DAC_WR_C COMPLETE [3:0]	0000	DC Servo DAC Write status [3] - LINEOUTR [2] - LINEOUTL [1] - HPOUTR [0] - HPOUTL 0 = DAC Write DC Servo mode not completed. 1 = DAC Write DC Servo mode complete.

REGISTER ADDRESS	BIT	LABEL	DEFAULT	DESCRIPTION
	3:0	DCS_STARTUP_COMPLETE [3:0]	0000	DC Servo Start-Up status [3] - LINEOUTR [2] - LINEOUTL [1] - HPOUTR [0] - HPOUTL 0 = Start-Up DC Servo mode not completed.. 1 = Start-Up DC Servo mode complete.

Table 31 DC Servo Enable and Start-Up Modes

DC SERVO ACTIVE MODES

The DC Servo modes described above are suitable for initialising the DC offset correction circuit on the Line and Headphone outputs as part of a controlled start-up sequence which is executed before the signal path is fully enabled. Additional modes are available for use whilst the signal path is active; these modes may be of benefit following a large change in signal gain, which can lead to a change in DC offset level. Periodic updates may also be desirable to remove slow drifts in DC offset caused by changes in parameters such as device temperature.

The DC Servo circuit is enabled on HPOUTR and HPOUTL by setting DCS_ENA_CHAN_1 and DCS_ENA_CHAN_0 respectively, as described earlier in Table 31. Similarly, the DC Servo circuit is enabled on LINEOUTR and LINEOUTL by setting DCS_ENA_CHAN_3 and DCS_ENA_CHAN_2 respectively.

Writing a logic 1 to DCS_TRIG_SINGLE_*n* initiates a single DC offset measurement and adjustment to the associated output; ('n' = 3 for LINEOUTR channel, 2 for LINEOUTL channel, 1 for HPOUTR channel, 0 for HPOUTL channel). This will adjust the DC offset correction on the selected channel by no more than 1LSB (0.25mV).

Setting DCS_TIMER_PERIOD_01 or DCS_TIMER_PERIOD_23 to a non-zero value will cause a single DC offset measurement and adjustment to be scheduled on a periodic basis. Periodic rates ranging from every 0.52s to in excess of 2 hours can be selected.

Writing a logic 1 to DCS_TRIG_SERIES_*n* initiates a series of DC offset measurements and applies the necessary correction to the associated output. The number of DC Servo operations performed is determined by DCS_SERIES_NO_01 or DCS_SERIES_NO_23. A maximum of 128 operations may be selected, though a much lower value will be sufficient in most applications.

The DC Servo control fields associated with active modes (suitable for use on a signal path that is in active use) are described in Table 32.

REGISTER ADDRESS	BIT	LABEL	DEFAULT	DESCRIPTION
R68 (44h) DC Servo 1	15	DCS_TRIG_SING LE_3	0	Writing 1 to this bit selects a single DC offset correction for LINEOUTR. In readback, a value of 1 indicates that the DC Servo single correction is in progress.
	14	DCS_TRIG_SING LE_2	0	Writing 1 to this bit selects a single DC offset correction for LINEOUTL. In readback, a value of 1 indicates that the DC Servo single correction is in progress.
	13	DCS_TRIG_SING LE_1	0	Writing 1 to this bit selects a single DC offset correction for HPOUTR. In readback, a value of 1 indicates that the DC Servo single correction is in progress.

REGISTER ADDRESS	BIT	LABEL	DEFAULT	DESCRIPTION
	12	DCS_TRIG_SING LE_0	0	Writing 1 to this bit selects a single DC offset correction for HPOUTL. In readback, a value of 1 indicates that the DC Servo single correction is in progress.
	11	DCS_TRIG_SERI ES_3	0	Writing 1 to this bit selects a series of DC offset corrections for LINEOUTR. In readback, a value of 1 indicates that the DC Servo DAC Write correction is in progress.
	10	DCS_TRIG_SERI ES_2	0	Writing 1 to this bit selects a series of DC offset corrections for LINEOUTL. In readback, a value of 1 indicates that the DC Servo DAC Write correction is in progress.
	9	DCS_TRIG_SERI ES_1	0	Writing 1 to this bit selects a series of DC offset corrections for HPOUTR. In readback, a value of 1 indicates that the DC Servo DAC Write correction is in progress.
	8	DCS_TRIG_SERI ES_0	0	Writing 1 to this bit selects a series of DC offset corrections for HPOUTL. In readback, a value of 1 indicates that the DC Servo DAC Write correction is in progress.
R71 (47h) DC Servo 4	6:0	DCS_SERIES_N O_23 [6:0]	010_1010	Number of DC Servo updates to perform in a series event for LINEOUTL/LINEOUTR. 0 = 1 updates 1 = 2 updates ... 127 = 128 updates
R72 (48h) DC Servo 5	6:0	DCS_SERIES_N O_01 [6:0]	010 1010	Number of DC Servo updates to perform in a series event for HPOUTL/HPOUTR. 0 = 1 updates 1 = 2 updates ... 127 = 128 updates
R69 (45h) DC Servo 2	11:8	DCS_TIMER_PE RIOD_23 [3:0]	1010	Time between periodic updates for LINEOUTL/LINEOUTR. Time is calculated as $0.256s \times (2^{\wedge}PERIOD)$ 0000 = Off 0001 = 0.52s 1010 = 266s (4min 26s) 1111 = 8519s (2hr 22s)
	3:0	DCS_TIMER_PE RIOD_01 [3:0]	1010	Time between periodic updates for HPOUTL/HPOUTR. Time is calculated as $0.256s \times (2^{\wedge}PERIOD)$ 0000 = Off 0001 = 0.52s 1010 = 266s (4min 26s) 1111 = 8519s (2hr 22s)

Table 32 DC Servo Active Modes

DC SERVO READBACK

The current DC offset value for each Line and Headphone output channel can be read in two's complement format from the DCS_DAC_WR_VAL_n [7:0] bit fields in Registers R73, R74, R75 and R76. Note that these values may form the basis of settings that are subsequently used by the DC Servo in DAC Write mode.

DIGITAL AUDIO INTERFACE

The digital audio interface is used for inputting DAC data to the WM8912. The digital audio interface uses three pins:

- DACDAT: DAC data input
- LRCLK: Left/Right data alignment clock
- BCLK: Bit clock, for synchronisation

The clock signals BCLK and LRCLK can be outputs when the WM8912 operates as a master, or inputs when it is a slave (see "Master and Slave Mode Operation", below).

Four different audio data formats are supported:

- Left justified
- Right justified
- I2S
- DSP mode

All four of these modes are MSB first. They are described in "Audio Data Formats (Normal Mode)", below. Refer to the "Signal Timing Requirements" section for timing information.

Time Division Multiplexing (TDM) is available in all four data format modes. The WM8912 can be programmed to receive data in one of two time slots.

PCM operation is supported using the DSP mode.

MASTER AND SLAVE MODE OPERATION

The WM8912 digital audio interface can operate in master or slave mode, as shown in Figure 25 and Figure 26.

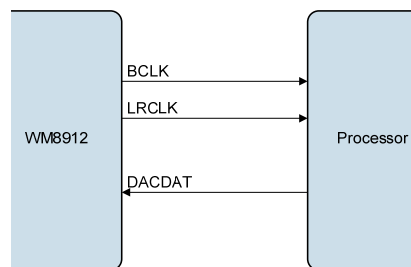

Figure 25 Master Mode

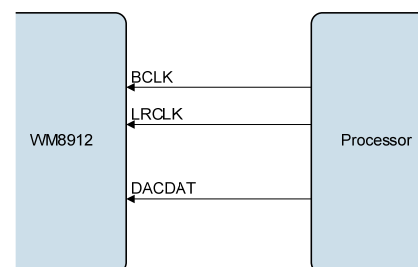

Figure 26 Slave Mode

In master mode, BCLK is derived from SYSCLK via a programmable division set by BCLK_DIV.

In master mode, LRCLK is derived from BCLK via a programmable division set by LRCLK_RATE. The BCLK input to this divider may be internal or external, allowing mixed master and slave modes.

The direction of these signals and the clock frequencies are controlled as described in the “Digital Audio Interface Control” section.

BCLK and LRCLK can be enabled as outputs in Slave mode, allowing mixed Master/Slave operation - see “Digital Audio Interface Control”.

OPERATION WITH TDM

Time division multiplexing (TDM) allows multiple devices to transfer data simultaneously on the same bus. The WM8912 supports TDM in master and slave modes for all data formats and word lengths. TDM is enabled and configured using register bits defined in the “Digital Audio Interface Control” section.

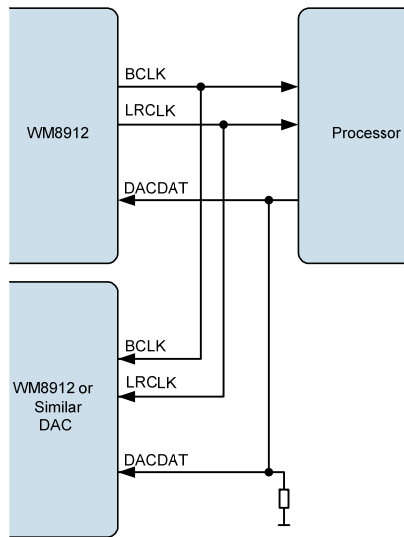

Figure 27 TDM with WM8912 as Master

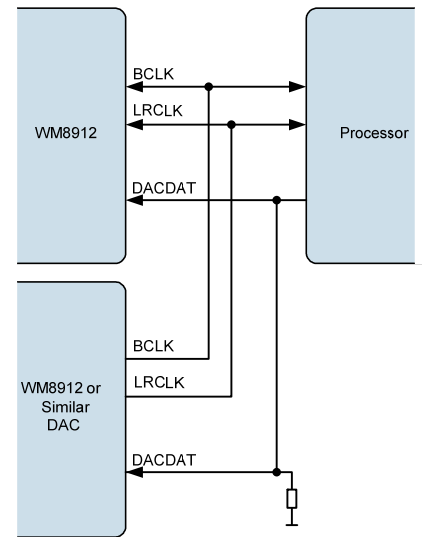

Figure 28 TDM with other DAC as Master

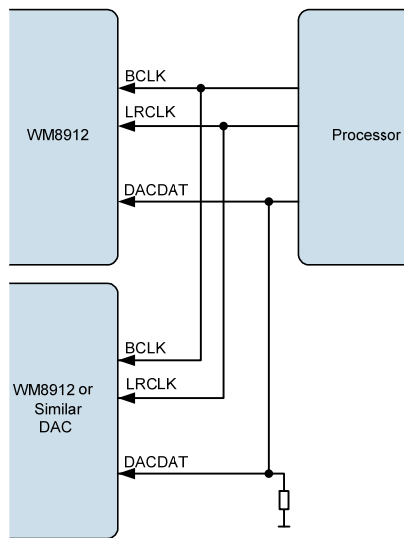

Figure 29 TDM with Processor as Master

Note: The WM8912 is a 24-bit device. If the user operates the WM8912 in 32-bit mode then the 8 LSBs will be ignored on the DAC input. It is recommended to add a pull-down resistor to the DACDAT line in TDM mode in this case.

BCLK FREQUENCY

The BCLK frequency is controlled relative to SYCLK by the BCLK_DIV divider. Internal clock divide and phase control mechanisms ensure that the BCLK and LRCLK edges will occur in a predictable and repeatable position relative to each other and relative to the data for a given combination of DAC sample rate and BCLK_DIV settings.

BCLK_DIV is defined in the “Digital Audio Interface Control” section. See also “Clocking and Sample Rates” section for more information.

AUDIO DATA FORMATS (NORMAL MODE)

In Right Justified mode, the LSB is available on the last rising edge of BCLK before a LRCLK transition. All other bits are transmitted before (MSB first). Depending on word length, BCLK frequency and sample rate, there may be unused BCLK cycles after each LRCLK transition.

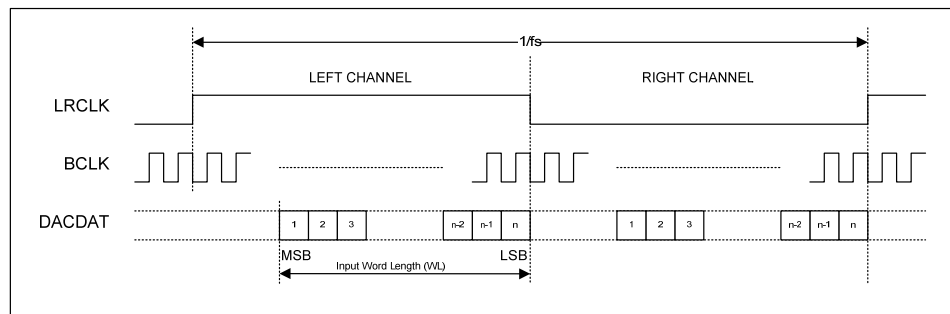

Figure 30 Right Justified Audio Interface (assuming n-bit word length)

In Left Justified mode, the MSB is available on the first rising edge of BCLK following a LRCLK transition. The other bits up to the LSB are then transmitted in order. Depending on word length, BCLK frequency and sample rate, there may be unused BCLK cycles before each LRCLK transition.

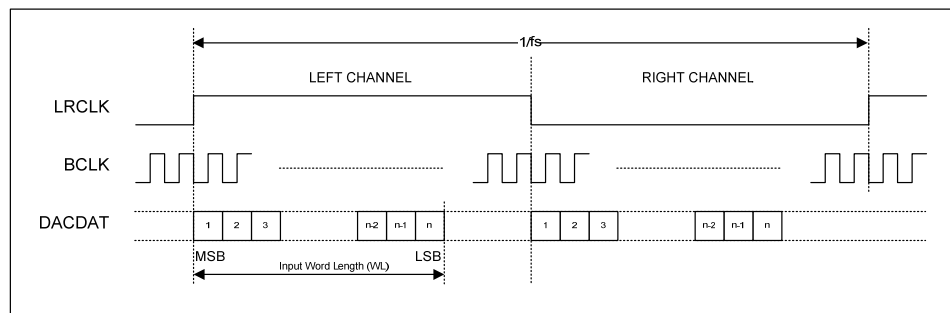

Figure 31 Left Justified Audio Interface (assuming n-bit word length)

In I²S mode, the MSB is available on the second rising edge of BCLK following a LRCLK transition. The other bits up to the LSB are then transmitted in order. Depending on word length, BCLK frequency and sample rate, there may be unused BCLK cycles between the LSB of one sample and the MSB of the next.

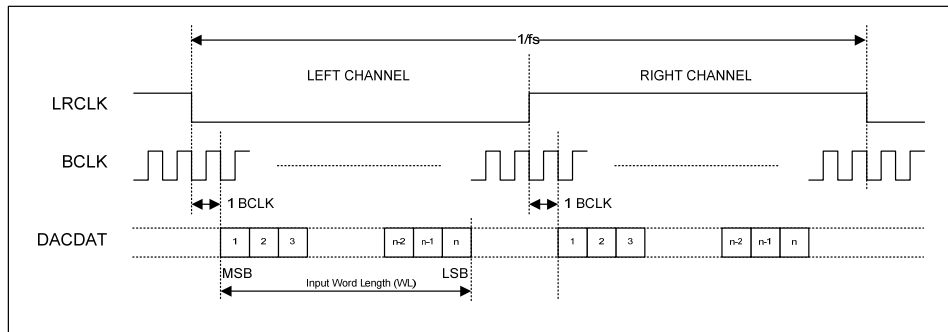

Figure 32 I2S Justified Audio Interface (assuming n-bit word length)

In DSP mode, the left channel MSB is available on either the 1st (mode B) or 2nd (mode A) rising edge of BCLK (selectable by AIF_LRCLK_INV) following a rising edge of LRCLK. Right channel data immediately follows left channel data. Depending on word length, BCLK frequency and sample rate, there may be unused BCLK cycles between the LSB of the right channel data and the next sample.

In device master mode, the LRC output will resemble the frame pulse shown in Figure 33 and Figure 34. In device slave mode, Figure 35 and Figure 36, it is possible to use any length of frame pulse less than 1/fs, providing the falling edge of the frame pulse occurs greater than one BCLK period before the rising edge of the next frame pulse.

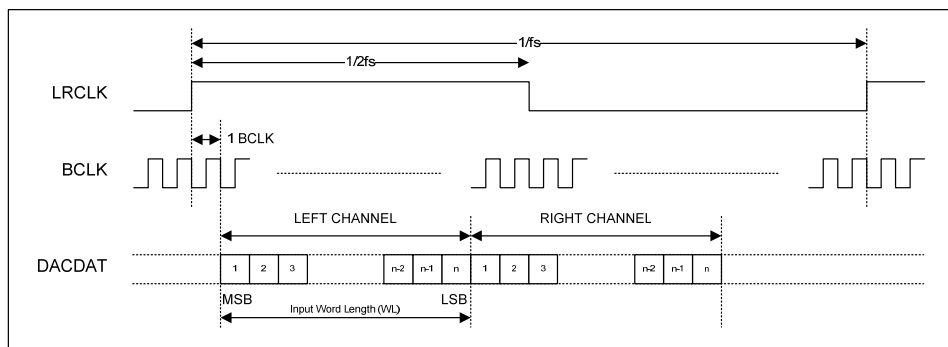

Figure 33 DSP Mode Audio Interface (mode A, AIF_LRCLK_INV=0, Master)

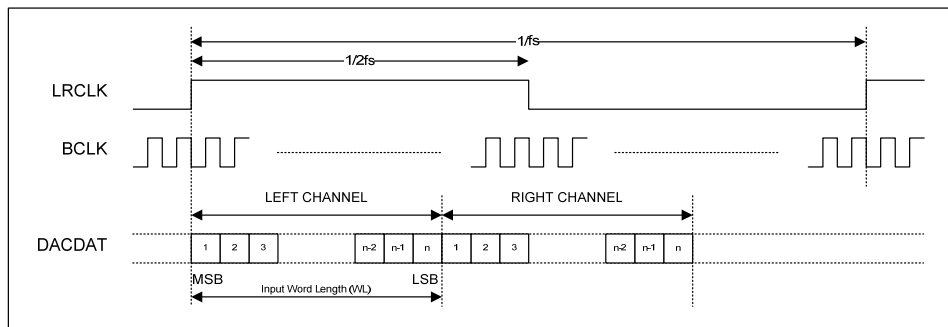

Figure 34 DSP Mode Audio Interface (mode B, AIF_LRCLK_INV=1, Master)

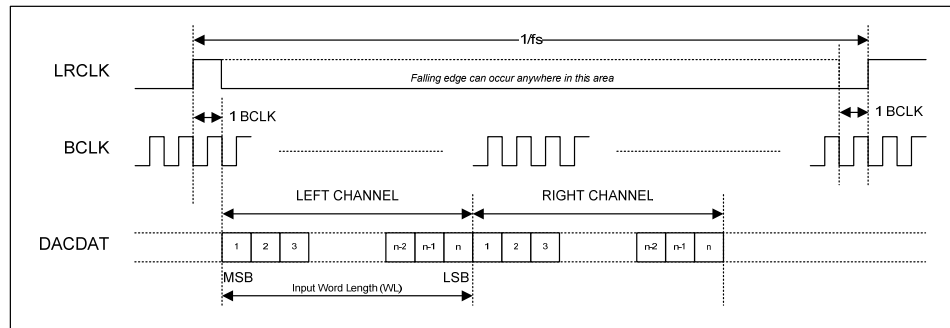

Figure 35 DSP Mode Audio Interface (mode A, AIF_LRCLK_INV=0, Slave)

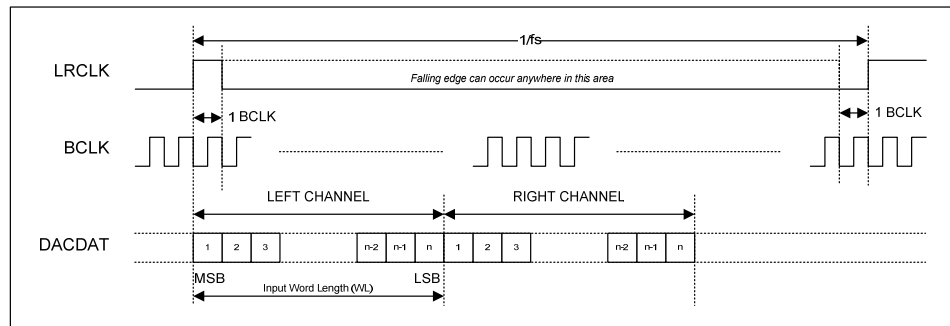

Figure 36 DSP Mode Audio Interface (mode B, AIF_LRCLK_INV=1, Slave)

PCM operation is supported in DSP interface mode. Mono PCM data received by the WM8912 will be treated as Left Channel data. This data may be routed to the Left/Right DACs as described in the "Digital Mixing" section.

AUDIO DATA FORMATS (TDM MODE)

TDM is supported in master and slave mode and is enabled by the AIFDAC_TDM register bit. All audio interface data formats support time division multiplexing (TDM) for DAC data.

Two time slots are available (Slot 0 and Slot 1), selected by the AIFDAC_TDM_CHAN register bit.

When TDM is enabled, BCLK frequency must be high enough to allow data from both time slots to be transferred. The relative timing of Slot 0 and Slot 1 depends upon the selected data format as shown in Figure 37 to Figure 41.

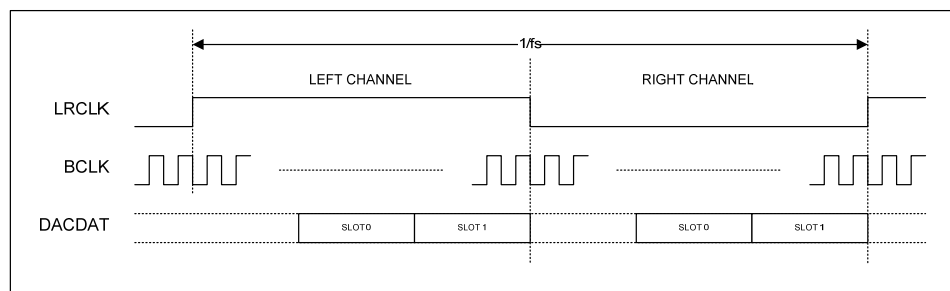

Figure 37 TDM in Right-Justified Mode

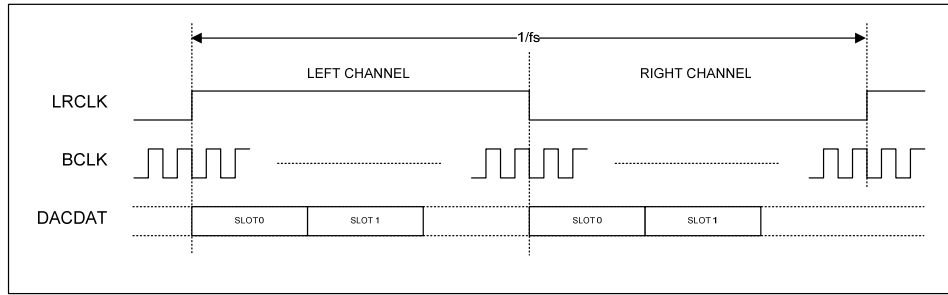

Figure 38 TDM in Left-Justified Mode

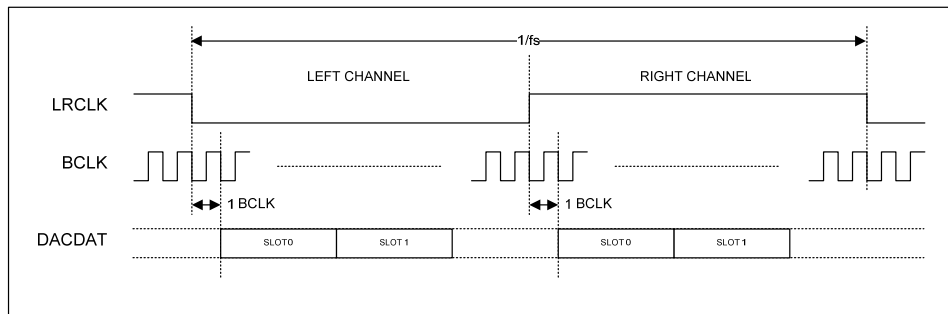

Figure 39 TDM in I²S Mode

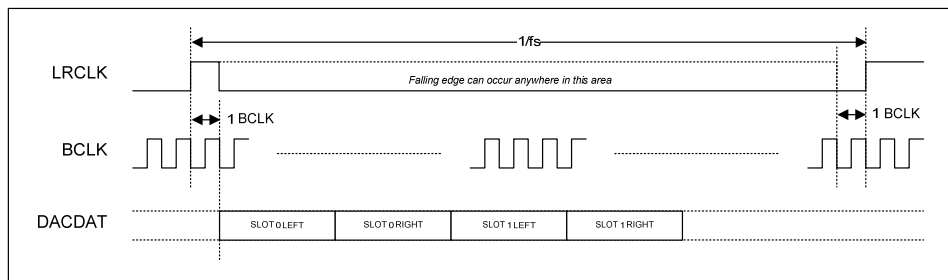

Figure 40 TDM in DSP Mode A

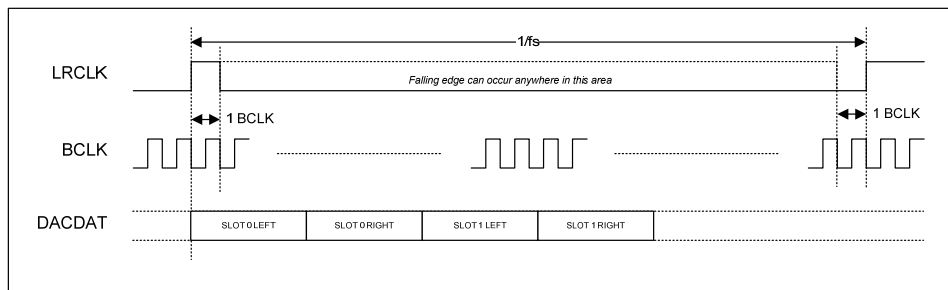

Figure 41 TDM in DSP Mode B

DIGITAL AUDIO INTERFACE CONTROL

The register bits controlling audio data format, word length, left/right channel data source and TDM are summarised in Table 33.

REGISTER ADDRESS	BIT	LABEL	DEFAULT	DESCRIPTION
R24 (18h) Audio Interface 0	5	AIFDACL_SRC	0	Left DAC Data Source Select 0 = Left DAC outputs left channel data 1 = Left DAC outputs right channel data
	4	AIFDACR_SRC	1	Right DAC Data Source Select 0 = Right DAC outputs left channel data 1 = Right DAC outputs right channel data
R25 (19h) Audio Interface 1	13	AIFDAC_TDM	0	DAC TDM Enable 0 = Normal DACDAT operation 1 = TDM enabled on DACDAT
	12	AIFDAC_TDM_CHAN	0	DACDAT TDM Channel Select 0 = DACDAT data input on slot 0 1 = DACDAT data input on slot 1
	7	AIF_BCLK_INV	0	BCLK Invert 0 = BCLK not inverted 1 = BCLK inverted
	4	AIF_LRCLK_INV	0	LRC Polarity / DSP Mode A-B select. Right, left and I2S modes – LRC polarity 0 = Not Inverted 1 = Inverted DSP Mode – Mode A-B select 0 = MSB is available on 2nd BCLK rising edge after LRC rising edge (mode A) 1 = MSB is available on 1st BCLK rising edge after LRC rising edge (mode B)
	3:2	AIF_WL [1:0]	10	Digital Audio Interface Word Length 00 = 16 bits 01 = 20 bits 10 = 24 bits 11 = 32 bits
	1:0	AIF_FMT [1:0]	10	Digital Audio Interface Format 00 = Right Justified 01 = Left Justified 10 = I2S 11 = DSP

Table 33 Digital Audio Interface Data Control

AUDIO INTERFACE OUTPUT TRI-STATE

Register bit AIF_TRIS can be used to tri-state the audio interface pins as described in Table 34. All digital audio interface pins will be tri-stated by this function, regardless of the state of other registers which control these pin configurations.

REGISTER ADDRESS	BIT	LABEL	DEFAULT	DESCRIPTION
R25 (19h) Audio Interface 1	8	AIF_TRIS	0	Audio Interface Tristate 0 = Audio interface pins operate normally 1 = Tristate all audio interface pins

Table 34 Digital Audio Interface Tri-State Control

BCLK AND LRCLK CONTROL

The audio interface can be programmed to operate in master mode or slave mode using the BCLK_DIR and LRCLK_DIR register bits. In master mode, the BCLK and LRCLK signals are generated by the WM8912 when either of the DACs is enabled. In slave mode, the BCLK and LRCLK clock outputs are disabled by default to allow another digital audio interface to drive these pins.

It is also possible to force the BCLK or LRCLK signals to be output using BCLK_DIR and LRCLK_DIR, allowing mixed master and slave modes. The BCLK_DIR and LRCLK_DIR fields are defined in Table 35.

REGISTER ADDRESS	BIT	LABEL	DEFAULT	DESCRIPTION
R25 (19h) Audio Interface 1	6	BCLK_DIR	0	Audio Interface BCLK Direction 0 = BCLK is input 1 = BCLK is output
R26 (1Ah) Audio Interface 2	4:0	BCLK_DIV [4:0]	0_0100	BCLK Frequency (Master Mode) 00000 = SYSCLK 00001 = SYSCLK / 1.5 00010 = SYSCLK / 2 00011 = SYSCLK / 3 00100 = SYSCLK / 4 00101 = SYSCLK / 5 00110 = SYSCLK / 5.5 00111 = SYSCLK / 6 01000 = SYSCLK / 8 (default) 01001 = SYSCLK / 10 01010 = SYSCLK / 11 01011 = SYSCLK / 12 01100 = SYSCLK / 16 01101 = SYSCLK / 20 01110 = SYSCLK / 22 01111 = SYSCLK / 24 10000 = SYSCLK / 25 10001 = SYSCLK / 30 10010 = SYSCLK / 32 10011 = SYSCLK / 44 10100 = SYSCLK / 48
R27 (1Bh) Audio Interface 3	11	LRCLK_DIR	0	Audio Interface LRC Direction 0 = LRC is input 1 = LRC is output
	10:0	LRCLK_RATE [10:0]	000_0100_0000	LRC Rate (Master Mode) LRC clock output = BCLK / LRCLK_RATE Integer (LSB = 1) Valid range: 8 to 2047

Table 35 Digital Audio Interface Clock Control

COMPANDING

The WM8912 supports A-law and μ -law companding on the digital receive (DAC) path as shown in Table 36.

REGISTER ADDRESS	BIT	LABEL	DEFAULT	DESCRIPTION
R24 (18h) Audio Interface 0	1	DAC_COMP	0	DAC Companding Enable 0 = disabled 1 = enabled
	0	DAC_COMPMODE	0	DAC Companding Type 0 = μ -law 1 = A-law

Table 36 Companding Control

Companding involves using a piecewise linear approximation of the following equations (as set out by ITU-T G.711 standard) for data compression:

μ -law (where $\mu=255$ for the U.S. and Japan):

$$F(x) = \ln(1 + \mu|x|) / \ln(1 + \mu) \quad -1 \leq x \leq 1$$

A-law (where $A=87.6$ for Europe):

$$F(x) = A|x| / (1 + \ln A) \quad x \leq 1/A$$

$$F(x) = (1 + \ln A|x|) / (1 + \ln A) \quad 1/A \leq x \leq 1$$

The companded data is also inverted as recommended by the G.711 standard (all 8 bits are inverted for μ -law, all even data bits are inverted for A-law). The data will be transmitted as the first 8 MSBs of data.

Companding converts 13 bits (μ -law) or 12 bits (A-law) to 8 bits using non-linear quantization. This provides greater precision for low amplitude signals than for high amplitude signals, resulting in a greater usable dynamic range than 8 bit linear quantization. The companded signal is an 8-bit word comprising sign (1 bit), exponent (3 bits) and mantissa (4 bits).

8-bit mode is selected whenever DAC_COMP=1. The use of 8-bit data allows samples to be passed using as few as 8 BCLK cycles per LRCLK frame. When using DSP mode B, 8-bit data words may be transferred consecutively every 8 BCLK cycles.

8-bit mode (without Companding) may be enabled by setting DAC_COMPMODE=1 when DAC_COMP=0.

BIT7	BIT [6:4]	BIT [3:0]
SIGN	EXPONENT	MANTISSA

Table 37 8-bit Companded Word Composition

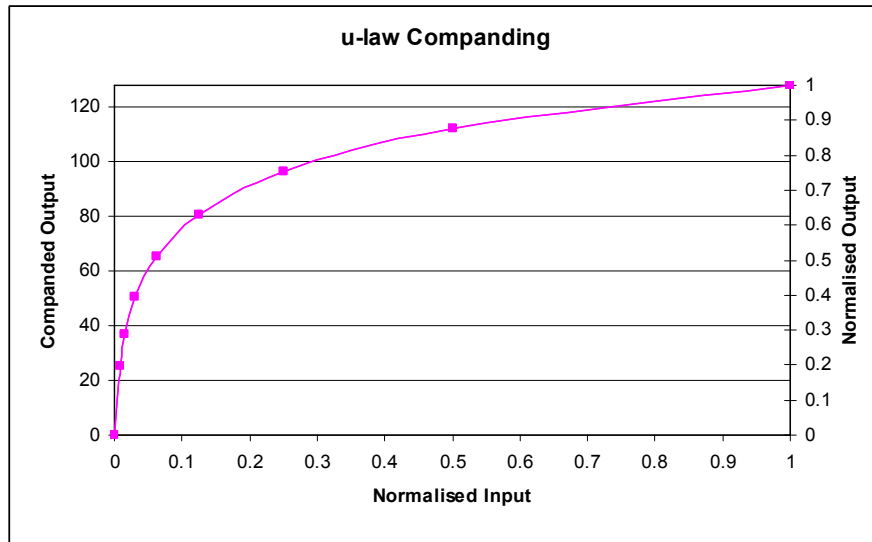

Figure 42 μ -Law Companding

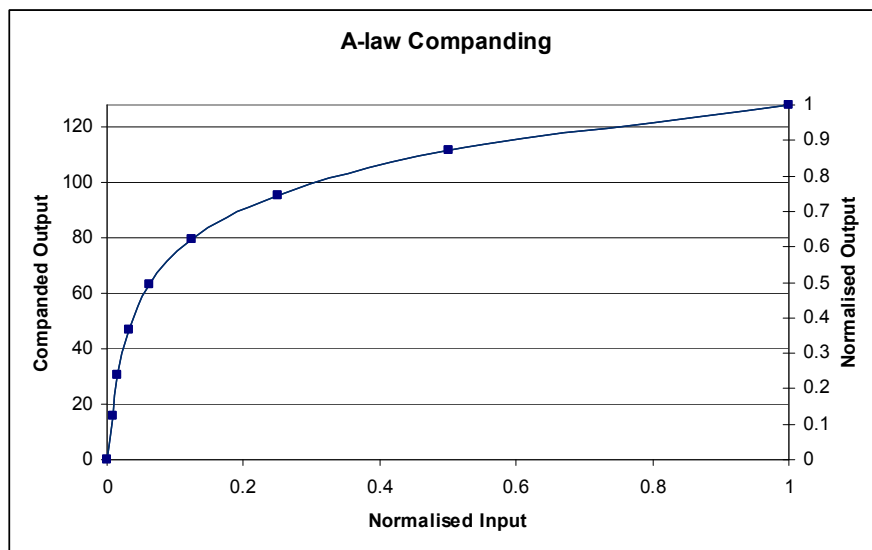

Figure 43 A-Law Companding

DIGITAL PULL-UP AND PULL-DOWN

The WM8912 provides integrated pull-up and pull-down resistors on each of the MCLK, DACDAT, LRCLK and BCLK pins. This provides a flexible capability for interfacing with other devices. Each of the pull-up and pull-down resistors can be configured independently using the register bits described in Table 38.

REGISTER ADDRESS	BIT	LABEL	DEFAULT	DESCRIPTION
R126 (7Eh) Digital Pulls	7	MCLK_PU	0	MCLK pull-up resistor enable 0 = pull-up disabled 1 = pull-up enabled
	6	MCLK_PD	0	MCLK pull-down resistor enable 0 = pull-down disabled 1 = pull-down enabled
	5	DACDAT_PU	0	DACDAT pull-up resistor enable 0 = pull-up disabled 1 = pull-up enabled
	4	DACDAT_PD	0	DACDAT pull-down resistor enable 0 = pull-down disabled 1 = pull-down enabled
	3	LRCLK_PU	0	LRCLK pull-up resistor enable 0 = pull-up disabled 1 = pull-up enabled
	2	LRCLK_PD	0	LRCLK pull-down resistor enable 0 = pull-down disabled 1 = pull-down enabled
	1	BCLK_PU	0	BCLK pull-up resistor enable 0 = pull-up disabled 1 = pull-up enabled
	0	BCLK_PD	0	BCLK pull-down resistor enable 0 = pull-down disabled 1 = pull-down enabled

Table 38 Digital Audio Interface Pull-Up and Pull-Down Control

CLOCKING AND SAMPLE RATES

The internal clocks for the WM8912 are all derived from a common internal clock source, SYSCLK. This clock is the reference for the DACs, DSP core functions, digital audio interface, DC servo control and other internal functions.

SYSCLK can either be derived directly from MCLK, or may be generated from a Frequency Locked Loop (FLL) using MCLK, BCLK or LRCLK as a reference. Many commonly-used audio sample rates can be derived directly from typical MCLK frequencies; the FLL provides additional flexibility for a wide range of MCLK frequencies. To avoid audible glitches, all clock configurations must be set up before enabling playback. The FLL can be used to generate a free-running clock in the absence of an external reference source; see "Frequency Locked Loop" for further details.

The WM8912 supports automatic clocking configuration. The programmable dividers associated with the DACs, DSP core functions and DC servo are configured automatically, with values determined from the CLK_SYS_RATE and SAMPLE_RATE fields. The user must also configure the OPCLK (if required), the TOCLK (if required) and the Digital Audio Interface.

Oversample rates of 64fs or 128fs are supported (based on a 48kHz sample rate).

A 256kHz clock, supporting a number of internal functions, is derived from SYSCLK.

The DC servo control is clocked from SYSCLK.

A GPIO Clock, OPCLK, can be derived from SYSCLK and output on a GPIO pin to provide clocking to other devices. This clock is enabled by OPCLK_ENA and controlled by OPCLK_DIV.

A slow clock, TOCLK, is used to de-bounce the button/accessory detect inputs, and to set the timeout period for volume updates when zero-cross detect is used. This clock is enabled by TOCLK_ENA and controlled by TOCLK_RATE, TOCLK_RATE_X4 and TOCLK_RATE_DIV16.

In master mode, BCLK is derived from SYSCLK via a programmable divider set by BCLK_DIV. In master mode, the LRCLK is derived from BCLK via a programmable divider LRCLK_RATE. The LRCLK can be derived from an internal or external BCLK source, allowing mixed master/slave operation.

The control registers associated with Clocking and Sample Rates are shown in Table 39 to Table 43.

The overall clocking scheme for the WM8912 is illustrated in Figure 44.

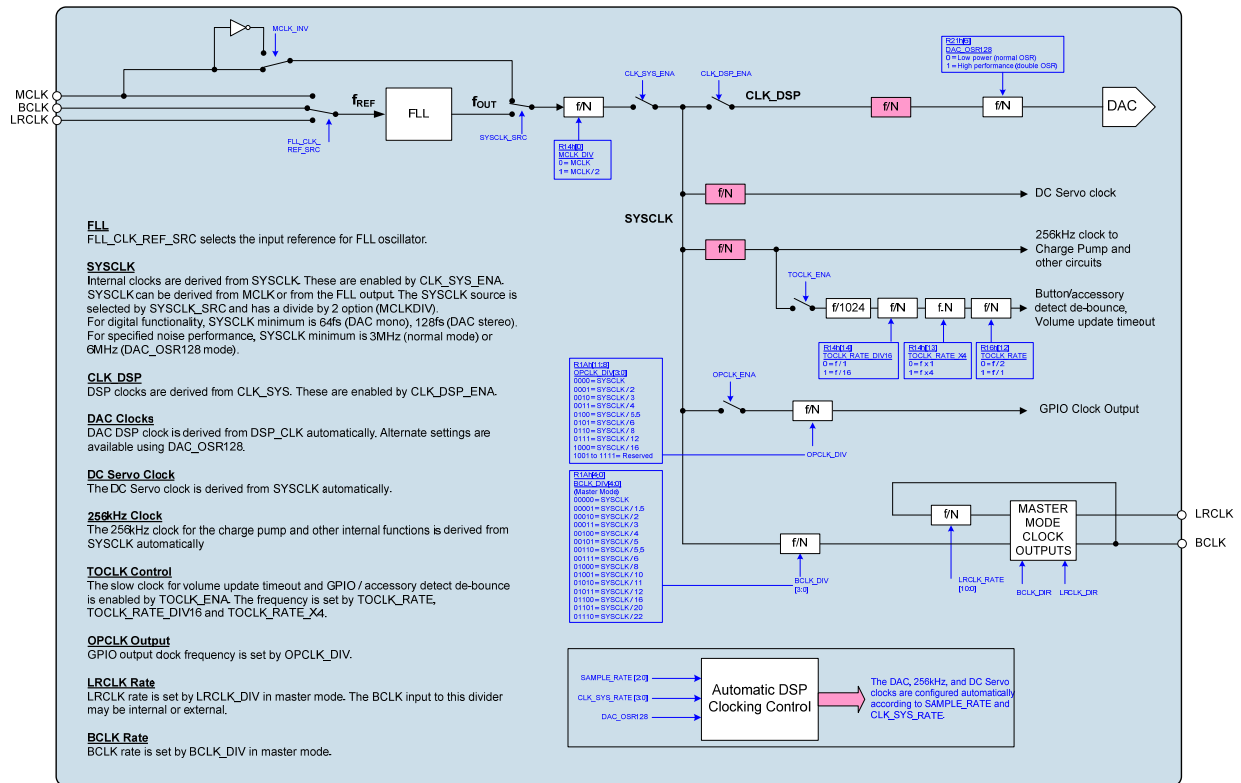

Figure 44 Clocking Scheme

SYSCLK CONTROL

The SYSCLK_SRC bit is used to select the source for SYSCLK. The source may be either the selected MCLK source or the FLL output. The MCLK source can be inverted or non-inverted, as selected by the MCLK_INV bit. The selected source may also be adjusted by the MCLK_DIV divider to generate SYSCLK. These register fields are described in Table 39. See "Frequency Locked Loop (FLL)" for more details of the Frequency Locked Loop clock generator.

The SYSCLK signal is enabled by register bit CLK_SYS_ENA. This bit should be set to 0 when reconfiguring clock sources. It is not recommended to change SYSCLK_SRC while the CLK_SYS_ENA bit is set.

The following operating frequency limits must be observed when configuring SYSCLK. Failure to observe these limits will result in degraded noise performance and/or incorrect DAC functionality.

- SYSCLK ≥ 3MHz
- If DAC_OS128 = 1 then SYSCLK ≥ 6MHz
- If DAC_MONO = 1, then SYSCLK ≥ 64 x fs
- If DAC_MONO = 0, then SYSCLK ≥ 128 x fs

Note that DAC Mono mode (DAC_MONO = 1) is only valid when one or other DAC is disabled. If both DACs are enabled, then the minimum SYSCLK for clocking the DACs is 128 x fs.

The SYSCLK control register fields are defined in Table 39.

REGISTER ADDRESS	BIT	LABEL	DEFAULT	DESCRIPTION
R22 (16h) Clock Rates 2	15	MCLK_INV	0	MCLK Invert 0 = MCLK not inverted 1 = MCLK inverted
	14	SYSCLK_SRC	0	SYSCLK Source Select 0 = MCLK 1 = FLL output
	2	CLK_SYS_ENA	0	System Clock enable 0 = Disabled 1 = Enabled
R20 (14h) Clock Rates 0	0	MCLK_DIV	0	Enables divide by 2 on MCLK 0 = SYSCLK = MCLK 1 = SYSCLK = MCLK / 2

Table 39 MCLK and SYSCLK Control

CONTROL INTERFACE CLOCKING

Register map access is possible with or without a Master Clock (MCLK). However, if CLK_SYS_ENA has been set to 1, then a Master Clock must be present for control register Read/Write operations. If CLK_SYS_ENA = 1 and MCLK is not present, then register access will be unsuccessful. (Note that read/write access to register R22, containing CLK_SYS_ENA, is always possible.)

If it cannot be assured that MCLK is present when accessing the register map, then it is required to set CLK_SYS_ENA = 0 to ensure correct operation.

Note that MCLK is always required when using HPOUTL, HPOUTR, LINEOUTL or LINEOUTR.

CLOCKING CONFIGURATION

The WM8912 supports a wide range of standard audio sample rates from 8kHz to 96kHz. The Automatic Clocking Configuration simplifies the configuration of the clock dividers in the WM8912 by deriving most of the required parameters from a minimum number of user registers.

The SAMPLE_RATE field selects the sample rate, fs, of the DAC.

The CLK_SYS_RATE fields must be set according to the ratio of SYSCLK to fs. When these fields are set correctly, the Sample Rate Decoder circuit automatically determines the clocking configuration for all other circuits within the WM8912.

A high performance mode of DAC operation can be selected by setting the DAC_OSR128 bit; in 48kHz sample mode, the DAC_OSR128 feature results in 128x oversampling. Audio performance is improved, but power consumption is also increased.

REGISTER ADDRESS	BIT	LABEL	DEFAULT	DESCRIPTION
R33 (21h) DAC Digital 1	6	DAC_OS128	0	DAC Oversample Rate Select 0 = Low power (normal OSR) 1 = High performance (double OSR)
R21 (15h) Clock Rates 1	13:10	CLK_SYS_RATE [3:0]	0011	Selects the SYSCLK / fs ratio 0000 = 64 0001 = 128 0010 = 192 0011 = 256 0100 = 384 0101 = 512 0110 = 768 0111 = 1024 1000 = 1408 1001 = 1536
	2:0	SAMPLE_RATE [2:0]	101	Selects the Sample Rate (fs) 000 = 8kHz 001 = 11.025kHz, 12kHz 010 = 16kHz 011 = 22.05kHz, 24kHz 100 = 32kHz 101 = 44.1kHz, 48kHz 110 to 111 = Reserved

Table 40 Automatic Clocking Configuration Control

DAC CLOCK CONTROL

The clocking of the DAC circuits is derived from CLK_DSP, which is enabled by CLK_DSP_ENA. CLK_DSP is generated from SYSCLK which is separately enabled, using the register bit CLK_SYS_ENA.

Note that higher performance DAC operation can be achieved by increasing the DAC oversample rate - see Table 40.

REGISTER ADDRESS	BIT	LABEL	DEFAULT	DESCRIPTION
R22 (16h) Clock Rates 2	1	CLK_DSP_ENA	0	DSP Clock enable 0 = Disabled 1 = Enabled

Table 41 ADC / DAC Clock Control

OPCLK CONTROL

A clock output (OPCLK) derived from SYSCLK may be output on a GPIO pin. This clock is enabled by register bit OPCLK_ENA, and its frequency is controlled by OPCLK_DIV.

This output of this clock is also dependent upon the GPIO register settings described under "General Purpose Input/Output (GPIO)".

REGISTER ADDRESS	BIT	LABEL	DEFAULT	DESCRIPTION
R22 (16h) Clock Rates 2	3	OPCLK_ENA	0	GPIO Clock Output Enable 0 = disabled 1 = enabled
R26 (1Ah) Audio Interface 2	11:8	OPCLK_DIV [3:0]	0000	GPIO Output Clock Divider 0000 = SYSCLK 0001 = SYSCLK / 2 0010 = SYSCLK / 3 0011 = SYSCLK / 4 0100 = SYSCLK / 5.5 0101 = SYSCLK / 6 0110 = SYSCLK / 8 0111 = SYSCLK / 12 1000 = SYSCLK / 16 1001 to 1111 = Reserved

Table 42 OPCLK Control

TOCLK CONTROL

A slow clock (TOCLK) is derived from the internally generated 256kHz clock to enable input debouncing and volume update timeout functions. This clock is enabled by register bit TOCLK_ENA, and its frequency is controlled by TOCLK_RATE and TOCLK_RATE_X4, as described in Table 43.

REGISTER ADDRESS	BIT	LABEL	DEFAULT	DESCRIPTION
R22 (16h) Clock Rates 2	12	TOCLK_RATE	0	TOCLK Rate Divider (/2) 0 = f / 2 1 = f / 1
	0	TOCLK_ENA	0	Zero Cross timeout enable 0 = Disabled 1 = Enabled
R20 (14h) Clock Rates 0	14	TOCLK_RATE_DIV16	0	TOCLK Rate Divider (/16) 0 = f / 1 1 = f / 16
	13	TOCLK_RATE_X4	0	TOCLK Rate Multiplier 0 = f x 1 1 = f x 4

Table 43 TOCLK Control

A list of possible TOCLK rates is provided in Table 44.

TOCLK_RATE	TOCLK_RATE_X4	TOCLK_RATE_DIV16	TOCLK	
			FREQ (Hz)	PERIOD (ms)
1	1	0	1000	1
0	1	0	500	2
1	0	0	250	4
0	0	0	125	8
1	1	1	62.5	16
0	1	1	31.25	32
1	0	1	15.625	64
0	0	1	7.8125	128

Table 44 TOCLK Rates

DAC OPERATION AT 88.2K / 96K

The WM8912 supports DAC operation at 88.2kHz and 96kHz sample rates. This section details specific conditions applicable to these operating modes.

For DAC operation at 88.2kHz or 96kHz sample rates, the available clocking configurations are detailed in Table 45. DAC operation at these sample rates is achieved by setting the SAMPLE_RATE field to half the required sample rate (eg. select 48kHz for 96kHz mode).

For DAC operation at 88.2kHz or 96kHz sample rates, the DAC_OSR128 register must be set to 0. ReTune™ Mobile can not be used during 88.2kHz or 96kHz operation, so EQ_ENA must be set to 0.

The SYSCLK frequency is derived from MCLK. The maximum MCLK frequency is defined in the "Signal Timing Requirements" section.

SAMPLE RATE	REGISTER CONFIGURATION	CLOCKING RATIO
88.2kHz	SAMPLE_RATE = 101 CLK_SYS_RATE = 0001 (SYSCLK / fs = 128) BCLK_DIV = 00010 LRCLK_RATE = 040h	SYSCLK = 128 x fs
96kHz	SAMPLE_RATE = 101 CLK_SYS_RATE = 0001 (SYSCLK / fs = 128) BCLK_DIV = 00010 LRCLK_RATE = 040h	SYSCLK = 128 x fs

Table 45 DAC Operation at 88.2kHz and 96kHz Sample Rates

FREQUENCY LOCKED LOOP (FLL)

The integrated FLL can be used to generate SYSCLK from a wide variety of different reference sources and frequencies. The FLL can use either MCLK, BCLK or LRCLK as its reference, which may be a high frequency (eg. 12.288MHz) or low frequency (eg. 32,768kHz) reference. The FLL is tolerant of jitter and may be used to generate a stable SYSCLK from a less stable input signal. The FLL characteristics are summarised in “Electrical Characteristics”.

Note that the FLL can be used to generate a free-running clock in the absence of an external reference source. This is described in the “Free-Running FLL Clock” section below.

The FLL is enabled using the FLL_ENA register bit. Note that, when changing FLL settings, it is recommended that the digital circuit be disabled via FLL_ENA and then re-enabled after the other register settings have been updated. When changing the input reference frequency F_{REF} , it is recommended the FLL be reset by setting FLL_ENA to 0.

The FLL_CLK_REF_SRC field allows MCLK, BCLK or LRCLK to be selected as the input reference clock.

The field FLL_CLK_REF_DIV provides the option to divide the input reference (MCLK, BCLK or LRCLK) by 1, 2, 4 or 8. This field should be set to bring the reference down to 13.5MHz or below. For best performance, it is recommended that the highest possible frequency - within the 13.5MHz limit - should be selected.

The field FLL_CTRL_RATE controls internal functions within the FLL; it is recommended that only the default setting be used for this parameter. FLL_GAIN controls the internal loop gain and should be set to the recommended value quoted in Table 48.

The FLL output frequency is directly determined from FLL_FRATIO, FLL_OUTDIV and the real number represented by FLL_N and FLL_K. The field FLL_N is an integer (LSB = 1); FLL_K is the fractional portion of the number (MSB = 0.5). The fractional portion is only valid when enabled by the field FLL_FRACN_ENA.

It is recommended that FLL_FRACN_ENA is enabled at all times. Power consumption in the FLL is reduced in integer mode; however, the performance may also be reduced, with increased noise or jitter on the output.

If low power consumption is required, then FLL settings must be chosen when N.K is an integer (ie. FLL_K = 0). In this case, the fractional mode can be disabled by setting FLL_FRACN_ENA = 0.

For best FLL performance, a non-integer value of N.K is required. In this case, the fractional mode must be enabled by setting FLL_FRACN_ENA = 1. The FLL settings must be adjusted, if necessary, to produce a non-integer value of N.K.

The FLL output frequency is generated according to the following equation:

$$F_{OUT} = (F_{VCO} / FLL_OUTDIV)$$

The FLL operating frequency, F_{VCO} is set according to the following equation:

$$F_{VCO} = (F_{REF} \times N.K \times FLL_FRATIO)$$

See Table 48 for the coding of the FLL_OUTDIV and FLL_FRATIO fields.

F_{REF} is the input frequency, as determined by FLL_CLK_REF_DIV.

F_{VCO} must be in the range 90-100 MHz. Frequencies outside this range cannot be supported.

Note that the output frequencies that do not lie within the ranges quoted above cannot be guaranteed across the full range of device operating temperatures.

In order to follow the above requirements for F_{VCO} , the value of FLL_OUTDIV should be selected according to the desired output F_{OUT} . The divider, FLL_OUTDIV, must be set so that F_{VCO} is in the range 90-100MHz. The available divisions are integers from 4 to 64. Some typical settings of FLL_OUTDIV are noted in Table 46.

OUTPUT FREQUENCY F_{OUT}	FLL_OUTDIV
2.8125 MHz - 3.125 MHz	011111 (divide by 32)
3.75 MHz - 4.1667 MHz	011000 (divide by 24)
5.625 MHz - 6.25 MHz	001111 (divide by 16)
11.25 MHz - 12.5 MHz	000111 (divide by 8)
18 MHz - 20 MHz	000100 (divide by 5)
22.5 MHz - 25 MHz	000011 (divide by 4)

Table 46 Selection of FLL_OUTDIV

The value of FLL_FRATIO should be selected as described in Table 47.

REFERENCE FREQUENCY F_{REF}	FLL_FRATIO
1MHz - 13.5MHz	0h (divide by 1)
256kHz - 1MHz	1h (divide by 2)
128kHz - 256kHz	2h (divide by 4)
64kHz - 128kHz	3h (divide by 8)
Less than 64kHz	4h (divide by 16)

Table 47 Selection of FLL_FRATIO

In order to determine the remaining FLL parameters, the FLL operating frequency, F_{VCO} , must be calculated, as given by the following equation:

$$F_{VCO} = (F_{OUT} \times FLL_OUTDIV)$$

The value of FLL_N and FLL_K can then be determined as follows:

$$N.K = F_{VCO} / (FLL_FRATIO \times F_{REF})$$

See Table 48 for the coding of the FLL_OUTDIV and FLL_FRATIO fields.

Note that F_{REF} is the input frequency, after division by FLL_CLK_REF_DIV, where applicable.

In FLL Fractional Mode, the fractional portion of the N.K multiplier is held in the FLL_K register field. This field is coded as a fixed point quantity, where the MSB has a weighting of 0.5. Note that, if desired, the value of this field may be calculated by multiplying K by 2^{16} and treating FLL_K as an integer value, as illustrated in the following example:

$$\text{If } N.K = 8.192, \text{ then } K = 0.192$$

$$\text{Multiplying } K \text{ by } 2^{16} \text{ gives } 0.192 \times 65536 = 12582.912 \text{ (decimal)}$$

$$\text{Apply rounding to the nearest integer} = 12583 \text{ (decimal)} = 3127 \text{ (hex)}$$

For best performance, FLL Fractional Mode should always be used. Therefore, if the calculations yield an integer value of N.K, then it is recommended to adjust FLL_OUTDIV in order to obtain a non-integer value of N.K. Care must always be taken to ensure that the FLL operating frequency, F_{VCO} , is within its recommended limits of 90-100 MHz.

The register fields that control the FLL are described in Table 48. Example settings for a variety of reference frequencies and output frequencies are shown in Table 50.

REGISTER ADDRESS	BIT	LABEL	DEFAULT	DESCRIPTION
R116 (74h) FLL Control 1	2	FLL_FRACN_ENA	0	FLL Fractional enable 0 = Integer Mode 1 = Fractional Mode Fractional Mode (FLL_FRACN_ENA=1) is recommended in all cases
	1	FLL_OSC_ENA	0	FLL Oscillator enable 0 = Disabled 1 = Enabled FLL_OSC_ENA must be enabled before enabling FLL_ENA. Note that this field is required for free-running FLL modes only.
	0	FLL_ENA	0	FLL Enable 0 = Disabled 1 = Enabled FLL_OSC_ENA must be enabled before enabling FLL_ENA.
R117 (75h) FLL Control 2	13:8	FLL_OUTDIV [5:0]	00_0000	FLL FOUT clock divider 00_0000 = Reserved 00_0001 = Reserved 00_0010 = Reserved 00_0011 = 4 00_0100 = 5 00_0101 = 6 ... 11_1110 = 63 11_1111 = 64 (FOUT = FVCO / FLL_OUTDIV)
	6:4	FLL_CTRL_RATE [2:0]	000	Frequency of the FLL control block 000 = FVCO / 1 (Recommended value) 001 = FVCO / 2 010 = FVCO / 3 011 = FVCO / 4 100 = FVCO / 5 101 = FVCO / 6 110 = FVCO / 7 111 = FVCO / 8 Recommended that these are not changed from default.

REGISTER ADDRESS	BIT	LABEL	DEFAULT	DESCRIPTION
	2:0	FLL_FRATIO [2:0]	111	FVCO clock divider 000 = 1 001 = 2 010 = 4 011 = 8 1XX = 16 000 recommended for high FREF 011 recommended for low FREF
R118 (76h) FLL Control 3	15:0	FLL_K [15:0]	0000h	Fractional multiply for F _{REF} (MSB = 0.5)
R119 (77h) FLL Control 4	14:5	FLL_N [9:0]	177h	Integer multiply for F _{REF} (LSB = 1)
	3:0	FLL_GAIN [3:0]	0h	Gain applied to error 0000 = x 1 (Recommended value) 0001 = x 2 0010 = x 4 0011 = x 8 0100 = x 16 0101 = x 32 0110 = x 64 0111 = x 128 1000 = x 256 Recommended that these are not changed from default.
R120 (78h) FLL Control 5	4:3	FLL_CLK_REF_DIV [1:0]	00	FLL Clock Reference Divider 00 = MCLK / 1 01 = MCLK / 2 10 = MCLK / 4 11 = MCLK / 8 MCLK (or other input reference) must be divided down to <=13.5MHz. For lower power operation, the reference clock can be divided down further if desired.
	1:0	FLL_CLK_REF_SRC [1:0]	00	FLL Clock source 00 = MCLK 01 = BCLK 10 = LRCLK 11 = Reserved

Table 48 FLL Register Map

FREE-RUNNING FLL CLOCK

The FLL can generate a clock signal even when no external reference is available. However, it should be noted that the accuracy of this clock is reduced, and a reference source should always be used where possible. Note that, in free-running mode, the FLL is not sufficiently accurate for hi-fi DAC applications. However, the free-running mode is suitable for clocking most other functions, including the Write Sequencer, Charge Pump, DC Servo and Class W output driver.

If an accurate reference clock is available at FLL start-up, then the FLL should be configured as described above. The FLL will continue to generate a stable output clock after the reference input is stopped or disconnected.

If no reference clock is available at the time of starting up the FLL, then an internal clock frequency of approximately 12MHz can be generated by enabling the FLL Analogue Oscillator using the FLL_OSC_ENA register bit, and setting F_{OUT} clock divider to divide by 8 (FLL_OUTDIV = 07h), as defined in Table 48. Under recommended operating conditions, the FLL output may be forced to approximately 12MHz by then enabling the FLL_FRC_NCO bit and setting FLL_FRC_NCO_VAL to 19h (see Table 49). The resultant SYSCLK delivers the required clock frequencies for the Class W output driver, DC Servo, Charge Pump and other functions. Note that the value of FLL_FRC_NCO_VAL may be adjusted to control F_{OUT}, but care should be taken to maintain the correct relationship between SYSCLK and the aforementioned functional blocks.

REGISTER ADDRESS	BIT	LABEL	DEFAULT	DESCRIPTION
R248 (F8h) FLL NCO Test 1	5:0	FLL_FRC_NCO_VAL [5:0]	01_1001	FLL Forced oscillator value Valid range is 000000 to 111111 0x19h (011001) = 12MHz approx (Note that this field is required for free-running FLL modes only)
R247 (F7h) FLL NCO Test 0	0	FLL_FRC_NCO	0	FLL Forced control select 0 = Normal 1 = FLL oscillator controlled by FLL_FRC_NCO_VAL (Note that this field is required for free-running FLL modes only)

Table 49 FLL Free-Running Mode

In both cases described above, the FLL must be selected as the SYSCLK source by setting SYSCLK_SRC (see Table 39). Note that, in the absence of any reference clock, the FLL output is subject to a very wide tolerance. See "Electrical Characteristics" for details of the FLL accuracy.

EXAMPLE FLL CALCULATION

To generate 12.288 MHz output (F_{OUT}) from a 12.000 MHz reference clock (F_{REF}):

- Set FLL_CLK_REF_DIV in order to generate F_{REF} ≤ 13.5MHz:
FLL_CLK_REF_DIV = 00 (divide by 1)
- Set FLL_CTRL_RATE to the recommended setting:
FLL_CTRL_RATE = 000 (divide by 1)
- Set FLL_GAIN to the recommended setting:
FLL_GAIN = 0000 (multiply by 1)
- Set FLL_OUTDIV for the required output frequency as shown in Table 46:-
F_{OUT} = 12.288 MHz, therefore FLL_OUTDIV = 07h (divide by 8)
- Set FLL_FRATIO for the given reference frequency as shown in Table 47:
F_{REF} = 12MHz, therefore FLL_FRATIO = 0h (divide by 1)
- Calculate F_{VCO} as given by F_{VCO} = F_{OUT} × FLL_OUTDIV:-
F_{VCO} = 12.288 × 8 = 98.304MHz
- Calculate N.K as given by N.K = F_{VCO} / (FLL_FRATIO × F_{REF}):
N.K = 98.304 / (1 × 12) = 8.192
- Determine FLL_N and FLL_K from the integer and fractional portions of N.K:-
FLL_N is 8. FLL_K is 0.192
- Confirm that N.K is a fractional quantity and set FLL_FRACN_ENA:
N.K is fractional. Set FLL_FRACN_ENA = 1.
Note that, if N.K is an integer, then an alternative value of FLL_FRATIO should be selected in order to produce a fractional value of N.K.

GPIO OUTPUTS FROM FLL

The WM8912 has an internal signal which indicates whether the FLL Lock has been achieved. The FLL Lock status is an input to the Interrupt control circuit and can be used to trigger an Interrupt event - see "Interrupts".

The FLL Lock signal can be output directly on a GPIO pin as an external indication of FLL Lock. See "General Purpose Input/Output (GPIO)" for details of how to configure a GPIO pin to output the FLL Lock signal.

The FLL Clock can be output directly on a GPIO pin as a clock signal for other circuits. Note that the FLL Clock may be output even if the FLL is not selected as the WM8912 SYSCCLK source. The clocking configuration is illustrated in Figure 44. See "General Purpose Input/Output (GPIO)" for details of how to configure a GPIO pin to output the FLL Clock.

EXAMPLE FLL SETTINGS

Table 50 provides example FLL settings for generating common SYSCCLK frequencies from a variety of low and high frequency reference inputs.

F _{REF}	F _{OUT}	FLL_CLK_REF_DIV	F _{VCO}	FLL_N	FLL_K	FLL_FRATIO	FLL_OUTDIV	FLL_FRACN_ENA
32.768 kHz	12.288 MHz	Divide by 1 (0h)	98.304 MHz	187 (0BBh)	0.5 (8000h)	16 (4h)	8 (7h)	1
32.768 kHz	11.288576 MHz	Divide by 1 (0h)	90.308608 MHz	344 (158h)	0.5 (8000h)	8 (3h)	8 (7h)	1
32.768 kHz	11.2896 MHz	Divide by 1 (0h)	90.3168 MHz	344 (158h)	0.53125 (8800h)	8 (3h)	8 (7h)	1
48 kHz	12.288 MHz	Divide by 1 (0h)	98.304 MHz	256 (100h)	0 (0000h)	8 (3h)	8 (7h)	0
12.000 MHz	12.288 MHz	Divide by 1 (0h)	98.3040 MHz	8 (008h)	0.192 (3127h)	1 (0h)	8 (7h)	1
12.000 MHz	11.289597 MHz	Divide by 1 (0h)	90.3168 MHz	7 (007h)	0.526398 (86C2h)	1 (0h)	8 (7h)	1
12.288 MHz	12.288 MHz	Divide by 1 (0h)	98.304 MHz	8 (008h)	0 (0000h)	1 (0h)	8 (7h)	0
12.288 MHz	11.2896 MHz	Divide by 1 (0h)	90.3168 MHz	7 (007h)	0.35 (599Ah)	1 (0h)	8 (7h)	1
13.000 MHz	12.287990 MHz	Divide by 1 (0h)	98.3040 MHz	7 (007h)	0.56184 (8FD5h)	1 (0h)	8 (7h)	1
13.000 MHz	11.289606 MHz	Divide by 1 (0h)	90.3168 MHz	6 (006h)	0.94745 (F28Ch)	1 (0h)	8 (7h)	1
19.200 MHz	12.287988 MHz	Divide by 2 (1h)	98.3039 MHz	5 (005h)	0.119995 (1EB8h)	1 (0h)	8 (7h)	1
19.200 MHz	11.289588 MHz	Divide by 2 (1h)	90.3168 MHz	4 (004h)	0.703995 (B439h)	1 (0h)	8 (7h)	1

Table 50 Example FLL Settings

GENERAL PURPOSE INPUT/OUTPUT (GPIO)

The WM8912 provides two multi-function pins which can be configured to provide a number of different functions. These are digital input/output pins on the DBVDD power domain. The GPIO pins are:

- IRQ/GPIO1
- BCLK/GPIO4

Each general purpose I/O pin can be configured to be a GPIO input or configured as one of a number of output functions. Signal de-bouncing can be selected on GPIO input pins for use with jack/button detect applications. Table 51 lists the functions that are available on each of the GPIO pins.

GPIO PIN FUNCTION	GPIO PINS	
	IRQ / GPIO1	BCLK / GPIO4
GPIO input (including jack/button detect)	Yes	Yes
GPIO output	Yes	Yes
BCLK	No	Yes
Interrupt (IRQ)	Yes	Yes
FLL Lock output	Yes	Yes
FLL Clock output	Yes	Yes

Table 51 GPIO Functions

IRQ/GPIO1

The IRQ/GPIO1 pin is configured using the register bits described in Table 52. By default, this pin is IRQ output with pull-down resistor enabled.

REGISTER ADDRESS	BIT	LABEL	DEFAULT	DESCRIPTION
R121 (79h) GPIO Control 1	5	GPIO1_PU	0	GPIO1 pull-up resistor enable 0 = pull-up disabled 1 = pull-up enabled
	4	GPIO1_PD	1	GPIO1 pull-down resistor enable 0 = pull-down disabled 1 = pull-down enabled
	3:0	GPIO1_SEL [3:0]	0100	GPIO1 Function Select 0000 = GPIO input 0001 = Clock output (f=SYSCLK/OPCLKDIV) 0010 = Logic '0' output 0011 = Logic '1' output 0100 = IRQ output (default) 0101 = FLL Lock output 0110 = Reserved 0111 = Reserved 1000 = Reserved 1001 = FLL Clock output 1010 to 1111 = Reserved

Table 52 IRQ/GPIO1 Control

BCLK/GPIO4

The BCLK/GPIO4 pin is configured using the register bits described in Table 53. By default, this pin provides the BCLK function associated with the Digital Audio Interface. The BCLK function can operate in slave mode (BCLK input) or in master mode (BCLK output), depending on the BCLK_DIR register bit as described in the "Digital Audio Interface" section.

It is possible to configure the BCLK/GPIO4 pin to provide various GPIO functions; in this case, the BCLK function is provided using the MCLK pin. Note that the BCLK function is always in slave mode (BCLK input) in this mode.

To select the GPIO4 functions, it is required to set BCLK_DIR = 0 (see Table 35) and to set GPIO_BCLK_MODE_ENA = 1 (see Table 53 below). In this configuration, the MCLK input is used as the bit-clock (BCLK) for the Digital Audio Interface.

When the BCLK/GPIO4 pin is configured as GPIO4, then the pin function is determined by the GPIO_BCLK_SEL register field.

REGISTER ADDRESS	BIT	LABEL	DEFAULT	DESCRIPTION
R124 (7Ch) GPIO Control 4	7	GPIO_BCLK_MODE_ENA	0	Selects BCLK/GPIO4 pin function 0 = BCLK/GPIO4 is used as BCLK 1 = BCLK/GPIO4 is used as GPIO. MCLK provides the BCLK in the AIF in this mode.
	3:0	GPIO_BCLK_SEL [3:0]	0000	BCLK/GPIO4 function select: 0000 = GPIO input (default) 0001 = Clock output (f=SYSCLK/OPCLKDIV) 0010 = Logic '0' output 0011 = Logic '1' output 0100 = IRQ output 0101 = FLL Lock output 0110 = Reserved 0111 = Reserved 1000 = Reserved 1001 = FLL Clock output 1010 to 1111 = Reserved

Table 53 BCLK/GPIO4 Control

INTERRUPTS

The Interrupt Controller has multiple inputs; these include the GPIO input pins and other internal signals. Any combination of these inputs can be used to trigger an Interrupt Output (IRQ) event.

WM8912 interrupt events may be triggered in response to external GPIO inputs, FLL Lock status or Write Sequencer status. Note that the GPIO inputs are only supported as interrupt events when the respective pin is configured as a GPIO input.

There is an Interrupt Status field associated with each of the IRQ inputs. These are contained in the Interrupt Status Register (R127), as described in Table 54. The status of the IRQ inputs can be read from this register at any time, or in response to the Interrupt Output being signalled via a GPIO pin.

Individual mask bits can select or deselect different functions from the Interrupt controller. These are listed within the Interrupt Status Mask register (R128), as described in Table 54. Note that the Interrupt Status fields remain valid, even when masked, but the masked bits will not cause the Interrupt (IRQ) output to be asserted.

The Interrupt (IRQ) output represents the logical 'OR' of all unmasked IRQ inputs. The bits within the Interrupt Status register (R127) are latching fields and, once set, are not reset until a '1' is written to the respective register bit in the Interrupt Status Register. The Interrupt (IRQ) output is not reset until each of the unmasked IRQ inputs has been reset.

Each of the IRQ inputs can be individually inverted in the Interrupt function, enabling either active high or active low behaviour on each IRQ input. The polarity inversion is controlled using the bits contained in the Interrupt Polarity register (R129).

Each of the IRQ inputs can be debounced to ensure that spikes and transient glitches do not assert the Interrupt Output. This is selected using the bits contained in the Interrupt Debounce Register (R130).

The WM8912 Interrupt Controller circuit is illustrated in Figure 45. The associated control fields are described in Table 54.

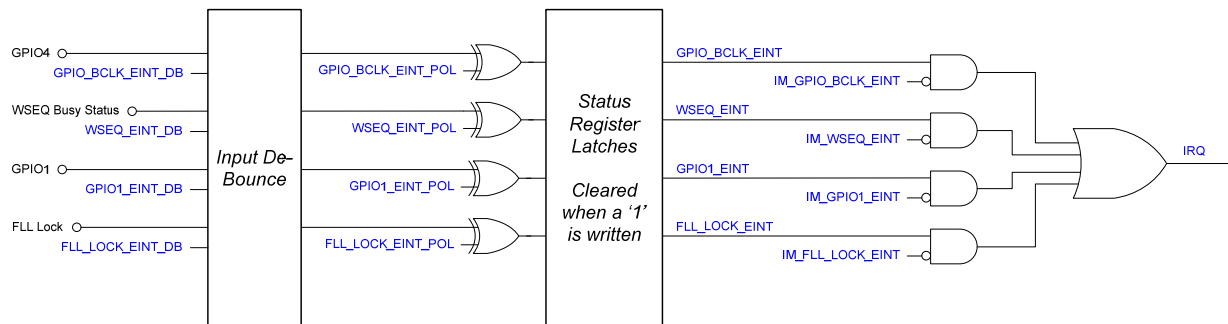

Figure 45 Interrupt Controller

REGISTER ADDRESS	BIT	LABEL	DEFAULT	DESCRIPTION
R127 (7Fh) Interrupt Status	10	IRQ	0	Logical OR of all other interrupt flags
	9	GPIO_BCLK_EINT	0	GPIO4 interrupt 0 = interrupt not set 1 = interrupt is set Cleared when a '1' is written
	8	WSEQ_EINT	0	Write Sequence interrupt 0 = interrupt not set 1 = interrupt is set Cleared when a '1' is written. Note that the read value of WSEQ_EINT is not valid whilst the Write Sequencer is Busy
	5	GPIO1_EINT	0	GPIO1 interrupt 0 = interrupt not set 1 = interrupt is set Cleared when a '1' is written
	2	FLL_LOCK_EINT	0	FLL Lock interrupt 0 = interrupt not set 1 = interrupt is set Cleared when a '1' is written
R128 (80h) Interrupt Status Mask	9	IM_GPIO_BCLK_EINT	1	GPIO4 interrupt mask 0 = do not mask interrupt 1 = mask interrupt
	8	IM_WSEQ_EINT	1	Write sequencer interrupt mask 0 = do not mask interrupt 1 = mask interrupt
	5	IM_GPIO1_EINT	1	GPIO1 interrupt mask 0 = do not mask interrupt 1 = mask interrupt
	2	IM_FLL_LOCK_EINT	1	FLL Lock interrupt mask 0 = do not mask interrupt 1 = mask interrupt
R129 (81h) Interrupt Polarity	9	GPIO_BCLK_EINT_POL	0	GPIO4 interrupt polarity 0 = active high 1 = active low
	8	WSEQ_EINT_POL	0	Write Sequencer interrupt polarity 0 = active high (interrupt is triggered when WSEQ is busy) 1 = active low (interrupt is triggered when WSEQ is idle)
	5	GPIO1_EINT_POL	0	GPIO1 interrupt polarity 0 = active high 1 = active low
	2	FLL_LOCK_EINT_POL	0	FLL Lock interrupt polarity 0 = active high (interrupt is triggered when FLL Lock is reached) 1 = active low (interrupt is triggered when FLL is not locked)
R130 (82h) Interrupt Debounce	9	GPIO_BCLK_EINT_DB	0	GPIO4 interrupt debounce 0 = disabled 1 = enabled

REGISTER ADDRESS	BIT	LABEL	DEFAULT	DESCRIPTION
	8	WSEQ_EINT_DB	0	Write Sequencer interrupt debounce enable 0 = disabled 1 = enabled
	5	GPIO1_EINT_DB	0	GPIO1 input debounce 0 = disabled 1 = enabled
	2	FLL_LOCK_EINT_D B	0	FLL Lock debounce 0 = disabled 1 = enabled

Table 54 Interrupt Control

CONTROL INTERFACE

The WM8912 is controlled by writing to registers through a 2-wire serial control interface. Readback is available for all registers, including Chip ID, power management status and GPIO status.

Note that, if it cannot be assured that MCLK is present when accessing the register map, then it is required to set CLK_SYS_ENA = 0 to ensure correct operation. See "Clocking and Sample Rates" for details of CLK_SYS_ENA.

The WM8912 is a slave device on the control interface; SCLK is a clock input, while SDA is a bi-directional data pin. To allow arbitration of multiple slaves (and/or multiple masters) on the same interface, the WM8912 transmits logic 1 by tri-stating the SDA pin, rather than pulling it high. An external pull-up resistor is required to pull the SDA line high so that the logic 1 can be recognised by the master.

In order to allow many devices to share a single 2-wire control bus, every device on the bus has a unique 8-bit device ID (this is not the same as the 8-bit address of each register in the WM8912). The WM8912 device ID is 0011 0100 (34h). The LSB of the device ID is the Read/Write bit; this bit is set to logic 1 for "Read" and logic 0 for "Write".

The WM8912 operates as a slave device only. The controller indicates the start of data transfer with a high to low transition on SDA while SCLK remains high. This indicates that a device ID, register address and data will follow. The WM8912 responds to the start condition and shifts in the next eight bits on SDA (8-bit device ID including Read/Write bit, MSB first). If the device ID received matches the device ID of the WM8912, then the WM8912 responds by pulling SDA low on the next clock pulse (ACK). If the device ID is not recognised or the R/W bit is '1' when operating in write only mode, the WM8912 returns to the idle condition and waits for a new start condition and valid address.

If the device ID matches the device ID of the WM8912, the data transfer continues as described below. The controller indicates the end of data transfer with a low to high transition on SDA while SCLK remains high. After receiving a complete address and data sequence the WM8912 returns to the idle state and waits for another start condition. If a start or stop condition is detected out of sequence at any point during data transfer (i.e. SDA changes while SCLK is high), the device returns to the idle condition.

The WM8912 supports the following read and write operations:

- Single write
- Single read
- Multiple write using auto-increment
- Multiple read using auto-increment

The sequence of signals associated with a single register write operation is illustrated in Figure 46.

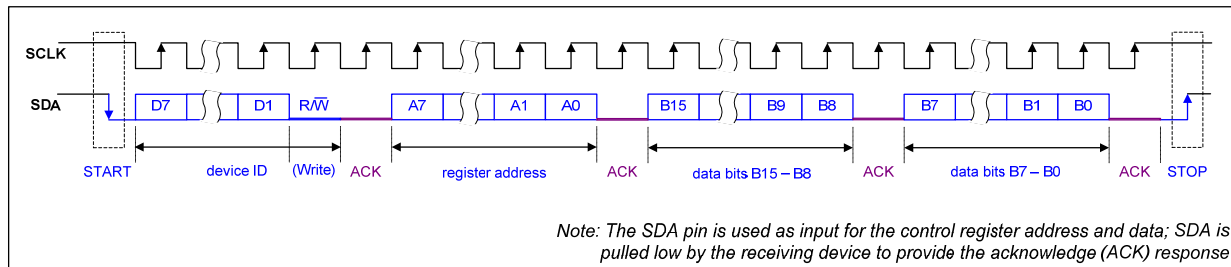

Figure 46 Control Interface Register Write

The sequence of signals associated with a single register read operation is illustrated in Figure 47.

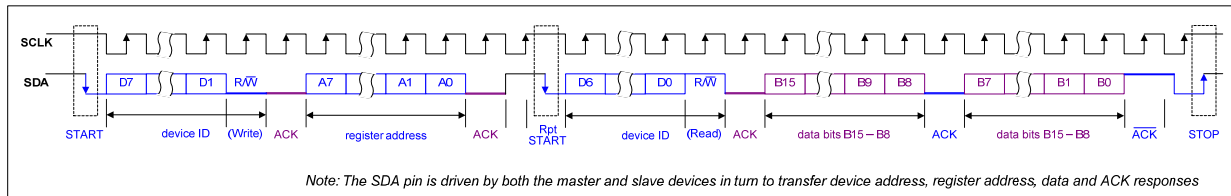

Figure 47 Control Interface Register Read

The Control Interface also supports other register operations, as listed above. The interface protocol for these operations is summarised below. The terminology used in the following figures is detailed in Table 55.

Note that multiple write and multiple read operations are supported using the auto-increment mode. This feature enables the host processor to access sequential blocks of the data in the WM8912 register map faster than is possible with single register operations.

TERMINOLOGY		DESCRIPTION
S		Start Condition
Sr		Repeated start
A		Acknowledge (SDA Low)
\bar{A}		Not Acknowledge (SDA High)
P		Stop Condition
R/ \bar{W}	ReadNotWrite	0 = Write 1 = Read
[White field]		Data flow from bus master to WM8912
[Grey field]		Data flow from WM8912 to bus master

Table 55 Control Interface Terminology

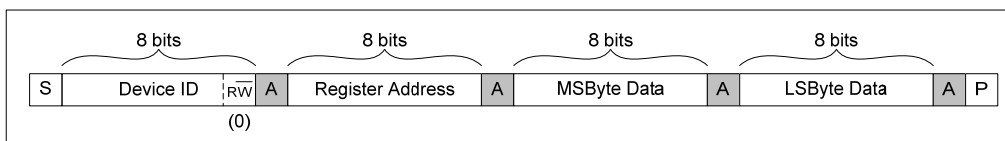

Figure 48 Single Register Write to Specified Address

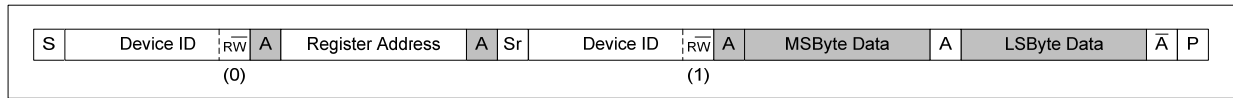

Figure 49 Single Register Read from Specified Address

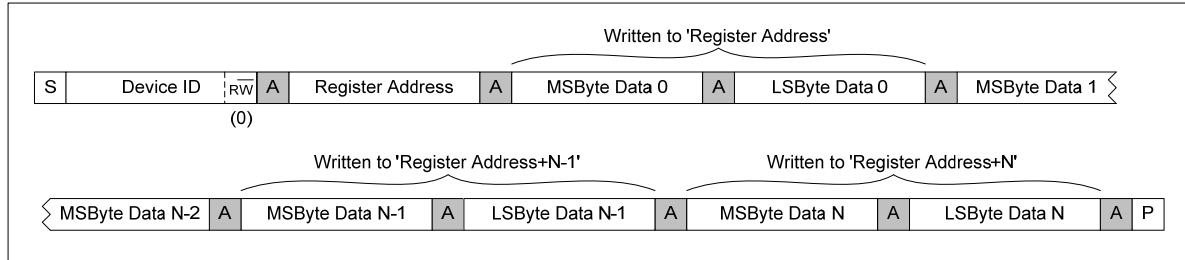

Figure 50 Multiple Register Write to Specified Address using Auto-increment

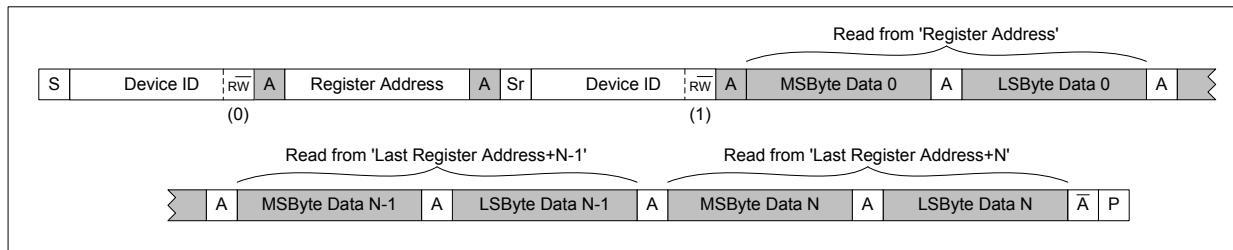

Figure 51 Multiple Register Read from Specified Address using Auto-increment

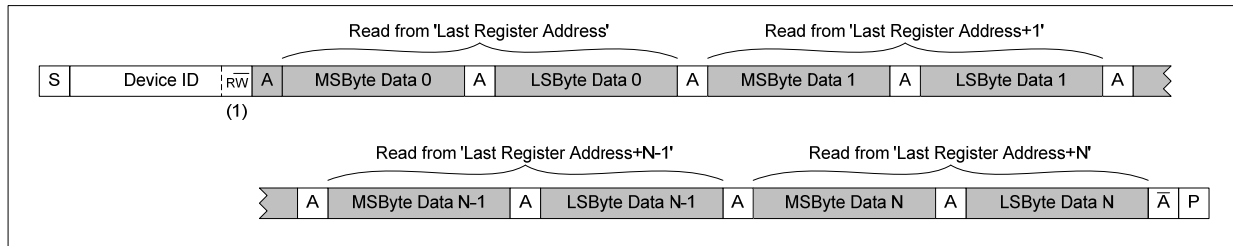

Figure 52 Multiple Register Read from Last Address using Auto-increment

CONTROL WRITE SEQUENCER

The Control Write Sequencer is a programmable unit that forms part of the WM8912 control interface logic. It provides the ability to perform a sequence of register write operations with the minimum of demands on the host processor - the sequence may be initiated by a single operation from the host processor and then left to execute independently.

Default sequences for Start-Up and Shutdown are provided (see "Default Sequences" section). It is recommended that these default sequences are used unless changes become necessary.

When a sequence is initiated, the sequencer performs a series of pre-defined register writes. The host processor informs the sequencer of the start index of the required sequence within the sequencer's memory. At each step of the sequence, the contents of the selected register fields are read from the sequencer's memory and copied into the WM8912 control registers. This continues sequentially through the sequencer's memory until an "End of Sequence" bit is encountered; at this point, the sequencer stops and an Interrupt status flag is asserted. For cases where the timing of the write sequence is important, a programmable delay can be set for specific steps within the sequence.

Note that the Control Write Sequencer's internal clock is derived from the internal clock SYSCLK. An external MCLK signal must be present when using the Control Write Sequencer, and SYSCLK must be enabled by setting CLK_SYS_ENA (see "Clocking and Sample Rates"). The clock division from MCLK is handled transparently by the WM8912 without user intervention, as long as MCLK and sample rates are set correctly.

INITIATING A SEQUENCE

The Register fields associated with running the Control Write Sequencer are described in Table 56.

The Write Sequencer Clock is enabled by setting the WSEQ_ENA bit. Note that the operation of the Control Write Sequencer also requires the internal clock SYSCLK to be enabled via the CLK_SYS_ENA (see "Clocking and Sample Rates").

The start index of the required sequence must be written to the WSEQ_START_INDEX field. Setting the WSEQ_START bit initiates the sequencer at the given start index.

The Write Sequencer can be interrupted by writing a logic 1 to the WSEQ_ABORT bit.

The current status of the Write Sequencer can be read using two further register fields - when the WSEQ_BUSY bit is asserted, this indicates that the Write Sequencer is busy. Note that, whilst the Control Write Sequencer is running a sequence (indicated by the WSEQ_BUSY bit), normal read/write operations to the Control Registers cannot be supported. (The Write Sequencer registers and the Software Reset register can still be accessed when the Sequencer is busy.) The index of the current step in the Write Sequencer can be read from the WSEQ_CURRENT_INDEX field; this is an indicator of the sequencer's progress. On completion of a sequence, this field holds the index of the last step within the last commanded sequence.

When the Write Sequencer reaches the end of a sequence, it asserts the WSEQ_EINT flag in Register R127 (see Table 54 within the "Interrupts" section). This flag can be used to generate an Interrupt Event on completion of the sequence. Note that the WSEQ_EINT flag is asserted to indicate that the Write Sequencer is NOT Busy.

REGISTER ADDRESS	BIT	LABEL	DEFAULT	DESCRIPTION
R108 (6Ch) Write Sequencer 0	8	WSEQ_ENA	0	Write Sequencer Enable. 0 = Disabled 1 = Enabled
R111 (6Fh) Write Sequencer 3	9	WSEQ_ABORT	0	Writing a 1 to this bit aborts the current sequence and returns control of the device back to the serial control interface.

REGISTER ADDRESS	BIT	LABEL	DEFAULT	DESCRIPTION
	8	WSEQ_START	0	Writing a 1 to this bit starts the write sequencer at the memory location indicated by the WSEQ_START_INDEX field. The sequence continues until it reaches an "End of sequence" flag. At the end of the sequence, this bit will be reset by the Write Sequencer.
	5:0	WSEQ_START_INDEX [5:0]	00_0000	Sequence Start Index. This is the memory location of the first command in the selected sequence. 0 to 31 = RAM addresses 32 to 48 = ROM addresses 49 to 63 = Reserved
R112 (70h) Write Sequencer 4	9:4	WSEQ_CURRENT_INDEX [5:0]	00_0000	Sequence Current Index (read only): This is the location of the most recently accessed command in the write sequencer memory.
	0	WSEQ_BUSY	0	Sequencer Busy flag (read only): 0 = Sequencer idle 1 = Sequencer busy Note: it is not possible to write to control registers via the control interface while the Sequencer is Busy.

Table 56 Write Sequencer Control - Initiating a Sequence

PROGRAMMING A SEQUENCE

A sequence consists of write operations to data bits (or groups of bits) within the control registers. The register fields associated with programming the Control Write Sequencer are described in Table 57.

For each step of the sequence being programmed, the Sequencer Index must be written to the WSEQ_WRITE_INDEX field. The values 0 to 31 correspond to all the available RAM addresses within the Write Sequencer memory. (Note that memory addresses 32 to 48 also exist, but these are ROM addresses, which are not programmable.)

Having set the Index as described above, Register R109 must be written to (containing the Control Register Address, the Start Bit Position and the Field Width applicable to this step of the sequence). Also, Register R110 must be written to (containing the Register Data, the End of Sequence flag and the Delay time required after this step is executed). After writing to these two registers, the next step in the sequence may be programmed by updating WSEQ_WRITE_INDEX and repeating the procedure.

WSEQ_ADDR is an 8-bit field containing the Control Register Address in which the data should be written.

WSEQ_DATA_START is a 4-bit field which identifies the LSB position within the selected Control Register to which the data should be written. Setting WSEQ_DATA_START = 0100 will cause 1-bit data to be written to bit 4. With this setting, 4-bit data would be written to bits 7:4 and so on.

WSEQ_DATA_WIDTH is a 3-bit field which identifies the width of the data block to be written. This enables selected portions of a Control Register to be updated without any concern for other bits within the same register, eliminating the need for read-modify-write procedures. Values of 0 to 7 correspond to data widths of 1 to 8 respectively. For example, setting WSEQ_DATA_WIDTH = 010 will cause a 3-bit data block to be written. Note that the maximum value of this field corresponds to an 8-bit data block; writing to register fields greater than 8 bits wide must be performed using two separate operations of the Control Write Sequencer.

WSEQ_DATA is an 8-bit field which contains the data to be written to the selected Control Register. The WSEQ_DATA_WIDTH field determines how many of these bits are written to the selected register; the most significant bits (above the number indicated by WSEQ_DATA_WIDTH) are ignored.

WSEQ_DELAY is a 4-bit field which controls the waiting time between the current step and the next step in the sequence. The total delay time per step (including execution) is given by:

$$T = k \times (2^{WSEQ_DELAY} + 8)$$

where $k = 62.5\mu\text{s}$ (under recommended operating conditions)

This gives a useful range of execution/delay times from $562\mu\text{s}$ up to 2.048s per step.

WSEQ_EOS is a 1-bit field which indicates the End of Sequence. If this bit is set, then the Control Write Sequencer will automatically stop after this step has been executed.

REGISTER ADDRESS	BIT	LABEL	DEFAULT	DESCRIPTION
R108 (6Ch) Write Sequencer 0	4:0	WSEQ_WRITE_INDEX [4:0]	0_0000	Sequence Write Index. This is the memory location to which any updates to R109 and R110 will be copied. 0 to 31 = RAM addresses
R109 (6Dh) Write Sequencer 1	14:12	WSEQ_DATA_WIDTH [2:0]	000	Width of the data block written in this sequence step. 000 = 1 bit 001 = 2 bits 010 = 3 bits 011 = 4 bits 100 = 5 bits 101 = 6 bits 110 = 7 bits 111 = 8 bits
	11:8	WSEQ_DATA_START [3:0]	0000	Bit position of the LSB of the data block written in this sequence step. 0000 = Bit 0 ... 1111 = Bit 15
	7:0	WSEQ_ADDR [7:0]	0000_0000	Control Register Address to be written to in this sequence step.
R110 (6Eh) Write Sequencer 2	14	WSEQ_EOS	0	End of Sequence flag. This bit indicates whether the Control Write Sequencer should stop after executing this step. 0 = Not end of sequence 1 = End of sequence (Stop the sequencer after this step).
	11:8	WSEQ_DELAY [3:0]	0000	Time delay after executing this step. Total delay time per step (including execution)= $62.5\mu\text{s} \times (2^{WSEQ_DELAY} + 8)$
	7:0	WSEQ_DATA [7:0]	0000_0000	Data to be written in this sequence step. When the data width is less than 8 bits, then one or more of the MSBs of WSEQ_DATA are ignored. It is recommended that unused bits be set to 0.

Table 57 Write Sequencer Control - Programming a Sequence

Note that a 'Dummy' write can be inserted into a control sequence by commanding the sequencer to write a value of 0 to bit 0 of Register R255 (FFh). This is effectively a write to a non-existent register

location. This can be used in order to create placeholders ready for easy adaptation of the sequence. For example, a sequence could be defined to power-up a mono signal path from DACL to headphone, with a 'dummy' write included to leave space for easy modification to a stereo signal path configuration. Dummy writes can also be used in order to implement additional time delays between register writes. Dummy writes are included in the default start-up sequence – see Table 59.

In summary, the Control Register to be written is set by the WSEQ_ADDR field. The data bits that are written are determined by a combination of WSEQ_DATA_START, WSEQ_DATA_WIDTH and WSEQ_DATA. This is illustrated below for an example case of writing to the VMID_RES field within Register R5 (05h).

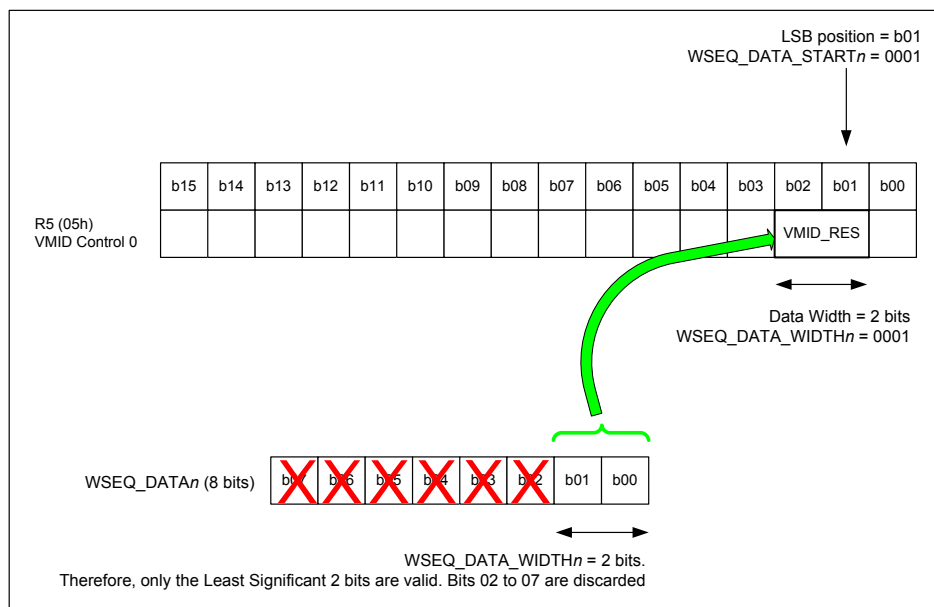

Figure 53 Control Write Sequencer Example

In this example, the Start Position is bit 01 (WSEQ_DATA_START = 0001b) and the Data width is 2 bits (WSEQ_DATA_WIDTH = 0001b). With these settings, the Control Write Sequencer would updated the Control Register R5 [2:1] with the contents of WSEQ_DATA [1:0].

DEFAULT SEQUENCES

When the WM8912 is powered up, two Control Write Sequences are available through default settings in both RAM and ROM memory locations. The purpose of these sequences, and the register write required to initiate them, is summarised in Table 58. A single register write will initiate the sequence in both cases.

WSEQ START INDEX	WSEQ FINISH INDEX	PURPOSE	TO INITIATE
0 (00h)	22 (16h)	Start-Up sequence	Write 0100h to Register R111 (6Fh)
25 (19h)	39 (27h)	Shutdown sequence	Write 0119h to Register R111 (6Fh)

Table 58 Write Sequencer Default Sequences

Note on Shutdown sequence: The instruction at Index Address 25 (19h) shorts the outputs LINEOUTL and LINEOUTR. If the Line outputs are not in use at the time the sequence is run, then the sequence could, instead, be started at Index Address 26.

Index addresses 0 to 24 may be programmed to users' own settings at any time, as described in "Programming a Sequence". Users' own settings remain in memory and are not affected by software resets (i.e. writing to Register R0). However, any non-default sequences are lost when the device is powered down.

START-UP SEQUENCE

The Start-up sequence is initiated by writing 0100h to Register R111 (6Fh). This single operation starts the Control Write Sequencer at Index Address 0 (00h) and executes the sequence defined in Table 59.

For typical clocking configurations with MCLK=12.288MHz, this sequence takes approximately 300ms to run.

Note that, for fast startup, step 18 may be overwritten with dummy data in order to achieve startup within 50ms (see "Quick Start-Up and Shutdown").

WSEQ INDEX	REGISTER ADDRESS	WIDTH	START	DATA	DELAY	EOS	DESCRIPTION
0 (00h)	R4 (04h)	5 bits	Bit 0	1Ah	0h	0b	BIAS_ENA = 0 (delay = 0.5625ms)
1 (01h)	R5 (05h)	8 bits	Bit 0	47h	6h	0b	VMID_RES [1:0] = 11b VMID_ENA = 1 (delay = 4.5ms)
2 (02h)	R5 (05h)	2 bits	Bit 1	01h	0h	0b	VMID_RES [1:0] = 01b (delay = 0.5625ms)
3 (03h)	R4 (04h)	1 bit	Bit 0	01h	0h	0b	BIAS_ENA = 1 (delay = 0.5625ms)
4 (04h)	R14 (0Eh)	2 bits	Bit 0	03h	0h	0b	HPL_PGA_ENA = 1 HPR_PGA_ENA = 1 (delay = 0.5625ms)
5 (05h)	R15 (0Fh)	2 bits	Bit 0	03h	0h	0b	LINEOUTL_PGA_ENA = 1 LINEOUTR_PGA_ENA = 1 (delay = 0.5625ms)
6 (06h)	R22 (16h)	1 bit	Bit 1	01h	0h	0b	CLK_DSP_ENA = 1 (delay = 0.5625ms)
7 (07h)	R18 (12h)	2 bits	Bit 2	03h	5h	0b	DACL_ENA = 1 DACR_ENA = 1 (delay = 2.5ms)
8 (08h)	R255 (FFh)	1 bit	Bit 0	00h	0h	0b	Dummy Write for expansion (delay = 0.5625ms)
9 (09h)	R4 (04h)	1 bit	Bit 4	00h	0h	0b	(delay = 0.5625ms)
10 (0Ah)	R98 (62h)	1 bit	Bit 0	01h	6h	0b	CP_ENA = 1 (delay = 4.5ms)
11 (0Bh)	R255 (FFh)	1 bit	Bit 0	00h	0h	0b	Dummy Write for expansion (delay = 0.5625ms)
12 (0Ch)	R90 (5Ah)	8 bits	Bit 0	11h	0h	0b	HPL_ENA = 1 HPR_ENA = 1 (delay = 0.5625ms)
13 (0Dh)	R94 (5Eh)	8 bits	Bit 0	11h	0h	0b	LINEOUTL_ENA = 1 LINEOUTR_ENA = 1 (delay = 0.5625ms)
14 (0Eh)	R90 (5Ah)	8 bits	Bit 0	33h	0h	0b	HPL_ENA_DLY = 1 HPR_ENA_DLY = 1 (delay = 0.5625ms)
15 (0Fh)	R94 (5Eh)	8 bits	Bit 0	33h	0h	0b	LINEOUTL_ENA_DLY = 1

WSEQ INDEX	REGISTER ADDRESS	WIDTH	START	DATA	DELAY	EOS	DESCRIPTION
							LINEOUTR_ENA_DLY = 1 (delay = 0.5625ms)
16 (10h)	R67 (43h)	4 bits	Bit 0	0Fh	Ch	0b	DCS_ENA_CHAN_0 = 1 DCS_ENA_CHAN_1 = 1 DCS_ENA_CHAN_2 = 1 DCS_ENA_CHAN_3 = 1 (delay = 0.5625ms)
17 (11h)	R68 (44h)	8 bits	Bit 0	F0h	0h	0b	DCS_TRIG_STARTUP_0 = 1 DCS_TRIG_STARTUP_1 = 1 DCS_TRIG_STARTUP_2 = 1 DCS_TRIG_STARTUP_3 = 1 (delay = 256.5ms)
18 (12h)	R255 (FFh)	1 bit	Bit 0	00h	0h	0b	Dummy Write for expansion (delay = 0.5625ms)
19 (13h)	R90 (5Ah)	8 bits	Bit 0	77h	0h	0b	HPL_ENA_OUTP = 1 HPR_ENA_OUTP = 1 (delay = 0.5625ms)
20 (14h)	R94 (5Eh)	8 bits	Bit 0	77h	0h	0b	LINEOUTL_ENA_OUTP = 1 LINEOUTR_ENA_OUTP = 1 (delay = 0.5625ms)
21 (15h)	R90 (5Ah)	8 bits	Bit 0	FFh	0h	0b	HPL_RMV_SHORT = 1 HPR_RMV_SHORT = 1 (delay = 0.5625ms)
22 (16h)	R94 (5Eh)	8 bits	Bit 0	FFh	0h	1b	LINEOUTL_RMV_SHORT = 1 LINEOUTR_RMV_SHORT = 1 End of Sequence
23 (17h)	R255 (FFh)	1 bit	Bit 0	00h	0h	0b	Spare
24 (18h)	R255 (FFh)	1 bit	Bit 0	00h	0h	0b	Spare

Table 59 Start-up Sequence

SHUTDOWN SEQUENCE

The Shutdown sequence is initiated by writing 0119h to Register R111 (6Fh). This single operation starts the Control Write Sequencer at Index Address 25 (19h) and executes the sequence defined in Table 60.

For typical clocking configurations with MCLK=12.288MHz, this sequence takes approximately 350ms to run.

WSEQ INDEX	REGISTER ADDRESS	WIDTH	START	DATA	DELAY	EOS	DESCRIPTION
25 (19h)	R94 (5Eh)	8 bits	Bit 0	77h	0h	0b	LINEOUTL_RMV_SHORT = 0 LINEOUTR_RMV_SHORT = 0 (delay = 0.5625ms)
26 (1Ah)	R90 (5Ah)	8 bits	Bit 0	77h	0h	0b	HPL_RMV_SHORT = 0 HPR_RMV_SHORT = 0 (delay = 0.5625ms)
27 (1Bh)	R90 (5Ah)	8 bits	Bit 0	00h	0h	0b	HPL_ENA_OUTP = 0 HPL_ENA_DLY = 0 HPL_ENA = 0 HPR_ENA_OUTP = 0 HPR_ENA_DLY = 0 HPR_ENA = 0

WSEQ INDEX	REGISTER ADDRESS	WIDTH	START	DATA	DELAY	EOS	DESCRIPTION
							(delay = 0.5625ms)
28 (1Ch)	R94 (5Eh)	8 bits	Bit 0	00h	0h	0b	LINEOUTL_ENA_OUTP = 0 LINEOUTL_ENA_DLY = 0 LINEOUTL_ENA = 0 LINEOUTR_ENA_OUTP = 0 LINEOUTR_ENA_DLY = 0 LINEOUTR_ENA = 0 (delay = 0.5625ms)
29 (1Dh)	R67 (43h)	4 bits	Bit 0	00h	0h	0b	DCS_ENA_CHAN_0 = 0 DCS_ENA_CHAN_1 = 0 DCS_ENA_CHAN_2 = 0 DCS_ENA_CHAN_3 = 0 (delay = 0.5625ms)
30 (1Eh)	R98 (62h)	1 bit	Bit 0	00h	0h	0b	CP_ENA = 0 (delay = 0.5625ms)
31 (1Fh)	R18 (12h)	2 bits	Bit 2	00h	0h	0b	DACL_ENA = 0 DACR_ENA = 0 (delay = 0.5625ms)
32 (20h)	R22 (16h)	1 bit	Bit 1	00h	0h	0b	CLK_DSP_ENA = 0 (delay = 0.5625ms)
33 (21h)	R14 (0Eh)	2 bits	Bit 0	00h	0h	0b	HPL_PGA_ENA = 0 HPR_PGA_ENA = 0 (delay = 0.5625ms)
34 (22h)	R15 (0Fh)	2 bits	Bit 0	00h	0h	0b	LINEOUTL_PGA_ENA = 0 LINEOUTR_PGA_ENA = 0 (delay = 0.5625ms)
35 (23h)	R4 (04h)	1 bit	Bit 0	00h	0h	0b	BIAS_ENA = 0 (delay = 0.5625ms)
36 (24h)	R5 (05h)	1 bit	Bit 0	00h	Ch	0b	VMID_ENA = 0 (delay = 256.5ms)
37 (25h)	R5 (05h)	1 bit	Bit 0	00h	9h	0b	VMID_ENA = 0 (delay = 32.5ms)
38 (26h)	R5 (05h)	8 bits	Bit 0	00h	0h	0b	VMID_RES [1:0] = 00 VMID_ENA = 0 (delay = 0.5625ms)
39 (27h)	R4 (04h)	2 bits	Bit 0	00h	0h	1b	BIAS_ENA = 0 End of Sequence

Table 60 Shutdown Sequence

POWER-ON RESET

The WM8912 includes an internal Power-On-Reset (POR) circuit, which is used to reset the digital logic into a default state after power up. The POR circuit is powered from AVDD and monitors DCVDD. The internal $\overline{\text{POR}}$ signal is asserted low when AVDD and DCVDD are below minimum thresholds.

The specific behaviour of the circuit will vary, depending on the relative timing of the supply voltages. Typical scenarios are illustrated in Figure 54 and Figure 55.

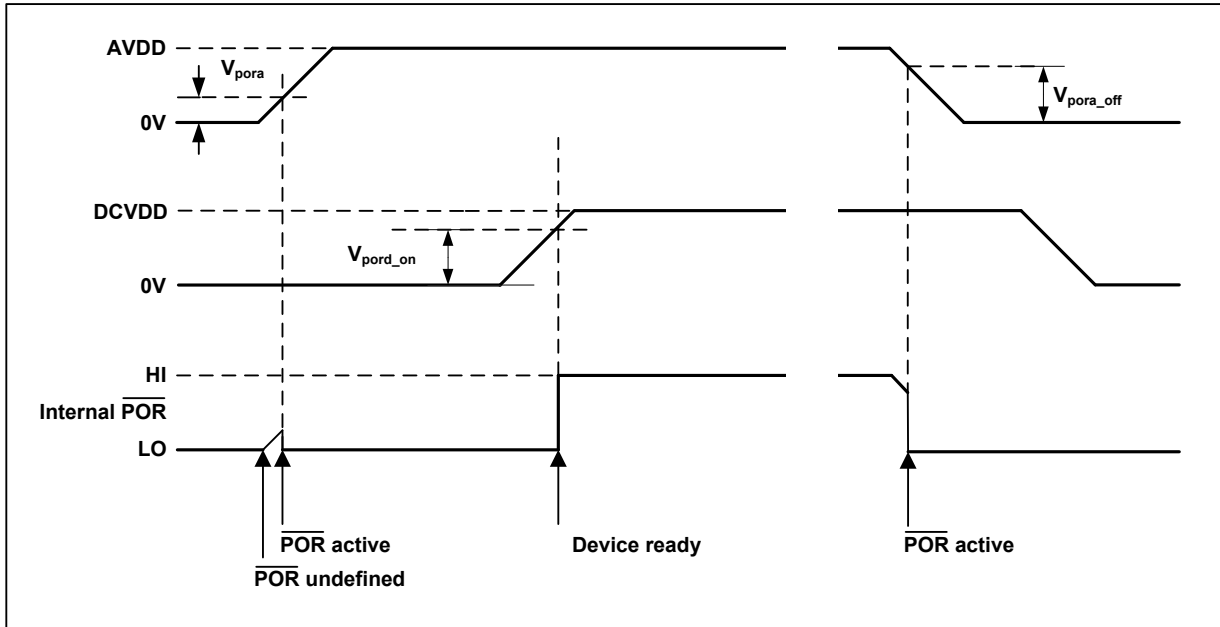

Figure 54 Power On Reset Timing - AVDD Enabled First

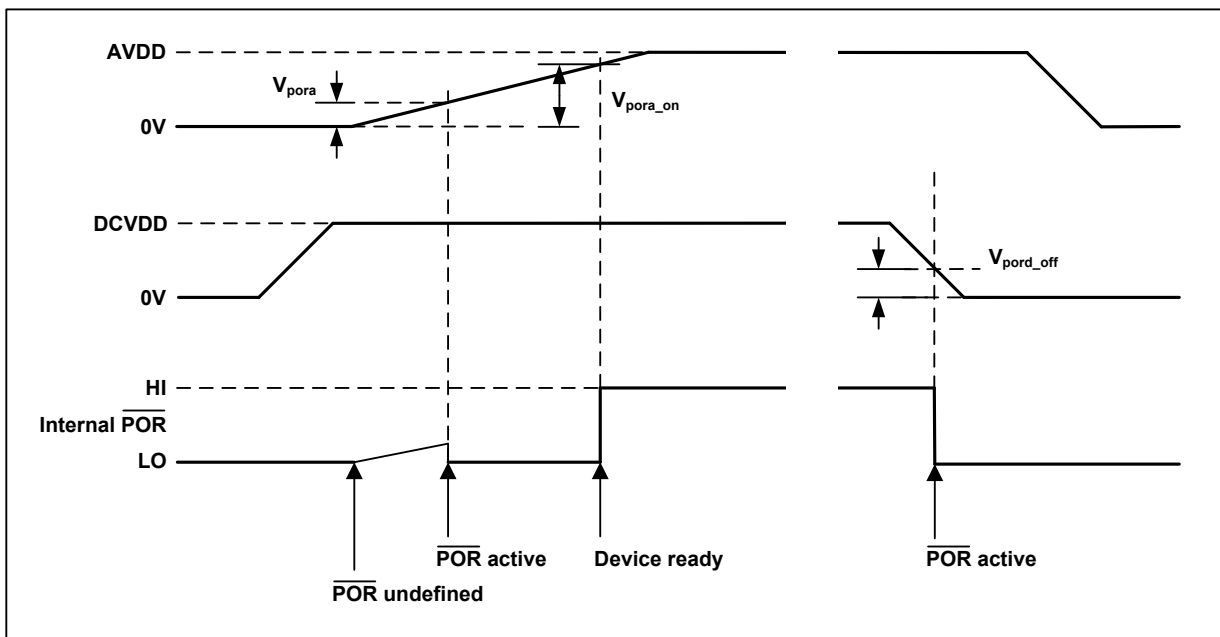

Figure 55 Power On Reset Timing - DCVDD Enabled First

The $\overline{\text{POR}}$ signal is undefined until AVDD has exceeded the minimum threshold, V_{pora} . Once this threshold has been exceeded, $\overline{\text{POR}}$ is asserted low and the chip is held in reset. In this condition, all writes to the control interface are ignored. Once AVDD and DCVDD have reached their respective power on thresholds, $\overline{\text{POR}}$ is released high, all registers are in their default state, and writes to the control interface may take place.

Note that a minimum power-on reset period, T_{POR} , applies even if AVDD and DCVDD have zero rise time. (This specification is guaranteed by design rather than test.)

On power down, $\overline{\text{POR}}$ is asserted low when any of AVDD or DCVDD falls below their respective power-down thresholds.

Typical Power-On Reset parameters for the WM8912 are defined in Table 61.

SYMBOL	DESCRIPTION	TYP	UNIT
V_{pora}	AVDD threshold below which POR is undefined	0.25	V
$V_{\text{pora_on}}$	Power-On threshold (AVDD)	1.15	V
$V_{\text{pora_off}}$	Power-Off threshold (AVDD)	1.12	V
$V_{\text{pord_on}}$	Power-On threshold (DCVDD)	0.57	V
$V_{\text{pord_off}}$	Power-Off threshold (DCVDD)	0.55	V
T_{POR}	Minimum Power-On Reset period	9.5	μs

Table 61 Typical Power-On Reset Parameters

Notes:

1. If AVDD and DCVDD suffer a brown-out (i.e. drop below the minimum recommended operating level but do not go below $V_{\text{pora_off}}$ or $V_{\text{pord_off}}$) then the chip does not reset and resumes normal operation when the voltage is back to the recommended level again.
2. The chip enters reset at power down when AVDD or DCVDD falls below $V_{\text{pora_off}}$ or $V_{\text{pord_off}}$. This may be important if the supply is turned on and off frequently by a power management system.
3. The minimum T_{por} period is maintained even if DCVDD and AVDD have zero rise time. This specification is guaranteed by design rather than test.

QUICK START-UP AND SHUTDOWN

The WM8912 has the capability to perform a quick start-up and shutdown with a minimum number of register operations. This is achieved using the Control Write Sequencer, which is configured with default start-up settings that set up the device for DAC playback via Headphone and Line output. Assuming a 12.288MHz external clock, the start-up sequence configures the device for 48kHz playback mode.

The default start-up sequence requires three register write operations. The default shutdown sequence requires just a single register write. The minimum procedure for executing the quick start-up and shutdown sequences is described below. See “Control Write Sequencer” for more details.

After the default start-up sequence has been performed, the DC offset correction values will be held in memory, provided that power is maintained and a software reset is not performed. Fast start-up using the stored values of DC offset correction is also possible, as described below.

QUICK START-UP (DEFAULT SEQUENCE)

An external clock must be applied to MCLK. Assuming 12.288MHz input clock, the start-up sequence will take approximately 300ms to complete.

The following register operations will initiate the quick start-up sequence.

REGISTER ADDRESS	VALUE	DESCRIPTION
R108 (6Ch) Write Sequencer 0	0100h	WSEQ_ENA = 1 WSEQ_WRITE_INDEX = 0_0000
R111 (6Fh) Write Sequencer 3	0100h	WSEQ_ABORT = 0 WSEQ_START = 1 WSEQ_START_INDEX = 0_0000
R33 (21h) DAC Digital 1	0000h	DAC_MONO = 0 DAC_SB_FILT = 0 DAC_MUTERATE = 0 DAC_UNMUTE_RAMP = 0 DAC_OSR128 = 0 DAC_MUTE = 0 DEEMPH = 00

Table 62 Quick Start-up Control

The WSEQ_BUSY bit (in Register R112, see Table 56) will be set to 1 while the sequence runs. When this bit returns to 0, the device has been set up and is ready for DAC playback operation.

FAST START-UP FROM STANDBY

The default start-up sequence runs the DC Servo to remove DC offsets from the outputs. The offset for this path selection is then stored in memory. Provided that power is maintained to the chip, and a software reset is not performed, then the DC offset correction will be held in memory on the WM8912. This allows the DC Servo calibrations to be omitted from the start-up sequence if the offset correction has already been performed. By omitting this part of the start-up sequence, a fast start-up time of less than 50ms can be achieved.

The register write sequence described in Table 63 replaces the default DC Servo operation with dummy operations, allowing a fast start-up to be achieved, assuming the device is initially in a standby condition with DC offset correction previously performed.

Note that, if power is removed from the WM8912 or if a software reset is performed, then the default sequence will be restored, and the DC offset correction will be necessary on the output paths once more.

REGISTER ADDRESS	VALUE	DESCRIPTION
R108 (6Ch) Write Sequencer 0	0111h	WSEQ_ENA = 1 WSEQ_WRITE_INDEX = 1_0001
R109 (6Dh) Write Sequencer 1	00FFh	WSEQ_DATA_WIDTH = 000 WSEQ_DATA_START = 0000 WSEQ_ADDR = 1111_1111
R110 (6Eh) Write Sequencer 2	0000h	WSEQ_EOS = 0 WSEQ_DELAY = 0000 WSEQ_DATA = 0000_0000
R111 (6Fh) Write Sequencer 3	0100h	WSEQ_ABORT = 0 WSEQ_START = 1 WSEQ_START_INDEX = 00_0000
R33 (21h) DAC Digital 1	0000h	DAC_MONO = 0 DAC_SB_FILT = 0 DAC_MUTERATE = 0 DAC_UNMUTE_RAMP = 0 DAC_OSR128 = 0 DAC_MUTE = 0 DEEMPH = 00

Table 63 Fast Start-up from Standby Control

The WSEQ_BUSY bit (in Register R112, see Table 56) will be set to 1 while the sequence runs. When this bit returns to 0, the device has been set up and is ready for DAC playback operation.

QUICK SHUTDOWN (DEFAULT SEQUENCE)

The default shutdown sequences assumes the initial device conditions are as configured by the default start-up sequence. Assuming 12.288MHz input clock, the shutdown sequence will take approximately 350ms to complete.

The following register operation will initiate the default shutdown sequence.

REGISTER ADDRESS	VALUE	DESCRIPTION
R111 (6Fh) Write Sequencer 3	0119h	WSEQ_ABORT = 0 WSEQ_START = 1 WSEQ_START_INDEX = 19h

Table 64 Quick Shutdown Control

The WSEQ_BUSY bit (in Register R112, see Table 56) will be set to 1 while the sequence runs. When this bit returns to 0, the system clock can be disabled (CLK_SYS_ENA=0) and MCLK can be stopped.

SOFTWARE RESET AND CHIP ID

A Software Reset can be commanded by writing to Register R0. This is a read-only register field and the contents will not be affected by writing to this Register.

The Chip ID can be read back from Register R0.

REGISTER ADDRESS	BIT	LABEL	DEFAULT	DESCRIPTION
R0 (00h) SW Reset and ID	15:0	SW_RST_DE V_ID1 [15:0]	8904h	Writing to this register resets all registers to their default state. Reading from this register will indicate Device ID 8904h.

Table 65 Software Reset and Chip ID

REGISTER MAP

Dec Addr	Hex Addr	Name	15	14	13	12	11	10	9	8	7	6	5	4	3	2	1	0	Bin Default	
0	00	SW Reset and ID	SW_RST_DEV_ID[15:0]																1000_1001_0000_0100	
4	04	Bias Control 0	0	0	0	0	0	0	0	0	0	0	0	0	1	1	0	0	BIAS_ENA	0000_0000_0001_1000
5	05	VMD Control 0	0	0	0	0	0	0	0	0	0	0	0	0	0	0	0	0	VMD_ENA	0000_0000_0000_0000
14	0E	Power Management 2	0	0	0	0	0	0	0	0	0	0	0	0	0	0	0	0	HPL_PGA_ENA	0000_0000_0000_0000
15	0F	Power Management 3	0	0	0	0	0	0	0	0	0	0	0	0	0	0	0	0	LINEOUT_PGA_ENA	0000_0000_0000_0000
16	12	Power Management 6	0	0	0	0	0	0	0	0	0	0	0	0	0	0	0	0	LINEOUT_PGA_ENA	0000_0000_0000_0000
20	14	Clock Rates 0	1	TOCLK_RATE_V16	0	0	0	0	0	0	0	0	0	0	1	1	1	1	MCLK_DIV	1000_1100_0100_1110
21	15	Clock Rates 1	0	0	0	0	0	0	0	0	0	0	0	0	0	0	0	0	SAMPLE_RATE[2:0]	0000_1100_0000_0101
22	16	Clock Rates 2	0	0	0	0	0	0	0	0	0	0	0	0	0	0	0	0	TOCLK_ENA	0000_0000_0000_0000
24	18	Audio Interface 0	0	0	0	0	0	0	0	0	0	0	0	0	0	0	0	0	OPCLK_ENA	0000_0000_0100_0000
25	19	Audio Interface 1	0	0	0	0	0	0	0	0	0	0	0	0	0	0	0	0	OPCLK_COMP	0000_0000_0100_0000
26	1A	Audio Interface 2	0	0	0	0	0	0	0	0	0	0	0	0	0	0	0	0	AF_FMT[10]	0000_0000_0000_1010
27	1B	Audio Interface 3	0	0	0	0	0	0	0	0	0	0	0	0	0	0	0	0	BCLK_DIV[4:0]	0000_0000_1110_0100
30	1E	DAC Digital Volume Left	0	0	0	0	0	0	0	0	0	0	0	0	0	0	0	0	OPCLK_RATE[10:0]	0000_0000_0100_0000
31	1F	DAC Digital Volume Right	0	0	0	0	0	0	0	0	0	0	0	0	0	0	0	0	OPCLK_RATE[10:0]	0000_0000_0100_0000
33	21	DAC Digital 1	0	0	0	0	0	0	0	0	0	0	0	0	0	0	0	0	OPCLK_RATE[10:0]	0000_0000_0100_0000
40	28	DRC 0	0	0	0	0	0	0	0	0	0	0	0	0	0	0	0	0	OPCLK_RATE[10:0]	0000_0000_0100_0000
41	29	DRC 1	0	0	0	0	0	0	0	0	0	0	0	0	0	0	0	0	OPCLK_RATE[10:0]	0000_0000_0100_0000
42	2A	DRC 2	0	0	0	0	0	0	0	0	0	0	0	0	0	0	0	0	OPCLK_RATE[10:0]	0000_0000_0100_0000
43	2B	DRC 3	0	0	0	0	0	0	0	0	0	0	0	0	0	0	0	0	OPCLK_RATE[10:0]	0000_0000_0100_0000
57	39	Analogue OUT1 Left	0	0	0	0	0	0	0	0	0	0	0	0	0	0	0	0	OPCLK_RATE[10:0]	0000_0000_0100_0000
58	3A	Analogue OUT1 Right	0	0	0	0	0	0	0	0	0	0	0	0	0	0	0	0	OPCLK_RATE[10:0]	0000_0000_0100_0000
59	3B	Analogue OUT2 Left	0	0	0	0	0	0	0	0	0	0	0	0	0	0	0	0	OPCLK_RATE[10:0]	0000_0000_0100_0000
60	3C	Analogue OUT2 Right	0	0	0	0	0	0	0	0	0	0	0	0	0	0	0	0	OPCLK_RATE[10:0]	0000_0000_0100_0000
67	43	DC Servo 0	0	0	0	0	0	0	0	0	0	0	0	0	0	0	0	0	OPCLK_RATE[10:0]	0000_0000_0100_0000
68	44	DC Servo 1	0	0	0	0	0	0	0	0	0	0	0	0	0	0	0	0	OPCLK_RATE[10:0]	0000_0000_0100_0000
69	45	DC Servo 2	0	0	0	0	0	0	0	0	0	0	0	0	0	0	0	0	OPCLK_RATE[10:0]	0000_0000_0100_0000
71	47	DC Servo 4	0	0	0	0	0	0	0	0	0	0	0	0	0	0	0	0	OPCLK_RATE[10:0]	0000_0000_0100_0000
72	48	DC Servo 5	0	0	0	0	0	0	0	0	0	0	0	0	0	0	0	0	OPCLK_RATE[10:0]	0000_0000_0100_0000

Dec Addr	Hex Addr	Name	15	14	13	12	11	10	9	8	7	6	5	4	3	2	1	0	Bin Default
73		DC Servo 6	0	0	0	0	0	0	0	0		DCS_DAC_WRC_VAL_3[7:0]							0000_0000_0000_0000
74	4A	DC Servo 7	0	0	0	0	0	0	0	0		DCS_DAC_WRC_VAL_2[7:0]							0000_0000_0000_0000
75	4B	DC Servo 8	0	0	0	0	0	0	0	0		DCS_DAC_WRC_VAL_1[7:0]							0000_0000_0000_0000
76	4C	DC Servo 9	0	0	0	0	0	0	0	0		DCS_DAC_WRC_VAL_0[7:0]							0000_0000_0000_0000
77	4D	DC Servo Feedback 0	0	0	0	0	0	DCS_CAL_COMPLETE[3:0]				DCS_CAL_COMPLETE[3:0]			DCS_STARTUP_COMPLETE[3:0]				0000_0000_0000_0000
90	5A	Analogue HP 0	0	0	0	0	0	0	0	0	HPL_RMV_SHO_RT	HPL_EVA_OUTP	HPL_EVA_DLY	HPL_EVA	HPL_EVA_OUTP	HPL_EVA_DLY	HPL_EVA	HPL_EVA	0000_0000_0000_0000
94	5E	Analogue Lineout 0	0	0	0	0	0	0	0	0	LINEOUTL_RMV_SHORT	LINEOUTL_EVA_OUTP	LINEOUTL_EVA_DLY	LINEOUTL_EVA	LINEOUTR_EVA_OUTP	LINEOUTR_EVA_DLY	LINEOUTR_EVA	LINEOUTR_EVA	0000_0000_0000_0000
98	62	Charge Pump 0	0	0	0	0	0	0	0	0	0	0	0	0	0	0	0	0	0000_0000_0000_0000
104	68	Class W0	0	0	0	0	0	0	0	0	0	0	0	0	0	1	0	0	000_0000_0000_0100
108	6C	Write Sequencer 0	0	0	0	0	0	0	0	WSEQ_ENA									0000_0000_0000_0000
109	6D	Write Sequencer 1	0	WSEQ_DATA_START[3:0]										WSEQ_ADDR[7:0]					0000_0000_0000_0000
110	6E	Write Sequencer 2	0	WSEQ_EDOS	0	0	0	WSEQ_DELAY[3:0]						WSEQ_DATA[7:0]					0000_0000_0000_0000
111	6F	Write Sequencer 3	0	0	0	0	0	0	WSEQ_ABORT	WSEQ_START				WSEQ_START_INDEX[5:0]					0000_0000_0000_0000
112	70	Write Sequencer 4	0	0	0	0	0	0		WSEQ_CURRENT_INDEX[5:0]					0	0	0	0	0000_0000_0000_0000
116	74	FLL Control 1	0	0	0	0	0	0	0	0	0	0	0	0	0	0	0	0	0000_0000_0000_0000
117	75	FLL Control 2	0	0	0	0	0	0	0	0	0	0	0	0	0	0	0	0	0000_0000_0000_0111
118	76	FLL Control 3																	0000_0000_0000_0000
119	77	FLL Control 4																	0010_1110_1110_0000
120	78	FLL Control 5	0	0	0	0	0	0	0	0	0	0	0	0	0	1	0	0	0000_0000_0000_0100
121	79	GPIO Control 1	0	0	0	0	0	0	0	0	0	0	0	GPIO_PD					0000_0000_0001_0100
124	7C	GPIO Control 4	0	0	0	0	0	0	0	0	0	0	0	0	0				0000_0000_0000_0000
126	7E	Digital Pulls	0	0	0	0	0	0	0	0	0	0	0	0	0	0	0	0	0000_0000_0000_0000
127	7F	Interrupt Status	0	0	0	0	0	0	0	0	0	0	0	0	0	0	0	0	XXXX_XPPP_PPPP_PPPP
128	80	Interrupt Status Mask	0	0	0	0	0	0	0	0	0	0	0	0	0	0	0	0	1111_1111_1111_1111
129	81	Interrupt Polarity	0	0	0	0	0	0	0	0	0	0	0	0	0	0	0	0	0000_0000_0000_0000
130	82	Interrupt Debounce	0	0	0	0	0	0	0	0	0	0	0	0	0	0	0	0	0000_0000_0000_0000
134		EQ1	0	0	0	0	0	0	0	0	0	0	0	0	0	0	0	0	0000_0000_0000_0000

Dec Addr	Hex Addr	Name	15	14	13	12	11	10	9	8	7	6	5	4	3	2	1	0	Bin Default
135	87	E02	0	0	0	0	0	0	0	0	0	0	0		EQ_B1_GAIN[5:0]				0000_0000_0000_1100
136	88	E03	0	0	0	0	0	0	0	0	0	0	0		EQ_B2_GAIN[5:0]				0000_0000_0000_1100
137	89	E04	0	0	0	0	0	0	0	0	0	0	0		EQ_B3_GAIN[5:0]				0000_0000_0000_1100
138	8A	E05	0	0	0	0	0	0	0	0	0	0	0		EQ_B4_GAIN[5:0]				0000_0000_0000_1100
139	8B	E06	0	0	0	0	0	0	0	0	0	0	0		EQ_B5_GAIN[5:0]				0000_0000_0000_1100
140	8C	E07								EQ_B1_A[15:0]									0000_1111_1100_1010
141	8D	E08								EQ_B1_B[15:0]									0000_0100_0000_0000
142	8E	E09								EQ_B1_P[5:0]									0000_0000_1100_1000
143	8F	EQ10								EQ_B2_A[15:0]									0000_1110_1011_0101
144	90	EQ11								EQ_B2_B[15:0]									1111_0001_0100_0101
145	91	EQ12								EQ_B2_C[15:0]									0000_1011_0111_0101
146	92	EQ13								EQ_B2_P[5:0]									0000_0001_1100_0101
147	93	EQ14								EQ_B3_A[15:0]									0000_1100_0100_1000
148	94	EQ15								EQ_B3_B[15:0]									1111_0011_0111_0011
149	95	EQ16								EQ_B3_C[15:0]									0000_0100_0100_0100
150	96	EQ17								EQ_B3_P[5:0]									0000_0100_0100_1000
151	97	EQ18								EQ_B4_A[15:0]									0000_0100_1000_1110
152	98	EQ19								EQ_B4_B[15:0]									1111_1000_0010_1001
153	99	EQ20								EQ_B4_C[15:0]									0000_0111_1010_1101
154	9A	EQ21								EQ_B4_P[5:0]									0000_0001_0000_0011
155	9B	EQ22								EQ_B5_A[15:0]									0000_0100_0100_0100
156	9C	EQ23								EQ_B5_B[15:0]									0000_0100_0100_1001
157	9D	EQ24								EQ_B5_P[5:0]									0100_0000_0000_0000
247	F7	FL_NCO_Tst0	0	0	0	0	0	0	0	0	0	0	0	0	0	0	0	0	FL_NCO
248	F8	FL_NCO_Tst1	0	0	0	0	0	0	0	0	0	0	0	0	0	0	0	0	FL_NCO_VAL[5:0]

REGISTER BITS BY ADDRESS

REGISTER ADDRESS	BIT	LABEL	DEFAULT	DESCRIPTION	REFER TO
R0 (00h) SW Reset and ID	15:0	SW_RST_DEV_ID1 [15:0]	1000_1001_0000_0100	Writing to this register resets all registers to their default state. Reading from this register will indicate Device ID 8904h.	

Register 00h SW Reset and ID

REGISTER ADDRESS	BIT	LABEL	DEFAULT	DESCRIPTION	REFER TO
R4 (04h) Bias Control 0	0	BIAS_ENA	0	Enables the Normal bias current generator (for all analogue functions) 0 = Disabled 1 = Enabled	

Register 04h Bias Control 0

REGISTER ADDRESS	BIT	LABEL	DEFAULT	DESCRIPTION	REFER TO
R5 (05h) VMID Control 0	2:1	VMID_RES [1:0]	00	VMID Divider Enable and Select 00 = VMID disabled (for OFF mode) 01 = 2 x 50k divider (for normal operation) 10 = 2 x 250k divider (for low power standby) 11 = 2 x 5k divider (for fast start-up)	
	0	VMID_ENA	0	Enable VMID master bias current source 0 = Disabled 1 = Enabled	

Register 05h VMID Control 0

REGISTER ADDRESS	BIT	LABEL	DEFAULT	DESCRIPTION	REFER TO
R14 (0Eh) Power Management 2	1	HPL_PGA_ENA	0	Left Headphone Output Enable 0 = disabled 1 = enabled	
	0	HPR_PGA_ENA	0	Right Headphone Output Enable 0 = disabled 1 = enabled	

Register 0Eh Power Management 2

REGISTER ADDRESS	BIT	LABEL	DEFAULT	DESCRIPTION	REFER TO
R15 (0Fh) Power Management 3	1	LINEOUTL_PG A_ENA	0	Left Line Output Enable 0 = disabled 1 = enabled	
	0	LINEOUTR_PG A_ENA	0	Right Line Output Enable 0 = disabled 1 = enabled	

Register 0Fh Power Management 3

REGISTER ADDRESS	BIT	LABEL	DEFAULT	DESCRIPTION	REFER TO
R18 (12h) Power Management t6	3	DACL_ENA	0	Left DAC Enable 0 = DAC disabled 1 = DAC enabled	
	2	DACR_ENA	0	Right DAC Enable 0 = DAC disabled 1 = DAC enabled	

Register 12h Power Management 6

REGISTER ADDRESS	BIT	LABEL	DEFAULT	DESCRIPTION	REFER TO
R20 (14h) Clock Rates 0	14	TOCLK_RATE_DIV16	0	TOCLK Rate Divider (/16) 0 = f / 1 1 = f / 16	
	13	TOCLK_RATE_X4	0	TOCLK Rate Multiplier 0 = f x 1 1 = f x 4	
	0	MCLK_DIV	0	Enables divide by 2 on MCLK 0 = SYSCLK = MCLK 1 = SYSCLK = MCLK / 2	

Register 14h Clock Rates 0

REGISTER ADDRESS	BIT	LABEL	DEFAULT	DESCRIPTION	REFER TO
R21 (15h) Clock Rates 1	13:10	CLK_SYS_RATE [3:0]	0011	Selects the SYSCLK / fs ratio 0000 = 64 0001 = 128 0010 = 192 0011 = 256 0100 = 384 0101 = 512 0110 = 768 0111 = 1024 1000 = 1408 1001 = 1536	
	2:0	SAMPLE_RATE [2:0]	101	Selects the Sample Rate (fs) 000 = 8kHz 001 = 11.025kHz, 12kHz 010 = 16kHz 011 = 22.05kHz, 24kHz 100 = 32kHz 101 = 44.1kHz, 48kHz 110 to 111 = Reserved	

Register 15h Clock Rates 1

REGISTER ADDRESS	BIT	LABEL	DEFAULT	DESCRIPTION	REFER TO
R22 (16h) Clock Rates 2	15	MCLK_INV	0	MCLK Invert 0 = MCLK not inverted 1 = MCLK inverted	
	14	SYSCLK_SRC	0	SYSCLK Source Select 0 = MCLK 1 = FLL output	
	12	TOCLK_RATE	0	TOCLK Rate Divider (/2) 0 = f / 2 1 = f / 1	
	3	OPCLK_ENA	0	GPIO Clock Output Enable 0 = disabled 1 = enabled	
	2	CLK_SYS_ENA	0	System Clock enable 0 = Disabled 1 = Enabled	
	1	CLK_DSP_ENA	0	DSP Clock enable 0 = Disabled 1 = Enabled	
	0	TOCLK_ENA	0	Zero Cross timeout enable 0 = Disabled 1 = Enabled	

Register 16h Clock Rates 2

REGISTER ADDRESS	BIT	LABEL	DEFAULT	DESCRIPTION	REFER TO
R24 (18h) Audio Interface 0	12	DACL_DATINV	0	Left DAC Invert 0 = Left DAC output not inverted 1 = Left DAC output inverted	
	11	DACR_DATINV	0	Right DAC Invert 0 = Right DAC output not inverted 1 = Right DAC output inverted	
	10:9	DAC_BOOST [1:0]	00	DAC Digital Input Volume Boost 00 = 0dB 01 = +6dB (Input data must not exceed -6dBFS) 10 = +12dB (Input data must not exceed -12dBFS) 11 = +18dB (Input data must not exceed -18dBFS)	
	5	AIFDACL_SRC	0	Left DAC Data Source Select 0 = Left DAC outputs left channel data 1 = Left DAC outputs right channel data	
	4	AIFDACR_SRC	1	Right DAC Data Source Select 0 = Right DAC outputs left channel data 1 = Right DAC outputs right channel data	
	1	DAC_COMP	0	DAC Companding Enable 0 = disabled 1 = enabled	
	0	DAC_COMPMODE	0	DAC Companding Type 0 = μ -law 1 = A-law	

Register 18h Audio Interface 0

REGISTER ADDRESS	BIT	LABEL	DEFAULT	DESCRIPTION	REFER TO
R25 (19h) Audio Interface 1	13	AIFDAC_TDM	0	DAC TDM Enable 0 = Normal DACDAT operation 1 = TDM enabled on DACDAT	
	12	AIFDAC_TDM_CHAN	0	DACDAT TDM Channel Select 0 = DACDAT data input on slot 0 1 = DACDAT data input on slot 1	
	8	AIF_TRIS	0	Audio Interface Tristate 0 = Audio interface pins operate normally 1 = Tristate all audio interface pins	
	7	AIF_BCLK_INV	0	BCLK Invert 0 = BCLK not inverted 1 = BCLK inverted	
	6	BCLK_DIR	0	Audio Interface BCLK Direction 0 = BCLK is input 1 = BCLK is output	
	4	AIF_LRCLK_INV	0	LRC Polarity / DSP Mode A-B select. Right, left and I2S modes – LRC polarity 0 = Not Inverted 1 = Inverted DSP Mode – Mode A-B select 0 = MSB is available on 2nd BCLK rising edge after LRC rising edge (mode A) 1 = MSB is available on 1st BCLK rising edge after LRC rising edge (mode B)	
	3:2	AIF_WL [1:0]	10	Digital Audio Interface Word Length 00 = 16 bits 01 = 20 bits 10 = 24 bits 11 = 32 bits	
	1:0	AIF_FMT [1:0]	10	Digital Audio Interface Format 00 = Right Justified 01 = Left Justified 10 = I2S 11 = DSP	

Register 19h Audio Interface 1

REGISTER ADDRESS	BIT	LABEL	DEFAULT	DESCRIPTION	REFER TO
R26 (1Ah) Audio Interface 2	11:8	OPCLK_DIV [3:0]	0000	GPIO Output Clock Divider 0000 = SYSCLK 0001 = SYSCLK / 2 0010 = SYSCLK / 3 0011 = SYSCLK / 4 0100 = SYSCLK / 5.5 0101 = SYSCLK / 6 0110 = SYSCLK / 8 0111 = SYSCLK / 12 1000 = SYSCLK / 16	

REGISTER ADDRESS	BIT	LABEL	DEFAULT	DESCRIPTION	REFER TO
				1001 to 1111 = Reserved	
	4:0	BCLK_DIV [4:0]	0_0100	BCLK Frequency (Master Mode) 00000 = SYSCLK 00001 = SYSCLK / 1.5 00010 = SYSCLK / 2 00011 = SYSCLK / 3 00100 = SYSCLK / 4 00101 = SYSCLK / 5 00110 = SYSCLK / 5.5 00111 = SYSCLK / 6 01000 = SYSCLK / 8 (default) 01001 = SYSCLK / 10 01010 = SYSCLK / 11 01011 = SYSCLK / 12 01100 = SYSCLK / 16 01101 = SYSCLK / 20 01110 = SYSCLK / 22 01111 = SYSCLK / 24 10000 = SYSCLK / 25 10001 = SYSCLK / 30 10010 = SYSCLK / 32 10011 = SYSCLK / 44 10100 = SYSCLK / 48	

Register 1Ah Audio Interface 2

REGISTER ADDRESS	BIT	LABEL	DEFAULT	DESCRIPTION	REFER TO
R27 (1Bh) Audio Interface 3	11	LRCLK_DIR	0	Audio Interface LRC Direction 0 = LRC is input 1 = LRC is output	
	10:0	LRCLK_RATE [10:0]	000_0100_0000	LRC Rate (Master Mode) LRC clock output = BCLK / LRCLK_RATE Integer (LSB = 1) Valid range: 8 to 2047	

Register 1Bh Audio Interface 3

REGISTER ADDRESS	BIT	LABEL	DEFAULT	DESCRIPTION	REFER TO
R30 (1Eh) DAC Digital Volume Left	8	DAC_VU	0	DAC Volume Update Writing a 1 to this bit causes left and right DAC volume to be updated simultaneously	
	7:0	DACL_VOL [7:0]	1100_0000	Left DAC Digital Volume 00h = Mute 01h = -71.625dB 02h = -71.250dB ... (0.375dB steps) C0h to FFh = 0dB	

Register 1Eh DAC Digital Volume Left

REGISTER ADDRESS	BIT	LABEL	DEFAULT	DESCRIPTION	REFER TO
R31 (1Fh) DAC Digital Volume Right	8	DAC_VU	0	DAC Volume Update Writing a 1 to this bit causes left and right DAC volume to be updated simultaneously	
	7:0	DACR_VOL [7:0]	1100_0000	Right DAC Digital Volume 00h = Mute 01h = -71.625dB 02h = -71.250dB ... (0.375dB steps) C0h to FFh = 0dB	

Register 1Fh DAC Digital Volume Right

REGISTER ADDRESS	BIT	LABEL	DEFAULT	DESCRIPTION	REFER TO
R33 (21h) DAC Digital 1	12	DAC_MONO	0	DAC Mono Mix 0 = Stereo 1 = Mono (Mono mix output on enabled DAC)	
	11	DAC_SB_FILT	0	Selects DAC filter characteristics 0 = Normal mode 1 = Sloping stopband mode	
	10	DAC_MUTERATE	0	DAC Soft Mute Ramp Rate 0 = Fast ramp (fs/2, maximum ramp time is 10.7ms at fs=48k) 1 = Slow ramp (fs/32, maximum ramp time is 171ms at fs=48k)	
	9	DAC_UNMUTE_RAMP	0	DAC Soft Mute Mode 0 = Disabling soft-mute (DAC_MUTE=0) will cause the DAC volume to change immediately to DACL_VOL and DACR_VOL settings 1 = Disabling soft-mute (DAC_MUTE=0) will cause the DAC volume to ramp up gradually to the DACL_VOL and DACR_VOL settings	
	6	DAC_OSR128	0	DAC Oversample Rate Select 0 = Low power (normal OSR) 1 = High performance (double OSR)	
	3	DAC_MUTE	1	DAC Soft Mute Control 0 = DAC Un-mute 1 = DAC Mute	
	2:1	DEEMPH [1:0]	00	DAC De-Emphasis Control 00 = No de-emphasis 01 = 32kHz sample rate 10 = 44.1kHz sample rate 11 = 48kHz sample rate	

Register 21h DAC Digital 1

REGISTER ADDRESS	BIT	LABEL	DEFAULT	DESCRIPTION	REFER TO
R40 (28h) DRC 0	15	DRC_ENA	0	DRC enable 1 = enabled 0 = disabled	
	14	DRC_DAC_PATH	0	DRC path select 0 = Reserved 1 = DAC path	
	12:11	DRC_GS_HYST_LVL [1:0]	00	Gain smoothing hysteresis threshold 00 = Low 01 = Medium (recommended) 10 = High 11 = Reserved	
	10:6	DRC_STARTUP_GAIN [4:0]	0_0110	Initial gain at DRC startup 00000 = -3dB 00001 = -2.5dB 00010 = -2dB 00011 = -1.5dB 00100 = -1dB 00101 = -0.5dB 00110 = 0dB (default) 00111 = 0.5dB 01000 = 1dB 01001 = 1.5dB 01010 = 2dB 01011 = 2.5dB 01100 = 3dB 01101 = 3.5dB 01110 = 4dB 01111 = 4.5dB 10000 = 5dB 10001 = 5.5dB 10010 = 6dB 10011 to 11111 = Reserved	
	5	DRC_FF_DELAY	1	Feed-forward delay for anti-clip feature 0 = 5 samples 1 = 9 samples Time delay can be calculated as $5/f_s$ or $9/f_s$, where f_s is the sample rate.	
	3	DRC_GS_ENA	1	Gain smoothing enable 0 = disabled 1 = enabled	
	2	DRC_QR	1	Quick release enable 0 = disabled 1 = enabled	
	1	DRC_ANTICLIP	1	Anti-clip enable 0 = disabled 1 = enabled	
	0	DRC_GS_HYST	1	Gain smoothing hysteresis enable 0 = disabled 1 = enabled	

Register 28h DRC 0

REGISTER ADDRESS	BIT	LABEL	DEFAULT	DESCRIPTION	REFER TO
R41 (29h) DRC 1	15:12	DRC_ATK [3:0]	0011	Gain attack rate (seconds/6dB) 0000 = instantaneous 0001 = 363us 0010 = 726us 0011 = 1.45ms (default) 0100 = 2.9ms 0101 = 5.8ms 0110 = 11.6ms 0111 = 23.2ms 1000 = 46.4ms 1001 = 92.8ms 1010 = 185.6ms 1011-1111 = Reserved	
	11:8	DRC_DCY [3:0]	0010	Gain decay rate (seconds/6dB) 0000 = 186ms 0001 = 372ms 0010 = 743ms (default) 0011 = 1.49s 0100 = 2.97s 0101 = 5.94s 0110 = 11.89s 0111 = 23.78s 1000 = 47.56s 1001-1111 = Reserved	
	7:6	DRC_QR_THR [1:0]	01	Quick release crest factor threshold 00 = 12dB 01 = 18dB (default) 10 = 24dB 11 = 30dB	
	5:4	DRC_QR_DCY [1:0]	00	Quick release decay rate (seconds/6dB) 00 = 0.725ms (default) 01 = 1.45ms 10 = 5.8ms 11 = Reserved	
	3:2	DRC_MINGAIN [1:0]	10	Minimum gain the DRC can use to attenuate audio signals 00 = 0dB (default) 01 = -6dB 10 = -12dB 11 = -18dB	
	1:0	DRC_MAXGAIN [1:0]	00	Maximum gain the DRC can use to boost audio signals 00 = 12dB 01 = 18dB (default) 10 = 24dB 11 = 36dB	

Register 29h DRC 1

REGISTER ADDRESS	BIT	LABEL	DEFAULT	DESCRIPTION	REFER TO
R42 (2Ah) DRC 2	5:3	DRC_HI_COM P [2:0]	000	Compressor slope R0 000 = 1 (no compression) 001 = 1/2 010 = 1/4 011 = 1/8 100 = 1/16 101 = 0 110 = Reserved 111 = Reserved	
	2:0	DRC_LO_COM P [2:0]	000	Compressor slope R1 000 = 1 (no compression) 001 = 1/2 010 = 1/4 011 = 1/8 100 = 0 101 = Reserved 11X = Reserved	

Register 2Ah DRC 2

REGISTER ADDRESS	BIT	LABEL	DEFAULT	DESCRIPTION	REFER TO
R43 (2Bh) DRC 3	10:5	DRC_KNEE_IP [5:0]	00_0000	Compressor threshold T (dB) 000000 = 0dB 000001 = -0.75dB 000010 = -1.5dB ... (-0.75dB steps) 111100 = -45dB 111101 = Reserved 11111X = Reserved	
	4:0	DRC_KNEE_OP [4:0]	0_0000	Compressor amplitude at threshold YT (dB) 00000 = 0dB 00001 = -0.75dB 00010 = -1.5dB ... (-0.75dB steps) 11110 = -22.5dB 11111 = Reserved	

Register 2Bh DRC 3

REGISTER ADDRESS	BIT	LABEL	DEFAULT	DESCRIPTION	REFER TO
R57 (39h) Analogue OUT1 Left	8	HPOUTL_MUTE	0	Left Headphone Output Mute 0 = Un-mute 1 = Mute	
	7	HPOUT_VU	0	Headphone Output Volume Update Writing a 1 to this bit will update HPOUTL and HPOUTR volumes simultaneously.	
	6	HPOUTLZC	0	Left Headphone Output Zero Cross Enable 0 = disabled 1 = enabled	
	5:0	HPOUTL_VOL [5:0]	10_1101	Left Headphone Output Volume 000000 = -57dB 000001 = -56dB (... 1dB steps) 111001 = 0dB (... 1dB steps) 111110 = +5dB 111111 = +6dB	

Register 39h Analogue OUT1 Left

REGISTER ADDRESS	BIT	LABEL	DEFAULT	DESCRIPTION	REFER TO
R58 (3Ah) Analogue OUT1 Right	8	HPOUTR_MUTE	0	Right Headphone Output Mute 0 = Un-mute 1 = Mute	
	7	HPOUT_VU	0	Headphone Output Volume Update Writing a 1 to this bit will update HPOUTL and HPOUTR volumes simultaneously.	
	6	HPOUTRZC	0	Right Headphone Output Zero Cross Enable 0 = disabled 1 = enabled	
	5:0	HPOUTR_VOL [5:0]	10_1101	Right Headphone Output Volume 000000 = -57dB 000001 = -56dB (... 1dB steps) 111001 = 0dB (... 1dB steps) 111110 = +5dB 111111 = +6dB	

Register 3Ah Analogue OUT1 Right

REGISTER ADDRESS	BIT	LABEL	DEFAULT	DESCRIPTION	REFER TO
R59 (3Bh) Analogue OUT2 Left	8	LINEOUTL_MUTE	0	Left Line Output Mute 0 = Un-mute 1 = Mute	
	7	LINEOUT_VU	0	Line Output Volume Update Writing a 1 to this bit will update LINEOUTL and LINEOUTR volumes simultaneously.	
	6	LINEOUTLZC	0	Left Line Output Zero Cross Enable 0 = disabled 1 = enabled	
	5:0	LINEOUTL_VOLUME [5:0]	11_1001	Left Line Output Volume 000000 = -57dB 000001 = -56dB (... 1dB steps) 111001 = 0dB (... 1dB steps) 111110 = +5dB 111111 = +6dB	

Register 3Bh Analogue OUT2 Left

REGISTER ADDRESS	BIT	LABEL	DEFAULT	DESCRIPTION	REFER TO
R60 (3Ch) Analogue OUT2 Right	8	LINEOUTR_MUTE	0	Right Line Output Mute 0 = Un-mute 1 = Mute	
	7	LINEOUT_VU	0	Line Output Volume Update Writing a 1 to this bit will update LINEOUTL and LINEOUTR volumes simultaneously.	
	6	LINEOUTRZC	0	Right Line Output Zero Cross Enable 0 = disabled 1 = enabled	
	5:0	LINEOUTR_VOLUME [5:0]	11_1001	Right Line Output Volume 000000 = -57dB 000001 = -56dB (... 1dB steps) 111001 = 0dB (... 1dB steps) 111110 = +5dB 111111 = +6dB	

Register 3Ch Analogue OUT2 Right

REGISTER ADDRESS	BIT	LABEL	DEFAULT	DESCRIPTION	REFER TO
R67 (43h) DC Servo 0	3	DCS_ENA_CH AN_3	0	DC Servo enable for LINEOUTR 0 = disabled 1 = enabled	
	2	DCS_ENA_CH AN_2	0	DC Servo enable for LINEOUTL 0 = disabled 1 = enabled	
	1	DCS_ENA_CH AN_1	0	DC Servo enable for HPOUTR 0 = disabled 1 = enabled	
	0	DCS_ENA_CH AN_0	0	DC Servo enable for HPOUTL 0 = disabled 1 = enabled	

Register 43h DC Servo 0

REGISTER ADDRESS	BIT	LABEL	DEFAULT	DESCRIPTION	REFER TO
R68 (44h) DC Servo 1	15	DCS_TRIG_SI NGLE_3	0	Writing 1 to this bit selects a single DC offset correction for LINEOUTR. In readback, a value of 1 indicates that the DC Servo single correction is in progress.	
	14	DCS_TRIG_SI NGLE_2	0	Writing 1 to this bit selects a single DC offset correction for LINEOUTL. In readback, a value of 1 indicates that the DC Servo single correction is in progress.	
	13	DCS_TRIG_SI NGLE_1	0	Writing 1 to this bit selects a single DC offset correction for HPOUTR. In readback, a value of 1 indicates that the DC Servo single correction is in progress.	
	12	DCS_TRIG_SI NGLE_0	0	Writing 1 to this bit selects a single DC offset correction for HPOUTL. In readback, a value of 1 indicates that the DC Servo single correction is in progress.	
	11	DCS_TRIG_SE RIES_3	0	Writing 1 to this bit selects a series of DC offset corrections for LINEOUTR. In readback, a value of 1 indicates that the DC Servo DAC Write correction is in progress.	
	10	DCS_TRIG_SE RIES_2	0	Writing 1 to this bit selects a series of DC offset corrections for LINEOUTL. In readback, a value of 1 indicates that the DC Servo DAC Write correction is in progress.	
	9	DCS_TRIG_SE RIES_1	0	Writing 1 to this bit selects a series of DC offset corrections for HPOUTR. In readback, a value of 1 indicates that the DC Servo DAC Write correction is in progress.	
	8	DCS_TRIG_SE RIES_0	0	Writing 1 to this bit selects a series of DC offset corrections for HPOUTL. In readback, a value of 1 indicates that the DC Servo DAC Write correction is in progress.	
	7	DCS_TRIG_ST ARTUP_3	0	Writing 1 to this bit selects Start-Up DC Servo mode for LINEOUTR. In readback, a value of 1 indicates that the DC Servo Start-Up correction is in progress.	
	6	DCS_TRIG_ST ARTUP_2	0	Writing 1 to this bit selects Start-Up DC Servo mode for LINEOUTL.	

REGISTER ADDRESS	BIT	LABEL	DEFAULT	DESCRIPTION	REFER TO
				In readback, a value of 1 indicates that the DC Servo Start-Up correction is in progress.	
	5	DCS_TRIG_ST ARTUP_1	0	Writing 1 to this bit selects Start-Up DC Servo mode for HPOUTR. In readback, a value of 1 indicates that the DC Servo Start-Up correction is in progress.	
	4	DCS_TRIG_ST ARTUP_0	0	Writing 1 to this bit selects Start-Up DC Servo mode for HPOUTL. In readback, a value of 1 indicates that the DC Servo Start-Up correction is in progress.	
	3	DCS_TRIG_DA C_WR_3	0	Writing 1 to this bit selects DAC Write DC Servo mode for LINEOUTR. In readback, a value of 1 indicates that the DC Servo DAC Write correction is in progress.	
	2	DCS_TRIG_DA C_WR_2	0	Writing 1 to this bit selects DAC Write DC Servo mode for LINEOUTL. In readback, a value of 1 indicates that the DC Servo DAC Write correction is in progress.	
	1	DCS_TRIG_DA C_WR_1	0	Writing 1 to this bit selects DAC Write DC Servo mode for HPOUTR. In readback, a value of 1 indicates that the DC Servo DAC Write correction is in progress.	
	0	DCS_TRIG_DA C_WR_0	0	Writing 1 to this bit selects DAC Write DC Servo mode for HPOUTL. In readback, a value of 1 indicates that the DC Servo DAC Write correction is in progress.	

Register 44h DC Servo 1

REGISTER ADDRESS	BIT	LABEL	DEFAULT	DESCRIPTION	REFER TO
R69 (45h) DC Servo 2	11:8	DCS_TIMER_P ERIOD_23 [3:0]	1010	Time between periodic updates for LINEOUTL/LINEOUTR. Time is calculated as $0.256s \times (2^{\text{PERIOD}})$ 0000 = Off 0001 = 0.52s 1010 = 266s (4min 26s) 1111 = 8519s (2hr 22s)	
	3:0	DCS_TIMER_P ERIOD_01 [3:0]	1010	Time between periodic updates for HPOUTL/HPOUTR. Time is calculated as $0.256s \times (2^{\text{PERIOD}})$ 0000 = Off 0001 = 0.52s 1010 = 266s (4min 26s) 1111 = 8519s (2hr 22s)	

Register 45h DC Servo 2

REGISTER ADDRESS	BIT	LABEL	DEFAULT	DESCRIPTION	REFER TO
R71 (47h) DC Servo 4	6:0	DCS_SERIES_ NO_23 [6:0]	010_1010	Number of DC Servo updates to perform in a series event for LINEOUTL/LINEOUTR. 0 = 1 updates 1 = 2 updates ... 127 = 128 updates	

Register 47h DC Servo 4

REGISTER ADDRESS	BIT	LABEL	DEFAULT	DESCRIPTION	REFER TO
R72 (48h) DC Servo 5	6:0	DCS_SERIES_NO_01 [6:0]	010_1010	Number of DC Servo updates to perform in a series event for HPOUTL/HPOUTR. 0 = 1 updates 1 = 2 updates ... 127 = 128 updates	

Register 48h DC Servo 5

REGISTER ADDRESS	BIT	LABEL	DEFAULT	DESCRIPTION	REFER TO
R73 (49h) DC Servo 6	7:0	DCS_DAC_WR_VAL_3 [7:0]	0000_0000	DC Offset value for LINEOUTR in DAC Write DC Servo mode in two's complement format. In readback, the current DC offset value is returned in two's complement format. Two's complement format: LSB is 0.25mV. Range is +/-32mV	

Register 49h DC Servo 6

REGISTER ADDRESS	BIT	LABEL	DEFAULT	DESCRIPTION	REFER TO
R74 (4Ah) DC Servo 7	7:0	DCS_DAC_WR_VAL_2 [7:0]	0000_0000	DC Offset value for LINEOUTL in DAC Write DC Servo mode in two's complement format. In readback, the current DC offset value is returned in two's complement format. Two's complement format: LSB is 0.25mV. Range is +/-32mV	

Register 4Ah DC Servo 7

REGISTER ADDRESS	BIT	LABEL	DEFAULT	DESCRIPTION	REFER TO
R75 (4Bh) DC Servo 8	7:0	DCS_DAC_WR_VAL_1 [7:0]	0000_0000	DC Offset value for HPOUTR in DAC Write DC Servo mode in two's complement format. In readback, the current DC offset value is returned in two's complement format. Two's complement format: LSB is 0.25mV. Range is +/-32mV	

Register 4Bh DC Servo 8

REGISTER ADDRESS	BIT	LABEL	DEFAULT	DESCRIPTION	REFER TO
R76 (4Ch) DC Servo 9	7:0	DCS_DAC_WR_VAL_0 [7:0]	0000_0000	DC Offset value for HPOUTL in DAC Write DC Servo mode in two's complement format. In readback, the current DC offset value is returned in two's complement format. Two's complement format: LSB is 0.25mV. Range is +/-32mV	

Register 4Ch DC Servo 9

REGISTER ADDRESS	BIT	LABEL	DEFAULT	DESCRIPTION	REFER TO
R77 (4Dh) DC Servo Readback 0	11:8	DCS_CAL_COMPLETE [3:0]	0000	DC Servo Complete status [3] - LINEOUTR [2] - LINEOUTL [1] - HPOUTR [0] - HPOUTL 0 = DAC Write or Start-Up DC Servo mode not completed. 1 = DAC Write or Start-Up DC Servo mode complete.	
	7:4	DCS_DAC_WRITE_COMPLETE [3:0]	0000	DC Servo DAC Write status [3] - LINEOUTR [2] - LINEOUTL [1] - HPOUTR [0] - HPOUTL 0 = DAC Write DC Servo mode not completed. 1 = DAC Write DC Servo mode complete.	
	3:0	DCS_STARTUP_COMPLETE [3:0]	0000	DC Servo Start-Up status [3] - LINEOUTR [2] - LINEOUTL [1] - HPOUTR [0] - HPOUTL 0 = Start-Up DC Servo mode not completed.. 1 = Start-Up DC Servo mode complete.	

Register 4Dh DC Servo Readback 0

REGISTER ADDRESS	BIT	LABEL	DEFAULT	DESCRIPTION	REFER TO
R90 (5Ah) Analogue HP 0	7	HPL_RMV_SHORT	0	Removes HPOUTL short 0 = HPOUTL short enabled 1 = HPOUTL short removed For normal operation, this bit should be set as the final step of the HPL Enable sequence.	
	6	HPL_ENA_OUTP	0	Enables HPOUTL output stage 0 = Disabled 1 = Enabled For normal operation, this bit should be set to 1 after the DC offset cancellation has been scheduled.	
	5	HPL_ENA_DLY	0	Enables HPOUTL intermediate stage 0 = Disabled 1 = Enabled For normal operation, this bit should be set to 1 after the output signal path has been configured, and before DC offset cancellation is scheduled. This bit should be set with at least 20us delay after HPL_ENA.	
	4	HPL_ENA	0	Enables HPOUTL input stage 0 = Disabled 1 = Enabled For normal operation, this bit should be set as the first step of the HPL Enable sequence.	
	3	HPR_RMV_SHORT	0	Removes HPOUTR short 0 = HPOUTR short enabled 1 = HPOUTR short removed For normal operation, this bit should be set as the final step of the HPR Enable sequence.	
	2	HPR_ENA_OUTP	0	Enables HPOUTR output stage 0 = Disabled 1 = Enabled For normal operation, this bit should be set to 1 after the DC offset cancellation has been scheduled.	
	1	HPR_ENA_DLY	0	Enables HPOUTR intermediate stage 0 = Disabled 1 = Enabled For normal operation, this bit should be set to 1 after the output signal path has been configured, and before DC offset cancellation is scheduled. This bit should be set with at least 20us delay after HPR_ENA.	
	0	HPR_ENA	0	Enables HPOUTR input stage 0 = Disabled 1 = Enabled For normal operation, this bit should be set as the first step of the HPR Enable sequence.	

Register 5Ah Analogue HP 0

REGISTER ADDRESS	BIT	LABEL	DEFAULT	DESCRIPTION	REFER TO
R94 (5Eh) Analogue Lineout 0	7	LINEOUTL_RM V_SHORT	0	Removes LINEOUTL short 0 = LINEOUTL short enabled 1 = LINEOUTL short removed For normal operation, this bit should be set as the final step of the LINEOUTL Enable sequence.	
	6	LINEOUTL_EN A_OUTP	0	Enables LINEOUTL output stage 0 = Disabled 1 = Enabled For normal operation, this bit should be set to 1 after the DC offset cancellation has been scheduled.	
	5	LINEOUTL_EN A_DLY	0	Enables LINEOUTL intermediate stage 0 = Disabled 1 = Enabled For normal operation, this bit should be set to 1 after the output signal path has been configured, and before DC offset cancellation is scheduled. This bit should be set with at least 20us delay after LINEOUTL_ENA.	
	4	LINEOUTL_EN A	0	Enables LINEOUTL input stage 0 = Disabled 1 = Enabled For normal operation, this bit should be set as the first step of the LINEOUTL Enable sequence.	
	3	LINEOUTR_R MV_SHORT	0	Removes LINEOUTR short 0 = LINEOUTR short enabled 1 = LINEOUTR short removed For normal operation, this bit should be set as the final step of the LINEOUTR Enable sequence.	
	2	LINEOUTR_EN A_OUTP	0	Enables LINEOUTR output stage 0 = Disabled 1 = Enabled For normal operation, this bit should be set to 1 after the DC offset cancellation has been scheduled.	
	1	LINEOUTR_EN A_DLY	0	Enables LINEOUTR intermediate stage 0 = Disabled 1 = Enabled For normal operation, this bit should be set to 1 after the output signal path has been configured, and before DC offset cancellation is scheduled. This bit should be set with at least 20us delay after LINEOUTR_ENA.	
	0	LINEOUTR_EN A	0	Enables LINEOUTR input stage 0 = Disabled 1 = Enabled For normal operation, this bit should be set as the first step of the LINEOUTR Enable sequence.	

Register 5Eh Analogue Lineout 0

REGISTER ADDRESS	BIT	LABEL	DEFAULT	DESCRIPTION	REFER TO
R98 (62h) Charge Pump 0	0	CP_ENA	0	Enable charge-pump digits 0 = disable 1 = enable	

Register 62h Charge Pump 0

REGISTER ADDRESS	BIT	LABEL	DEFAULT	DESCRIPTION	REFER TO
R104 (68h) Class W 0	0	CP_DYN_PWR	0	Enable dynamic charge pump power control 0 = Charge pump controlled by volume register settings (Class G) 1 = Charge pump controlled by real-time audio level (Class W) Class W is recommended for lowest power consumption.	

Register 68h Class W 0

REGISTER ADDRESS	BIT	LABEL	DEFAULT	DESCRIPTION	REFER TO
R108 (6Ch) Write Sequencer 0	8	WSEQ_ENA	0	Write Sequencer Enable. 0 = Disabled 1 = Enabled	
	4:0	WSEQ_WRITE_INDEX [4:0]	0_0000	Sequence Write Index. This is the memory location to which any updates to R109 and R110 will be copied. 0 to 31 = RAM addresses	

Register 6Ch Write Sequencer 0

REGISTER ADDRESS	BIT	LABEL	DEFAULT	DESCRIPTION	REFER TO
R109 (6Dh) Write Sequencer 1	14:12	WSEQ_DATA_WIDTH [2:0]	000	Width of the data block written in this sequence step. 000 = 1 bit 001 = 2 bits 010 = 3 bits 011 = 4 bits 100 = 5 bits 101 = 6 bits 110 = 7 bits 111 = 8 bits	
	11:8	WSEQ_DATA_START [3:0]	0000	Bit position of the LSB of the data block written in this sequence step. 0000 = Bit 0 ... 1111 = Bit 15	
	7:0	WSEQ_ADDR [7:0]	0000_0000	Control Register Address to be written to in this sequence step.	

Register 6Dh Write Sequencer 1

REGISTER ADDRESS	BIT	LABEL	DEFAULT	DESCRIPTION	REFER TO
R110 (6Eh) Write Sequencer 2	14	WSEQ_EOS	0	End of Sequence flag. This bit indicates whether the Control Write Sequencer should stop after executing this step. 0 = Not end of sequence 1 = End of sequence (Stop the sequencer after this step).	
	11:8	WSEQ_DELAY [3:0]	0000	Time delay after executing this step. Total delay time per step (including execution)= $62.5\mu\text{s} \times (2^{\text{WSEQ_DELAY}} + 8)$	
	7:0	WSEQ_DATA [7:0]	0000_0000	Data to be written in this sequence step. When the data width is less than 8 bits, then one or more of the MSBs of WSEQ_DATA are ignored. It is recommended that unused bits be set to 0.	

Register 6Eh Write Sequencer 2

REGISTER ADDRESS	BIT	LABEL	DEFAULT	DESCRIPTION	REFER TO
R111 (6Fh) Write Sequencer 3	9	WSEQ_ABORT	0	Writing a 1 to this bit aborts the current sequence and returns control of the device back to the serial control interface.	
	8	WSEQ_START	0	Writing a 1 to this bit starts the write sequencer at the memory location indicated by the WSEQ_START_INDEX field. The sequence continues until it reaches an "End of sequence" flag. At the end of the sequence, this bit will be reset by the Write Sequencer.	
	5:0	WSEQ_START_INDEX [5:0]	00_0000	Sequence Start Index. This is the memory location of the first command in the selected sequence. 0 to 31 = RAM addresses 32 to 48 = ROM addresses 49 to 63 = Reserved	

Register 6Fh Write Sequencer 3

REGISTER ADDRESS	BIT	LABEL	DEFAULT	DESCRIPTION	REFER TO
R112 (70h) Write Sequencer 4	9:4	WSEQ_CURRENT_INDEX [5:0]	00_0000	Sequence Current Index (read only): This is the location of the most recently accessed command in the write sequencer memory.	
	0	WSEQ_BUSY	0	Sequencer Busy flag (read only): 0 = Sequencer idle 1 = Sequencer busy Note: it is not possible to write to control registers via the control interface while the Sequencer is Busy.	

Register 70h Write Sequencer 4

REGISTER ADDRESS	BIT	LABEL	DEFAULT	DESCRIPTION	REFER TO
R116 (74h) FLL Control 1	2	FLL_FRACN_ENA	0	FLL Fractional enable 0 = Integer Mode 1 = Fractional Mode Fractional Mode (FLL_FRACN_ENA=1) is recommended in all cases	
	1	FLL_OSC_ENA	0	FLL Oscillator enable 0 = Disabled 1 = Enabled FLL_OSC_ENA must be enabled before enabling FLL_ENA. Note that this field is required for free-running FLL modes only.	
	0	FLL_ENA	0	FLL Enable 0 = Disabled 1 = Enabled FLL_OSC_ENA must be enabled before enabling FLL_ENA.	

Register 74h FLL Control 1

REGISTER ADDRESS	BIT	LABEL	DEFAULT	DESCRIPTION	REFER TO
R117 (75h) FLL Control 2	13:8	FLL_OUTDIV [5:0]	00_0000	FLL FOUT clock divider 00_0000 = Reserved 00_0001 = Reserved 00_0010 = Reserved 00_0011 = 4 00_0100 = 5 00_0101 = 6 ... 11_1110 = 63 11_1111 = 64 (FOUT = FVCO / FLL_OUTDIV)	
	6:4	FLL_CTRL_RATE [2:0]	000	Frequency of the FLL control block 000 = FVCO / 1 (Recommended value) 001 = FVCO / 2 010 = FVCO / 3 011 = FVCO / 4 100 = FVCO / 5 101 = FVCO / 6 110 = FVCO / 7 111 = FVCO / 8 Recommended that these are not changed from default.	
	2:0	FLL_FRATIO [2:0]	111	FVCO clock divider 000 = 1 001 = 2 010 = 4	

REGISTER ADDRESS	BIT	LABEL	DEFAULT	DESCRIPTION	REFER TO
				011 = 8 1XX = 16 000 recommended for high FREF 011 recommended for low FREF	

Register 75h FLL Control 2

REGISTER ADDRESS	BIT	LABEL	DEFAULT	DESCRIPTION	REFER TO
R118 (76h) FLL Control 3	15:0	FLL_K [15:0]	0000_0000 _0000_000 0	Fractional multiply for FREF (MSB = 0.5)	

Register 76h FLL Control 3

REGISTER ADDRESS	BIT	LABEL	DEFAULT	DESCRIPTION	REFER TO
R119 (77h) FLL Control 4	14:5	FLL_N [9:0]	01_0111_0 111	Integer multiply for FREF (LSB = 1)	
	3:0	FLL_GAIN [3:0]	0000	FLL Gain applied to error 0000 = x 1 (Recommended value) 0001 = x 2 0010 = x 4 0011 = x 8 0100 = x 16 0101 = x 32 0110 = x 64 0111 = x 128 1000 = x 256 Recommended that these are not changed from default.	

Register 77h FLL Control 4

REGISTER ADDRESS	BIT	LABEL	DEFAULT	DESCRIPTION	REFER TO
R120 (78h) FLL Control 5	4:3	FLL_CLK_REF_DIV [1:0]	00	FLL Clock Reference Divider 00 = MCLK / 1 01 = MCLK / 2 10 = MCLK / 4 11 = MCLK / 8 MCLK (or other input reference) must be divided down to <=13.5MHz. For lower power operation, the reference clock can be divided down further if desired.	
	1:0	FLL_CLK_REF_SRC [1:0]	00	FLL Clock source 00 = MCLK 01 = BCLK 10 = LRCLK	

REGISTER ADDRESS	BIT	LABEL	DEFAULT	DESCRIPTION	REFER TO
				11 = Reserved	

Register 78h FLL Control 5

REGISTER ADDRESS	BIT	LABEL	DEFAULT	DESCRIPTION	REFER TO
R121 (79h) GPIO Control 1	5	GPIO1_PU	0	GPIO1 pull-up resistor enable 0 = pull-up disabled 1 = pull-up enabled	
	4	GPIO1_PD	1	GPIO1 pull-down resistor enable 0 = pull-down disabled 1 = pull-down enabled	
	3:0	GPIO1_SEL [3:0]	0100	GPIO1 Function Select 0000 = GPIO input 0001 = Clock output (f=SYSCLK/OPCLKDIV) 0010 = Logic '0' output 0011 = Logic '1' output 0100 = IRQ output (default) 0101 = FLL Lock output 0110 = Reserved 0111 = Reserved 1000 = Reserved 1001 = FLL Clock output 1010 to 1111 = Reserved	

Register 79h GPIO Control 1

REGISTER ADDRESS	BIT	LABEL	DEFAULT	DESCRIPTION	REFER TO
R124 (7Ch) GPIO Control 4	7	GPIO_BCLK_ MODE_ENA	0	Selects BCLK/GPIO4 pin function 0 = BCLK/GPIO4 is used as BCLK 1 = BCLK/GPIO4 is used as GPIO. MCLK provides the BCLK in the AIF in this mode.	
	3:0	GPIO_BCLK_S EL [3:0]	0000	BCLK/GPIO4 function select: 0000 = GPIO input (default) 0001 = Clock output (f=SYSCLK/OPCLKDIV) 0010 = Logic '0' output 0011 = Logic '1' output 0100 = IRQ output 0101 = FLL Lock output 0110 = Reserved 0111 = Reserved 1000 = Reserved 1001 = FLL Clock output 1010 to 1111 = Reserved	

Register 7Ch GPIO Control 4

REGISTER ADDRESS	BIT	LABEL	DEFAULT	DESCRIPTION	REFER TO
R126 (7Eh) Digital Pulls	7	MCLK_PU	0	MCLK pull-up resistor enable 0 = pull-up disabled 1 = pull-up enabled	
	6	MCLK_PD	0	MCLK pull-down resistor enable 0 = pull-down disabled 1 = pull-down enabled	
	5	DACDAT_PU	0	DACDAT pull-up resistor enable 0 = pull-up disabled 1 = pull-up enabled	
	4	DACDAT_PD	0	DACDAT pull-down resistor enable 0 = pull-down disabled 1 = pull-down enabled	
	3	LRCLK_PU	0	LRCLK pull-up resistor enable 0 = pull-up disabled 1 = pull-up enabled	
	2	LRCLK_PD	0	LRCLK pull-down resistor enable 0 = pull-down disabled 1 = pull-down enabled	
	1	BCLK_PU	0	BCLK pull-up resistor enable 0 = pull-up disabled 1 = pull-up enabled	
	0	BCLK_PD	0	BCLK pull-down resistor enable 0 = pull-down disabled 1 = pull-down enabled	

Register 7Eh Digital Pulls

REGISTER ADDRESS	BIT	LABEL	DEFAULT	DESCRIPTION	REFER TO
R127 (7Fh) Interrupt Status	10	IRQ	0	Logical OR of all other interrupt flags	
	9	GPIO_BCLK_EINT	0	GPIO4 interrupt 0 = interrupt not set 1 = interrupt is set Cleared when a '1' is written	
	8	WSEQ_EINT	0	Write Sequence interrupt 0 = interrupt not set 1 = interrupt is set Cleared when a '1' is written. Note that the read value of WSEQ_EINT is not valid whilst the Write Sequencer is Busy	
	5	GPIO1_EINT	0	GPIO1 interrupt 0 = interrupt not set 1 = interrupt is set Cleared when a '1' is written	
	2	FLL_LOCK_EINT	0	FLL Lock interrupt 0 = interrupt not set 1 = interrupt is set Cleared when a '1' is written	

Register 7Fh Interrupt Status

REGISTER ADDRESS	BIT	LABEL	DEFAULT	DESCRIPTION	REFER TO
R128 (80h) Interrupt Status Mask	9	IM_GPIO_BCLK_EINT	1	GPIO4 interrupt mask 0 = do not mask interrupt 1 = mask interrupt	
	8	IM_WSEQ_EINT	1	Write sequencer interrupt mask 0 = do not mask interrupt 1 = mask interrupt	
	5	IM_GPIO1_EINT	1	GPIO1 interrupt mask 0 = do not mask interrupt 1 = mask interrupt	
	2	IM_FLL_LOCK_EINT	1	FLL Lock interrupt mask 0 = do not mask interrupt 1 = mask interrupt	

Register 80h Interrupt Status Mask

REGISTER ADDRESS	BIT	LABEL	DEFAULT	DESCRIPTION	REFER TO
R129 (81h) Interrupt Polarity	9	GPIO_BCLK_EINT_POL	0	GPIO4 interrupt polarity 0 = active high 1 = active low	
	8	WSEQ_EINT_POL	0	Write Sequencer interrupt polarity 0 = active high (interrupt is triggered when WSEQ is busy) 1 = active low (interrupt is triggered when WSEQ is idle)	
	5	GPIO1_EINT_POL	0	GPIO1 interrupt polarity 0 = active high 1 = active low	
	2	FLL_LOCK_EINT_POL	0	FLL Lock interrupt polarity 0 = active high (interrupt is triggered when FLL Lock is reached) 1 = active low (interrupt is triggered when FLL is not locked)	

Register 81h Interrupt Polarity

REGISTER ADDRESS	BIT	LABEL	DEFAULT	DESCRIPTION	REFER TO
R130 (82h) Interrupt Debounce	9	GPIO_BCLK_EINT_DB	0	GPIO4 interrupt debounce 0 = disabled 1 = enabled	
	8	WSEQ_EINT_DB	0	Write Sequencer interrupt debounce enable 0 = disabled 1 = enabled	
	5	GPIO1_EINT_DB	0	GPIO1 input debounce 0 = disabled 1 = enabled	
	2	FLL_LOCK_EINT_DB	0	FLL Lock debounce 0 = disabled 1 = enabled	

Register 82h Interrupt Debounce

REGISTER ADDRESS	BIT	LABEL	DEFAULT	DESCRIPTION	REFER TO
R134 (86h) EQ1	0	EQ_ENA	0	EQ enable 0 = EQ disabled 1 = EQ enabled	

Register 86h EQ1

REGISTER ADDRESS	BIT	LABEL	DEFAULT	DESCRIPTION	REFER TO
R135 (87h) EQ2	4:0	EQ_B1_GAIN [4:0]	0_1100	Gain for EQ band 1 00000 = -12dB 00001 = -11dB (... 1dB steps) 01100 = 0dB (... 1dB steps) 11000 = +12dB 11001 to 11111 = reserved	

Register 87h EQ2

REGISTER ADDRESS	BIT	LABEL	DEFAULT	DESCRIPTION	REFER TO
R136 (88h) EQ3	4:0	EQ_B2_GAIN [4:0]	0_1100	Gain for EQ band 2 00000 = -12dB 00001 = -11dB (... 1dB steps) 01100 = 0dB (... 1dB steps) 11000 = +12dB 11001 to 11111 = reserved	

Register 88h EQ3

REGISTER ADDRESS	BIT	LABEL	DEFAULT	DESCRIPTION	REFER TO
R137 (89h) EQ4	4:0	EQ_B3_GAIN [4:0]	0_1100	Gain for EQ band 3 00000 = -12dB 00001 = -11dB (... 1dB steps) 01100 = 0dB (... 1dB steps) 11000 = +12dB 11001 to 11111 = reserved	

Register 89h EQ4

REGISTER ADDRESS	BIT	LABEL	DEFAULT	DESCRIPTION	REFER TO
R138 (8Ah) EQ5	4:0	EQ_B4_GAIN [4:0]	0_1100	Gain for EQ band 4 00000 = -12dB 00001 = -11dB (... 1dB steps) 01100 = 0dB (... 1dB steps) 11000 = +12dB 11001 to 11111 = reserved	

Register 8Ah EQ5

REGISTER ADDRESS	BIT	LABEL	DEFAULT	DESCRIPTION	REFER TO
R139 (8Bh) EQ6	4:0	EQ_B5_GAIN [4:0]	0_1100	Gain for EQ band5 00000 = -12dB 00001 = -11dB (... 1dB steps) 01100 = 0dB (... 1dB steps) 11000 = +12dB 11001 to 11111 = reserved	

Register 8Bh EQ6

REGISTER ADDRESS	BIT	LABEL	DEFAULT	DESCRIPTION	REFER TO
R140 (8Ch) EQ7	15:0	EQ_B1_A [15:0]	0000_1111 _1100_101 0	EQ Band 1 Coefficient A	

Register 8Ch EQ7

REGISTER ADDRESS	BIT	LABEL	DEFAULT	DESCRIPTION	REFER TO
R141 (8Dh) EQ8	15:0	EQ_B1_B [15:0]	0000_0100 _0000_000 0	EQ Band 1 Coefficient B	

Register 8Dh EQ8

REGISTER ADDRESS	BIT	LABEL	DEFAULT	DESCRIPTION	REFER TO
R142 (8Eh) EQ9	15:0	EQ_B1_PG [15:0]	0000_0000 _1101_100 0	EQ Band 1 Coefficient PG	

Register 8Eh EQ9

REGISTER ADDRESS	BIT	LABEL	DEFAULT	DESCRIPTION	REFER TO
R143 (8Fh) EQ10	15:0	EQ_B2_A [15:0]	0001_1110 _1011_010 1	EQ Band 2 Coefficient A	

Register 8Fh EQ10

REGISTER ADDRESS	BIT	LABEL	DEFAULT	DESCRIPTION	REFER TO
R144 (90h) EQ11	15:0	EQ_B2_B [15:0]	1111_0001 _0100_010 1	EQ Band 2 Coefficient B	

Register 90h EQ11

REGISTER ADDRESS	BIT	LABEL	DEFAULT	DESCRIPTION	REFER TO
R145 (91h) EQ12	15:0	EQ_B2_C [15:0]	0000_1011 _0111_010 1	EQ Band 2 Coefficient C	

Register 91h EQ12

REGISTER ADDRESS	BIT	LABEL	DEFAULT	DESCRIPTION	REFER TO
R146 (92h) EQ13	15:0	EQ_B2_PG [15:0]	0000_0001 _1100_010 1	EQ Band 2 Coefficient PG	

Register 92h EQ13

REGISTER ADDRESS	BIT	LABEL	DEFAULT	DESCRIPTION	REFER TO
R147 (93h) EQ14	15:0	EQ_B3_A [15:0]	0001_1100 _0101_100 0	EQ Band 3 Coefficient A	

Register 93h EQ14

REGISTER ADDRESS	BIT	LABEL	DEFAULT	DESCRIPTION	REFER TO
R148 (94h) EQ15	15:0	EQ_B3_B [15:0]	1111_0011 _0111_001 1	EQ Band 3 Coefficient B	

Register 94h EQ15

REGISTER ADDRESS	BIT	LABEL	DEFAULT	DESCRIPTION	REFER TO
R149 (95h) EQ16	15:0	EQ_B3_C [15:0]	0000_1010 _0101_010 0	EQ Band 3 Coefficient C	

Register 95h EQ16

REGISTER ADDRESS	BIT	LABEL	DEFAULT	DESCRIPTION	REFER TO
R150 (96h) EQ17	15:0	EQ_B3_PG [15:0]	0000_0101 _0101_100 0	EQ Band 3 Coefficient PG	

Register 96h EQ17

REGISTER ADDRESS	BIT	LABEL	DEFAULT	DESCRIPTION	REFER TO
R151 (97h) EQ18	15:0	EQ_B4_A [15:0]	0001_0110 _1000_111 0	EQ Band 4 Coefficient A	

Register 97h EQ18

REGISTER ADDRESS	BIT	LABEL	DEFAULT	DESCRIPTION	REFER TO
R152 (98h) EQ19	15:0	EQ_B4_B [15:0]	1111_1000 _0010_100 1	EQ Band 4 Coefficient B	

Register 98h EQ19

REGISTER ADDRESS	BIT	LABEL	DEFAULT	DESCRIPTION	REFER TO
R153 (99h) EQ20	15:0	EQ_B4_C [15:0]	0000_0111 _1010_110 1	EQ Band 4 Coefficient C	

Register 99h EQ20

REGISTER ADDRESS	BIT	LABEL	DEFAULT	DESCRIPTION	REFER TO
R154 (9Ah) EQ21	15:0	EQ_B4_PG [15:0]	0001_0001 _0000_001 1	EQ Band 4 Coefficient PG	

Register 9Ah EQ21

REGISTER ADDRESS	BIT	LABEL	DEFAULT	DESCRIPTION	REFER TO
R155 (9Bh) EQ22	15:0	EQ_B5_A [15:0]	0000_0101 _0110_010 0	EQ Band 5 Coefficient A	

Register 9Bh EQ22

REGISTER ADDRESS	BIT	LABEL	DEFAULT	DESCRIPTION	REFER TO
R156 (9Ch) EQ23	15:0	EQ_B5_B [15:0]	0000_0101 _0101_100 1	EQ Band 1 Coefficient B	

Register 9Ch EQ23

REGISTER ADDRESS	BIT	LABEL	DEFAULT	DESCRIPTION	REFER TO
R157 (9Dh) EQ24	15:0	EQ_B5_PG [15:0]	0100_0000 _0000_000 0	EQ Band 5 Coefficient PG	

Register 9Dh EQ24

REGISTER ADDRESS	BIT	LABEL	DEFAULT	DESCRIPTION	REFER TO
R247 (F7h) FLL NCO Test 0	0	FLL_FRC_NC O	0	FLL Forced control select 0 = Normal 1 = FLL oscillator controlled by FLL_FRC_NCO_VAL (Note that this field is required for free-running FLL modes only)	

Register F7h FLL NCO Test 0

REGISTER ADDRESS	BIT	LABEL	DEFAULT	DESCRIPTION	REFER TO
R248 (F8h) FLL NCO Test 1	5:0	FLL_FRC_NC O_VAL [5:0]	01_1001	FLL Forced oscillator value Valid range is 000000 to 111111 0x19h (011001) = 12MHz approx (Note that this field is required for free-running FLL modes only)	

Register F8h FLL NCO Test 1

APPLICATIONS INFORMATION

RECOMMENDED EXTERNAL COMPONENTS

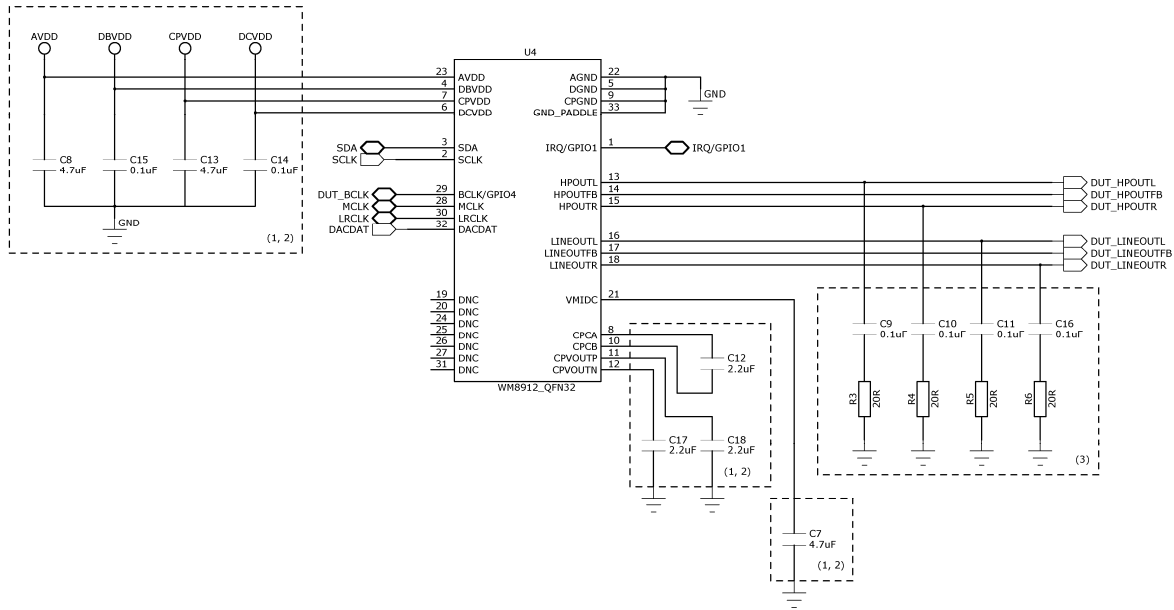

Figure 56 Recommended External Components

Notes:

1. Decoupling Capacitors

X5R ceramic capacitor is recommended for capacitors C7, C8, C13, C14, C15, C17 and C18.

The positioning of C7 is very important - this should be as close to the WM8912 as possible.

Capacitors C17 and C18 should also be positioned as close to the WM8912 as possible.

2. Charge Pump Capacitors

Specific recommendations for C12, C17 and C18 are provided in Table 66. Note that two different recommendations are provided for C17 and C18; either of these components is suitable, depending upon size requirements and availability.

The positioning of C12 is very important - this should be as close to the WM8912 as possible.

It is important to select a suitable capacitor type for the Charge Pump. Note that the capacitance may vary with DC voltage; care is required to ensure that required capacitance is achieved at the applicable operating voltage, as specified in Table 66. The capacitor datasheet should be consulted for this information.

COMPONENT	REQUIRED CAPACITANCE	VALUE	PART NUMBER	VOLTAGE	TYPE	SIZE
C12 (CPCA-CPCB)	$\geq 1\mu\text{F}$ at 2VDC	2.2 μF	Kemet C0402C225M9PAC	6.3v	X5R	0402
C17 (CPVOUTP)	$\geq 2\mu\text{F}$ at 2VDC	2.2 μF	MuRata GRM188R61A225KE34D	10v	X5R	0603
C18 (CPVOUTN)		4.7 μF	MuRata GRM155R60J475M_EIA	6.3v	X5R	0402

Table 66 Charge Pump Capacitors

3. ZOBEL NETWORKS

The Zobel network shown in Figure 56 is required on HPOUTL, HPOUTR, LINEOUTL and LINEOUTR whenever that output is enabled. Stability of these ground-referenced outputs across all process corners cannot be guaranteed without the Zobel network components. (Note that, if any ground-referenced output pin is not required, the zobel network components can be omitted from the output pin, and the pin can be left floating.) The Zobel network requirement is detailed further in the applications note WAN_0212 "Class W Headphone Impedance Compensation".

Zobel networks (C9, C10, C11, C16, R3, R4, R5, R6) should be positioned reasonably close to the WM8912.

PACKAGE DIMENSIONS

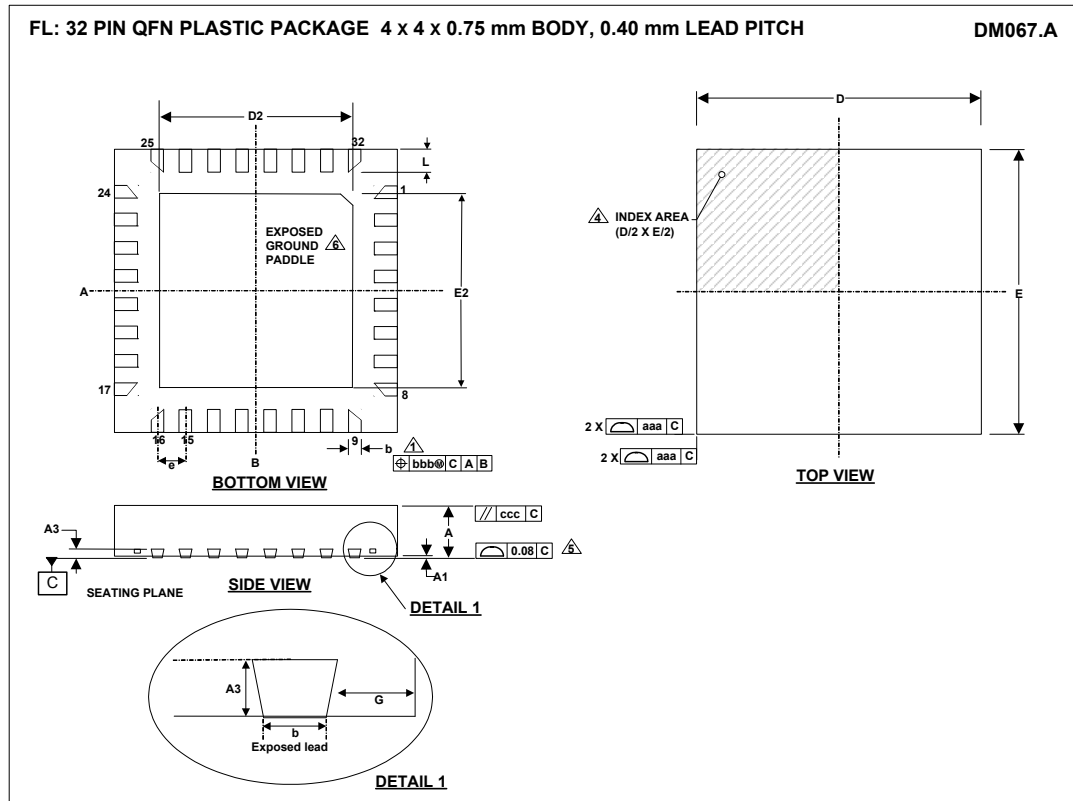

Symbols	Dimensions (mm)			NOTE
	MIN	NOM	MAX	
A	0.70	0.75	0.8	
A1	0	0.035	0.05	
A3		0.203 REF		
b	0.15	0.2	0.25	1
D		4.00 BSC		
D2	2.65	2.7	2.75	2
E		4.00 BSC		
E2	2.65	2.7	2.75	2
e		0.40 BSC		
G		0.5		
L	0.35	0.40	0.45	
Tolerances of Form and Position				
aaa		0.05		
bbb		0.10		
ccc		0.10		
REF:				

- NOTES:
1. DIMENSION b APPLIES TO METALLIZED TERMINAL AND IS MEASURED BETWEEN 0.15 mm AND 0.25 mm FROM TERMINAL TIP.
 2. ALL DIMENSIONS ARE IN MILLIMETRES.
 3. THE TERMINAL #1 IDENTIFIER AND TERMINAL NUMBERING CONVENTION SHALL CONFORM TO JEDEC 95-1 SPP-002.
 4. COPLANARITY APPLIES TO THE EXPOSED HEAT SINK SLUG AS WELL AS THE TERMINALS.
 5. REFER TO APPLICATION NOTE WAN_0118 FOR FURTHER INFORMATION REGARDING PCB FOOTPRINTS AND QFN PACKAGE SOLDERING.
 6. THIS DRAWING IS SUBJECT TO CHANGE WITHOUT NOTICE.

IMPORTANT NOTICE

Wolfson Microelectronics plc ("Wolfson") products and services are sold subject to Wolfson's terms and conditions of sale, delivery and payment supplied at the time of order acknowledgement.

Wolfson warrants performance of its products to the specifications in effect at the date of shipment. Wolfson reserves the right to make changes to its products and specifications or to discontinue any product or service without notice. Customers should therefore obtain the latest version of relevant information from Wolfson to verify that the information is current.

Testing and other quality control techniques are utilised to the extent Wolfson deems necessary to support its warranty. Specific testing of all parameters of each device is not necessarily performed unless required by law or regulation.

In order to minimise risks associated with customer applications, the customer must use adequate design and operating safeguards to minimise inherent or procedural hazards. Wolfson is not liable for applications assistance or customer product design. The customer is solely responsible for its selection and use of Wolfson products. Wolfson is not liable for such selection or use nor for use of any circuitry other than circuitry entirely embodied in a Wolfson product.

Wolfson's products are not intended for use in life support systems, appliances, nuclear systems or systems where malfunction can reasonably be expected to result in personal injury, death or severe property or environmental damage. Any use of products by the customer for such purposes is at the customer's own risk.

Wolfson does not grant any licence (express or implied) under any patent right, copyright, mask work right or other intellectual property right of Wolfson covering or relating to any combination, machine, or process in which its products or services might be or are used. Any provision or publication of any third party's products or services does not constitute Wolfson's approval, licence, warranty or endorsement thereof. Any third party trade marks contained in this document belong to the respective third party owner.

Reproduction of information from Wolfson datasheets is permissible only if reproduction is without alteration and is accompanied by all associated copyright, proprietary and other notices (including this notice) and conditions. Wolfson is not liable for any unauthorised alteration of such information or for any reliance placed thereon.

Any representations made, warranties given, and/or liabilities accepted by any person which differ from those contained in this datasheet or in Wolfson's standard terms and conditions of sale, delivery and payment are made, given and/or accepted at that person's own risk. Wolfson is not liable for any such representations, warranties or liabilities or for any reliance placed thereon by any person.

ADDRESS

Wolfson Microelectronics plc

Westfield House

26 Westfield Road

Edinburgh

EH11 2QB

Tel :: +44 (0)131 272 7000

Fax :: +44 (0)131 272 7001

Email :: sales@wolfsonmicro.com

REVISION HISTORY

DATE	REV	DESCRIPTION OF CHANGES	CHANGED BY
31/01/13	4.1	Order codes changed from WM8912GEFL/V and WM8912GEFL/RV to WM8912CGEFL/V and WM8912CGEFL/RV to reflect change to copper wire bonding.	JMacD