



F6482 Series Product Brief

PB024602-1113

ADVANTAGES

- AES Encryption Engine simplifies secure data communications while reducing CPU overhead
- DMA offloads the CPU from real-time tasks
- Flexible clocking scheme allows peripherals to operate while the CPU is in Stop Mode

F6482 Series General-Purpose Flash Microcontroller

Overview

Zilog's F6482 Series MCUs, members of the Z8 Encore! XP® family, are based on Zilog's advanced 8-bit eZ8 CPU core. These microcontrollers are optimized for low-power, sensing, and wireless applications, and support 1.8 V to 3.6 V low-voltage operation with extremely low Active, Halt, and Stop Mode currents, plus they offer an assortment of speed and low-power options. In addition, the feature-rich analog and digital peripherals and serial I/O of the F6482 Series makes them suitable for a variety of applications, including safety and security, utility metering, digital power supervisory, hand-held electronic devices, and general motor control.

The F6482 Series features 26 to 67 port pins (Ports A–J) for general-purpose input/output (GPIO). The number of GPIO pins available is a function of package. Each pin is individually programmable.

Features

- 24MHz eZ8 CPU core
- 16KB, 32KB, 60KB or 64KB Flash memory with in-circuit programming capability
- 2KB or 3.75KB internal RAM
- Up to 128 bytes Non-Volatile Data Storage (NVDS)
- 12-bit (or 14-bit 2-pass) Analog-to-Digital Converter
 - Up to 12 external channels plus dedicated inputs for Op Amps (2)
 - Temperature Sensor, AVDD/2, and Bandgap
 - Internal or external voltage reference and single-ended or differential inputs
- 12-bit Digital-to-Analog Converter (DAC)
- Integrated LCD driver with blinking and contrast control for up to 96 segments (4 common by 24 segment lines)
- 128-bit Advanced Encryption Standard (AES) encryption/decryption hardware accelerator according to FIPS PUB 197
- Real-Time Clock (RTC) supporting both Counter and Clock modes
- On-Chip Temperature Sensor
- Two on-chip low power analog comparators
- Two on-chip, low-power operational amplifiers
- 8-Channel Event System provides communication between peripherals for autonomous triggering
- Full-Speed Universal Serial Bus (USB 2.0) device supporting eight endpoints with integrated USB-PHY
- Two full-duplex UARTs with Local Interconnect Network (LIN), Digital Addressable Lighting Interface (DALI) and Digital Multiplex (DMX) protocol modes. Support for 9-bit (Multi-Processor) and RS-485 (Driver Enable)
- Two Enhanced Serial Peripheral Interface (SPI) controllers
- I²C controller which supports Master/Slave modes
- Four-channel DMA controller with direct or linked-list operation
- Three enhanced 16-bit timers with Capture, Compare, and PWM capability
- Two additional basic 16-bit timers with interrupt (shared as UART Baud Rate Generator)
- 16-bit Multi-Channel Timer which supports four Capture/Compare/PWM modules

APPLICATIONS

- Safety and Security
- Utility Metering
- Digital Power Supervisory
- Hand-Held Electronics
- Motor Control
- Wireless Controller
- LCD Keypads

Features (continued)

- Watchdog Timer (WDT)
- 26 to 67 General-Purpose Input/Output (GPIO) pins, depending upon package
- Up to 41 interrupt sources with up to 30 interrupt vectors
- On-Chip Debugger (OCD)
- Power-On Reset (POR) and Voltage Brown-Out (VBO) protection
- Built-in Low-Voltage Detection (LVD) with programmable voltage threshold
- Low Frequency Crystal Oscillator (LFXO) operating at 32.768 kHz with low power consumption
- Internal clock sources and clock multiplication including: Internal Precision Oscillator (IPO), Digitally Controlled Oscillator (DCO), Watchdog Timer Oscillator (WTO), Frequency Locked Loop (FLL) and Phase Locked Loop (PLL)
- High-Frequency Crystal Oscillator (HFXO) operating in the 1-24 MHz range
- Wide operation voltage range: 1.8 V-3.6 V
- 32-, 44-, 64-, and 80-pin packages
- -40°C to +85°C (extended) operating temperature range

Block Diagram

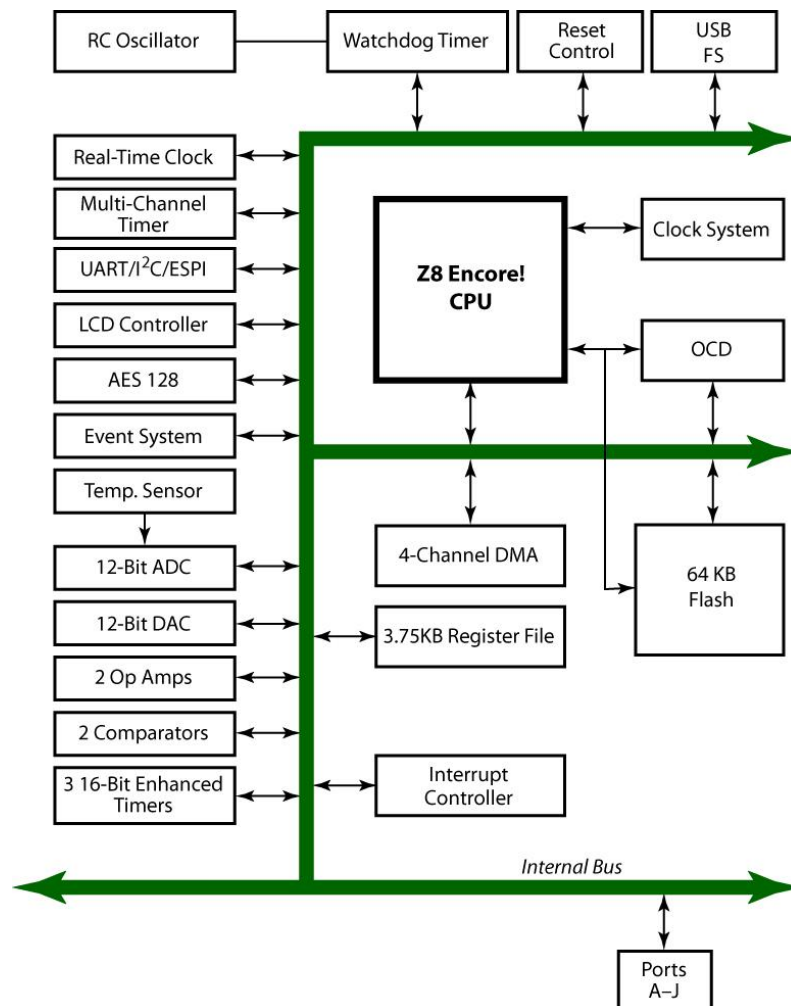

F6482 Series Block Diagram

Pin Signals

ADVANTAGES

- Event System allows autonomous peripheral interoperation
- Low-power op amps and comparators are ideal for PIR motion detection
- ADC features programmable automatic conversion averaging, removing this task from the CPU

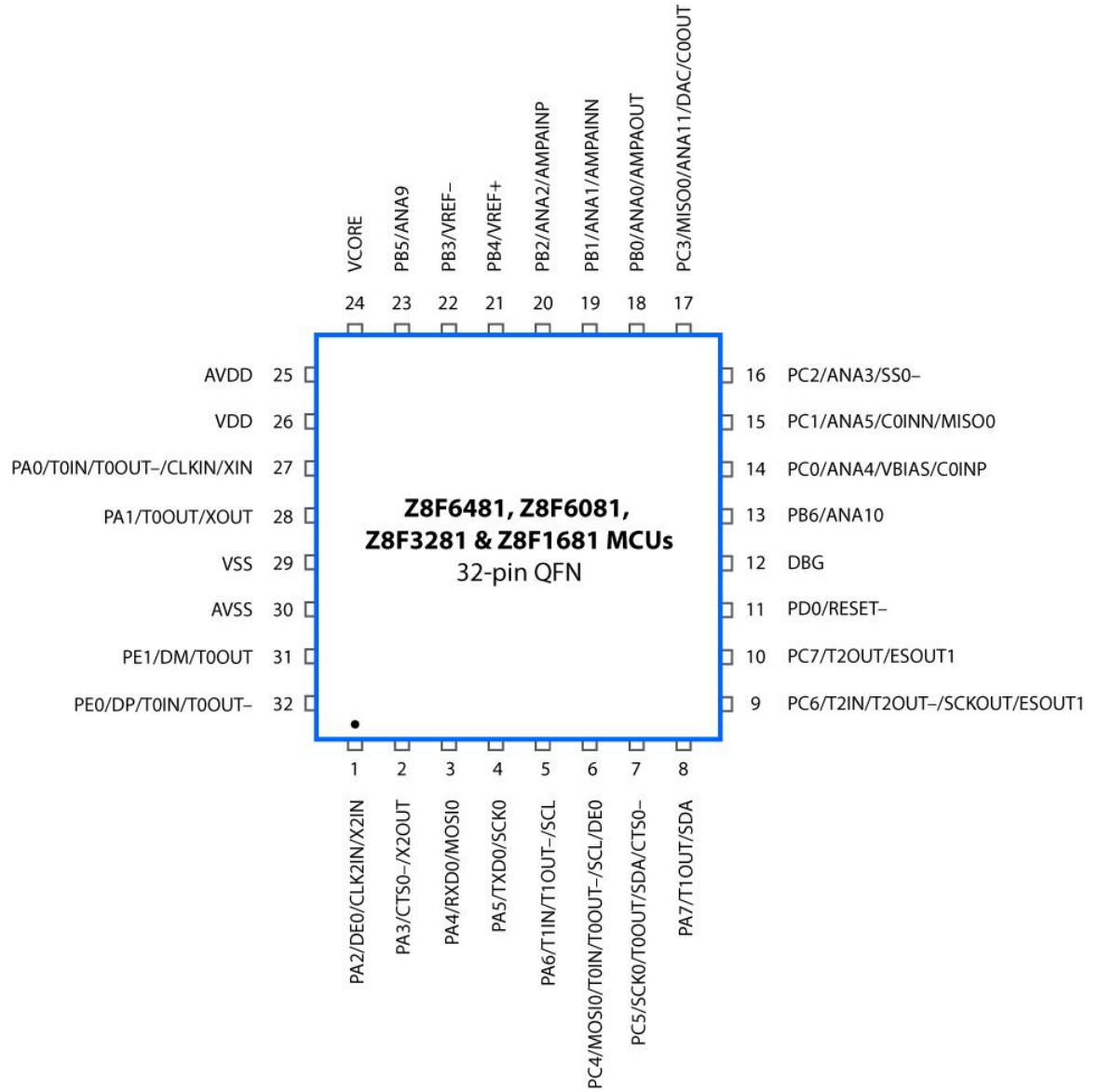

Z8Fxx81 MCUs: 32-Pin QFN Configuration

Pin Signals

APPLICATIONS

- Passive Infrared Motion Detection
- Intelligent Lighting Controllers
- DMX Bus Products
- UPS Systems
- LED Lighting Control
- Thermostats
- Learning Universal Remote Controllers

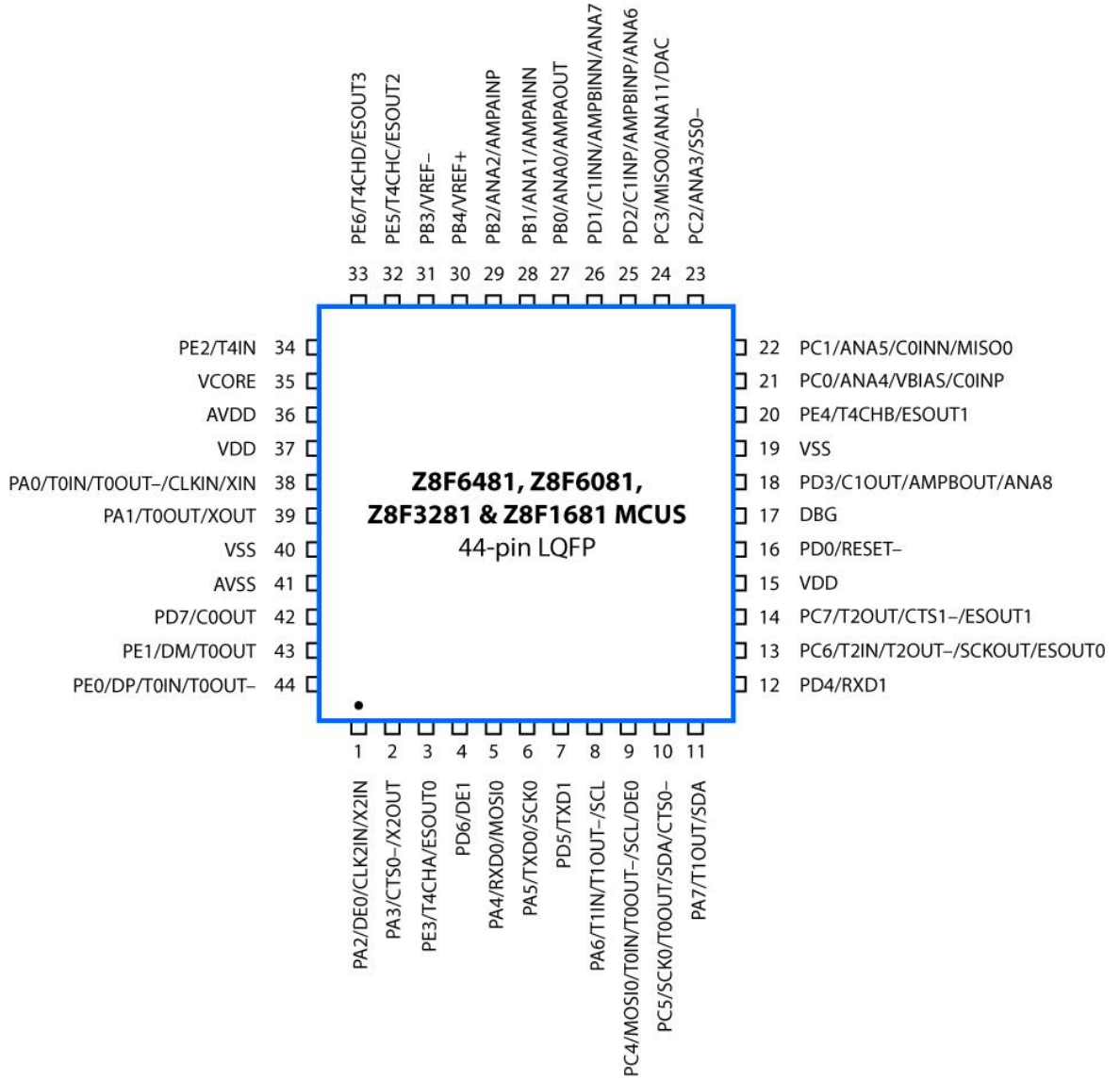

Z8Fxx81 MCUs: 44-Pin LQFP Configuration

Pin Signals

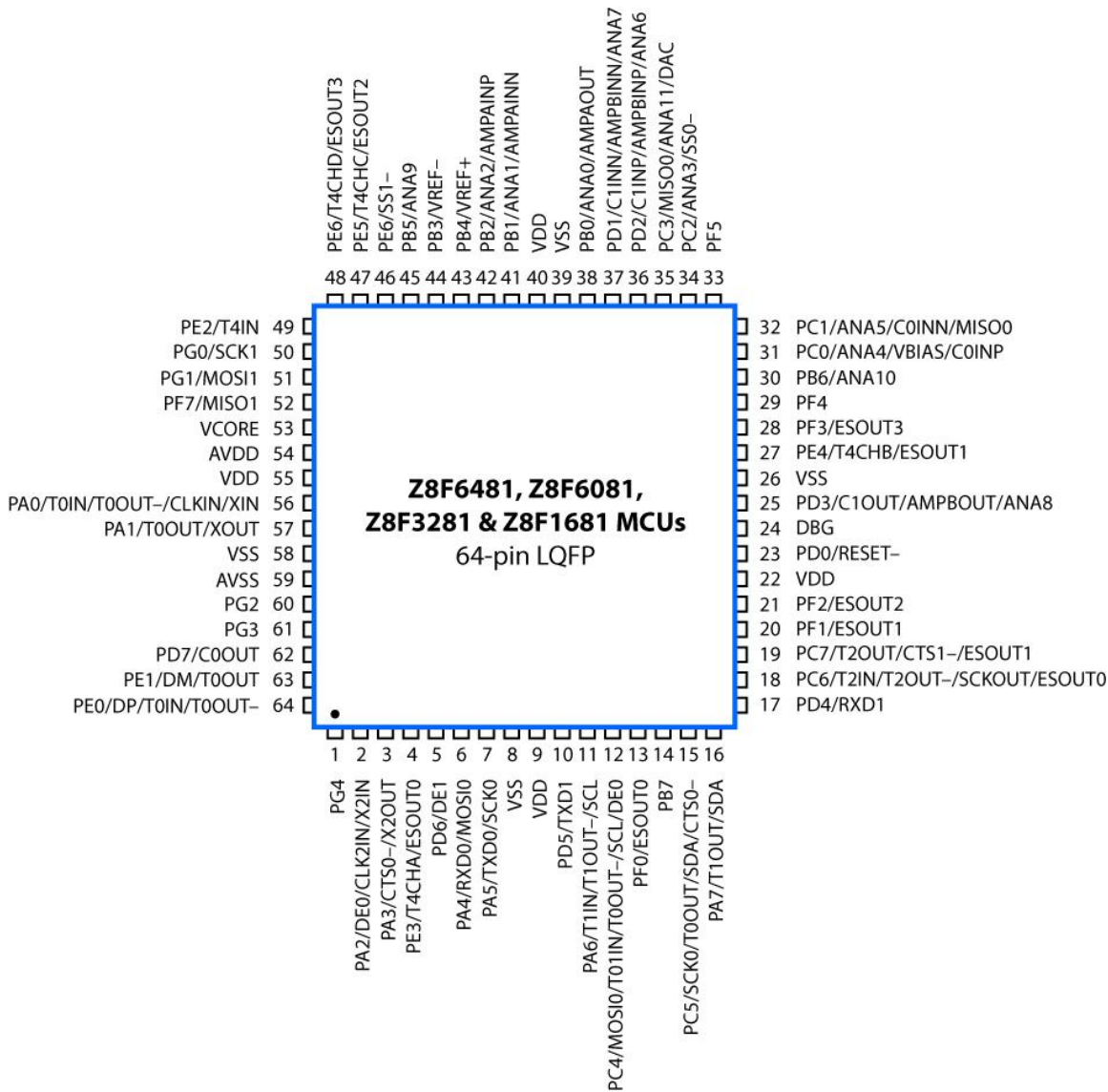

Z8Fxx81 MCUs: 64-Pin LQFP Configuration

Pin Signals

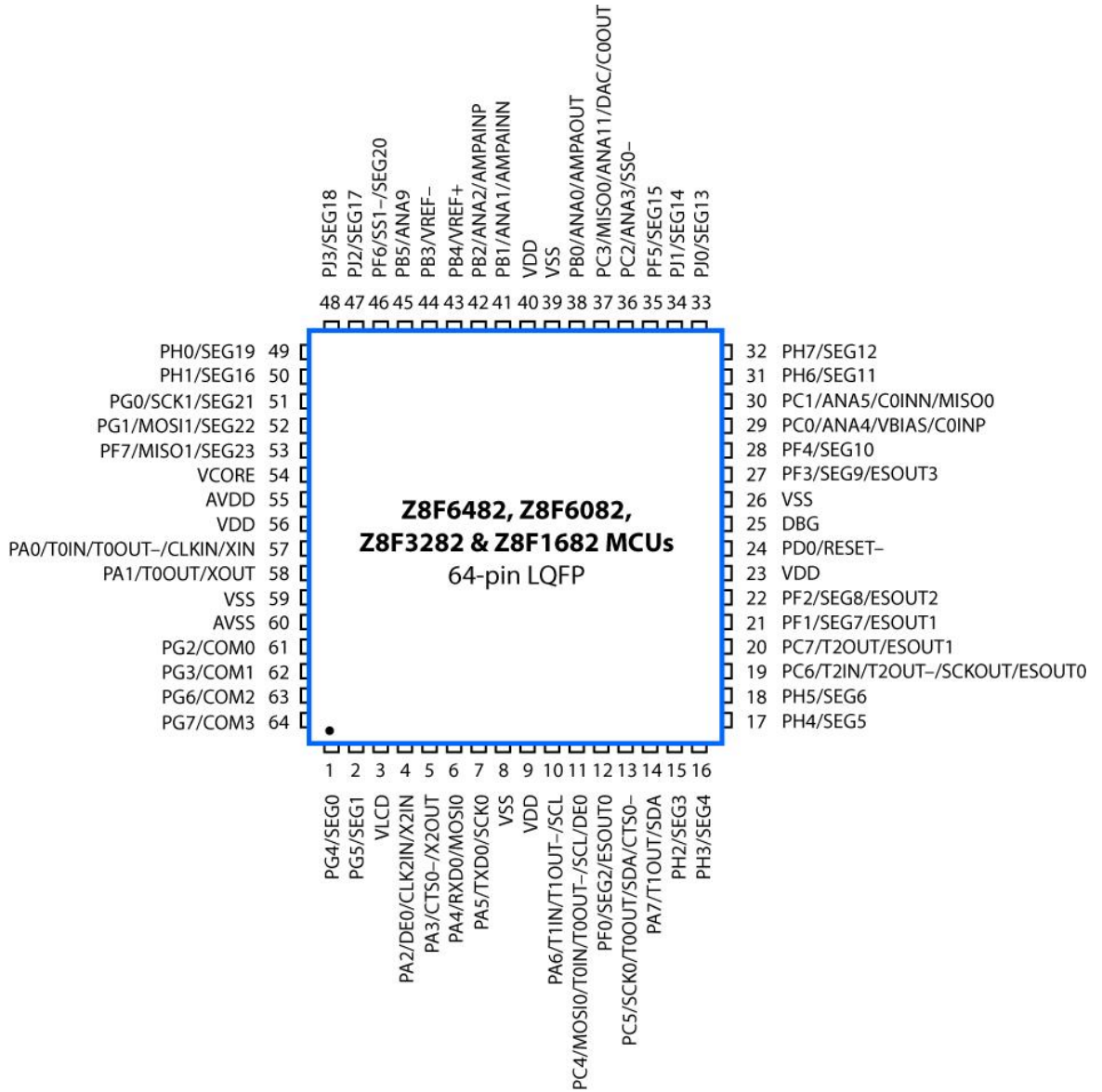

Z8Fxx82 MCUs: 64-Pin LQFP Configuration

Pin Signals

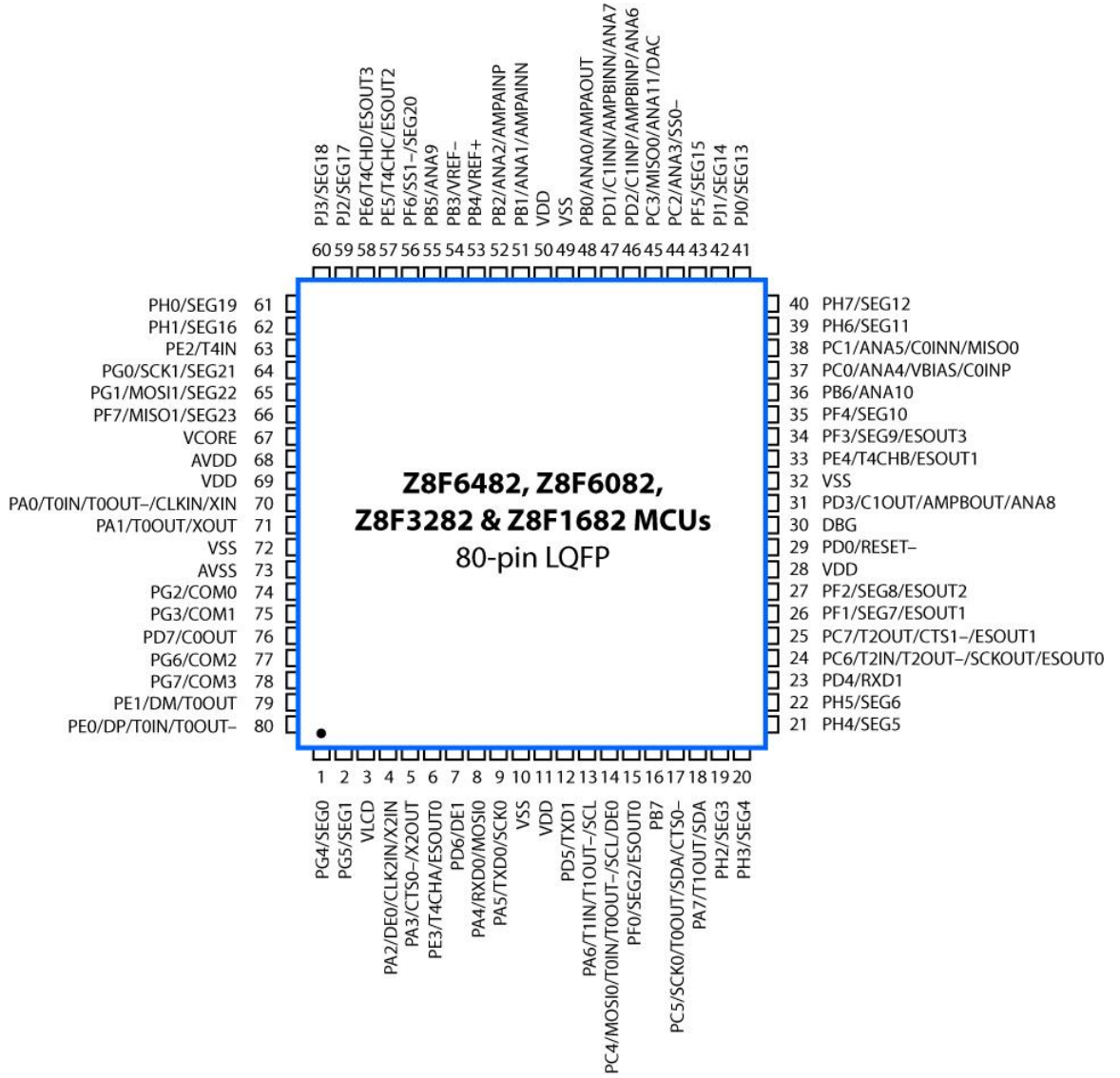

Z8Fxx82 MCUs: 80-Pin LQFP Configuration

Operating Characteristics

- Operating Voltage Range: 1.8V to 3.6V up to 24 MHz
- Operating Temperature Range: -40°C to 85°C

Development Tools

The F6482 Series is backed by a comprehensive development tools package that includes all of the necessary design essentials to get your application up and running in record time. This package, the F6482 Development Kit, contains the following tools:

- F6482 Series Development Board
- USB SmartCable for connecting the PC to the F6482 Series Development Board
- USB A to Mini B cable
- RS-232 interface module
- Development Kit Insert (FL0160)

The F6482 Series is also supported by ZDS II – Zilog’s Integrated Development Environment (IDE) with an ANSI C-Compiler. Download the latest version of ZDS II for Z8 Encore! XP devices free from the [Zilog Store](#).

Hardware Tools & Part Number Ordering Information

- F6482 Series Development Kit, complete with USB SmartCable (part number Z8F64820100ZCOG)
- USB SmartCable Accessory Kit, available separately (part number ZUSBSC00100ZACG)
- Opto-Isolated USB SmartCable Accessory Kit (part number ZUSBOPTSC01ZACG, the opto-isolated version of ZUSBSC0100ZACG)

Software Tools & Support

- Zilog Developer Studio Integrated Development Environment (ZDS II IDE) includes a full ANSI C Compiler, Assembler, Linker, Debugger, Simulator, and Editor.

Ordering Information

Order your F6482 Series products from your local Zilog distributor using the part numbers listed below. For more information, or to download product collateral and software, please visit us at www.zilog.com.

Part	Flash	Register RAM	128B NVDS	LCD	USB	I ² C ¹	ESPI	UART ²	I/O	ADC ³	Package	PSI
Z8F6482	64 KB	3.75 KB	0	1	1	1	2	2	67	12	80-Pin LQFP	Z8F6482AT024XK
		3.75 KB	0	1	0	1	2	1	51	8	64-Pin LQFP	Z8F6482AR024XK
Z8F6481	64 KB	3.75 KB	0	0	1	1	2	2	52	12	64-Pin LQFP	Z8F6481AR024XK
		3.75 KB	0	0	1	1	1	2	36	10	44-Pin LQFP	Z8F6481AN024XK
		3.75 KB	0	0	1	1	1	1	26	9	32-Pin QFN	Z8F6481QK024XK
Z8F6082	60 KB	3.75 KB	1	1	1	1	2	2	67	12	80-Pin LQFP	Z8F6082AT024XK
		3.75 KB	1	1	0	1	2	1	51	8	64-Pin LQFP	Z8F6082AR024XK
Z8F6081	60 KB	3.75 KB	1	0	1	1	2	2	52	12	64-Pin LQFP	Z8F6081AR024XK
		3.75 KB	1	0	1	1	1	2	36	10	44-Pin LQFP	Z8F6081AN024XK
		3.75 KB	1	0	1	1	1	1	26	9	32-Pin QFN	Z8F6081QK024XK
Z8F3282	32 KB	3.75 KB	1	1	1	1	2	2	67	12	80-Pin LQFP	Z8F3282AT024XK
		3.75 KB	1	1	0	1	2	1	51	8	64-Pin LQFP	Z8F3282AR024XK
Z8F3281	32 KB	3.75 KB	1	0	1	1	2	2	52	12	64-Pin LQFP	Z8F3281AR024XK
		3.75 KB	1	0	1	1	1	2	36	10	44-Pin LQFP	Z8F3281AN024XK
		3.75 KB	1	0	1	1	1	1	26	9	32-Pin QFN	Z8F3281QK024XK
Z8F1682	16 KB	2 KB	1	1	1	1	2	2	67	12	80-Pin LQFP	Z8F1682AT024XK
		2 KB	1	1	0	1	2	1	51	8	64-Pin LQFP	Z8F1682AR024XK
Z8F1681	16 KB	2 KB	1	0	1	1	2	2	52	12	64-Pin LQFP	Z8F1681AR024XK
		2 KB	1	0	1	1	1	2	36	10	44-Pin LQFP	Z8F1681AN024XK
		2 KB	1	0	1	1	1	1	26	9	32-Pin QFN	Z8F1681QK024XK

Notes:

1. I²C Master/Slave Controller.
2. UART with LIN/DALI/DMX.
3. 12-Bit Analog/Digital Channels.

Warning: DO NOT USE THIS PRODUCT IN LIFE SUPPORT SYSTEMS.**LIFE SUPPORT POLICY**

ZILOG'S PRODUCTS ARE NOT AUTHORIZED FOR USE AS CRITICAL COMPONENTS IN LIFE SUPPORT DEVICES OR SYSTEMS WITHOUT THE EXPRESS PRIOR WRITTEN APPROVAL OF THE PRESIDENT AND GENERAL COUNSEL OF ZILOG CORPORATION.

As used herein

Life support devices or systems are devices which (a) are intended for surgical implant into the body, or (b) support or sustain life and whose failure to perform when properly used in accordance with instructions for use provided in the labeling can be reasonably expected to result in a significant injury to the user. A critical component is any component in a life support device or system whose failure to perform can be reasonably expected to cause the failure of the life support device or system or to affect its safety or effectiveness.

Document Disclaimer

©2013 Zilog, Inc. All rights reserved. Information in this publication concerning the devices, applications, or technology described is intended to suggest possible uses and may be superseded. ZILOG, INC. DOES NOT ASSUME LIABILITY FOR OR PROVIDE A REPRESENTATION OF ACCURACY OF THE INFORMATION, DEVICES, OR TECHNOLOGY DESCRIBED IN THIS DOCUMENT. ZILOG ALSO DOES NOT ASSUME LIABILITY FOR INTELLECTUAL PROPERTY INFRINGEMENT RELATED IN ANY MANNER TO USE OF INFORMATION, DEVICES, OR TECHNOLOGY DESCRIBED HEREIN OR OTHERWISE. The information contained within this document has been verified according to the general principles of electrical and mechanical engineering.

Z8 is a trademark or registered trademark of Zilog, Inc. All other product or service names are the property of their respective owners.

zilog[®]

Embedded in Life

An  IXYS Company

WWW.ZILOG.COM | 408-457-9000

Zilog and the Zilog logo are registered trademarks of Zilog, Inc. in the United States and in other countries.

