

eZ80F91 MCU

Product Brief

PB013507-0412

Product Block Diagram

eZ80F91 MCU			
256 KB Flash+ 512 B Flash		32-Bit GPIO	
8 KB SRAM		10/100 Mbps Ethernet MAC 8KB Frame Buffer	
Infrared Encoder/ Decoder	2 UART	I ² C	SPI
4 PRT	WDT	Real Time Clock	
4 CS +WSG	JTAG	ZDI	PLL

Key Features

The eZ80F91 MCU is a member of Zilog's eZ80Acclaim! product family, which offers on-chip Flash versions of Zilog's eZ80® processor core. The eZ80F91 MCU offers the following features:

- 50MHz high-performance eZ80 CPU
- 256KB Flash Program Memory and extra 512 B device configuration Flash Memory
- 32 bits of General-Purpose Input/Output (GPIO)
- 16KB total on-chip high-speed SRAM:
 - 8KB for general-purpose use
 - 8KB for 10/100BaseT Ethernet Media Access Controller (EMAC) high-speed frame buffer
- IrDA-compatible infrared encoder/decoder
- Two universal asynchronous receiver/transmitter (UARTs) with independent baud rate generators

- Inter-integrated circuit (I²C) and serial peripheral interface (SPI) with independent clock rate generator
- Four counter/timers with prescalers supporting event counting, input capture, output compare, and Pulse Width Modulator (PWM) modes
- Watchdog Timer (WDT) with internal RC clocking option
- Real time clock (RTC) with on-chip 32KHz oscillator, selectable 50/60Hz input, and separate RTC_V_{DD} pin for battery backup
- Glueless external memory interface with 4 Chip-Selects/Wait-State Generators and external $\overline{\text{WAIT}}$ input pin. It also supports Intel and Motorola buses
- JTAG and Zilog Debug Interface (ZDI) supporting emulation features
- Low-power PLL and on-chip oscillator
- Programmable-priority vectored interrupts, non-maskable interrupts, and interrupt controller
- New DMA-like eZ80 CPU instructions
- Power management features supporting HALT/SLEEP modes and selective peripheral power-down controls
- 144-pin BGA package or 144-pin LQFP package
- 3.0V to 3.6V supply voltage with 5 V-tolerant inputs
- Operating temperature ranges:
 - Standard, 0°C to +70°C
 - Extended, -40°C to +105°C

General Description

The eZ80F91 MCU is industry's first MCU featuring a high-performance 8-bit microcontroller with an integrated 10/100BaseT EMAC. It is a power-efficient, optimized pipeline architecture

microcontroller with a maximum operating speed of 50 MHz. Offering on-chip Flash Memory, SRAM, Ethernet MAC, and rich peripherals, the eZ80F91 is well-suited for industrial, communication, automation, security, and embedded Internet applications.

eZ80 CPU Core

The eZ80 CPU operates either in Z80-compatible (64 KB) mode or full 24-bit (16 MB) addressing mode. Considering both the increased clock speed and processor efficiency, the processing power of the eZ80 CPU competes with the performance of 16-bit microprocessors. The eZ80 improves on the world-famous Z80 architecture. Like the Z80, the eZ80 CPU features dual bank registers for fast context switching.

eZ80F91 MCU Peripherals Description

The eZ80F91 MCU includes the following peripheral elements:

On-Chip Memory

The eZ80F91 device offers 256KB of Flash Program Memory. A separate page of 512 bytes Flash memory is available for general device configuration data. Other on-chip memory features include:

- Single power supply operation
- Page erase feature: 2048 bytes/page
- Fast page erase and byte program operation
- 78ns minimum read cycle
- Endurance: 10,000 write cycles (typical)
- Data can be retained for more than 100 years at room temperature

In addition, 16KB of high-speed, relocatable SRAM is available, of which 8KB is for general-purpose use. Another 8KB of SRAM is used by the EMAC for Ethernet operation, but is also user-accessible when Ethernet functionality is not required.

General-Purpose Input/Output

There are 32 bits of GPIO. All GPIO pins are individually programmable and support the

following I/O modes: input, output, open drain, open source, level-triggered interrupts (High or Low), edge-triggered interrupts (High or Low), dual edge-triggered interrupts, and alternate function. Eight of the output pins can drive 10mA each (Port A), while 16 other pins feature Schmitt-trigger input buffers (Port B and Port C).

10/100BaseT Ethernet MAC

The eZ80F91 MCU features an integrated IEEE 802.3 Ethernet controller with 8 KB of dynamically-configurable Tx/Rx frame buffer. It supports speed of 10 Mbps and 100Mbps, full duplex operation, and an industry-standard Media Independent Interface (MII) for simple connection to an external Physical Layer interface (PHY) device. The eZ80F91 MCU delivers high performance and overall cost effectiveness as an embedded network microcontroller.

High performance is achieved by optimizing the internal bus design of the eZ80 CPU with shared memories, dedicated Ethernet Tx/Rx DMAs, and Tx/Rx FIFOs. This bus design provides the highest data throughput over the Ethernet interface, yet requires minimum eZ80 CPU intervention and minimizes system loading.

Infrared Encoder/Decoder

- Supports IrDA SIR format
- Operates seamlessly with on-chip UART
- Interfaces with IrDA-compliant transceivers
- Supports transmit/receive to 115Kbps

Universal Asynchronous Receiver/Transmitter

Each of the two UART channels contains a transmitter, a receiver, control logic/registers, and a Baud Rate Generator (BRG).

- The BRG produces a lower-frequency bit clock from the system clock. All standard baud rates up to 115Kbps (and higher) are supported.
- The UART module implements the logic required to support asynchronous communications, hardware flow control, and 9-bit character format. The module also contains separate 16-byte-deep transmit and receive FIFOs.

Inter-Integrated Circuit

The I²C channel contains control registers and a clock rate generator. The I²C interface operates in four modes: Master Transmit or Receive and Slave Transmit or Receive. A standard and fast I²C speed of 100kbps and 400kbps are supported.

Serial Peripheral Interface

The SPI channel contains control registers and a clock rate generator. The SPI is a synchronous serial interface allowing multiple SPI devices to be interconnected. The SPI interface is configured to function either as a master or a slave.

Programmable Reload Timers

The eZ80F91 MCU provides four independent Programmable Reloadable Counter Timers (PRT) to handle complex timing functions. Each timer is a 16-bit downcounter and offers a 4-bit clock prescaler with four selectable taps for $CLK \div 4$, $CLK \div 16$, $CLK \div 64$ and $CLK \div 256$. The timers operate in basic mode supporting SINGLE-PASS or CONTINUOUS count. Additional features include 4 input captures, 4 output compares, 2 external event counters, and 4 PWMs that can operate independently or in unison. Any one of the input capture pins can be programmed as master PWM power-trip inputs.

Watchdog Timer

The WDT features four programmable time-out periods. It operates either from the main system clock, the on-chip 32 KHz oscillator (from the RTC), or the internal RC oscillator. The time-out action of the WDT is user-programmable for either a hardware reset or a non-maskable interrupt to the eZ80 CPU. The source of action taken after a WDT time-out is indicated by a WDT status bit.

Real Time Clock

The RTC allows counting of seconds, minutes, hours, day-of-the-week, day-of-the-month, month, year, and century. Alarms and interrupts can be set for seconds, minutes, hours, and day-of-the-week. The RTC input is taken either from the on-chip 32 KHz oscillator or from a 50/60 Hz input. The

RTC operates from an isolated RTC_V_{DD} pin to allow constant operation from a battery.

Chip-Select/Wait State Generator and WAIT Pin

Four independent chip selects facilitate glueless interface to system memory and external devices. Each chip-select can be configured for up to 7 wait states and supports either memory or I/O space. Memory chip selects can be individually programmed on a 64KB boundary. I/O chip selects can choose a 256-byte section of I/O space. The WAIT input pin allows interface with slow peripherals. It also supports Z80, Intel, and Motorola bus modes.

JTAG Interface

An IEEE 1149.1-compatible five-pin test access port (TAP) is provided to interface with on-chip test logic defined by IEEE standard. The TAP also includes Boundary Scan functions and is used to control on-chip emulation/debugging capabilities. Some features include software break points, 64-word trace buffer, complex break points using address and data masks, and cascadable triggers.

PLL and On-Chip Crystal Oscillator

The eZ80F91 MCU features a low-power, programmable PLL that can be selected to generate the system clock. Taking the input from the on-chip crystal oscillator, the PLL generates system clock speed up to 50 MHz from low-cost, low-frequency external crystals in the range of 1 MHz to 10MHz.

Zilog Debug Interface

The Zilog Debug Interface (ZDI) incorporates the functions of an in-circuit emulator. ZDI allows you to single-step code, change registers, edit programs, and view status of the internal registers.

Block Transfer Instructions

Block transfer instructions with expanded repeat capability are added to the eZ80 CPU. They provide high-performance data transfer similar to hardware DMAs.

Power Management

The eZ80F91 MCU supports several power management features. Two peripheral Power-Down Registers allow independent clock gating of on-chip peripherals under software control while operating under normal conditions. The eZ80 CPU writes to the control registers to disable the clock from driving any one of the peripherals while they are inactive.

In addition, execution of the HALT instruction suspends eZ80 CPU operation and eliminates clock power associated with the eZ80 CPU core. Normal operation is restored via external and peripheral interrupts or hardware reset.

Execution of a sleep (SLP) instruction provides the lowest power consumption. In SLEEP mode, only the on-chip RTC 32KHz crystal oscillator remains active to drive the RTC and the WDT. Other peripherals like the system clock, and the primary oscillator are disabled. You can reset the device by RTC alarm, a WDT time-out, or hardware reset.

Electrical Features Summary

- Power supply, 3.3V \pm 0.3V
- Standard temperature, 0°C to 70°C

- Extended temperature, -40°C to +105°C
- Supply current at 50MHz; 50mA (typical)
- Supply current in HALT mode with peripherals powered down; <5 mA (typical)
- Supply current, SLEEP mode: <50 μ A (typical)

Support Tools

The following development tools are available to program and debug the eZ80F91 MCU:

Hardware

- eZ80Acclaim*Plus!* Development Kit

Software

- Zilog TCP/IP (ZTP) software suite
- ANSI C-Compiler
- Zilog Developer Studio Integrated Development Environment (ZDS II IDE) including assembler, linker, debugger, and simulator

Related Products

Additional integrated devices of interest are presented in Table 1.

Table 1. Related Products

eZ80190	50 MHz eZ80 CPU, 8 KB SRAM, 16x16 multiply with 40-bit accumulators, 32 bits GPIO, 6 Counter Timers with prescalers, WDT, 4 channel CS+WSG, 2 Channel DMA, 2 UZI Channels, ZDI, On-Chip Oscillator.
eZ80L92	20 MHz and 50 MHz eZ80 CPU, low-power modes, 24 bits GPIO, IrDA, 2 UART, I ² C, SPI, 6 Counter Timers with I/O features, WDT, RTC, 4 channel CS, JTAG, ZDI.
eZ80F92	20 MHz eZ80 CPU, low-power modes, 128 KB+256 B Flash, 8 KB SRAM, 24 bits GPIO, IrDA, 2 UART, I ² C, SPI, 6 Counter Timers with I/O features, WDT, RTC, 4 channel CS+WSG, JTAG, ZDI, PLL.
eZ80F93	20 MHz eZ80 CPU, low-power modes, 64KB+256B Flash, 4 KB SRAM, 24 bits GPIO, IrDA, 2 UART, I ² C, SPI, 6 Counter Timers with I/O features, WDT, RTC, 4 channel CS+WSG, JTAG, ZDI.
Z80S180	Improved Z80 CPU, 1 MB MMU, 2 DMA, 2 16-bit PRTs, 2 UARTs, CSIO, up to 33MHz clock speed.
Z80181	Z8S180 CPU, SCC, CTC, 16-bit GPIO, up to 33MHz clock speed.
Z80182	Z8S180 CPU, 2 ESCC, 24-bit GPIO, 16550 Mimic interface, up to 33MHz clock speed.
Z84C00	Z80 CPU (up to 20MHz).
Z84C15	Z80 CPU, 2 SIO, 4x8 CTC, 2 PIO, WDT, up to 16MHz clock speed.

Block Diagram

Figure 1 shows a block diagram of the eZ80F91 MCU.

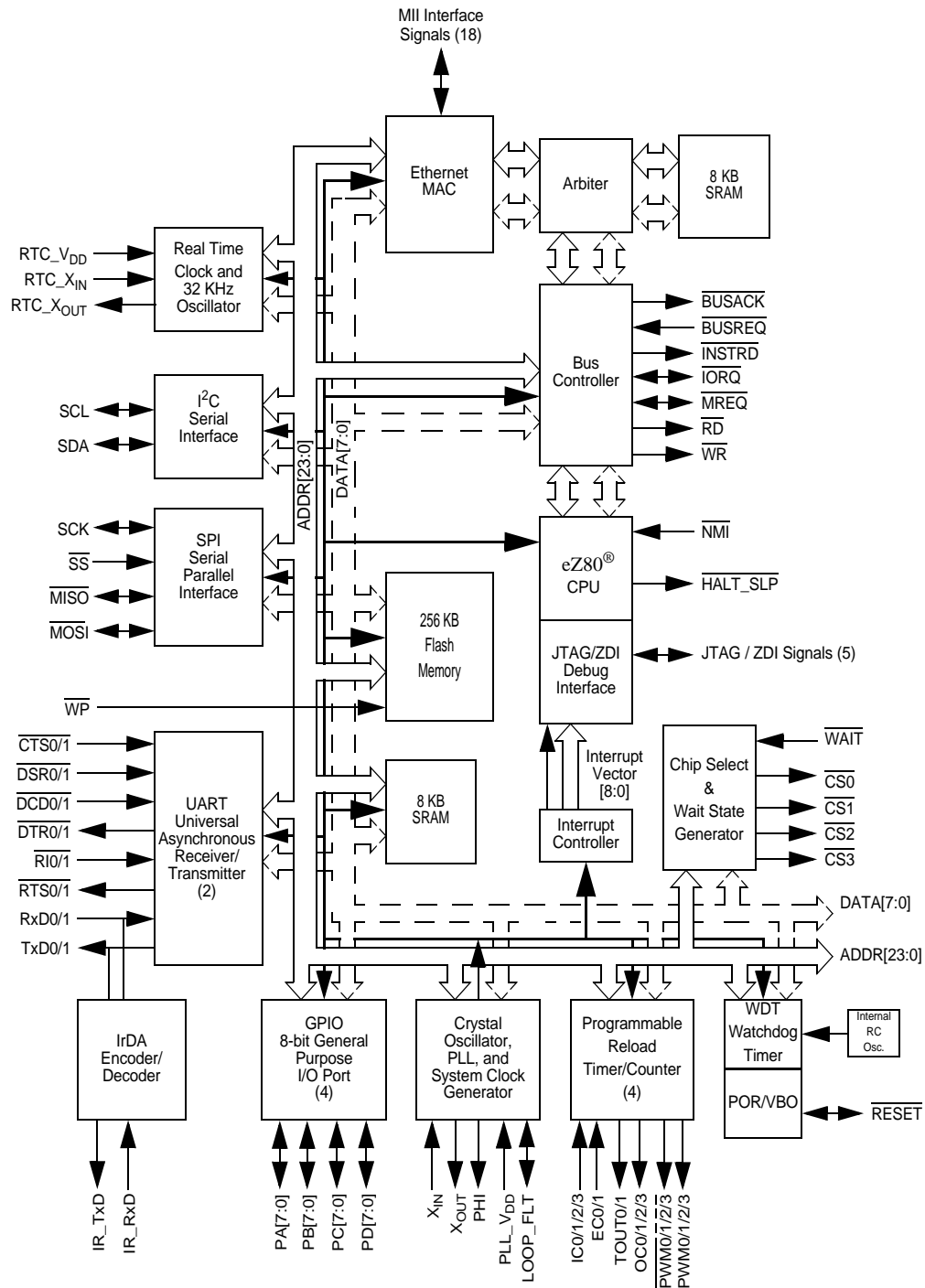

Figure 1. eZ80F91 Block Diagram

Pin Diagrams

Figure 2 illustrates the 144-pin LQFP pin configuration of eZ80F91 MCU.

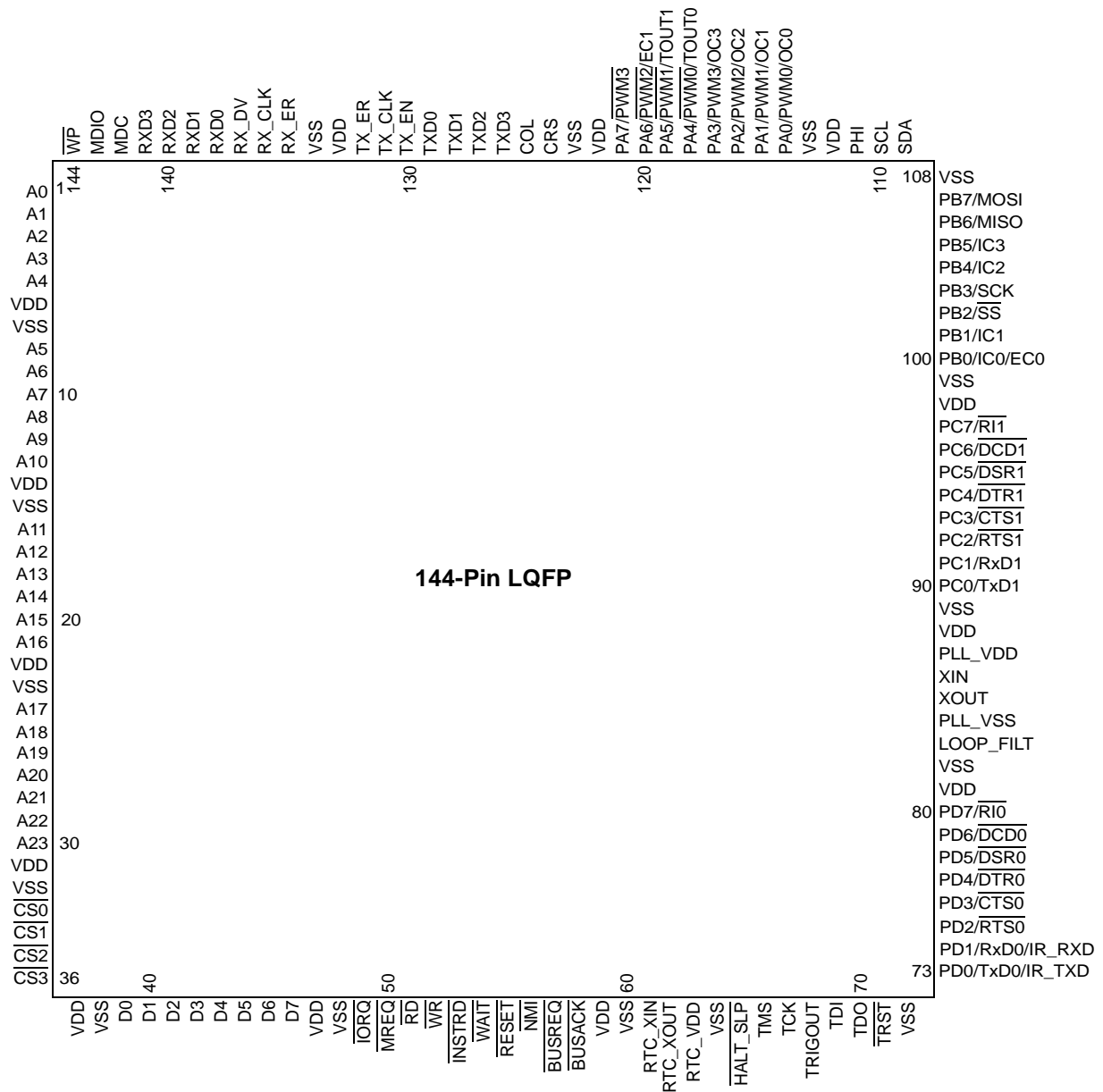

Figure 2. eZ80F91 MCU 144-Pin LQFP Pin Configuration

Table 2 lists the 144-pin BGA pin configuration of the eZ80F91 MCU.

Table 2. eZ80F91 144-Pin BGA Pin Configuration

	12	11	10	9	8	7	6	5	4	3	2	1
A	SDA	SCL	PA0	PA4	PA7	COL	TxD0	V _{DD}	Rx_DV	MDC	WPn	A0
B	V _{SS}	PHI	PA1	PA3	V _{DD}	TxD3	Tx_EN	V _{SS}	RxD1	MDIO	A2	A1
C	PB6	PB7	V _{DD}	PA5	V _{SS}	TxD2	Tx_CLK	Rx_CLK	RxD3	A3	V _{SS}	V _{DD}
D	PB1	PB3	PB5	V _{SS}	CRS	TxD1	Rx_ER	RxD2	A4	A8	A6	A7
E	PC7	V _{DD}	PB0	PB4	PA2	Tx_ER	RxD0	A5	A11	V _{SS}	V _{DD}	A10
F	PC3	PC4	PC5	V _{SS}	PB2	PA6	A9	A17	A15	A14	A13	A12
G	V _{SS}	PC0	PC1	PC2	PC6	PLL_V _{SS}	V _{SS}	A23	A20	V _{SS}	V _{DD}	A16
H	XOUT	XIN	PLL_V _{DD}	V _{DD}	PD7	TMS	V _{SS}	D5	V _{SS}	A21	A19	A18
J	V _{SS}	V _{DD}	LOOP_FILT_OUT	PD4	TRIGOUT	RTC_V _{DD}	NMI _n	WR _n	D2	CS0 _n	V _{DD}	A22
K	PD5	PD6	PD3	TDI	V _{SS}	V _{DD}	RESET _n	RD _n	V _{DD}	D1	CS2 _n	CS1 _n
L	PD1	PD2	TRST _n	TCK	RTC_XOUT	BUSAC _{Kn}	WAIT _n	MREQ _n	D6	D4	D0	CS3 _n
M	PD0	V _{SS}	TDO	HALT_SLP _n	RTC_XIN	BUSRE _{Qn}	INSTRD _n	IORQ _n	D7	D3	V _{SS}	V _{DD}

Figure 3 illustrates the bottom view of 144-pin eZ80F91 BGA Device.

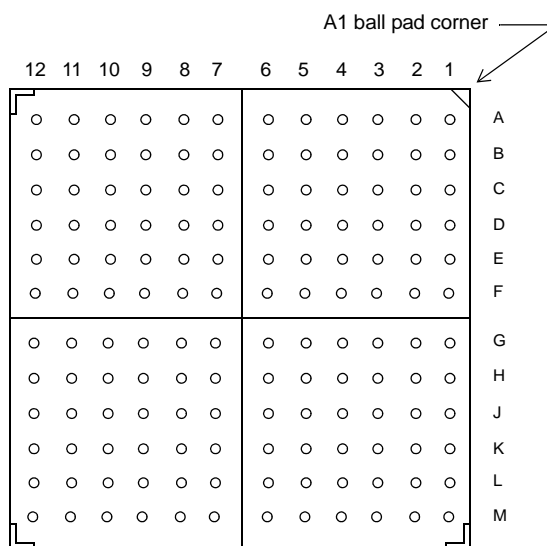

Figure 3. Bottom View of 144-Pin eZ80F91 BGA Device

Ordering Information

You can order the eZ80F91 MCU from Zilog using the part numbers listed in Table 3. For more information about ordering, please consult your

local Zilog sales office. For more information, or to download product collateral and software, please visit us at www.zilog.com.

Table 3. Ordering Information

Part Number	Description	Package
eZ80F91AZA50SG	eZ80F91 device, 50 MHz, Standard Temperature	144-LQFP
eZ80F91AZA50EG	eZ80F91 device, 50 MHz, Extended Temperature	144-LQFP
eZ80F91NAA50SG	eZ80F91 device, 50 MHz, Standard Temperature	144-BGA
eZ80F91NAA50EG	eZ80F91 device, 50 MHz, Extended Temperature	144-BGA
eZ80F91AZ050SG*	eZ80F91 device, 50 MHz, Standard Temperature	144-LQFP
eZ80F91AZ050EG*	eZ80F91 device, 50 MHz, Extended Temperature	144-LQFP
eZ80F91NA050SG*	eZ80F91 device, 50 MHz, Standard Temperature	144-BGA
eZ80F91NA050EG*	eZ80F91 device, 50 MHz, Extended Temperature	144-BGA
eZ80F910300KITG	eZ80AcclaimPlus! Development Kit	
eZ80F910300ZCOG	eZ80F91 Development Kit	
eZ80F910200KITG	eZ80F91 Modular Development Kit	
eZ80F916050MODG	Ethernet Module	
eZ80F916005MODG	Mini-Ethernet Module	
ZUSBSC00100ZACG	USB Smart Cable Accessory Kit	
ZENETSC0100ZACG	Ethernet Smart Cable Accessory Kit	

Note: *Denotes parts not recommended for new designs.



Warning: DO NOT USE THIS PRODUCT IN LIFE SUPPORT SYSTEMS.

LIFE SUPPORT POLICY

ZILOG'S PRODUCTS ARE NOT AUTHORIZED FOR USE AS CRITICAL COMPONENTS IN LIFE SUPPORT DEVICES OR SYSTEMS WITHOUT THE EXPRESS PRIOR WRITTEN APPROVAL OF THE PRESIDENT AND GENERAL COUNSEL OF Zilog CORPORATION.

As used herein

Life support devices or systems are devices which (a) are intended for surgical implant into the body, or (b) support or sustain life and whose failure to perform when properly used in accordance with instructions for use provided in the labeling can be reasonably expected to result in a significant injury to the user. A critical component is any component in a life support device or system whose failure to perform can be reasonably expected to cause the failure of the life support device or system or to affect its safety or effectiveness.

Document Disclaimer

©2012 Zilog, Inc. All rights reserved. Information in this publication concerning the devices, applications, or technology described is intended to suggest possible uses and may be superseded. Zilog, INC. DOES NOT ASSUME LIABILITY FOR OR PROVIDE A REPRESENTATION OF ACCURACY OF THE INFORMATION, DEVICES, OR TECHNOLOGY DESCRIBED IN THIS DOCUMENT. Zilog ALSO DOES NOT ASSUME LIABILITY FOR INTELLECTUAL PROPERTY INFRINGEMENT RELATED IN ANY MANNER TO USE OF INFORMATION, DEVICES, OR TECHNOLOGY DESCRIBED HEREIN OR OTHERWISE. The information contained within this document has been verified according to the general principles of electrical and mechanical engineering.

eZ80, eZ80Acclaim! and eZ80Acclaim*Plus!* are trademarks or registered trademarks of Zilog, Inc. All other product or service names are the property of their respective owners.