



Catalog 2013

ABB Safety Handbook

Machine Safety - Jokab Safety products

ABB Safety Handbook

Machine Safety - Jokab Safety products

Introduction Directives and Standards, PL, SISTEMA, SIL, Training	1
Pluto Safety PLC Pluto, Gateway, Safe Encoder, IDFIX, program examples	2
Pluto AS-i Pluto AS-i, Urax	3
Pluto Manager Software for programming of Pluto	4
Vital and Tina safety systems Vital, Tina, connection examples	5
Safety Relays RT series, JSB series, Safety timers, Expansion relays, connection examples	6
Light curtains/Light grids/Light beams Focus, Spot, Bjorn, WET, BP-1, connection examples	7
Stop time measurement and machine diagnosis Smart, Smart Manager	8
Sensors/Switches/Locks Eden, Sense, Magne, Dalton, Knox, MKey	9
Control devices JSHD4, Safeball, JSTD20	10
Emergency stop devices INCA, Smile, Smile Tina, Compact, EStrong, LineStrong	11
Contact Edges/Bumpers/Safety mats Contact Edges, Bumper, Mats, electrical connections	12
Fencing systems Quick-Guard, Quick-Guard Express, SafeCAD, Roller doors	13

Introduction

We develop innovative products and solutions for machine safety	1/4
Safety history	1/6
Directives and Standards	1/8
Working method as specified in EN ISO 13849-1	1/14
Case studies	1/18
What defines a safety function?	1/24
SISTEMA	1/26
Safety relay, Vital or Pluto?	1/27
Applying EN 62061	1/28
A mechanical switch does not give a safe function!	1/29
We train you on safety requirements	1/30

We develop innovative products and solutions for machine safety

1

We make it simple to build safety systems. Developing innovative products and solutions for machine safety has been our business idea since the company Jokab Safety, now ABB AB, was founded in Sweden in 1988. Our vision is to become “Your partner for machine safety – globally and locally”.

Many industries around the world, have discovered how much easier it has become to build protection and safety systems with our components and guidance.

Experience

We have great experience of practical application of safety requirements and standards from both authorities and production. We represent Sweden in standardisation organisations for machine safety and we work daily with the practical application of safety requirements in combination with production requirements. You can use our experience for training and advice.



Mats Linger and Torgny Olsson founded Jokab Safety AB in Sweden in 1988, together with Gunnar Widell

Systems

We deliver everything from a safety solution to complete safety systems for single machines or entire production lines. We combine production demands with safety demands for production-friendly solutions.

Products

We market a complete range of safety products, which makes it easy to build safety systems. We develop these innovative products continuously, in cooperation with our customers. Our extensive program of products, safety solutions and our long experience in machine safety makes us a safe partner.

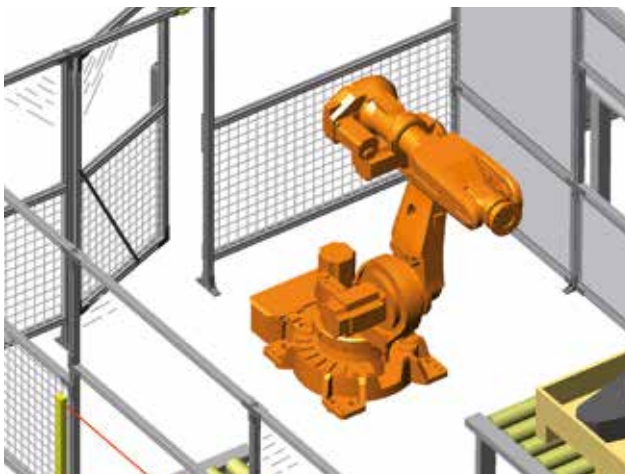

Do you need to learn about the new safety requirements for robots? If so, please contact us.

Standards and regulations

We help to develop standards

Directives and standards are very important to machinery and safety component manufacturers. We therefore participate in several international committees that develop standards, for among other things industrial robots, safety distances and control system safety features. This is experience that we absorb so that the standards will present requirements that benefit production efficiency allied to a high level of safety. We are happy to share our knowledge of standards with our customers.

Our products revolutionise the market

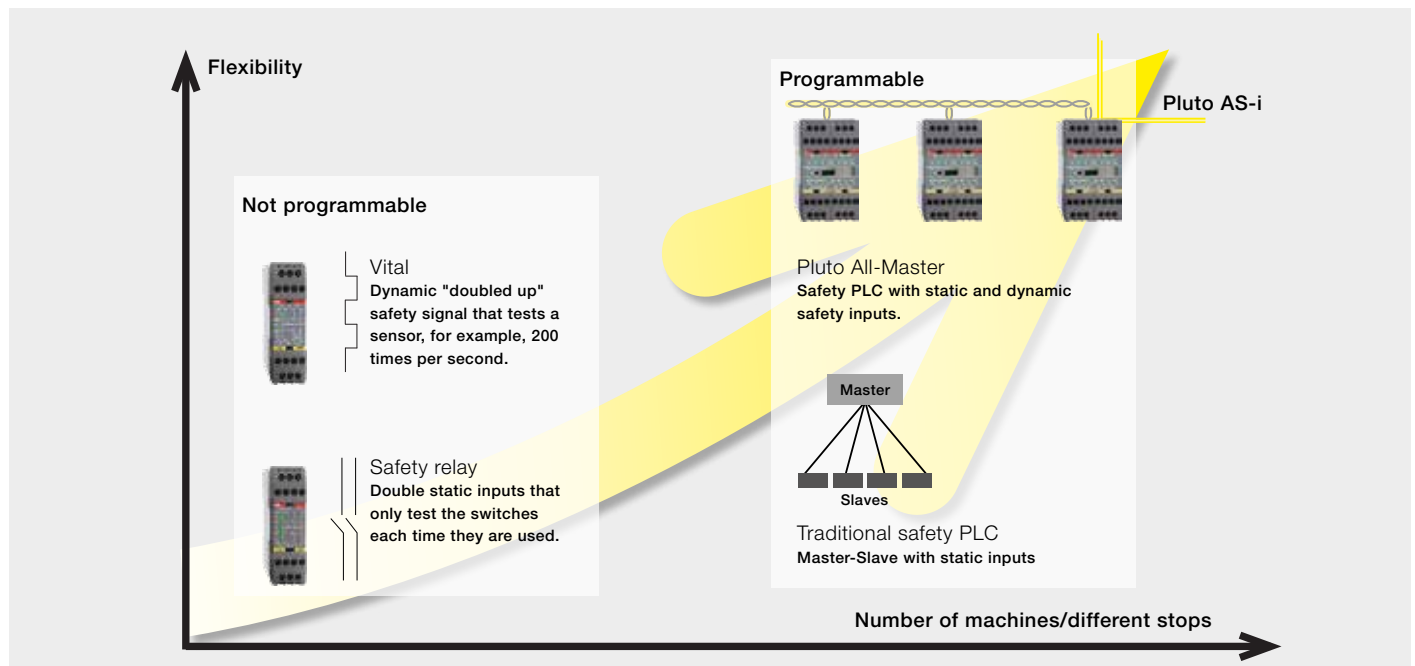

Our dynamic safety circuits and our comprehensive safety PLC are probably the most revolutionary ideas that have happened in the safety field in the control and supervision of protection, in many respects:

- They save on inputs: a dual safety circuit with one conductor instead of two. In addition, many protection devices can be connected to the same input while maintaining the highest level of safety.
- Reliability is better. Our electronic sensors have much longer lives than mechanical switches
- They are safer, since our dynamic safety sensors are checked 200 times per second. Traditional switches on a door can only be checked each time they are used, for example once per hour or even once a month.

- With the All-Master Safety PLC it is easy to connect and disconnect machinery from a safety viewpoint. Common emergency stop circuits and sensors can be created as soon as the buses are interconnected between our safety PLCs.

We are continuously designing safety systems for difficult environments and also to create new safety solutions where practical solutions are missing. New technical improvements give new possibilities and therefore we continuously develop new products.

We train both machine builders and machine operators

Do you construct machinery?

We can provide the training you need to construct machinery that meets the requirements. Example subjects:

- Practical implementation of the requirements in the new Machinery Directive 2006/42/EC, which is valid for machines that was delivered/put into service from the 29th of december 2009
- Risk analysis – in theory and practice
- Control systems safety, standards EN ISO 13849-1 and EN 62061

Do you purchase and use machinery?

As a machinery user it is your responsibility to ensure that the correct requirements are complied with – regardless of whether your machinery is “new” or “old”, i.e. CE-labelled or not. Unfortunately many have purchased CE-labelled machinery that does not meet the requirements. This must not be used. Having it brought into compliance by the supplier can take a long time and be expensive in terms of loss of production, etc. We can educate you on this and help you to set the right demands when buying new or even second-hand machinery.

Safety history

Developments of the 70's

Our background in safety started in the seventies when there was a significant focus on the safety of manually operated presses, the most dangerous machine in those days. The probability of loosing a finger or hand while working with these machines was very high. New safety solutions for both safety devices as well as for the control systems for presses were developed and introduced on both old and new machines. We were directly involved in this work through the design of Two-Hand devices, control systems for presses, making safety inspections for the Health and Safety authorities and writing regulations for safety of these machines. This work provided an excellent base for our knowledge in machinery safety.

The numbers of accidents involving presses decreased significantly during these years however there is still room for new ideas to enable safety equipment become more practical and ergonomic.

Developments of the 80's

During the eighties, industrial robots (Irb's) started to become commonplace in manufacturing industry. This meant that workers were outside of the dangerous areas during production but had at certain times to go inside the machine in order to e.g. adjust a product to the correct position, inspect the production cycle, troubleshoot and to programme the Irb. New risks were introduced and new safety methods required. It was for example hard to distinguish whether production machines had stopped safely or simply waiting for the next signal, such as a sensor giving a start signal while a product was being adjusted into the correct position. Mistakes in safety system design resulting in serious accidents were made, such as the omission of safety devices to stop the Irb, unreliable connection of safety devices and unreliable safety inputs on the Irb.

In the mid eighties the standards committee for safety in Industrial Robot Systems EN 775/ISO 775 was started. This was the first international standard for machine safety. In order to give the correct inputs to the standard, work around Irb's was closely studied in order to meet production integrated safety requirements. The introduction of a production oriented safety stop function was made, using for example, software to stop machines smoothly and then safety relays/contactors to disconnect the power to the machines actuators after the machine had stopped. This technique allows easy restart of production after a stop situation by the machine safeguards.

There were a lot of discussions as to whether one could have both safety and practical requirements in a standard, such as a safe stop function, which allowed an easy restart of the machine. Three-position enabling devices were also introduced for safety during programming, testing and trouble shooting of Irb's and other equipment. In the robot standard the three-position enabling function was first defined by only allowing for hazardous machinery functions in the mid switch position. Releasing or pressing the three-position push button in panic leading to a stop signal.

Developments of the 90's

In Europe, during the nineties, the machinery directive was the start of a tremendous increase in co-operation across borders to get European standards for safety for machinery and safety devices. The experience from different European countries has led to a wide range of safety standards and this has made work in safety much easier. With the integration of Europe it is now only necessary for a safety company such as ourselves to get one approval for our components for all of Europe instead of one per country.

Developments 2000 –

Internationally the work on safety has now been intensified within ISO. The objective is to have the same structure of safety requirements and standards within ISO as within EN. ABB Jokab Safety is active both internationally and nationally in different standard working groups. The co-operation between countries is leading to better safety solutions, making it much easier to create safe working environments around the world.

...of the 70's



We protected people from loosing fingers or/and hands in dangerous machines.

...of the 80's



Three-position enabling devices were also introduced for safety during programming.

...of the 90's



European standards for safety for machinery and safety devices.

...2000 –

Jokab Safety's developments



Jokab Safety's first safety relay



Jokab Safety's first steel fencing system

...of the 80's

1



Timer reset and first light beam

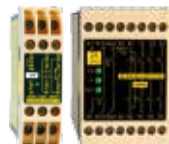

Smallest safety relays JSBT5 and JSBR4



RT series universal relays

...of the 90's



Three-position switch for robots



3-position devices



Safeball - ergonomic control device



Stop time measurement



SafeCad for Quick-Guard



Quick-Guard aluminium fencing system

Pluto All-Master safety PLC

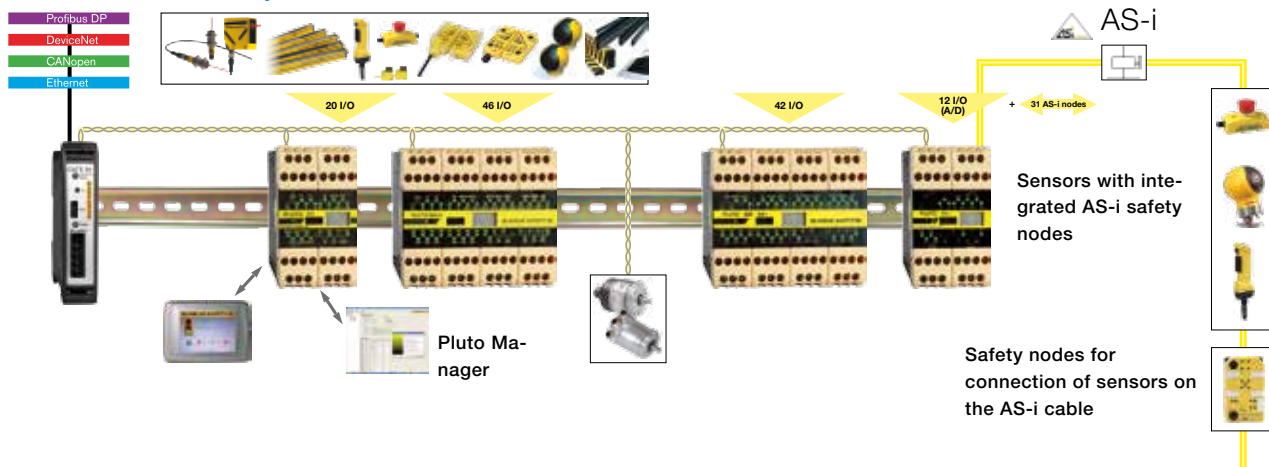

...2000 -

Vital with dynamic safety circuits

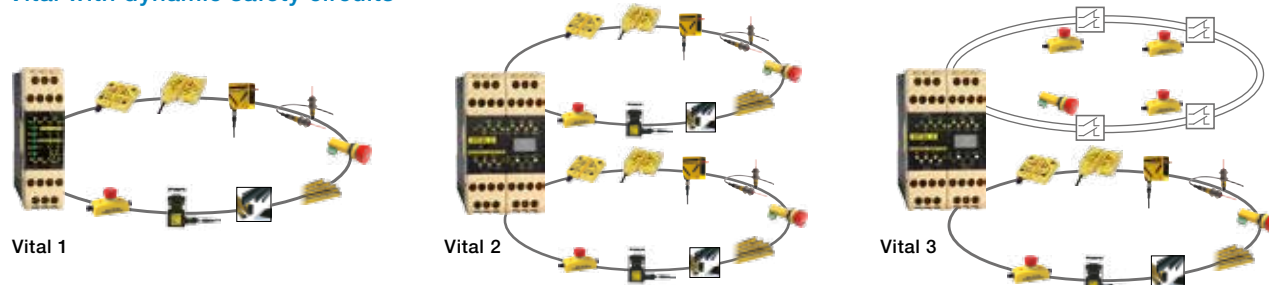

Non-contact sensor Eden, guard locks, Focus light beam, E-stops Inca and Smile, Smart for machine diagnosis and three-position device with hand detection



Directives and Standards

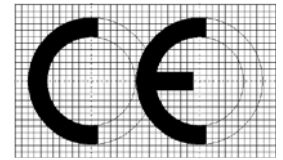

1

Directives and standards are of great importance for manufacturers of machines and safety components. EU Directives giving requirements for the minimum level of health and safety are mandatory for manufacturers to fulfil. In every member country the Directives are implemented in each countries legislation.

Machines which have been put on the market since december 29, 2009, must comply with the new Machinery Directive 2006/42/EC. Before that, the old Machinery Directive 98/37/EC was valid.

The objectives of the Machinery Directive, 2006/42/EC, are to maintain, increase and equalise the safety level of machines within the members of the European Community. Based on this, the free movement of machines/products between the countries in this market can be achieved. The Machinery Directive is developed according to "The New Approach" which is based on the following principles:

- The directives give the basic health and safety requirements, which are mandatory.
- Detailed solutions and technical specifications are found in harmonised standards.
- Standards are voluntary to apply, but products designed according to the harmonised standards will fulfil the basic safety requirements in the Machinery Directive.

Harmonised standards

Harmonised standards give support on how to fulfil the requirements of the Machinery Directive. The relationship between the Machinery Directive and the harmonised standards is illustrated by the diagram below.

Within ISO (The International Organization for Standardization) work is also going on in order to harmonise the safety standards globally in parallel with the European standardisation work.

ABB Jokab Safety takes an active part in the working groups both for the ISO and EN standards.

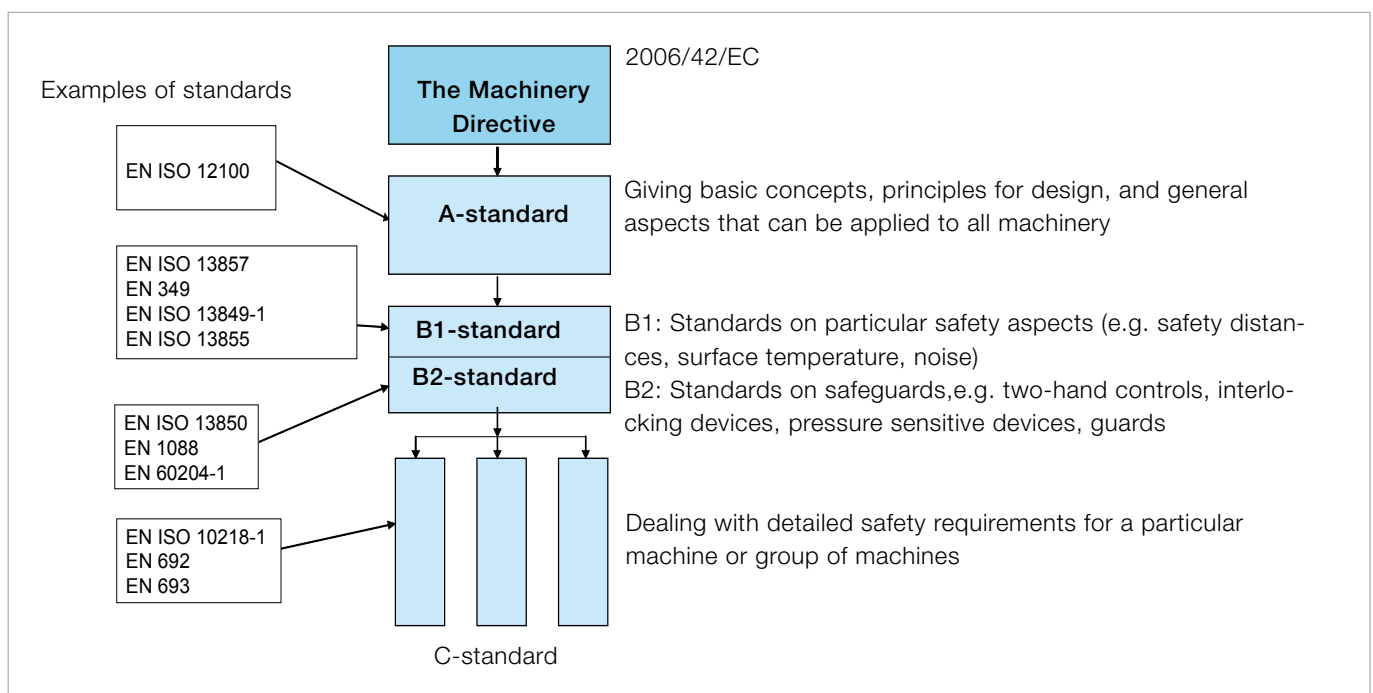

The Machinery Directive; for machines and safety components

From 2006/42/EC

- 1 §** This Directive applies to the following products:
- a)** machinery;
 - b)** interchangeable equipment;
 - c)** safety components;
 - d)** lifting accessories;
 - e)** chains, ropes and webbing;
 - f)** removable mechanical transmission devices;
 - g)** partly completed machinery.

The Machinery Directive gives the following definition:

a) machinery' means:

- an assembly, fitted with or intended to be fitted with a drive system other than directly applied human or animal effort, consisting of linked parts or components, at least one of which moves, and which are joined together for a specific application,
- an assembly referred to in the first indent, missing only the components to connect it on site or to sources of energy and motion,
- an assembly referred to in the first and second indents, ready to be installed and able to function as it stands only if mounted on a means of transport, or installed in a building or a structure,
- assemblies of machinery referred to in the first, second and third indents or partly completed machinery referred to in point (g) which, in order to achieve the same end, are arranged and controlled so that they function as an integral whole,
- an assembly of linked parts or components, at least one of which moves and which are joined together, intended for lifting loads and whose only power source is directly applied human effort;

CE-marking and Declaration of conformity

Machines manufactured or put on the market from December 29, 2009, shall be CE-marked and fulfil the requirements according to the European Machinery Directive 2006/42/EC. This is also valid for old machines (manufactured before 1 January 1995) if they are manufactured in a country outside the EEA and imported to be used in a country in the EEA.

For machines manufactured and/or released to the market between January 1, 1995, and December 28, 2009, the old Machinery Directive (98/37/EC) is valid.

NOTE! The point in time when the Machinery Directive was implemented in each Member Country varies. Machines have to be accompanied by a Declaration of Conformity (according to 2006/42/EC, Annex II 1.A) that states which directive and standards the machine fulfils. It also shows if the product has gone through EC Type Examination.

Safety components have to be accompanied with a Declaration of Conformity.

Requirements for the use of machinery

For a machine to be safe it is not enough that the manufacturer has been fulfilling all valid/necessary requirements. The user of the machine also has requirements to fulfil. For the use of machinery there is a Directive, 89/655/EEC (with amendment 96/63/EC and 2001/45/EC).

About CE-marked machinery the Directive gives the following requirement

From 89/655/EEC (with amendment 96/63/EC and 2001/45/EC)

1. Without prejudice to Article 3, the employer must obtain and/or use:

(a) work equipment which, if provided to workers in the undertaking and/or establishment for the first time after 31 December 1992, complies with:

- (i) the provisions of any relevant Community directive which is applicable;
- (ii) the minimum requirements laid down in Annex I, to the extent that no other Community directive is applicable or is so only partially;

This means that when repair/changes are made on the machine it shall still fulfil the requirements of the Machinery Directive. This doesn't have to mean that a new CE-marking is required. (Can be required if the changes are extensive)

NOTE! This means that the buyer of a machine also has to make sure that a new machine fulfils the requirements in the directives. If the machine does not fulfil the requirements the buyer is not allowed to use it.

"Old" machines

For machines delivered or manufactured in the EEA before 1 January 1995 the following is valid.

(b) work equipment which, if already provided to workers in the undertaking and/or establishment by 31 December 1992, complies with the minimum requirements laid down in Annex I no later than four years after that date.

(c) without prejudice to point (a) (i), and notwithstanding point (a) (ii) and point (b), specific work equipment subject to the requirements of point 3 of Annex I, which, if already provided to workers in the undertaking and/or establishment by 5 December 1998, complies with the minimum requirements laid down in Annex I, no later than four years after that date.

Annex I contains minimum requirements for health and safety. There can also be additional national specific requirements for certain machines. NB The point in time when the Machinery Directive was implemented in each Member Country varies. Therefore it is necessary to check with the national authorities in one's own country, to find out what is considered as "old" and respectively "new" machines.

"Old" machines

Machine that is put on the market or put into service before 1995 in the EEA.



Council Directive 89/655/EEC (with amendment 96/63/EC and 2001/45/EC) concerning the minimum safety and health requirements for the use of work equipment by workers at work.

Possible national legislation on specific machines

"New" machines

1. Machine that is put on the market or put into service after 1/1 1995 in the EEA.

2. All machines that are imported to the EEA irrespective of date of origin.

CE-marking + Declaration of conformity



Council Directive 89/655/EEC (with amendment 96/63/EC and 2001/45/EC) concerning the minimum safety and health requirements for the use of work equipment by workers at work. N.B! Not annex 1, instead use applicable directives.

Low Voltage Directive 2006/95/EC

The Machinery Directive 98/37/EC (Jan 1, 1995 - Dec 28, 2009) 2006/42/EC (from December 29, 2009)

EMC-directive 2004/108/EC

Possibly more directives

Risk assessment – an important tool both when constructing a new machine and when assessing risks on older machines

A well thought-out risk assessment supports manufacturers/users of machines to develop production friendly safety solutions. One result of this is that the safety components will not be a hindrance. This minimizes the risk of the safety system being defeated.

New machines

The following requirement is given by the Machinery Directive

The manufacturer of machinery or his authorised representative must ensure that a risk assessment is carried out in order to determine the health and safety requirements which apply to the machinery. The machinery must then be designed and constructed taking into account the results of the risk assessment.

The standard EN ISO 12100 gives guidance on the information required to allow risk assessment to be carried out. The standard does not point out a specific method to be used. It is the responsibility of the manufacturer to select a suitable method.

Machines in use

Risk assessment must be carried out on all machines that are in use; CE-marked as well as not CE-marked.

To fulfil the requirements from Directive 89/655/EEC (concerning the minimum safety and health requirements for the use of work equipment by workers at work) risk assessment have to be made.

Documentation of risk assessment

The risk assessment shall be documented. In the assessment the actual risks shall be analysed as well as the level of seriousness.

Protection or warning?

How is it possible to choose safety measures that are production friendly and in every way well balanced? The Machinery Directive gives an order of priority for the choice of appropriate methods to remove the risks. Here it is further developed in a five step method.

Prioritize safety measures according to the five step method

1. Eliminate or reduce risks by design and construction
2. Move the work tasks outside the risk area
3. Use guards/safety devices
4. Develop safe working routines/information/education
5. Use warnings as pictograms, light, sound etc.

The further from middle of the circle, the greater the responsibility for the safety is put onto the user of the machine. If full protection is not effectively achieved in one step, one has to go to the next step and find complementary measures.

What is possible is dependant on the need for accessibility, the seriousness of the risk, appropriate safety measures etc.

Example on prioritizing according to the 5-step-method

Priority	Example of hazard and safety measure taken	
1. Make machine safe by design and construction	Hazard:	Cuts and wounds from sharp edges and corners on machinery
	Safety measure:	Round off sharp edges and corners.
2. Move the work tasks outside the risk area	Hazard:	Crushing of fingers from machine movements during inspection of the production inside the risk area
	Safety measure:	Installation of a camera.
3. Use guard/safety devices	Hazard:	Crushing injuries because of unintended start during loading of work pieces in a mechanical press
	Safety measure:	Install a light curtain to detect operator and provide safe stop of the machinery.
4. Safe working routines/information	Hazard:	Crushing injuries because the machine can tip during installation and normal use.
	Safety measure:	Make instructions on how the machine is to be installed to avoid the risks. This can include requirements on the type of fastening, ground, screw retention etc.
5. Warnings	Hazard:	Burns because of hot surfaces in reach
	Safety measure:	Warning signs

The possibilities will increase to achieve a well thought-through safety system if each risk is handled according to the described prioritizing.

Combine the five step method with production friendly thinking. This can give you e.g.

- fast and easy restart of machines after a stop from a safety device
- enough space to safely program a robot
- places outside the risk area to observe the production
- electrically interlocked doors, instead of guards attached with screws, to be able to take the necessary measures for removing production disturbances
- a safety system that is practical for all types of work tasks, even when removing production disturbances

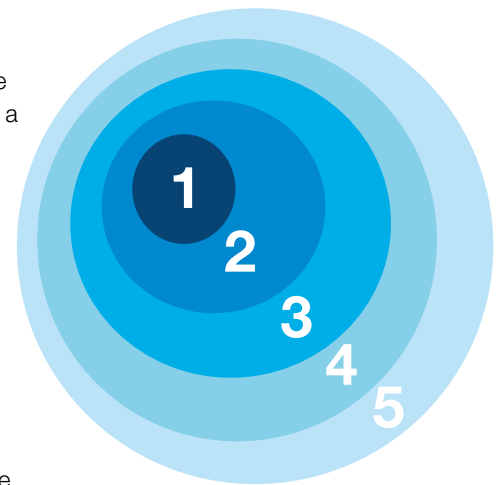

Examples of regularly used EN/ISO standards

1

EN ISO 12100 (replaces EN ISO 12100-1/-2 and EN ISO 14121-1)	Safety of machinery - General principles for design - Risk assessment and risk reduction	Part 1: This standard defines basic terminology and methodology used in achieving safety of machinery. The provisions stated in this standard are intended for the designer. Part 2: This standard defines technical principles to help designers in achieving safety in the design of machinery.
EN ISO 13857	Safety of machinery - Safety distances to prevent hazard zones being reached by upper and lower limbs	This standard establishes values for safety distances to prevent danger zones being reached by the upper limbs. The distances apply when adequate safety can be achieved by distances alone.
EN 349 (ISO 13854)	Safety of machinery – Minimum gaps to avoid crushing of parts of the human body	The object of this standard is to enable the user (e.g. standard makers, designers of machinery) to avoid hazards from crushing zones. It specifies minimum gaps relative to parts of the human body and is applicable when adequate safety can be achieved by this method.
EN ISO 13850	Safety of machinery – Emergency stop – Principles for design	This standard specifies design principles for emergency stop equipment for machinery. No account is taken of the nature of the energy source.
EN 574	Safety of machinery – Two-hand control devices – Functional aspects – Principles for design	This standard specifies the safety requirements of a two-hand control device and its logic unit. The standard describes the main characteristics of two-hand control devices for the achievement of safety and sets out combinations of functional characteristics for three types.
EN 953	Safety of machinery – Guards – General requirements for the design and construction of fixed and movable guards	This standard specifies general requirements for the design and construction of guards provided primarily to protect persons from mechanical hazards.
EN ISO 13849-1 (replaces EN 954-1)	Safety of machinery – Safety related parts of control systems – Part 1: General principles for design	This standard provides safety requirements and guidance on the principles for the design (see 3.11 of EN 292-1:1991) of safety-related parts of control systems. For these parts it specifies categories and describes the characteristics of their safety functions. This includes programmable systems for all machinery and for related protective devices. It applies to all safety-related parts of control systems, regardless of the type of energy used, e.g. electrical, hydraulic, pneumatic, mechanical. It does not specify which safety functions and which categories shall be used in a particular case.
EN ISO 13849-2	Safety of machinery. Safety-related parts of control systems. Validation	This standard specifies the procedures and conditions to be followed for the validation by analysis and testing of: <ul style="list-style-type: none"> • the safety functions provided, and • the category achieved of the safety-related parts of the control system in compliance with EN 954-1 (ISO 13849-1), using the design rationale provided by the designer.
EN 62061	Safety of machinery. Functional safety of safety-related electrical, electronic and programmable electronic control systems	The standard defines the safety requirements and guiding principles for the design of safety-related electrical/electronic/programmable parts of a control system.
EN ISO 13855 (replaces EN 999)	Safety of machinery - Positioning of safeguards with respect to the approach speeds of parts of the human body	This standard provides parameters based on values for hand/arm and approach speeds and the methodology to determine the minimum distances from specific sensing or actuating devices of protective equipment to a danger zone.
EN 1088 and EN 1088/A1	Safety of machinery. Interlocking devices associated with guards. Principles for design and selection	This standard specifies principles for the design and selection - independent of the nature of the energy source - of interlocking devices associated with guards. It also provides requirements specifically intended for electrical interlocking devices. The standard covers the parts of guards which actuate interlocking devices.
EN 60204-1	Safety of machinery. Electrical equipment of machines. General requirements	This part of IEC 60204 applies to the application of electrical and electronic equipment and systems to machines not portable by hand while working, including a group of machines working together in a co-ordinated manner but excluding higher level systems aspects (i.e. communications between systems).

New standards for safety in control systems

Building a protection system that works in practice and provides sufficient safety requires expertise in several areas. The design of the safety functions in the protection system in order to ensure they provide sufficient reliability is a key ingredient. As help for this there is, for example, the EN ISO 13849-1 standard. The purpose of this text is to provide an introduction to the standard and its application in conjunction with our products.

Introducing the new standard

The generation change for standards on safety in control systems introduces new concepts and calculations for machine builders and machine users. The EN 954-1 standard has been phased out and is replaced by EN ISO 13849-1 (PL, Performance Level) and EN 62061 (SIL, Safety Integrity Level).

PL or SIL? What should I use?

The standard you should use depends on the choice of technology, experience and customer requirements.

Choice of technology

- PL (Performance Level) is a technology-neutral concept that can be used for electrical, mechanical, pneumatic and hydraulic safety solutions.
- SIL (Safety Integrity Level) can, however, only be used for electrical, electronic or programmable safety solutions.

Experience

EN ISO 13849-1 uses categories from EN 954-1 for defining the system structure, and therefore the step to the new calculations is not so great if you have previous experience of the categories. EN 62061 defines the structures slightly differently.

Customer requirements

If the customer comes from an industry that is accustomed to using SIL (e.g. the process industry), requirements can also include safety functions for machine safety being SIL rated.

We notice that most of our customers prefer PL as it is technology-neutral and that they can use their previous knowledge in the categories. In this document we show some examples of how to build safety solutions in accordance with EN ISO 13849-1 and calculate the reliability of the safety functions to be used for a particular machine. The examples in this document are simplified in order to provide an understanding of the principles. The values used in the examples can change.

What is PL (Performance Level)?

PL is a measure of the reliability of a safety function. PL is divided into five levels (a-e). PL e gives the best reliability and is equivalent to that required at the highest level of risk.

To calculate which level the PL system achieves you need to know the following:

- The system's structure (categories B, 1-4)
- The Mean Time To dangerous Failure of the component ($MTTF_d$)
- The system's Diagnostic Coverage (DC)

You will also need to:

- protect the system against a failure that knocks out both channels (CCF)
- protect the system from systematic errors built into the design
- follow certain rules to ensure software can be developed and validated in the right way

The five PL-levels (a-e) correspond to certain ranges of PFH_D -values (probability of dangerous failure per hour). These indicate how likely it is that a dangerous failure could occur over a period of one hour. In the calculation, it is beneficial to use PFH_D -values directly as the PL is a simplification that does not provide equally accurate results.

What is the easiest way of complying with the standard?

1. Use pre-calculated components.

As far as it is possible, use the components with pre-calculated PL and PFH_D -values. You then minimise the number of calculations to be performed. All ABB Jokab Safety products have pre-calculated PFH_D -values.

2. Use the calculation tool.

With the freeware application SISTEMA (see page 16) you avoid making calculations by hand. You also get help to structure your safety solutions and provide the necessary documentation.

3. Use Pluto or Vital

Use the Pluto safety PLC or Vital safety controller. Not only is it easier to make calculations, but above all it is easier to ensure a higher level of safety.

Working method as specified in EN ISO 13849-1

1

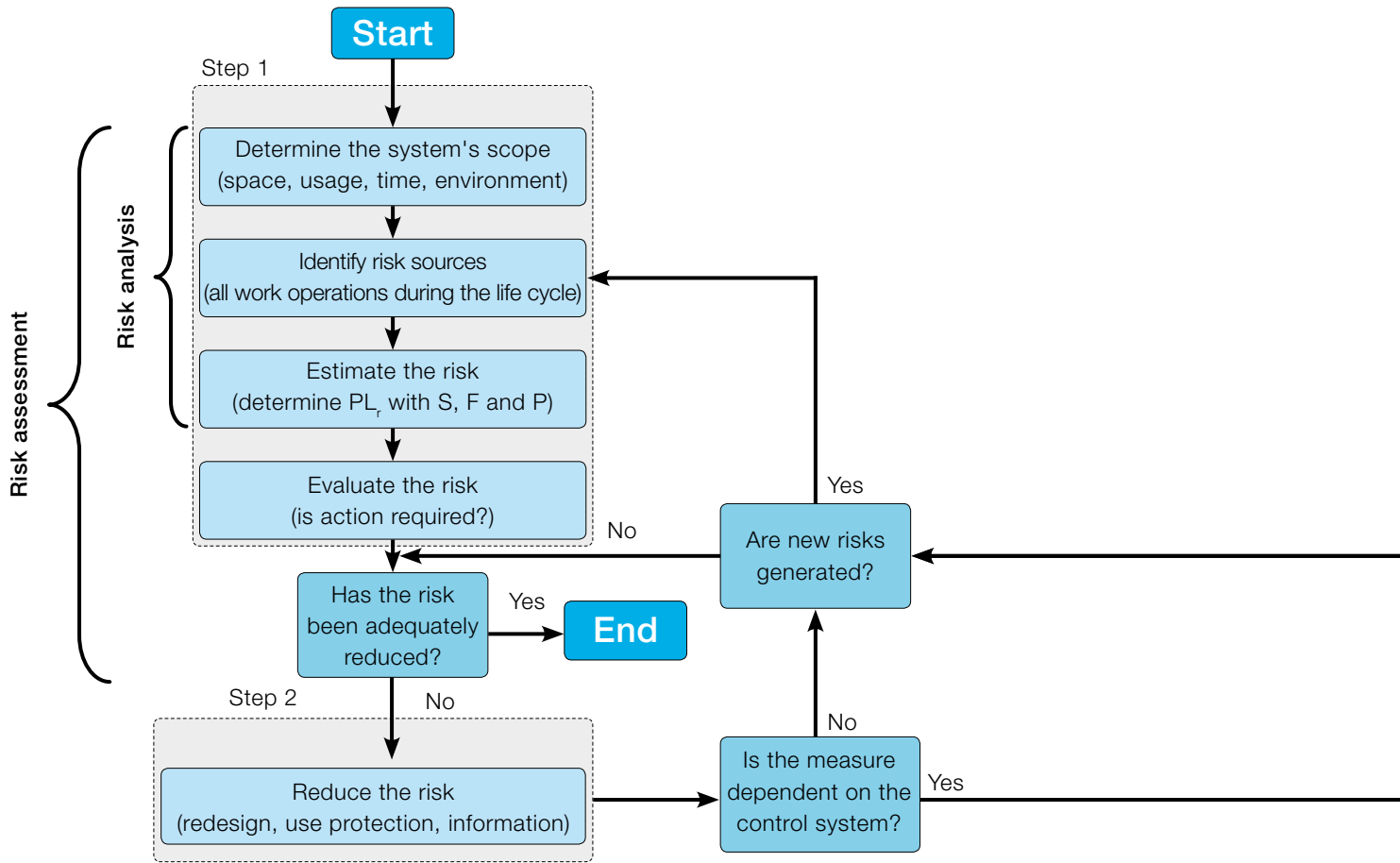

Risk assessment and risk minimisation

According to the Machinery Directive, the machine builder (anyone who builds or modifies a machine) is required to perform a risk assessment for the machine design and also include an assessment of all the work operations that need to be performed. The EN ISO 12100 standard (combination of EN ISO 14121-1 and EN ISO 12100-1/-2) stipulates the requirements for the risk assessment of a machine. It is this that EN ISO 13849-1 is based on, and a completed risk assessment is a prerequisite for being able to work with the standard.

Step 1 – Risk assessment

A risk assessment begins with determining the scope of the machine. This includes the space that the machine and its operators need for all of its intended applications, and all operational stages throughout the machine's life cycle.

All risk sources must then be identified for all work operations throughout the machine's life cycle.

A risk estimation is made for each risk source, i.e. indication of the degree of risk. According to EN ISO 13849-1 the risk

is estimated using three factors: injury severity (S, severity), frequency of exposure to the risk (F, frequency) and the possibility you have of avoiding or limiting the injury (P, possibility). For each factor two options are given. Where the boundary between the two options lies is not specified in the standard, but the following are common interpretations:

- S1** **bruises, abrasions, puncture wounds and minor crushing injuries**
- S2** **skeletal injuries, amputations and death**
- F1** **less frequently than every two weeks**
- F2** **more often than every two weeks**
- P1** **slow machine movements, plenty of space, low power**
- P2** **quick machine movements, crowded, high power**

By setting S, F and P for the risk, you will get the PL_r Performance Level (required) that is necessary for the risk source.

Finally, the risk assessment includes a risk evaluation where you determine if the risk needs to be reduced or if sufficient safety is ensured.

Risk estimation

To calculate the performance level required (PL_r).

S	Severity of injury
S1	slight (normally reversible injury)
S2	serious (normally irreversible injury or death)
F	Frequency and/or exposure to hazard
F1	seldom to less often and/or exposure time is short
F2	frequent to continuous and/or exposure time is long
P	Possibility of avoiding hazard or limiting harm
P1	possible under specific conditions
P2	scarcely possible

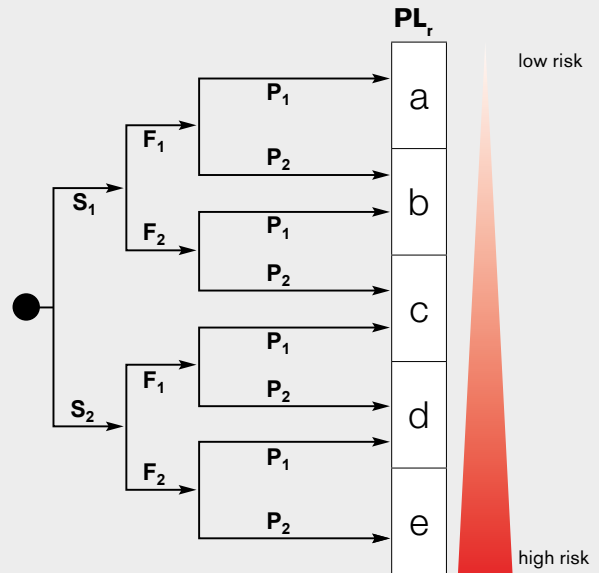

Step 2 – Reduce the risk

If you determine that risk reduction is required, you must comply with the priority in the Machinery Directive in the selection of measures:

1. Avoid the risk already at the design stage. (For example, reduce power, avoid interference in the danger zone.)
2. Use protection and/or safety devices. (For example, fences, light grids or control devices.)
3. Provide information about how the machine can be used safely. (For example, in manuals and on signs.)

If risk reduction is performed using safety devices, the control system that monitors these needs to be designed as specified in EN ISO 13849-1.

Step 3 - Design and calculate the safety functions

To begin with you need to identify the safety functions on the machine. (Examples of safety functions are emergency stop and monitoring of gate.)

For each safety function, a PL_r should be established (which has often already been made in the risk assessment). The solution for the safety function is then designed and implemented. Once the design is complete, you can calculate the PL the safety function achieves. Check that the calculated PL is at least as high as PL_r and then validate the system as per the validation plan. The validation checks that the specification of the system is carried out correctly and that the design complies with the specification. You will also need to verify that the requirements that are not included in the calculation of the PL are satisfied, that is, ensure that the software is properly developed and validated, and that you have taken adequate steps to protect the technical solution from systematic errors.

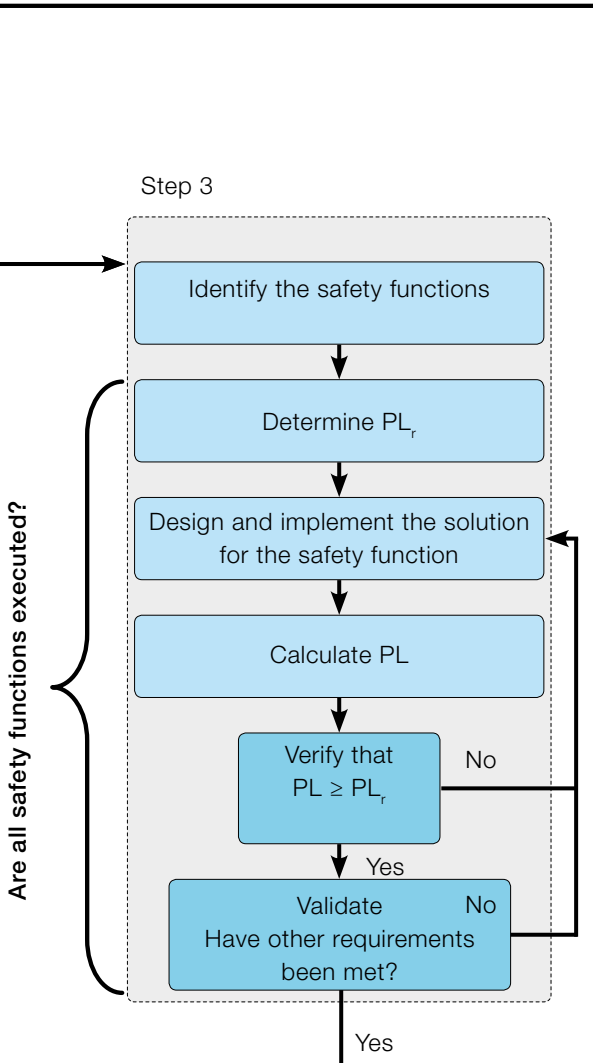

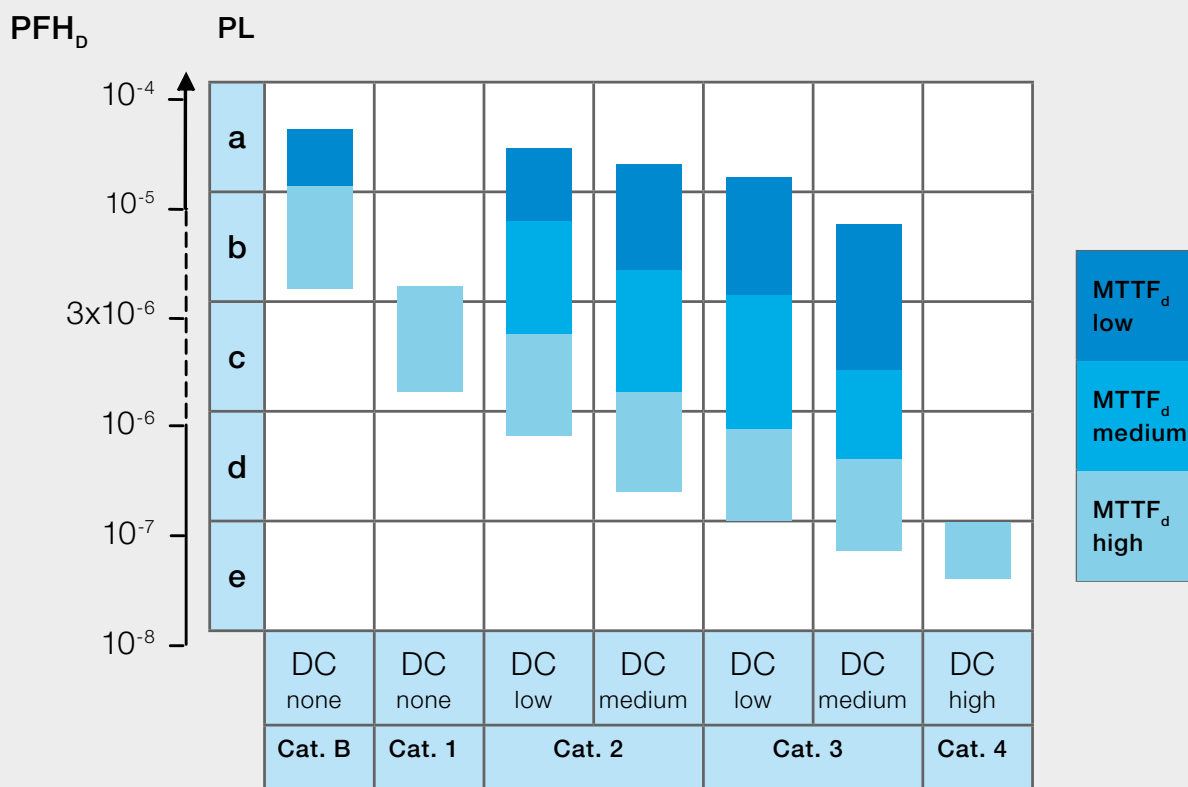

The relationship between categories, the DC_{avg}, MTTF_d for each channel and PL. The table also shows the PFH_D-range that corresponds to each PL.

PL calculation in Step 3

When you calculate the PL for a safety function, it is easiest to split it into separate, well defined blocks (also called subsystems). It is often logical to make the breakdown according to input, logic and output (e.g. switch - safety relay - contactors), but there may be more than three blocks depending on the connection and the number of components used (an expansion relay could for example create an additional logic block).

For each block, you calculate a PL or PFH_D-value. It is easiest if you obtain these values from the component manufacturer, so you do not have to calculate yourself. The manufacturer of switches, sensors and logic devices often have PL and PFH_D-values for their components, but for output devices (such as

contactors and valves) you do not usually specify a value as it depends on how often the component will be used. You can then either calculate yourself according to EN ISO 13849-1 or use the pre-calculated example solutions such as those from ABB Jokab Safety.

To calculate PL or PFH_D for a block, you need to know its category, DC and MTTF_d. In addition, you need to protect yourself against systematic errors and ensure that an error does not knock out both channels, and generate and validate any software used correctly. The following text gives a brief explanation of what to do.

Safety function (SF)

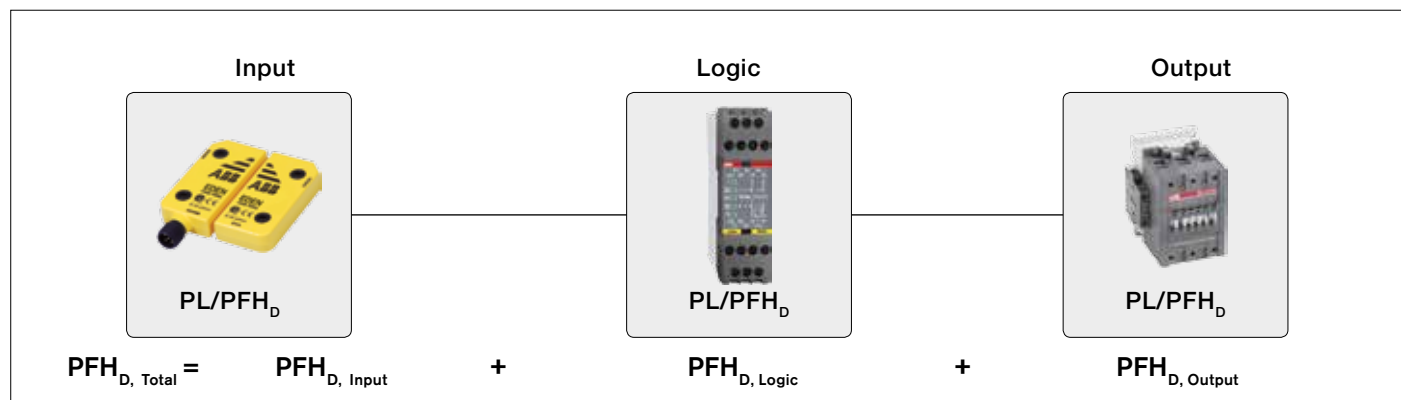

Category

The structure for the component(s) in the block is assessed to determine the category (B, 1-4) it corresponds to. For category 4, for example, individual failures do not result in any loss of the safety function.

In order to achieve category 4 with contactors, you need to have two channels - i.e., two contactors - that can cut the power to the machine individually. The contactors need to be monitored by connecting opening contacts to a test input on, for example a safety relay. For monitoring of this type to work, the contactors need to have contacts with positive opening operation.

Diagnostic Coverage (DC)

A simple method to determine DC is explained in Appendix E in EN ISO 13849-1. It lists various measures and what they correspond to in terms of DC. For example, DC=99 % (which corresponds to DC high) is achieved for a pair of contactors by monitoring the contactors with the logic device.

Mean Time To dangerous Failure (MTTF_d)

The MTTF_d-value should primarily come from the manufacturer. If the manufacturer cannot provide values, they are given from tables in EN ISO 13849-1 or you have to calculate MTTF_d using the B_{10d}-value, (average number of cycles until 10% of the components have a dangerous failure). To calculate the MTTF_d, you also need to know the average number of cycles per year that the component will execute.

Calculation of the average number of cycles is as follows:

$$MTTF_d = \frac{B_{10d}}{0,1 \cdot n_{op}}$$

where

$$n_{op} = \frac{d_{op} \cdot h_{op} \cdot 3600}{t_{cycle}}$$

- n_{op} = Number of cycles per year
- d_{op} = Operation days per year
- h_{op} = Operation hours per day
- t_{cycle} = Cycle time (seconds)

Example: d_{op} = 365 days, h_{op} = 24 hours and t_{cycle} = 1,800 seconds (2 times/hour) which gives n_{op} = 17,520 cycles. With a B_{10d} = 2·10⁶ this gives a MTTF_d = 1,141 year which corresponds to MTTF_d = high.

Note that when you calculate MTTF_d you have to calculate according to the total number of cycles the component will be working. A typical example of this is the contactors that frequently work for several safety functions simultaneously. This means that you must add the number of estimated cycles per year from all the safety functions that use the contactors.

When MTTF_d is calculated from a B_{10d}-value, also consider that if the MTTF_d-value is less than 200 years, the component needs to be replaced after 10% of the MTTF_d-value (due to the T_{10d}-value). That is, a component with MTTF_d = 160 years needs to be replaced after 16 years in order for the conditions for achieving PL to continue to be valid. This is because EN ISO 13849-1 is based on a “mission time” of 20 years.

Common Cause Failure (CCF)

In Appendix F of EN ISO 13849-1 there is a table of actions to be taken to protect against CCF, to ensure a failure does not knock out both channels.

Systematic errors

Appendix G of EN ISO 13849-1 describes a range of actions that need to be taken to protect against incorporating faults into your design.

PL for safety functions

PL is given in the table on the facing page. If you want to use an exact PFH_D-value instead, this can be produced using a table in Appendix K in EN ISO 13849-1.

Once you have produced the PL for each block, you can generate a total PL for the safety function in Table 11 of EN ISO 13849-1. This gives a rough estimate of the PL. If you have calculated PFH_D for each block instead, you can get a total of PFH_D for the safety function by adding together all the values of the blocks. The safety function's total PFH_D corresponds to a particular PL in Table 3 of EN ISO 13849-1.

Requirements for safety-related software

If you use a safety PLC for implementing safety functions, this places demands on how the software is developed and validated. To avoid error conditions, the software should be readable, understandable and be possible to test and maintain.

A software specification must be prepared to ensure that you can check the functionality of the program. It is also important to divide the program into modules that can be tested individually. Paragraph 4.6 and Appendix J of EN ISO 13849-1 specify requirements for safety related software.

The following are examples of requirements for software from EN ISO 13849-1:

- A development life cycle must be produced with validation measures that indicate how and when the program should be validated, for example, following a change.
- The specification and design must be documented.
- Function tests must be performed.
- Validated functional blocks must be used whenever possible.
- Data and control flow are to be described using, for example, a condition diagram or software flow chart.

Protection layout for a packaging machine with low risks.

1

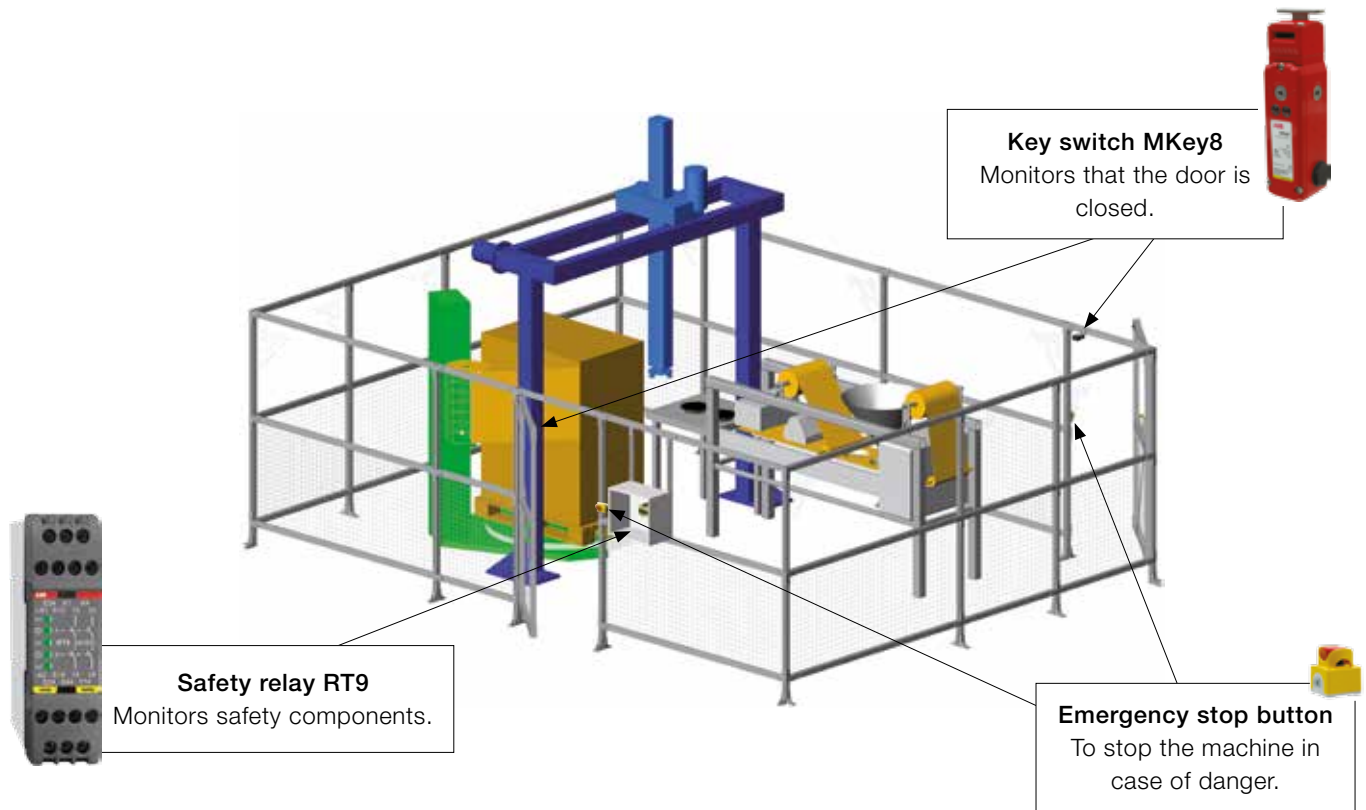

Step 1 – Risk assessment

Food to be packaged is loaded into the cell manually through the rear door. A batch is prepared for the packing conveyor in the infeed hopper. The cell is reset and restarted. The packaging machine with conveyor belt only operates when both doors are closed and when the protection system has been reset.

In the risk assessment it was established that the machine is to be operated in three shifts (8 hours per shift) 365 days a year. It is assumed that operational disturbances were resolved in less than one minute in the danger zone. This can be carried out two times per hour (F2). Unexpected start-ups are not deemed to cause serious injury but rather minor healable injuries (S1). The operator is deemed not to have the possibility of avoiding injury as the machine moves quickly (P2).

The number of cycles for the safety function = 365 days/year • (3•8) hours/day • 2 cycles/hour = 17,520 cycles/year
 The assessment for the safety function required for access to the machine is $PL_r = c$ (S1, F2, P2). In addition to this safety function, an emergency stop function is needed. This is also assessed as $PL_r = c$.

Step 2 – Reduce the risk

As protection, an interlocked door is selected with the key switch MKey8. Downtime is short enough for the dangerous movement to have stopped before the operator can access it. The emergency stop is placed within easy reach, on both sides of the cell near the locked doors.

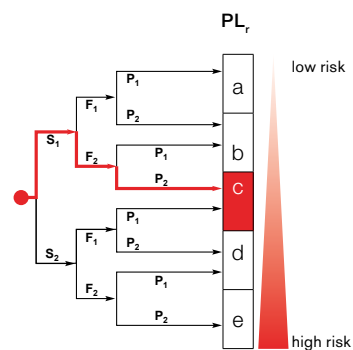

Assessment of the PL_r necessary for the safety function with interlocked door for this example.

NOTE! The assessment needs to be made for each safety function.

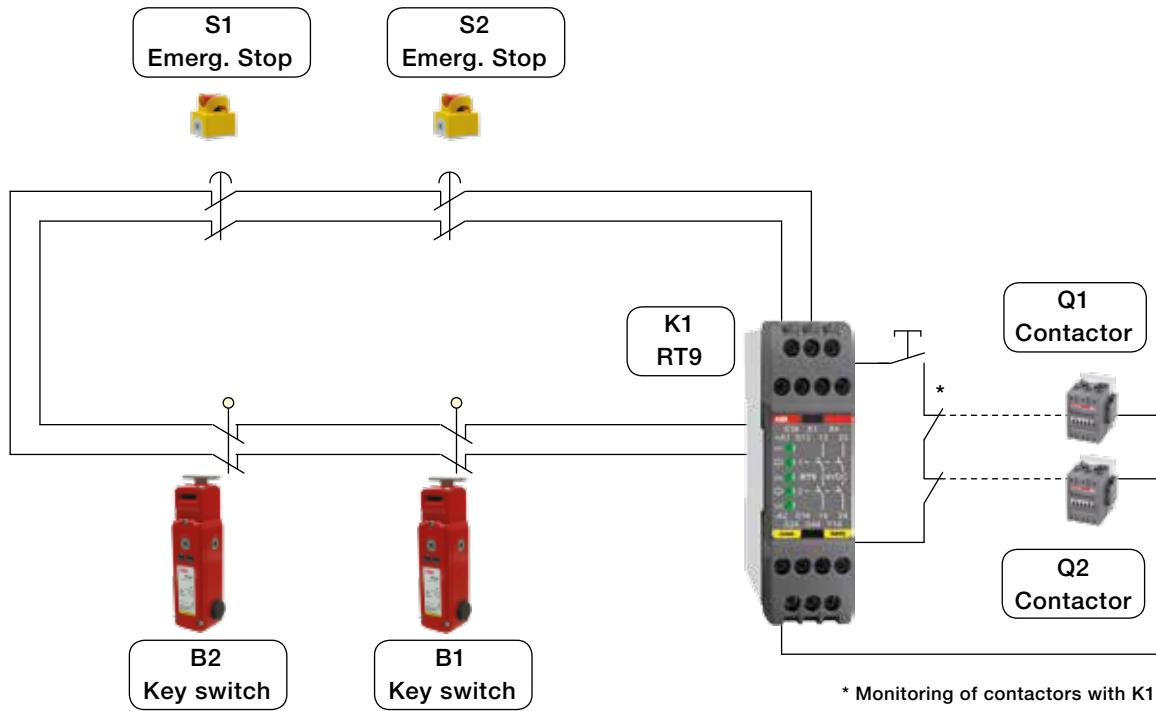

Step 3 - Calculate the safety functions

The starting block that is composed of double unmonitored contactors has been calculated at $2.47 \cdot 10^{-8}$. The safety functions are represented by block diagrams.

Safety functions 1 and 2 are identical. Therefore, only safety function 1 is shown.

Safety functions 3 and 4 are identical. Therefore, only safety function 3 is shown.

How safe is a mechanical switch?

A mechanical switch must be installed and used according to its specifications in order to be reliable.

- Life expectancy only applies if correctly installed.
- The locking head must be fixed so that it will not loosen.
- The environment around the lock housing must be kept clean.
- Two mechanical switches on a door can also fail for the same reason.

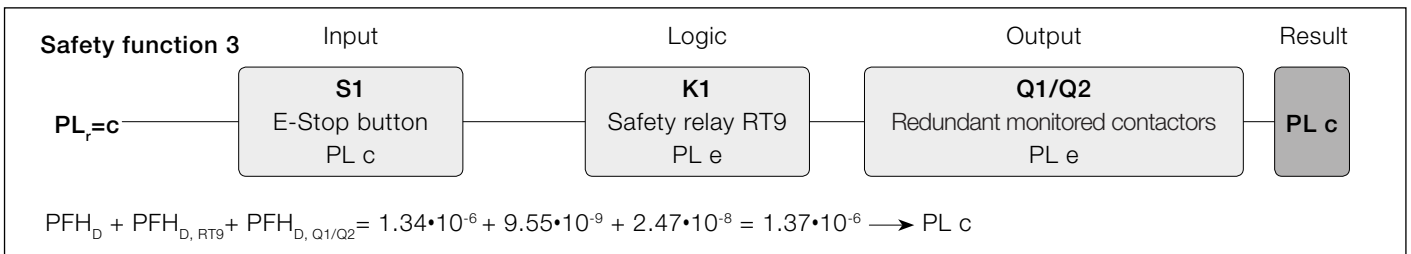
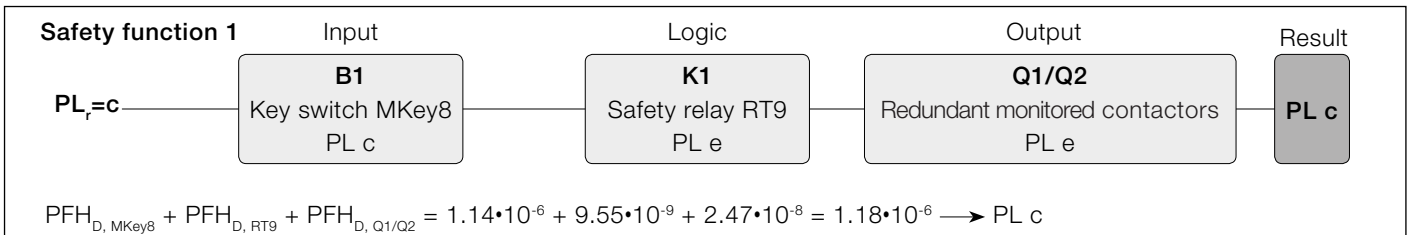

The reason for not achieving more than PL c with this solution is that you use one key switch per door. PL d could be achieved by using two key switches per door, but further action on the monitoring of each switch will be required as well. Note: If the risk assessment had shown that a serious injury, S2, could occur, the outcome would have been $PL_r=e$. This would have meant that the above solution was inadequate. For the emergency stop function, PL d can be achieved provided that certain failure exclusions can be made. These safety functions can be downloaded from our website as a SIS-TEMA project, www.abb.com/jokabsafety.

Protection layout for a robot cell with high risks.

1

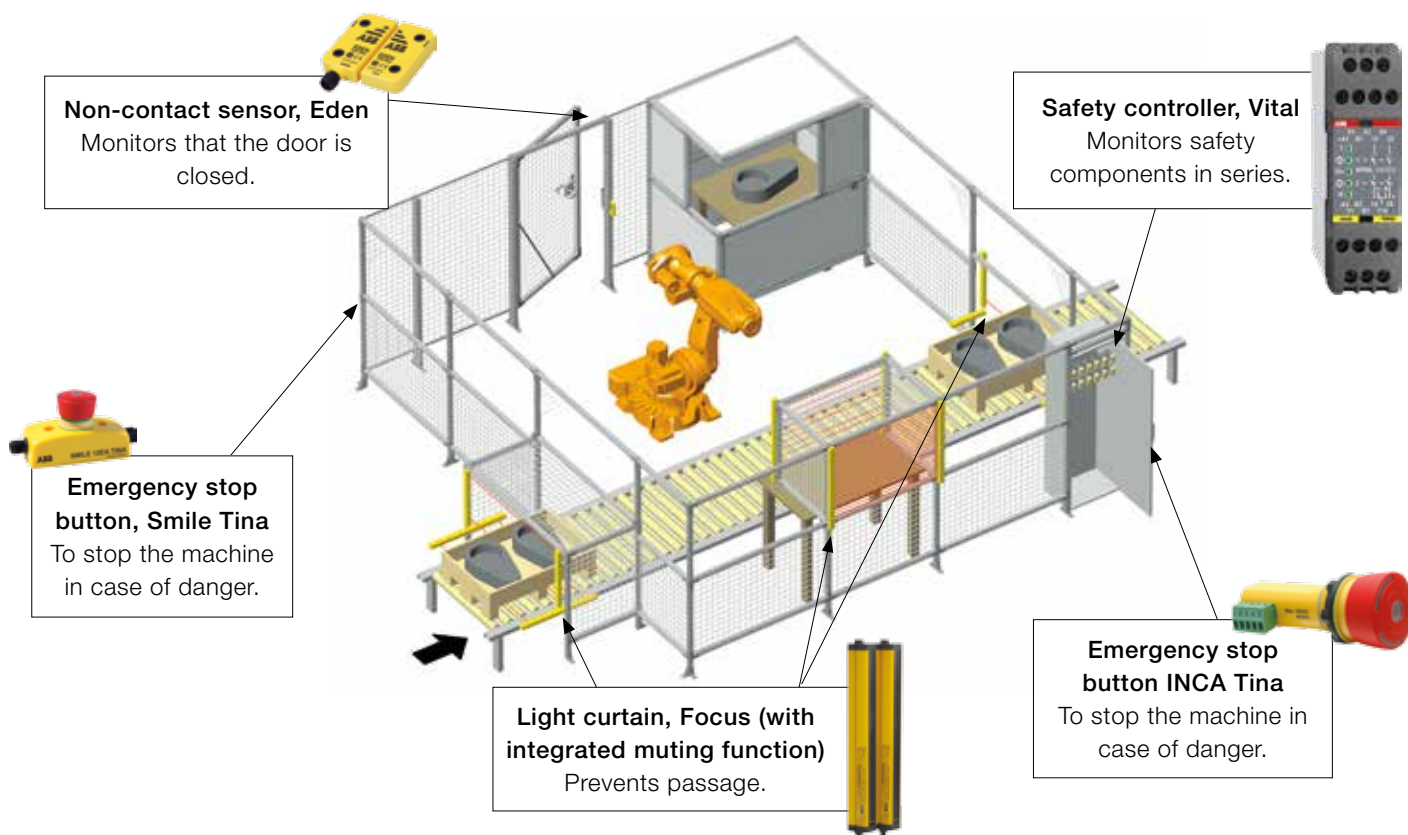

Step 1 – Risk assessment

The workpieces are fed into the equipment and transported out again following an error-free test. With the help of a robot the workpieces are added to a machine for testing. Unauthorised workpieces are positioned by the robot for post-machining in a manual discharge station. The work that needs to be done in the robot cell is to correct operational disturbances for the test equipment and the conveyor belt (about once an hour), post-machining and unloading from the manual station (about once an hour), program adjustments (once/week) and cleaning (once/week) (F2). Unexpected start-ups of the robot are expected to cause serious injury (S2). The operator is deemed not to have the possibility of avoiding injury as the robot moves quickly (P2). The assessment for the safety function required for access to the machine is $PL_r=e$ (S2, F2, P2).

The coming ISO 10218-2 standard for robot systems/cells specifies the requirement PL d for the safety functions to be used (if the risk analysis does not show a different PL). For the robot safety stop and emergency stop inputs, the requirement is at least PL d (according to the EN ISO 10218-1 standard). However, in this case risk assessment is $PL_r=e$.

Step 2 – Reduce the risk

As protection, an interlocked door is selected with the Eden non-contact sensor. To protect against entering the cell the wrong way, transport of materials in and out is protected and

provided with muting to distinguish between material and people. The emergency stop is also a safety function that is required. The power source to all hazardous machinery functions has to be cut using all safety functions.

The solution with Vital makes it possible to implement a robot application with only one safety controller, which does not need to be configured or programmed. Vital makes it possible to connect up to 30 safety functions in a single loop, with PL e in accordance with EN ISO 13849-1.

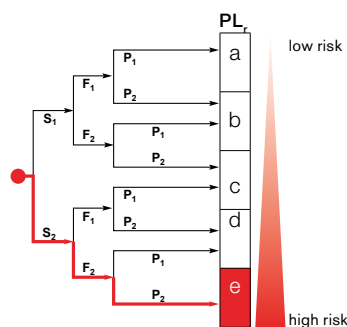

Assessment of the PL_r required for the safety function with interlocked door.

NOTE! The assessment needs to be made for each safety function.

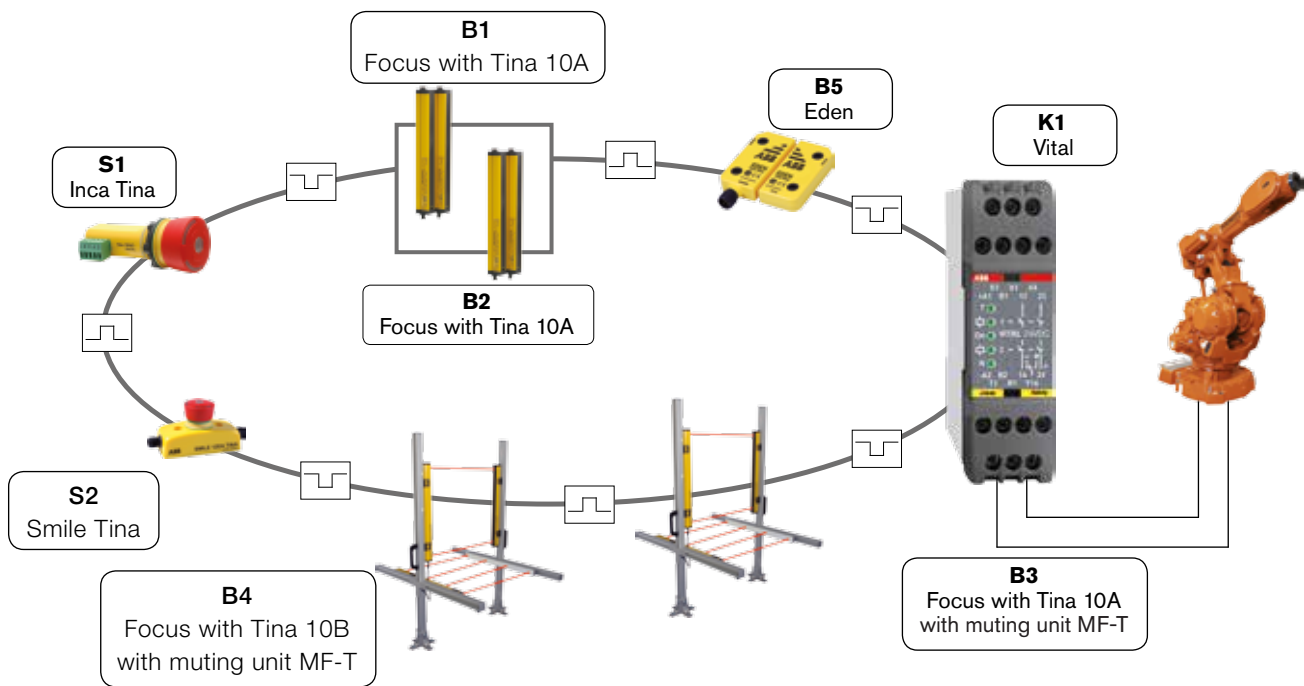

Step 3 - Calculate the safety functions

The PFH_D -value of the robot's safety stop input is $5.79 \cdot 10^{-8}$ (the value applies to ABB industrial robots with IRC5 controller). The safety functions are represented by block diagrams.

Safety function 3

When calculating the safety function the PFH_D - values for both the light curtain and the muting unit shall be included in the same function. See safety function 3 below.

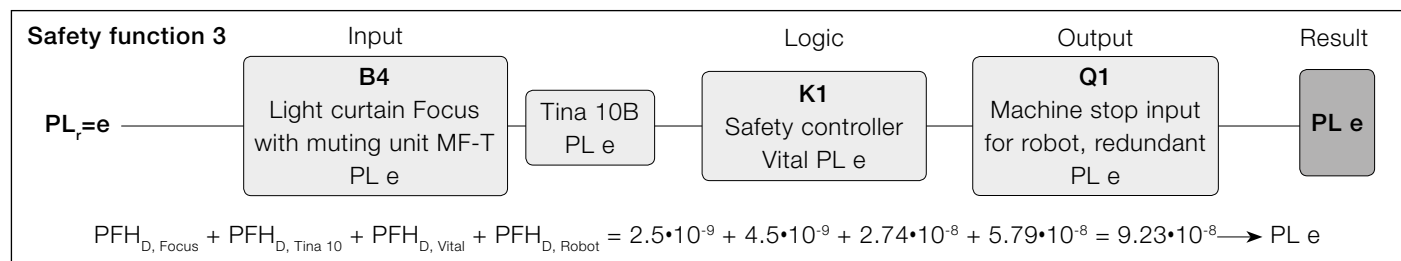
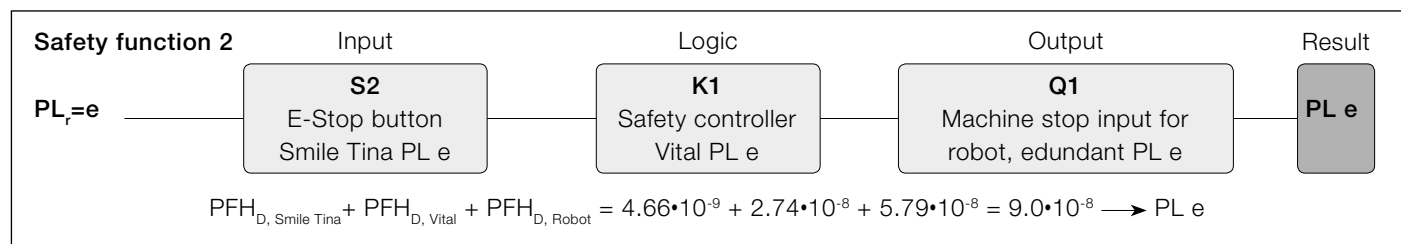
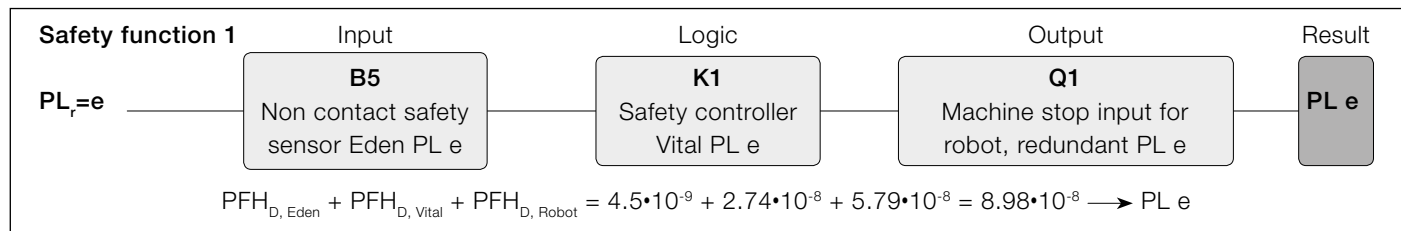

These safety functions with Vital meet PL e in accordance with EN ISO 13849-1. Note that the above functions are only selected examples of the safety functions that is represented in the robot cell.

Protection layout for a machining tool and industrial robot with high risks.

1

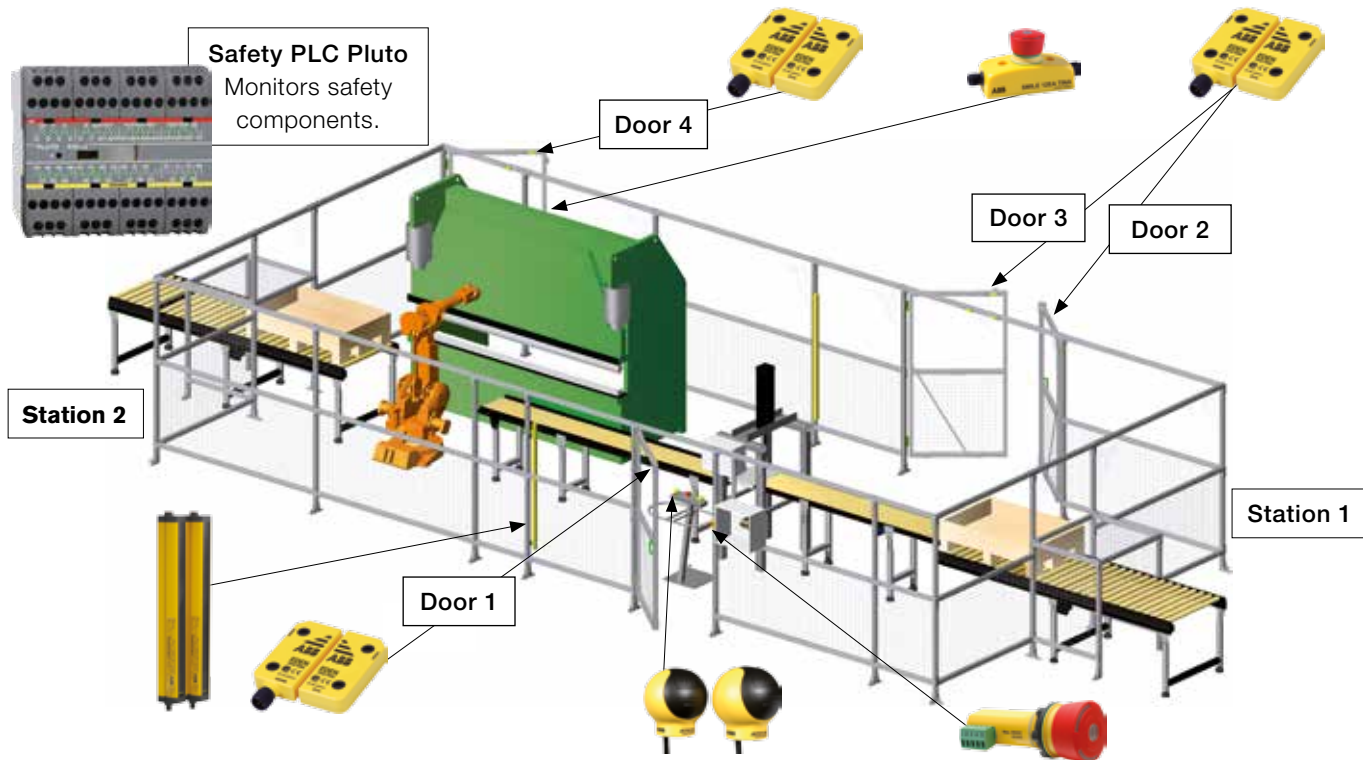

Step 1 – Risk assessment

The workpieces to be machined are fed into the cell through a conveyor belt and positioned by the operator in the pneumatic machining tool in station 1. The operator starts station 1 manually. The pneumatic machining tool performs work on the workpiece in station 1. The operator then places the machined workpiece on the conveyor belt for transfer to station 2. The robot then takes the workpiece that is placed in the hydraulic press. The workpiece leaves the cell by transport out onto the conveyor. The work that needs to be done in station 2 is, for example, to address operational disturbances in the press and the robot (a few times a week, F2).

Unexpected start-ups of the robot are expected to cause serious injury (S2). The operator is deemed not to have the possibility of avoiding injury as the robot moves quickly (P2). The assessment for the safety function required for access to station 2 is $PL_r=e$ (S2, F2, P2). This assessment would still be the same in respect of the press. For the safety function for the risks associated with the conveyor belt, the assessment S1, F2, P1 is made giving $PL_r= b$.

Step 2 – Reduce the risk

As protection, interlocked doors are selected with the Eden non-contact sensor. Station 1 with the pneumatic machining tool is operated by a two-hand device. When the two-hand device is released, the dangerous movement will be stopped safely. Station 2 can be in automatic mode, when a light

curtain (Focus) and a non-contact sensor at door 4 (Eden) protects the entry. If the door is opened or the light curtain is breached, station 2 stops in a safe manner. By opening doors 2 and 3 (also monitored by Eden) the conveyor belt and the pneumatic machining tool will stop safely. Manual reset must always be done after actuation by any safety device.

When the protection system requires a number of safety devices and that multiple machines must be checked, safety PLC Pluto is the most effective solution. If the protection system also has to work by zones and in different modes of operation, this is another compelling reason to use Pluto. With Pluto, PL_e can be achieved regardless of the number of connected safety devices.

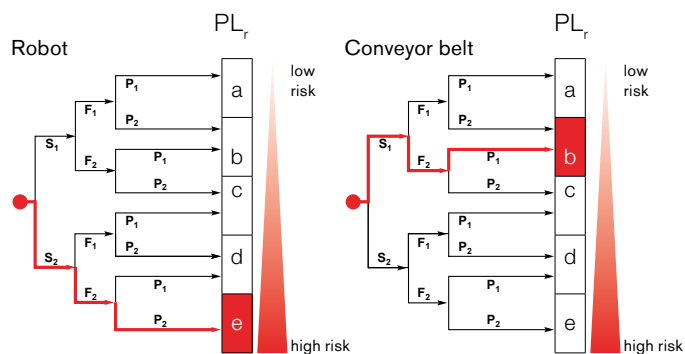

$PL_r= e$ for the robot and hydraulic press and $PL_r= b$ for the conveyor belt.

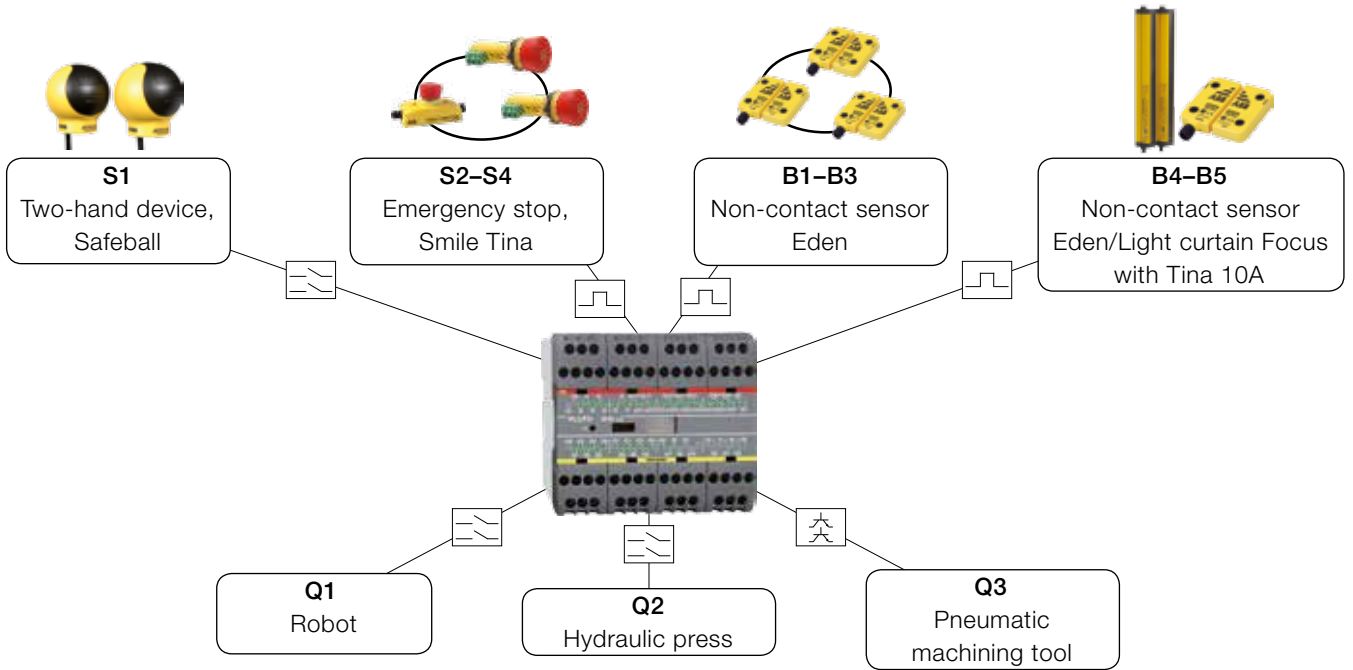

Step 3 - Calculate the safety functions for the robot cell

The PFH_D -value for the robot's safety stop input is $5.79 \cdot 10^{-8}$ (the value applies to ABB industrial robots with IRC5 controller).

Only safety functions to help cut the power to the industrial robot are shown below. This is only a subset of the safety functions. When the power is to be cut to multiple machines in a cell, the safety functions can be defined in different ways depending on the risk analysis. The safety functions are represented by block diagrams.

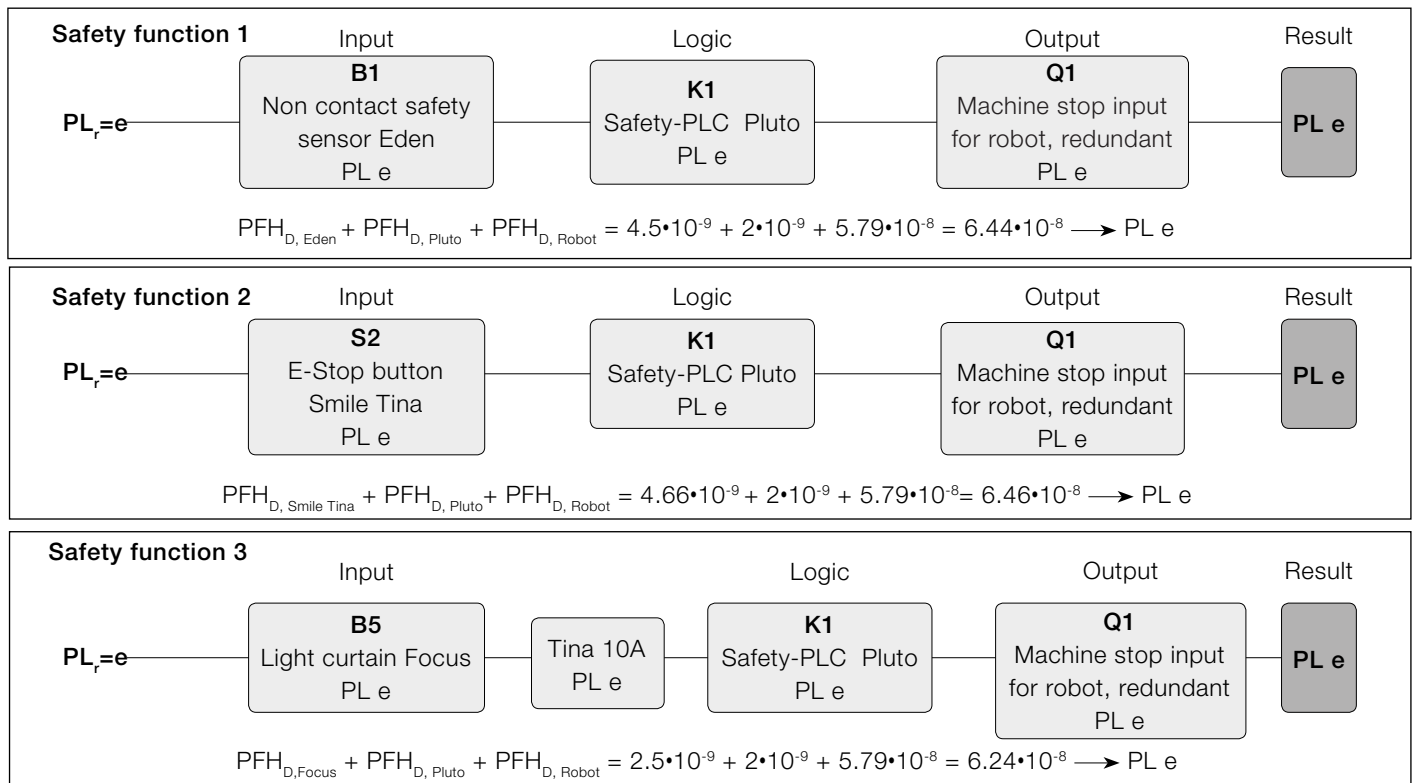

These safety functions with Pluto meet PL e in accordance with EN ISO 13849-1. Note that the above functions are only selected examples of the safety functions that appear in the robot cell.

What defines a safety function?

1

Calculating that you have achieved the PL_r that is required is not difficult, especially if you use “pre-calculated” safety devices and logic units. But what parts should then be included in each safety function?

This must be resolved before you start calculating phase. To summarise in simple terms you can say that each safety device gives rise to a safety function for each machine that is affected by the safety device in question. Three safety devices that all cut the power to three machines in a cell is therefore equal to nine safety functions. In the section that follows, we explain the background.

Multiple safety functions for a machine

Multiple safety devices are often used on a machine in order to provide satisfactory and practical protection for the operators. In the following example, the machine is protected by three safety devices connected to a logic device. The following figure illustrates this interconnection schematically.

Three safety functions (SF) are defined for the machine and are calculated as:

$$SF1: PFH_{D, F1} + PFH_{D, K1} + PFH_{D, Q1} = PFH_{D, SF1}$$

$$SF2: PFH_{D, B1} + PFH_{D, K1} + PFH_{D, Q1} = PFH_{D, SF2}$$

$$SF3: PFH_{D, S1} + PFH_{D, K1} + PFH_{D, Q1} = PFH_{D, SF3}$$

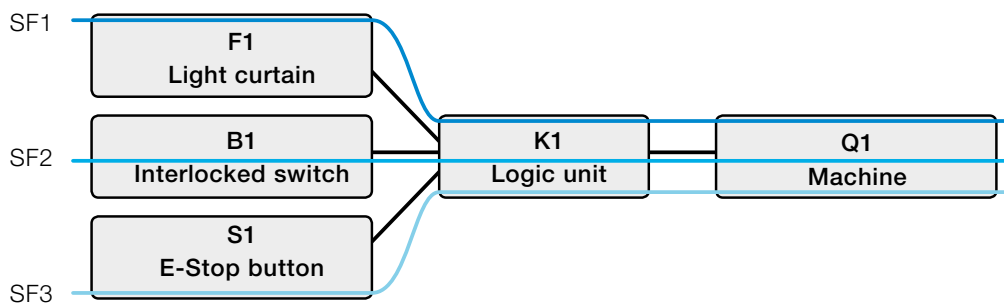

Multiple safety functions for multiple machines in a cell

More commonly, several machines in a single cell/zone are to be protected by multiple safety devices. The following figure illustrates the interconnection schematically for an example. Each of the machines Q1 – Q3 is shut down separately and independently of K1.

If the operator enters the cell, he is exposed in this case to the same type of risk from all three machines. The power to all three machines must be cut when the operator enters the cell through the door interlocked by B1.

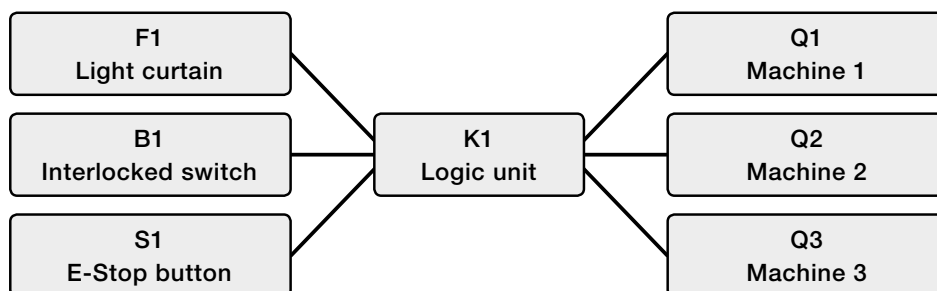

Theoretical approach for multiple machines

The theoretical approach to calculate the safety function is as follows:

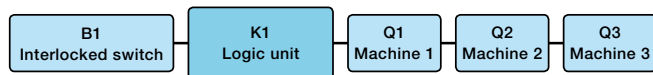

For the full safety function to be performed you require all the components to be working. Note that if B1 or K1 has a dangerous malfunction, the entire safety function is disabled. However, if for example machine Q1 has a dangerous malfunction, and is not shut down, machines Q2 and Q3 will still be shut down. One disadvantage in considering the safety function in this way is that you may have trouble achieving the PL_r required. But if you achieve the PL_r required, you can use the theoretical approach.

Sources:

www.dguv.de/ifa/de/pub/grl/pdf/2009_249.pdf
www.bg-metall.de/praevention/fachausschuesse/infoblatt/deutsch.html
 (No 047, Date 05/2010)

Practical approach for multiple machines

A more practical approach is to divide the safety function into three parts, one for each of the three machines.

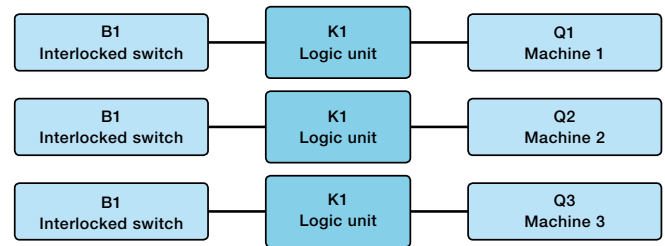

This is an approach that can provide a more accurate way of looking at the safety functions, especially where a different PL_r is required for the safety functions above. If machine Q1 is a robot and machine Q2 is a conveyor which is designed to have negligible risks, the different PL_r required to protect against risks from Q1 and Q2 will also be different. This practical approach is therefore the one recommended. The interpretation is based on information provided by IFA (Institut für Arbeitsschutz der Deutschen Gesetzlichen Unfallversicherung). For more information on this and other issues, see Sources.

Example of safety functions for multiple machines in a cell

For a cell with three machines (one robot, one hydraulic press and one pneumatic machining tool) a risk assessment is made resulting in different PL_r for the individual machines. The robot and the hydraulic press requires $PL_r = e$, while the pneumatic machining tool requires $PL_r = d$.

One of the safety functions is that a non-contact sensor

(Eden) supervised by a safety PLC (Pluto) shall disconnect the energy to all three machines in the hazard zone:

- Eden B1 ($PFH_{D,B1} = 4.5 \cdot 10^{-9}$)
- Pluto K1 ($PFH_{D,K1} = 2 \cdot 10^{-9}$)
- Robot Q1 ($PFH_{D,Q1} = 5.79 \cdot 10^{-8}$)
- Hydraulic press Q2 ($PFH_{D,Q2} = 8 \cdot 10^{-8}$)
- Pneumatic machining tool Q3 ($PFH_{D,Q3} = 2 \cdot 10^{-7}$).

Practical approach

If you use the practical approach the safety functions are as follows:

Robot:

$$PFH_{D,B1} + PFH_{D,K1} + PFH_{D,Q1} = 4.5 \cdot 10^{-9} + 2 \cdot 10^{-9} + 5.79 \cdot 10^{-8} = 6.44 \cdot 10^{-8} \longrightarrow PL e$$

Hydraulic press:

$$PFH_{D,B1} + PFH_{D,K1} + PFH_{D,Q2} = 4.5 \cdot 10^{-9} + 2 \cdot 10^{-9} + 8 \cdot 10^{-8} = 8.65 \cdot 10^{-8} \longrightarrow PL e$$

Pneumatic machining tool:

$$PFH_{D,B1} + PFH_{D,K1} + PFH_{D,Q3} = 4.5 \cdot 10^{-9} + 2 \cdot 10^{-9} + 2 \cdot 10^{-7} = 2.07 \cdot 10^{-7} \longrightarrow PL d$$

This is to be done in a similar way with other safety functions for the cell. For each safety device, you define the machines it affects, and establish the various safety functions according to this.

Theoretical approach

How would it have worked if you had used the theoretical approach? Would the safety function have achieved $PL e$?

All machines:

$$PFH_{D,B1} + PFH_{D,K1} + PFH_{D,Q1} + PFH_{D,Q2} + PFH_{D,Q3} = 4.5 \cdot 10^{-9} + 2 \cdot 10^{-9} + 5.79 \cdot 10^{-8} + 8 \cdot 10^{-8} + 2 \cdot 10^{-7} = 3.44 \cdot 10^{-7} \longrightarrow PL d$$

In this case, the safety function would therefore have not achieved a total $PL e$, which was required for the risks associated with the robot and hydraulic press.

Conclusions

- Use the practical approach.
- Use safety devices/logic units with high reliability (low PFH_D) to make it easy to achieve the PL_r required.
- With Vital or Pluto, it is easier to achieve the PL_r required.

Please note that the examples on these pages are simplified in order to explain the principles. Values of products can also change.

SISTEMA

A tool for determining performance level (PL) and generating technical documentation

1

EN ISO 13849-1 requires calculations. To do this in a manageable way a software tool provides excellent help. ABB Jokab Safety has chosen to use SISTEMA, a software tool developed by BGIA, now called IFA, in Germany. The tool is freeware and can be downloaded from the IFA website, www.dguv.de/ifa. With SISTEMA it is possible to “build” safety functions, verify them and generate the technical documentation required.

To work with SISTEMA in a rational way, we have developed a library of our products for download from our website www.abb.com/jokabsafety. In order to have access to the latest version, visit this page periodically to check for updates and new releases.

To download SISTEMA go to www.dguv.de/ifa/en/prs/software/sistema/index.jsp or search the Internet for “sistema”.

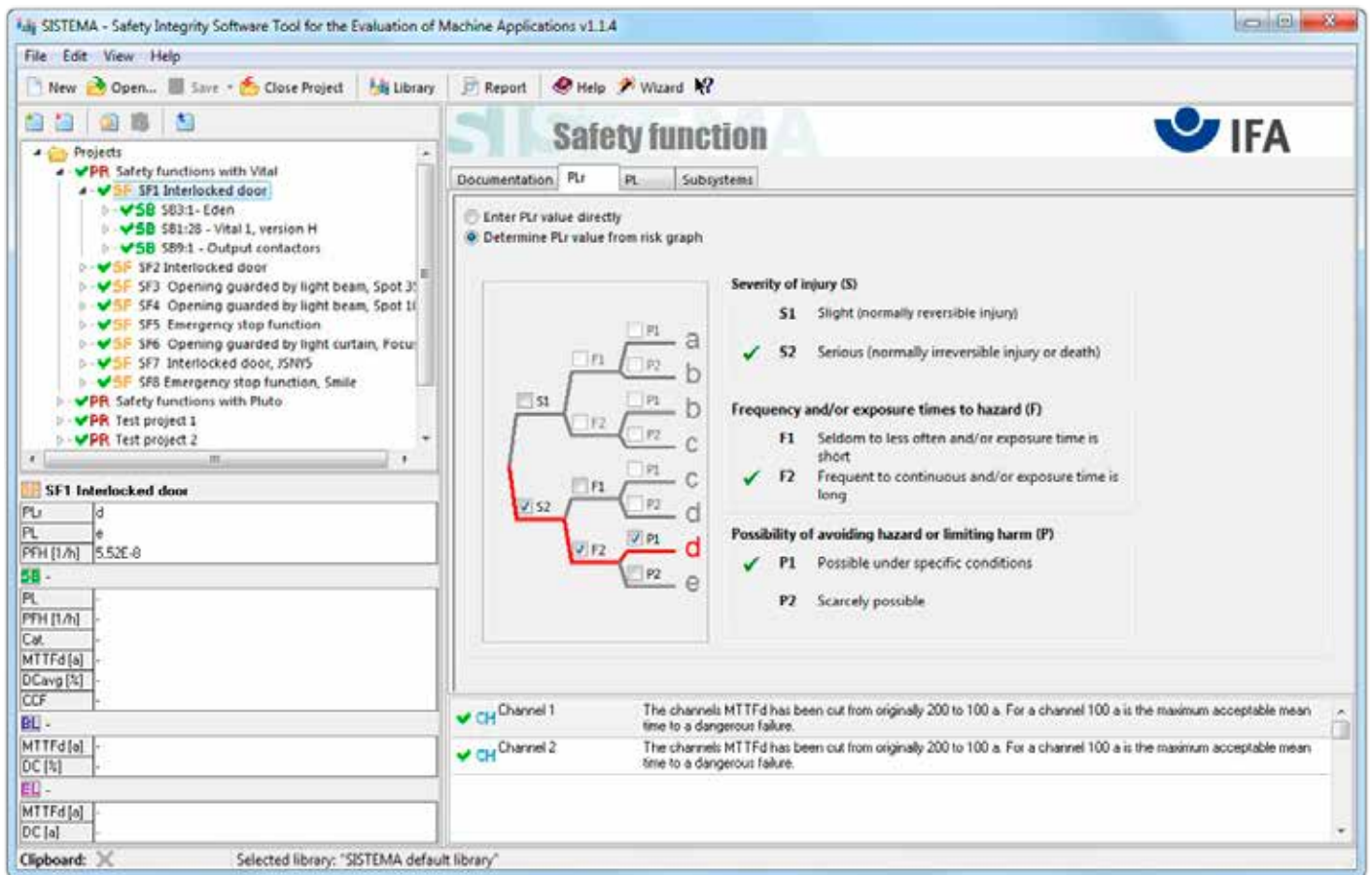

Screenshot from SISTEMA.

Safety relay, Vital or Pluto?

Various benefits in comparison to EN ISO 13849-1

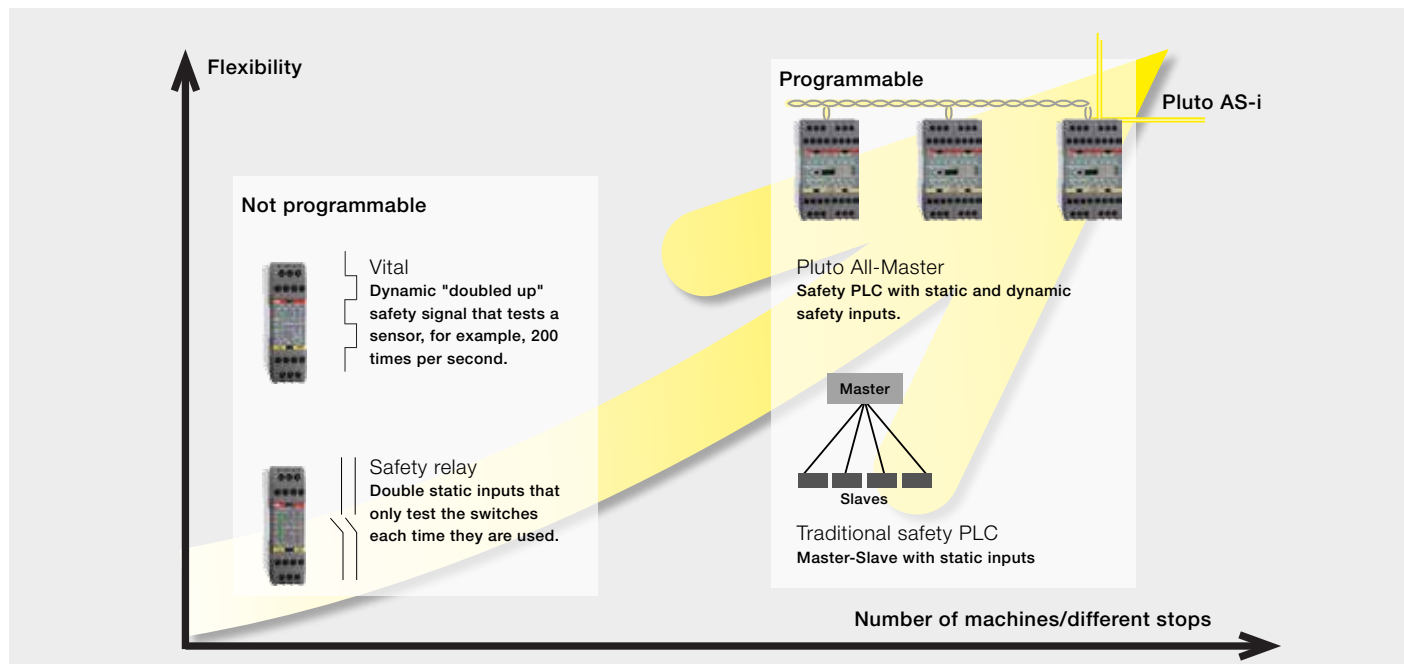

To achieve PL e using a conventional safety relay, such as RT9, you need to use both channels on the input side and only connect a single safety device. Under certain conditions PL d can be achieved by connecting multiple two-channel devices to a safety relay, but this is not a generally accepted method. Vital is a safety controller that allows you to connect

and monitor a variety of safety components in series, and to achieve PL e to EN ISO 13849-1. The Vital module is based on a dynamic single-channel concept and can replace multiple safety relays. A similar solution, although more flexible, is safety PLC Pluto. Pluto, like Vital, is able to make use of dynamic signals to achieve maximum reliability.

Benefits of Vital

- It is possible to connect up to 30 safety components through a channel in line with PL e
- No programming required
- The option of combining various safety components (e.g. emergency stop button and door contact)
- Easy configuration of the circuit
- Electromechanical switches can also be used (with the addition of the Tina adaptation device)

More than 70 000 Vital systems have been successfully installed.

Benefits of Pluto

- Pluto is an all-master-system with communications across a separate safety bus
- Greater flexibility facilitates the design of protection systems
- One software for all systems
- Easy programming for PL e by using function blocks (certified by TÜV)

More than 30 000 Pluto systems have been successfully installed.

Applying EN 62061

1

If one chooses to design a safety function in accordance with EN 62061, the level of reliability is expressed as the Safety Integrity Level, SIL. There are a total of 4 levels, but in the EN 62061 standard SIL 3 is the highest level. SIL also (similar to the Performance Level PL), is expressed as the Probability of Dangerous Failure Per Hour.

Safety Integrity Level, SIL	Probability of dangerous Failure per Hour (PFH _d)
3	$\geq 10^{-8}$ to $< 10^{-7}$
2	$\geq 10^{-7}$ to $< 10^{-6}$
1	$\geq 10^{-6}$ to $< 10^{-5}$

There is a method in EN 62061 for assigning the Safety Integrity Level.

Severity (Se)	Class (Cl)				
	3-4	5-7	8-10	11-13	14-15
4	SIL2	SIL2	SIL2	SIL3	SIL3
3		(OM)	SIL1	SIL2	SIL3
2			(OM)	SIL1	SIL2
1				(OM)	SIL1

Cl=Fr+Pr+Av OM=Other Measures

The seriousness of injury that can occur is defined at one of four levels. Class is the addition of the values of frequency (Fr, stated as a value between 1 and 5, where 5 represents the highest frequency), probability that a dangerous event will occur (Pr, stated as a value between 1 and 5, where 5 represents the highest probability) and the possibility of avoiding or limiting injury (Av, stated as a value of 1, 3 or 5, where 5 represents the least chance of avoiding or limiting an injury).

The safety function that is to be designed must at least fulfil the SIL that has been assigned to it in the analysis. The safety function consists of a number of sub-elements. Example: a door is interlocked by a non-contact sensor which is in turn monitored by a Pluto safety PLC, with outputs that break the power to two supervised contactors. The sensor is sub-element 1, Pluto is sub-element 2 and the two supervised contactors are sub-element 3. If in the analysis it has been established that SIL2 shall be used, every individual sub-element in the safety function must fulfil the SIL2 requirements. The safety function must then in its entirety fulfil the SIL2 requirements.

Definition of protective safety in accordance with EN 62061

"Function of a machine whose failure can result in an immediate increase of the risk(s)"

If the SIL requirements are not fulfilled in any of the sub-elements or by the safety function in its entirety, there must be a re-design.

Finally

This is just a brief introduction to the EN ISO 13849-1 and EN 62061 standards. You are welcome to contact us so that we can prepare suitable training and guide you in how to apply the standards to our products.

A mechanical switch does not give a safe function!

A mechanical switch does not give a safe function!

When it comes to mechanically operated interlocked switches, it has long been accepted a Category 1 switch is adequate for many installations, which is also supported by several standards. However some companies have now re-evaluated this and have instead started to demand two mechanical switches or non-contact switches/sensors, where they previously accepted single mechanical switches. Many reported incidents form the background to this. The requirements for switches to provide safe functioning are that they are mounted correctly and that their positions do not change during their life-cycle, in other words, ideal conditions. In many installations the location of hatches or doors changes over time. This has led to a switch not giving a stopping signal when an interlocked gate has opened. The reasons for this are many, but they can be summarized in mechanical deterioration or physical damage to a door/hatch. In turn this has led to an interlocked switch being affected by higher stress than the switch manufacturer's specifications. To avoid this type of malfunction it is more appropriate to use non-contact switches/sensors because mechanical deterioration does not affect the safety function, i.e. the stop signal is given directly if the position is wrong.

A non-contact switch/sensor does not have a guided function and is designed to fulfill the requirements in another way. The requirements are fulfilled either with dynamic sensors where the safety signal is monitored all the time and a fault directly leads to a stop signal or with a magnetic switch which has two independent contact elements which are monitored every time a gate opens. From the user's perspective the dynamic function is preferable because several sensors can be connected to a single safety module and still achieve PL e. Also the sensor's safety function is monitored without having to open a gate. For a magnetic switch the requirements for PL e are only fulfilled if one switch per monitoring unit is used and if the gate is opened regularly.

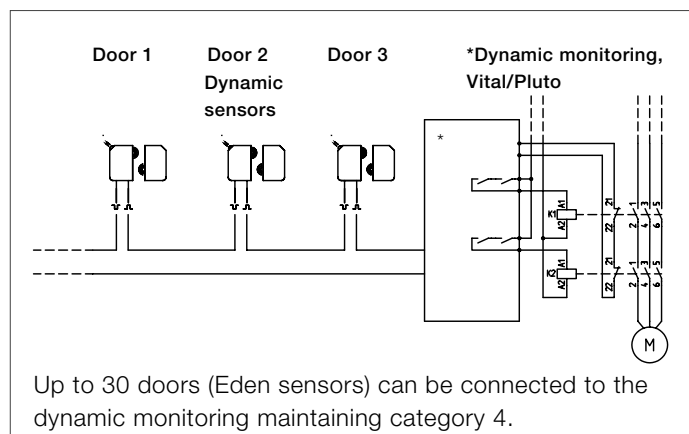

If PL e is to be achieved with electromechanical switches, maximum two switches can be connected to one safety relay. This means that it is only with Eden that several doors can be supervised with one safety module and achieve PL e.

Since the standard EN 954-1 was written, development has progressed and the costs to fulfill category 4 have dropped dramatically. Generally mechanical switches are replaced with non-contact sensors to increase the reliability of production equipment. The same goes for the safety side. With electronic non-contact switches, with a transmitter and a receiver, one avoids the problems of deterioration and excessive stress which harm the sensor. For that kind of sensor dynamic monitoring is required to enable a safe function. This means that its function is constantly being monitored, hundred of times per second. The reaction time for a safe stop will then be the same during a malfunction as during the activation of a stop (e.g. a gate opening). The monitoring frequency will also be astronomical compared to that of mechanical switches and magnetic switches, which are only monitored every time they are used. In the new EN ISO 13849-1, which has replaced 954-1, probability calculations are used together with different category levels to compare different "performance levels". Even when using EN ISO 13849-1 it can be so that one achieves reasonably high theoretical reliability with an electromechanical switch, although this presumes correct installation, proper use and otherwise ideal conditions. A non-contact switch instead provides high levels of both theoretical and practical reliability.

Our conclusion, use dynamic signals!

Our conclusion is that today it is more cost effective, safer and more reliable to work with dynamic signals to achieve category 4 for sensors and monitoring units. In that case it is also possible to fulfill the Machinery Directive, 1.2.7. requirement: "A fault in the control circuit logic, or failure of or damage to the control circuit, must not lead to dangerous situations". Also one does not have to discuss whether the correct safety category has been chosen!

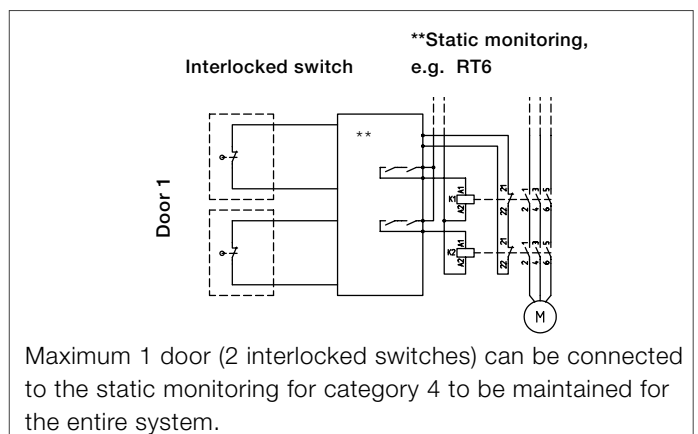

We train you on safety requirements - enhance your knowledge!

What requirements are there today?

For international companies there are many new standards and regulations with which to comply. There have also been changes and revisions of existing standards and directives.

As a business and designer one is obliged to know about and to follow all the regulations. But it can be difficult for each individual company to keep track of all the new regulations and how they should be applied.

Your local ABB Jokab Safety sales office can help you with training and analysis during a build-up phase or as a continuous consulting assignment.



Our course trainers have a extensive experience in machine safety

A distinguishing feature of all the engineers at ABB Jokab Safety is that they work daily with practical applications of standards and regulations. This is true for everything from safety components for individual machines to entire deliveries of safety systems for larger production lines. Within the company there is also a very good knowledge of machine control and production. We are also represented in standardisation groups which decide on European and International standards concerning machine safety. Because ABB Jokab Safety is represented globally, we have the knowledge of safety requirements in different countries.

Training in machine safety

Are you building machines for sale or for your own use? Are you a user of machines? Are you working with automation of production plants or do you make technical evaluations of machines prior to purchase?

Regardless of the purpose, there is a need for knowledge concerning what requirements and regulations exist in respect of machine safety, and how they should be applied.

We offer company-adapted training in the following fields:

- Product liability and its consequences
- CE-labelling
- The Machine Directive and how to apply it
- Choice of certification procedure with examination of the parts which are required in order to be able to CE-label a machine
- Harmonised standards and the applications of these, e.g.
 - EN ISO 13849-1/-2
 - EN ISO 12100
 - EN 60204-1
 - EN ISO 13850
 - EN ISO 13857
 - EN ISO 13855 (previously EN 999)
- Machine safety analysis; method and cases
- Choice of safety measures/safety devices
- Requirements for manufacturer's technical documentation
- Requirements for manuals
- Requirements for "old machines"
- Specific interpretation cases, e.g. re-construction of machines
- Changes in the Machine Directive

Company-adapted training in machine safety

Contact your local sales office with questions and your current training needs. Together with you, we will customize the training to your specific company requirements.

Training in risk analysis

We regularly have training courses in our offices. One of these covers risk analysis and how to choose production adapted measures.

A course in risk analysis contains the following:

- Risk analysis - from theory to practice
- What durability towards errors shall the safety system have?
- Standard EN ISO 13849-1/-2
- Safety distances for fencing systems and safety components - how do you choose?
- Cases, practice and briefing of risk analysis and choice of actions

Product training

Our unique Pluto Safety PLC gives new and great possibilities to build-up a cost effective and flexible safety system. With this also comes the demands of higher knowledge. For you as a customer to be able to quickly get started using Pluto in the most effective way and to learn about its possibilities, we regularly offer trainings at our local sales offices. In the training course cost is included a Pluto, software for Pluto and full documentation. We also offer training on the other ABB Jokab Safety products such as the Vital solution, safety relays and light beams/curtains.

Training - Pluto and other ABB Jokab Safety products

Contact your local sales office with questions and your current training needs. Together with you, we will customize the training to your specific company requirements.



Consulting

Do you need assistance in CE-marking a machine? Do you want a third party to carry out a risk analysis on a machine line? Do you have the need of a partner to examine how various regulations effect the safety of your machines?

We can offer assistance and support in both short and longer assignments. Here are a few examples of what we can offer you:

- **Risk analysis** with proposal of measures. We do this together with the customer and it is often done as a pilot-project so that the company afterwards themselves can carry out analysis.
- Guide the customer business through a **CE-marking** of machine/plant.
- Write/review **technical documentation/manuals**
- **Interpret** standards and regulations
- **Stopping time measurement** - We can measure the stopping time on your machines with our Stopping time and motion analyser tool. Knowledge of the stopping time is a prerequisite to be able to determine the correct safety distance. EN ISO 13855 (previously EN 999) gives the requirements.
- **Programming of Pluto Safety-PLC.**



Stopping time measurement is required in order to be able to determine the correct safety distance.

Consulting - Contact us

Come to us with your needs and we will plan with you a suitable project programme. You can also contact us with short questions which we can solve directly over the phone or via e-mail.

Pluto Safety PLC

With dynamic safety concept

Why should you have Pluto safety PLC?	2/3
Connection examples for Pluto	2/5

Pluto safety PLC

Pluto	2/7
Function Blocks for Analogue inputs Pluto D20 and D45	2/9
Counter inputs	2/10
Input connection	2/11
Output connector expansion	2/12
I/O overview	2/12
Technical data	2/15
Application examples	2/17

Gateway

Gate P2 - Profibus DP	2/23
Gate D2 - DeviceNet	2/25
Gate C2 - CANOpen	2/27
Gate E2 - Profinet, Ethernet/IP, Modbus TCP	2/29

Safe Encoder

Safe Encoder	2/31
--------------	------

IDFIX

IDFIX	2/35
-------	------

Why should you have Pluto safety PLC?

– for simplifying the design of and changes to safety systems!

Pluto is an "All-Master" safety PLC concept, that simplifies the design of safety systems and achieves the highest safety level PL e according to EN ISO 13849-1 and SIL 3 according to EN 62061 and EN 61508. The key difference between Pluto and conventional safety PLCs is that there is no "Master-Slave" relationship between the control units connected to the safety bus. Each Pluto is a "Master" unit and can see the other Plutos' inputs and outputs, and can thereby make decisions about its own safety environment.

This concept enables simple communication, programming and changes to the safety system. With the use of a "Gateway" device, a Pluto can communicate with other bus systems and thereby form part of a larger network. Gateway units are available for several different bus systems, such as Profibus, CanOpen, DeviceNet, Profinet, Ethernet/IP and Modbus TCP. With a Pluto AS-i, both safety slaves and standard slaves can be handled.

Pluto offers an economic solution for both single machines and for major machine systems.

Our solution with All-Master

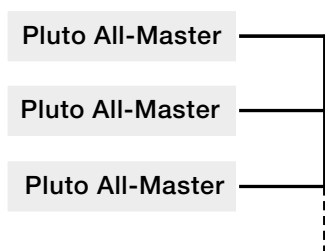

Traditional safety PLC

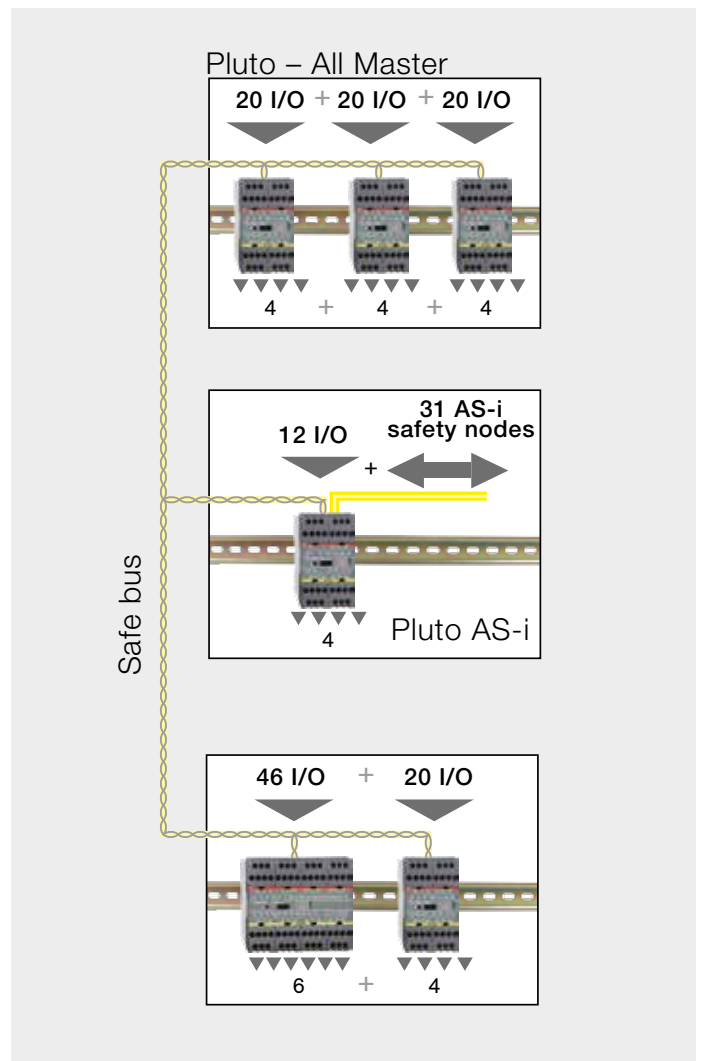
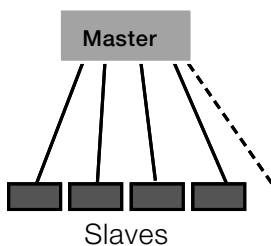

- to supervise safety devices!

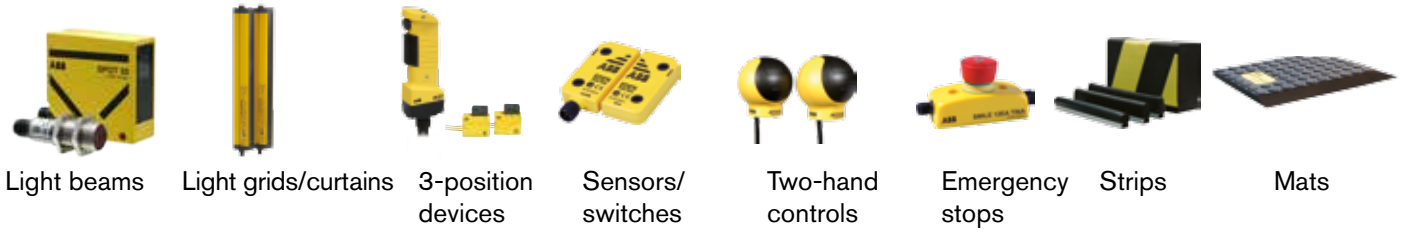

Most safety devices on the market can be connected directly to Pluto units. By using dynamic signals with sensors from ABB Jokab Safety only one input is needed to achieve the highest level of safety, compared to two inputs for other manufacturers' PLCs. It is also possible to connect up to 10 sensors in series to a single input on Pluto and still achieve

the highest level of safety. For example non-contact Eden sensors, Spot light beams and Tina emergency stop buttons can all be connected in series to a single Pluto input. Even mechanical switches can be connected to the "dynamic" safety circuit using ABB Jokab Safety's various Tina adapters. Pluto also has IO connections that can be used as both inputs and outputs.

- to save on inputs!

Dynamic signals
- 1-10 doors with one Eden per door
PL e

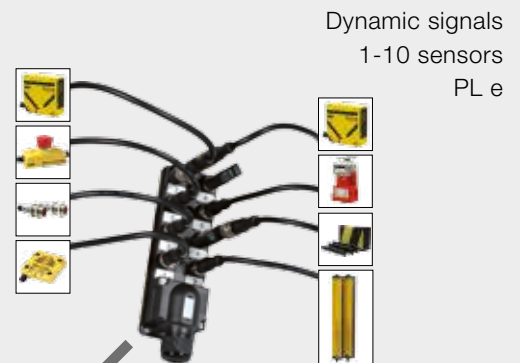
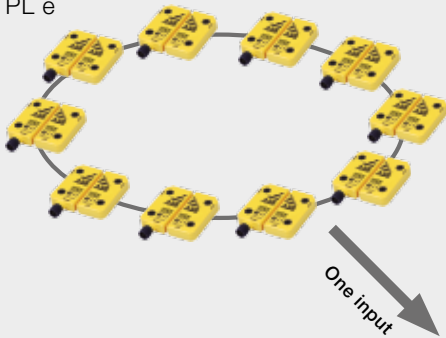

Pluto has inputs for static and dynamic sensors. Several sensors can be connected to one dynamic input in accordance with PL e.

IO connections
Pluto has IO connections that can be used in three ways:
- input
- output
- both input and output at the same time (e.g. for a reset button with lamp indication)

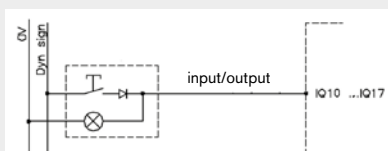

Static inputs (mechanical switches)
2 for each door = PL e



Connection examples for Pluto with safety bus

1. Gateway – For two-way safe bus communication between Pluto and other control systems.

2. Absolute encoder – 8 single turn or multi turn absolute encoders can be connected directly to the safety bus.

2

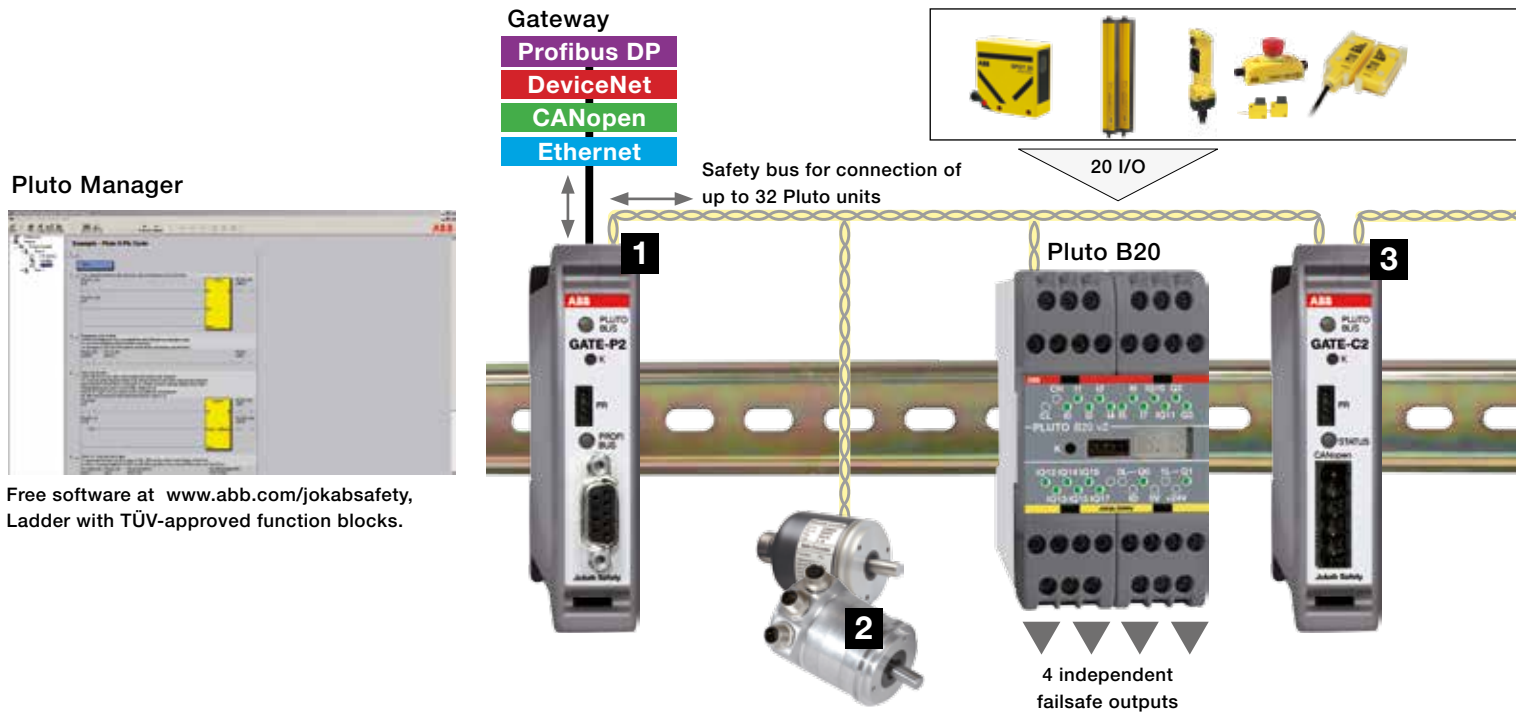

Connection examples for Pluto without a safety bus

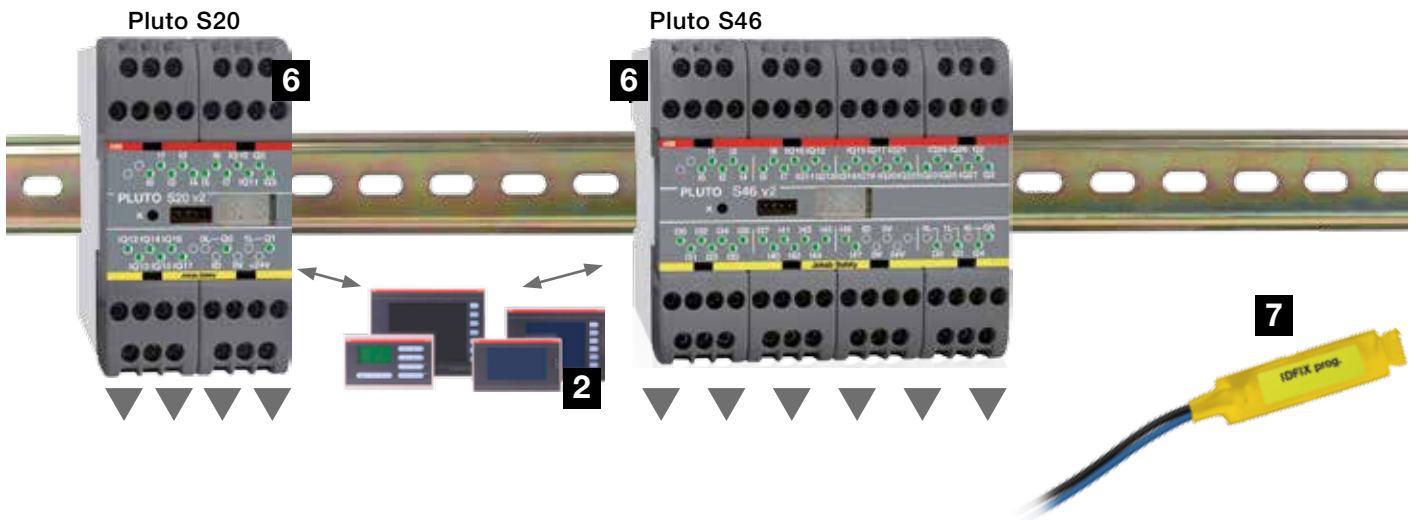

6. Stand alone Pluto
 Same functionality as other Plutos, but without safety bus connections.

7. IDFIX – Identifies Pluto
 If IDFIX PROG is used for single-Pluto, there is the option of copying a PLC program via the identification circuit over to Pluto without having to connect a computer.

- 3. Pluto bridge** – With a Gateway it is possible to:
- increase the safety bus length
 - use different bus speeds for each section
 - filter information from one section to reduce the load on the safety bus.

4. HMI – An HMI operator panel can communicate with Pluto in both directions. Connection can be made direct to the front of the Pluto.

5. Pluto AS-i – Can either be AS-i master on the AS-i bus or work together with an AS-i master as a monitor. It includes AS-i nodes, analogue and digital outputs, as well as safety outputs. Also available as Pluto B42 AS-i for more I/O. For more information see the AS-i safety chapter.

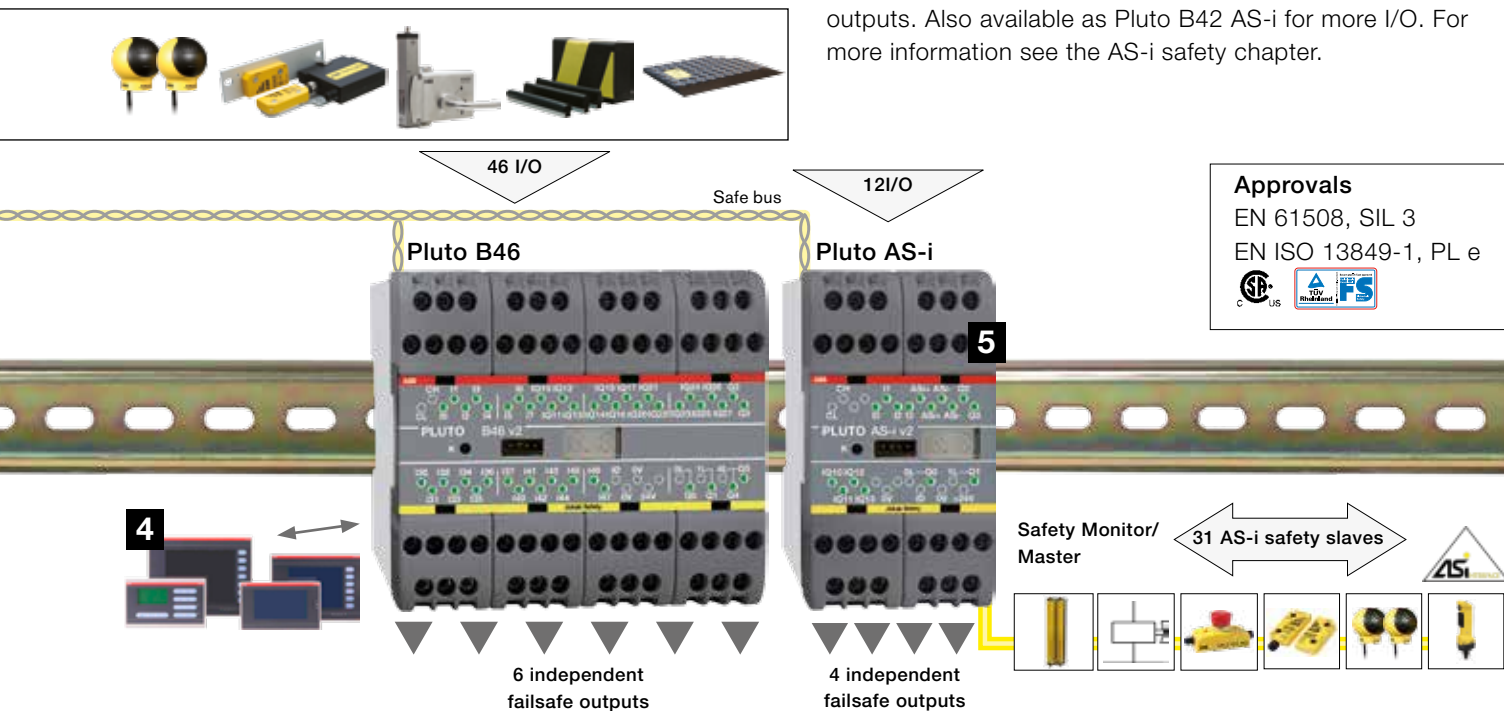

Overview Pluto Safety-PLC

Model	S20	S46	A20	B22	D20	D45	B20	B46	AS-i	B42 AS-i
Number of I/O	20	46	20	22	20	45	20	46	12	42
Failsafe inputs	8	24	8	14	8	24	8	24	4	20
Failsafe inputs or non-failsafe outputs	8	16						16		
Analogue inputs 0-10V/4-20mA	-	-	8	8	8	15	8	-	4	16
Counter inputs	-	-	-	-	-	4*	-	-	-	-
Analogue inputs (0-27V)	1	3	1	1	1	3	1	3	4	3
Failsafe relay outputs	2	4	2	-	2	4	2	4	2	4
Failsafe transistor outputs	2	2	2	-	2	2	2	2	2	2
Pluto bus	-	-	●	●	●	●	●	●	●	●
Pluto AS-i bus	-	-	-	-	-	-	-	-	●	●
Current monitoring	-	-	2	-	-	-	-	-	-	-
Dimensions (b x h x d) mm	45 x 84 x 118	90 x 84 x 118	45 x 84 x 118	45 x 84 x 118	45 x 84 x 118	90 x 84 x 118	45 x 84 x 118	90 x 84 x 118	45 x 84 x 118	90 x 84 x 118
Supply voltage	24VDC	24VDC	24VDC	24VDC	24VDC	24VDC	24VDC	24VDC	24VDC	24VDC

*4 of the analogue inputs can be configured as counter inputs. The total number of analogue inputs + counter inputs = 8.

safety function. This means that the current must be read and evaluated both when the output is enabled and disabled.

Pluto for the AS-i system

Pluto AS-i can either be AS-i master on the AS-i bus or work together with an AS-i master as a monitor. It includes AS-i nodes, analogue and digital outputs, as well as safety outputs. Also available as Pluto B42 AS-i for more I/O. For more information see the AS-i safety chapter.

Pluto D20 and D45 - with analogue inputs

Pluto D20 is equipped with 4, and Pluto D45 with 8, safe 4-20mA/0-10V analogue inputs. These can be configured as either "ordinary" failsafe inputs, as analogue inputs 0-10V or as analogue inputs 4-20mA. For an application to reach SIL 3/PL e it is required that two sensors in parallel with one input each are being used.

Counter inputs Pluto D45

For Pluto D45 four of the analogue inputs can be configured as counter inputs (pulse counting) which work for frequencies up to 14000 Hz. As counter inputs IA0 – IA3 can be used in two ways, Up counting or Up/Down counting.

Pluto B22 - expansion module with increased number of inputs

Pluto B22 is an expansion module without safety outputs. It is equipped with 14 safe inputs and 8 safe inputs or non-safe outputs.

Technical info - Dynamic signal

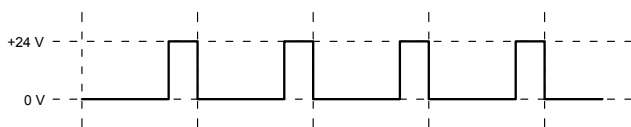

A dynamic signal makes it possible to achieve the highest level of safety with only one conductor. By transmitting a square wave and then evaluating the signal when it comes back to the controller you achieve the redundancy required. The signal is inverted once at each safety sensor (if the protection is OK) which makes it possible to detect short circuits across a sensor. When the signal switches between high (+24 V) and low (0V) it can be evaluated and tested about 200 times per second.

Pluto can generate three unique dynamic signals; A pulse, B pulse or C pulse. Short circuits between two different dynamic signals are detected whenever the signal that is created is different from the expected signal in Pluto. The kind of signal Pluto expects at the input terminal is determined in Pluto Manager (A, B or C pulse and if the signal should be inverted or not).

Technical info - Static signal

Static signals (+24 V or 0 V) can be connected to all inputs on Pluto. The kind of signal Pluto expects at the input terminal is determined in Pluto Manager. To achieve a two-channel structure according to EN ISO 13849-1 you need two inputs.

Technical info - OSSD-signal

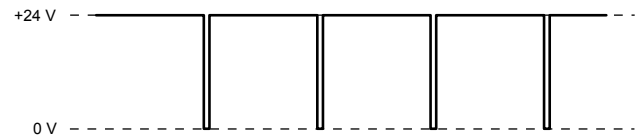

There are safety products with internal monitoring of dual OSSD signals (the device detects its own faults rather than Pluto doing this). From these devices, at least one of the two signals is connected to an I-input in Pluto, i.e. both signals must not be connected to the IQ-terminals. The terminal blocks are then configured in Pluto Manager to expect static inputs (OSSD signals are filtered internally in Pluto).

IQ – individual failsafe inputs and non-failsafe outputs

The IQ terminals can be used either as individual failsafe input or non-failsafe output (e.g. for indicator light or status signal). The terminal blocks can also be used as both input and output simultaneously, which is useful for example for push buttons (input) with indicator light (output). This function is designed primarily for reset buttons to reduce the number of used terminal blocks on the controller.

Technical info - I - individual failsafe inputs

All inputs are individually failsafe as each input is connected separately to both processors in Pluto. In order to maintain the redundancy required for two-channel structure and the highest level of safety, the dynamic signal must be used. When using static signals, two inputs must be used to achieve two-channel structure. The expected signal to the terminals blocks is determined in Pluto Manager (static or dynamic signal).

Technical info - Q - individual failsafe outputs

All Q outputs are individually safe and are independently programmable. There are both relay outputs and transistor outputs.

Technical info - Transistor outputs (-24 VDC)

The transistor outputs are just like the relay outputs, that is individually safe and independently programmable. However, the transistor outputs are different from the relay outputs as the internal connection provides the nominal input voltage -24 VDC, which is primarily intended for controlling electromechanical components such as contactors and valves. As -24 VDC is a unique signal in the majority of electrical cabinets and the fact that the output is monitored by Pluto, short circuits with other potentials can be detected right away.

Technical info - Pluto-bus

The Pluto-bus is a CAN-bus with its own safety protocol. The bus cable can be up to 600 m long at the minimum bus speed, and up to 150 m at 400 kb/s. The bus can be both extended and connected to other types of buses through gateways.

Function Blocks for Analogue inputs Pluto D20 and D45

Configuration in Pluto Manager

The inputs can be configured under “I/O Options” in Pluto Manager. As analogue inputs they can be configured either as 0-10V inputs, or as 4-20mA inputs. For Pluto D45 they can also be configured as Counter inputs.

2

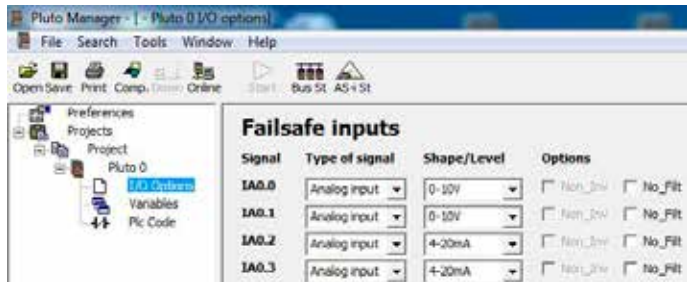

IA0.0 and IA0.1 are configured as Analogue input 0-10V, and IA0.2 and IA0.3 are configured as Analogue input 4-20mA.

ReadVoltage and ReadCurrent function blocks

For analogue input 0-10V the function block “ReadVoltage” is needed, and for analogue input 4-20mA the function block “ReadCurrent” is needed. There are also 32-bit versions of these function blocks (“ReadVoltage_32” and “ReadCurrent_32”) for use with Double Registers. As output from the blocks there is one output with the absolute value in V or mA, and one output which can be scaled as desired. The picture and table below shows the “ReadCurrent” function block only, but “ReadVoltage” works in the same way.

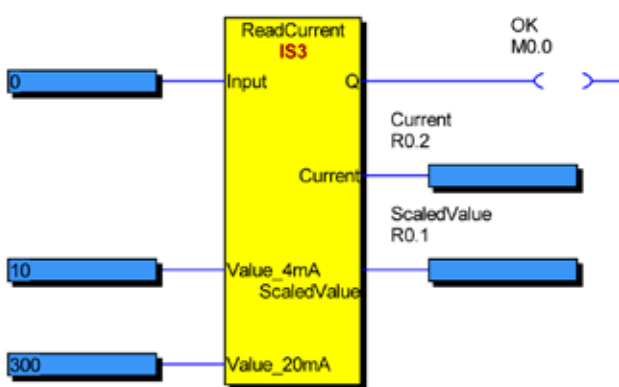

ReadCurrent function block. Description of inputs and outputs:

inp	Input connected to the block.
Value 4mA	Input value for scaling. At 4mA the output “Scaled value” will show this value.
Value 20mA	Input value for scaling. At 20mA the output “Scaled value” will show this value.
Q	OK output. Value is within range.
Current	Output with calibrated absolute value in μ A.
Scaled Value	Output with scaled value.

Counter inputs Pluto D45

For Pluto D45 the inputs IA0 – IA3 can be configured as counter inputs (pulse counting). As counter inputs IA0 – IA3 can be used in two ways, Up counting or Up/Down counting.



Configuration of counter input

Up count

When the input is configured for Up count Pluto counts the pulses on the input. Via a function block the user gets the pulse rate which for example can represent a speed. The sensor can be anything, like an inductive sensor, photocell or incremental encoder (HTL, 24V).

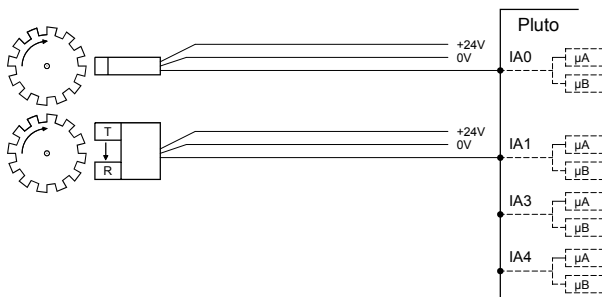

Example of speed monitoring. The sensors can for example be proximity switches or photocells. Any of the inputs IA0..IA3 can be used.

Up/Down count

With the function Up/Down count it is possible to detect the direction of the movement. A pair of inputs, IA0/IA1 and/or IA2/IA3 can be configured as Up/Down counters. In order to make up/down counting it requires that the sensors can produce A/B-pulses. A/B-pulses are two square wave signals that are 90° phase shifted to each other. The sensor is typically an incremental encoder with HTL (24V) interface.

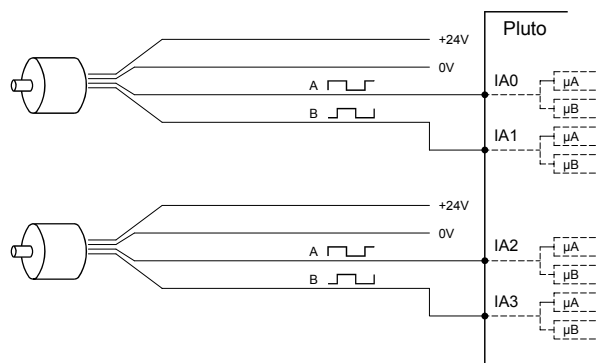

Example of speed monitoring with incremental encoders leaving A and B pulses to two inputs, IA0-IA1 or IA2-IA3. The direction is then possible to measure.

Sensor types

The upper frequency limit is dependent on the type of sensor. For incremental encoders with HTL output (“push – pull”) the counter inputs work for frequencies up to 14 kHz.

For photocells, proximity switches, inductive sensors etc. which normally do not have a “push – pull” output the maximum frequency might typically be 1 – 4 kHz, but the limit is also dependent on the output resistance, the cable length etc.

Function blocks for speed monitoring

For inputs configured as Up count the function block “HS_SpeedCount_Up” shall be used.

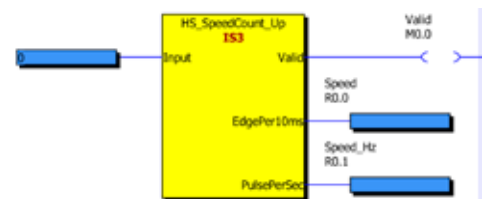

For inputs configured as Up/Down count the function block “HS_SpeedCount_Dir” shall be used.

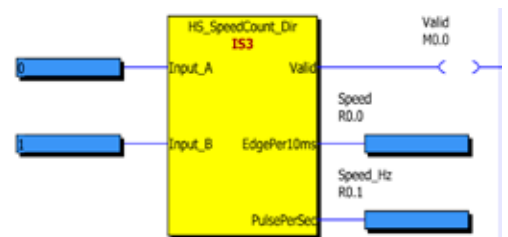

The function block “SpeedMon1” is intended to be used for redundant speed monitoring, but has also functions for stand still monitoring and safe low speed. It has two inputs for speed values. These input registers can take their values from different sources such as the function blocks for incremental encoders, absolute encoders, analogue inputs etc. The input “Speed” is a primary input for a speed value and “Comp-Speed” is a secondary channel for monitoring the correctness of the primary speed value.

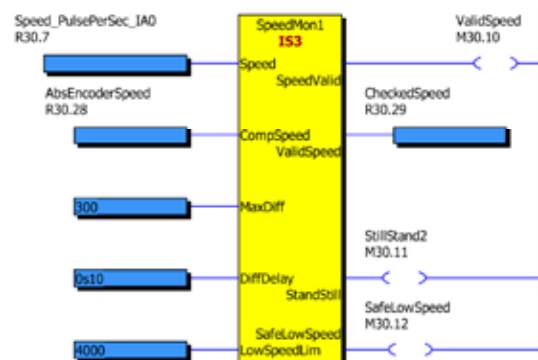

Input connection

The system offers solutions for both single and two-channel safety devices. In order to monitor wiring short-circuits it is possible to use up to three different dynamic signals and static voltage (+24 V) to supply the inputs. The inputs are then programmed to only accept one of the signal types.

2

In a two-channel system both channels will be measured, using two different signals. The system will thereby be able to detect a short-circuit between the channels.

In a single channel system the dynamic signal is modified at each sensor. A short-circuit between the input and the output of the sensor will be detected at the Pluto input. PL e according to EN ISO 13849-1 can thus be achieved by using only one channel and one input.

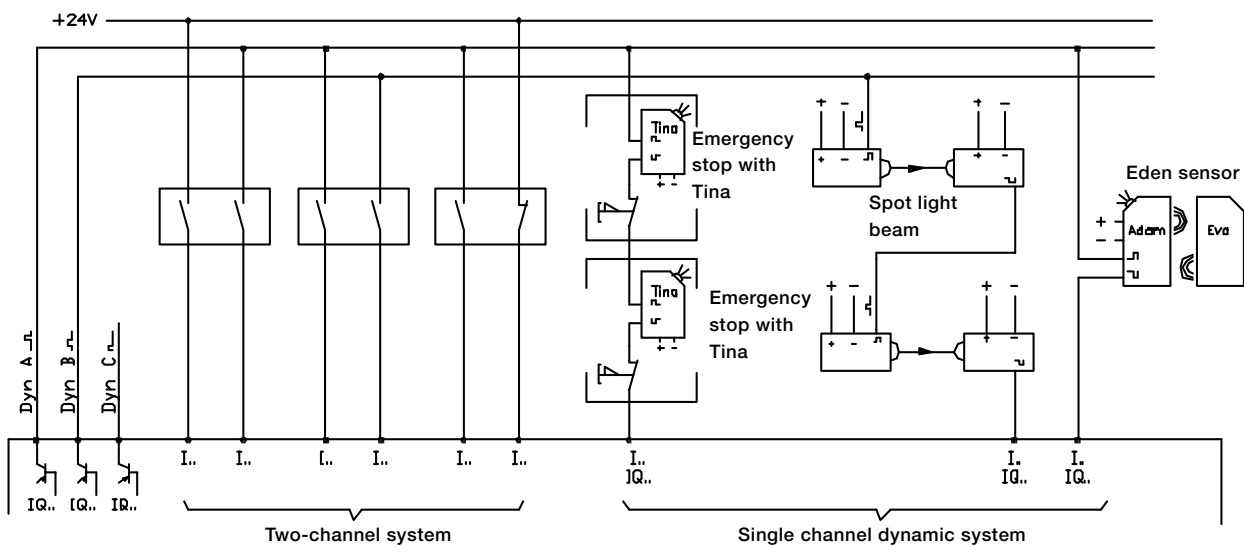

Input connection alternative in accordance with PL e EN ISO 13849-1.

Reset button that uses the combined input and output facility

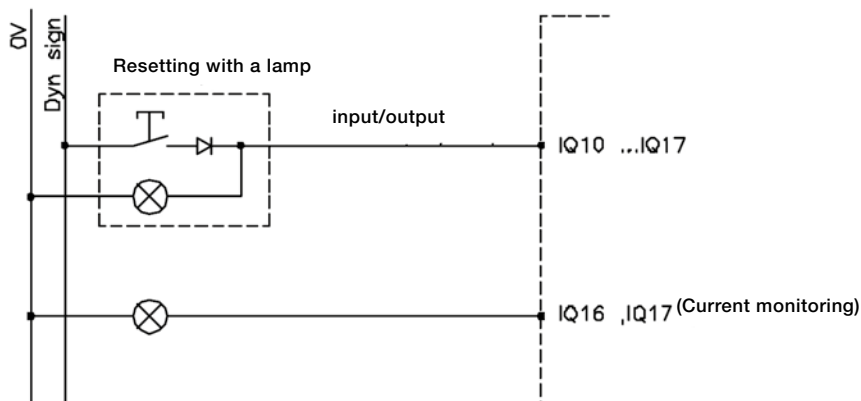

Both a lamp and a pushbutton can be connected to the same terminal. This function is for resetting safety devices and to reduce the number of I/Os used.

Output connector expansion

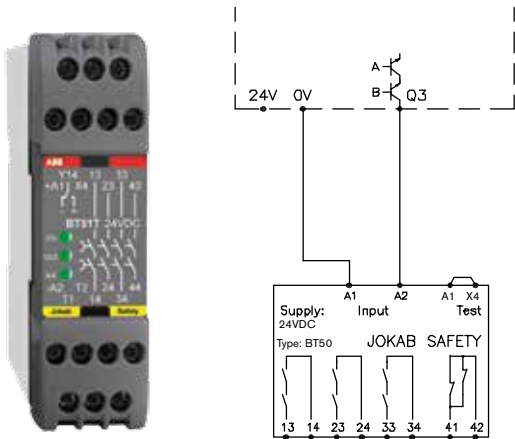

Using an expansion relay, such as BT50, the number of safe outputs in Pluto can be expanded. The connection shall be made as shown in the figure. Several expansion relays can be connected to a single Pluto safety output while retaining the safety level.

I/O Overview

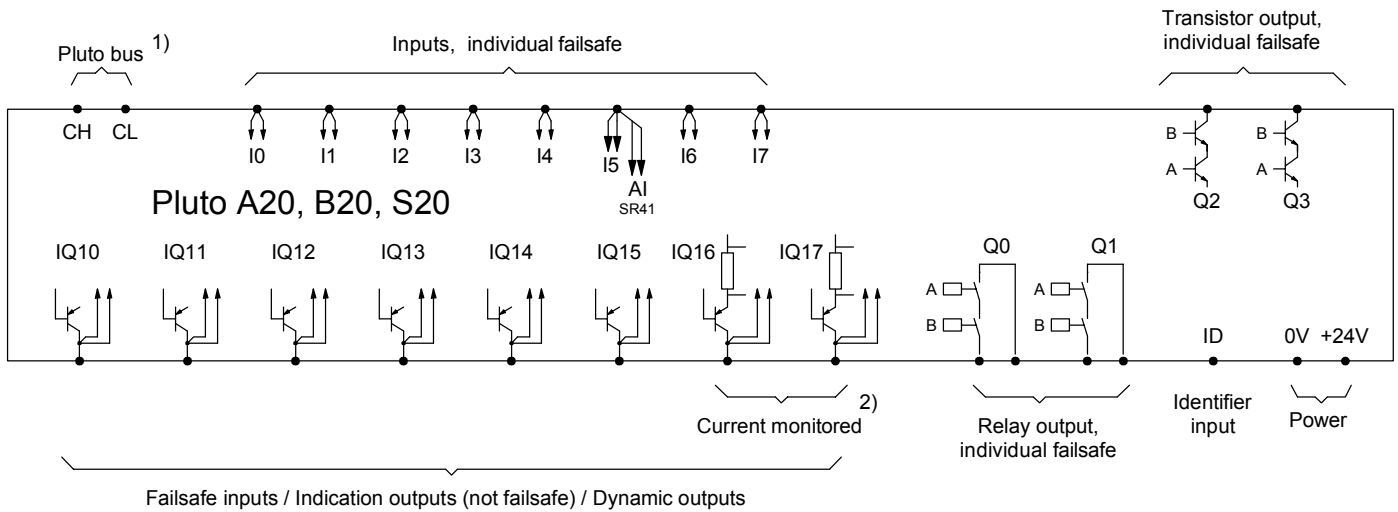

1) Not S-models, S20,...

2) Current monitored only on A20

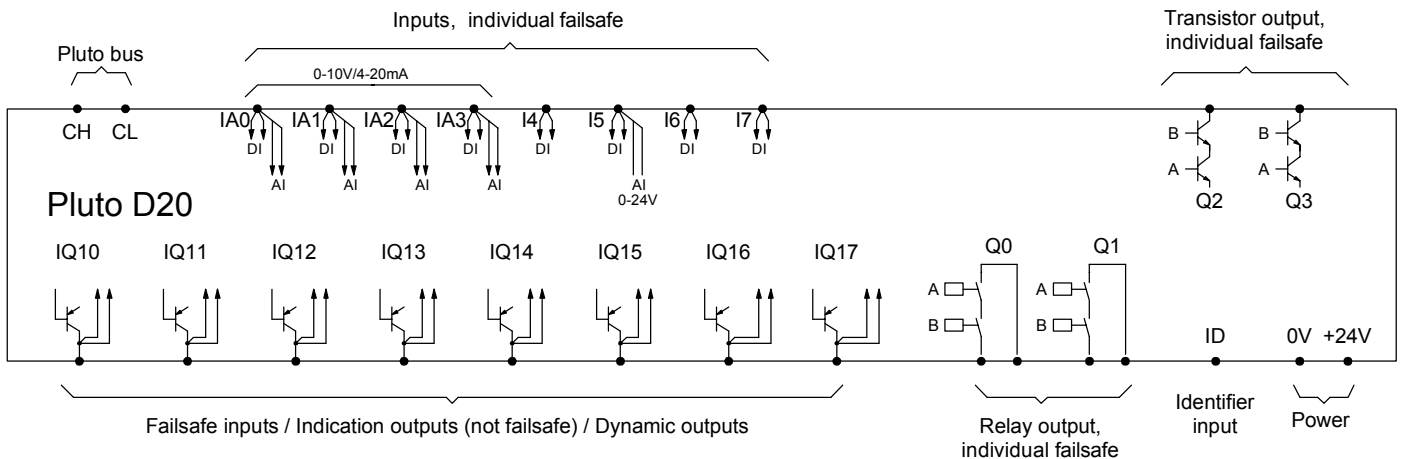

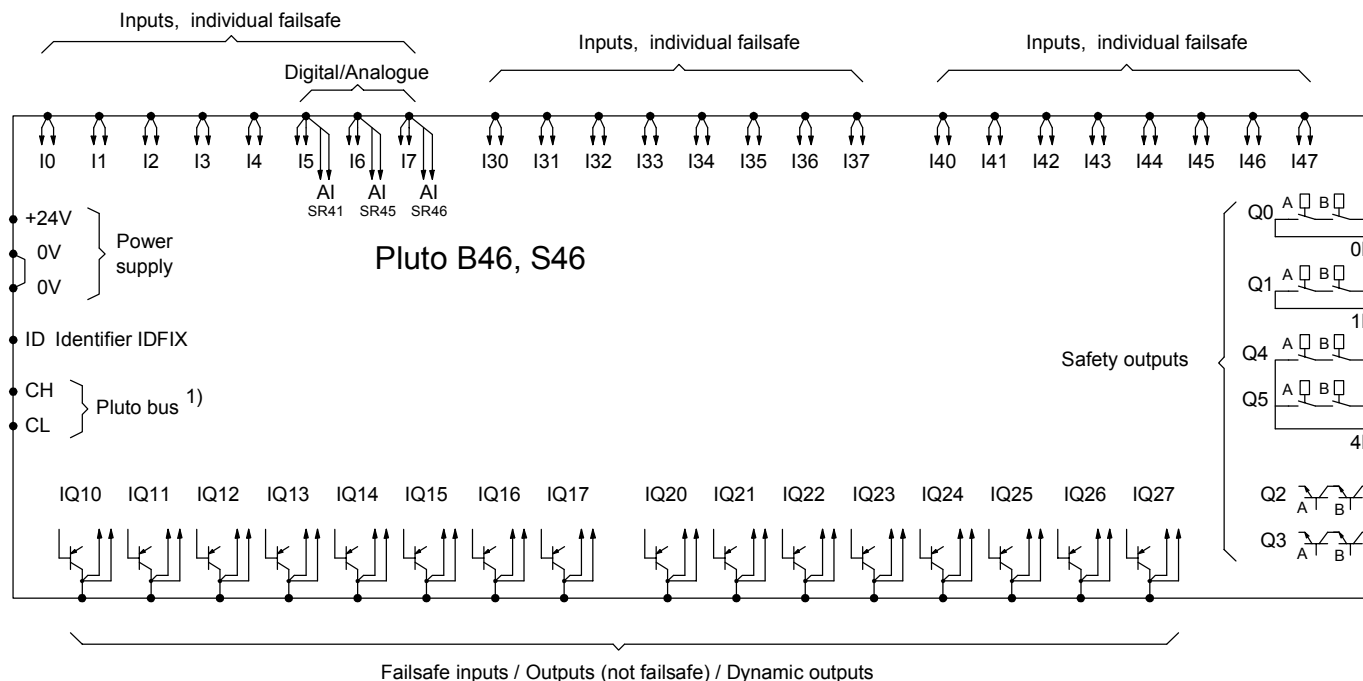
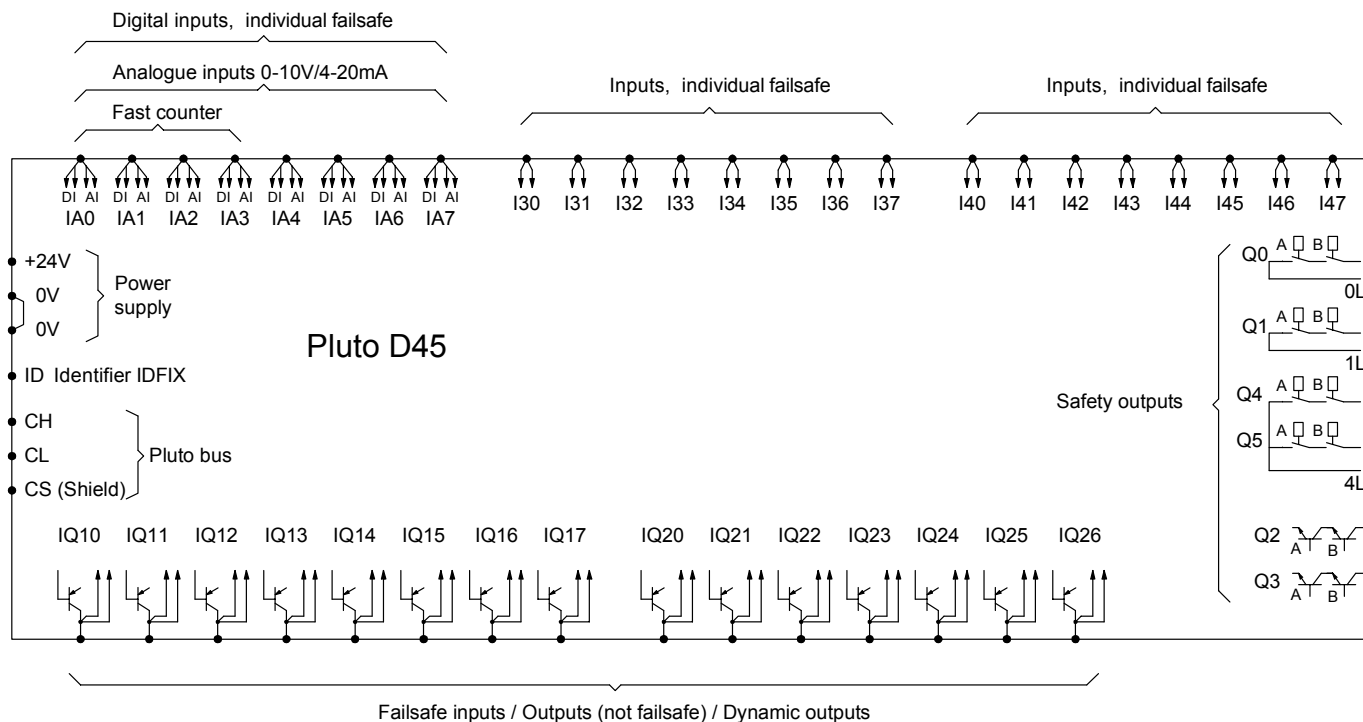
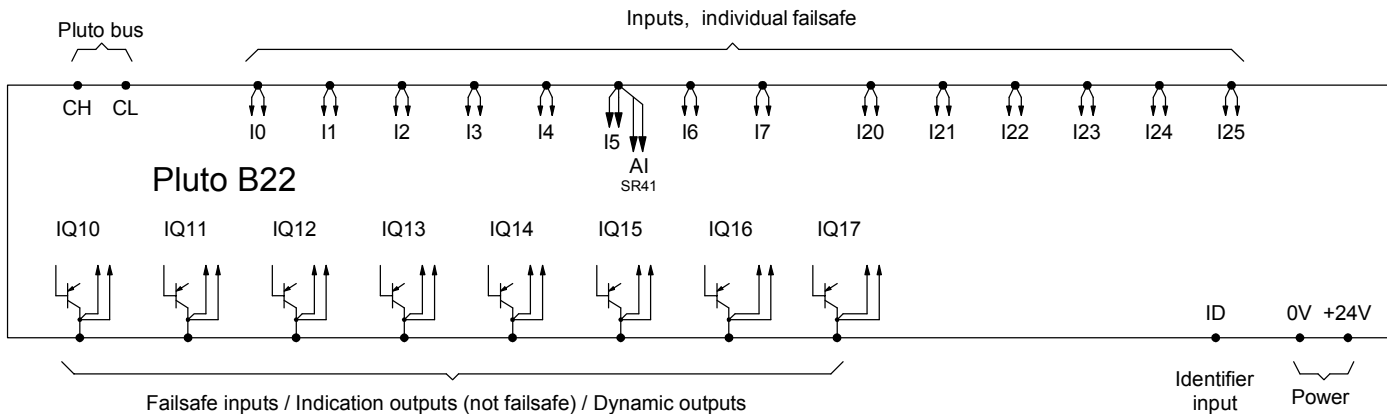

1) Not S46

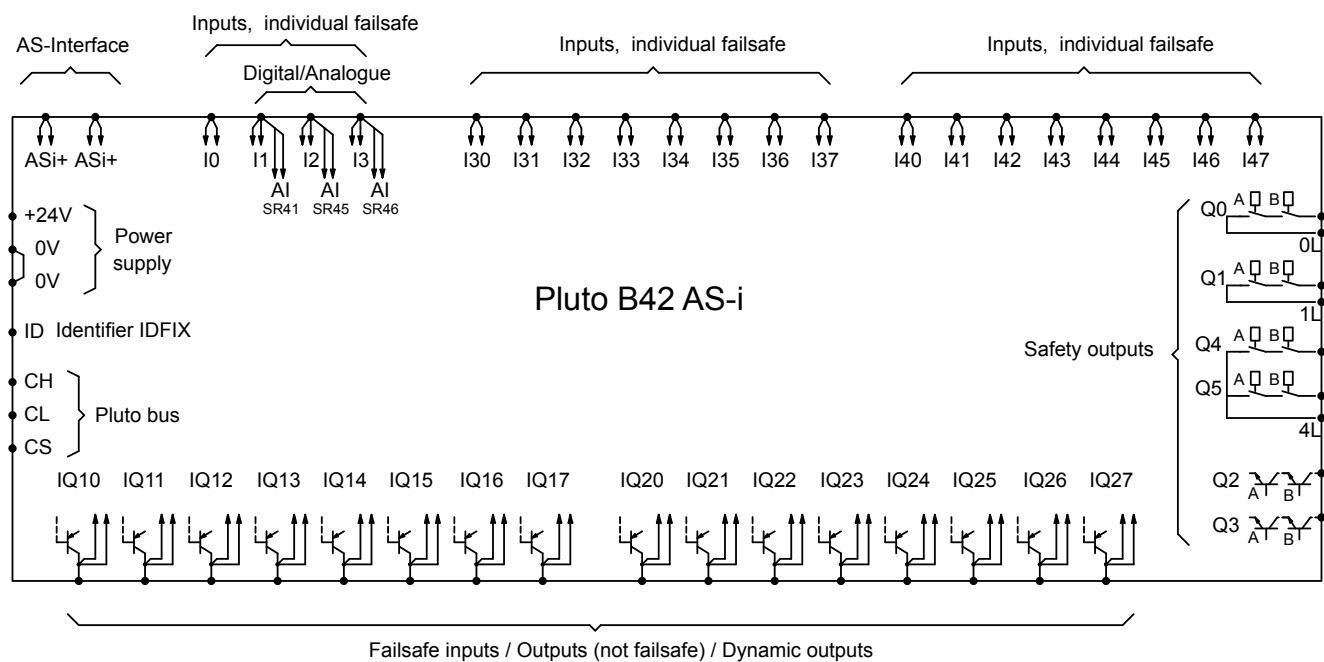
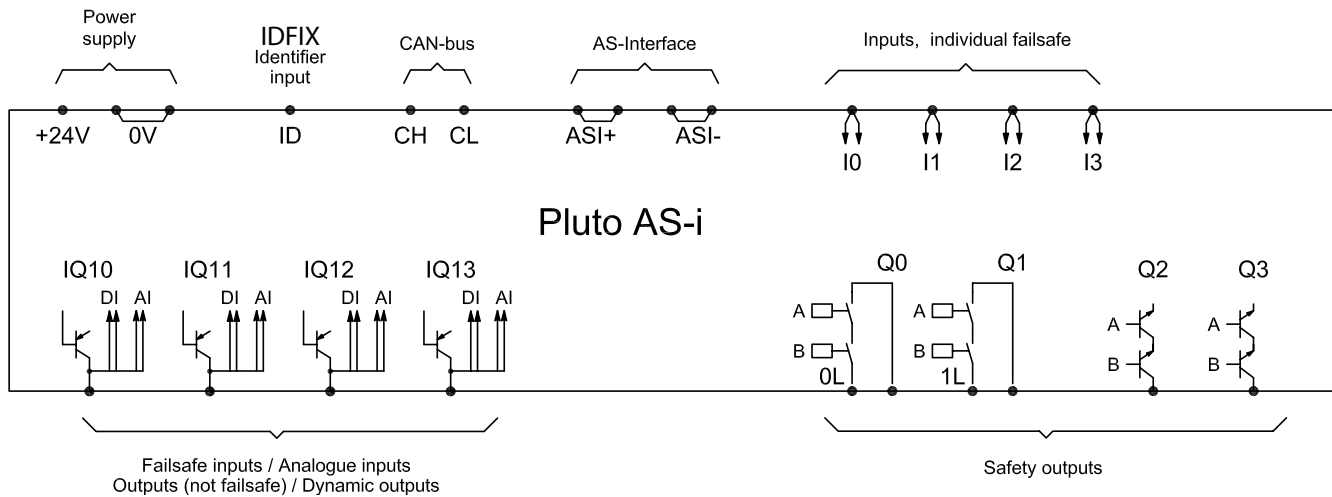

- ID: Connection for identifier, which has a unique ID number that can be read by the system.
- I.. Safety inputs (24 VDC) that are individually failsafe. This means that the highest level of safety can be achieved with only one input if ABB Jokab Safety dynamic safety components are used. Otherwise two inputs are required for each safety function.
- IQ.. I/O that can be used for safety inputs or signal outputs, e.g. to indicate or control functions that are not safety-related. For IQ.. as safety inputs, refer to I..
- Q0, Q1: Failsafe relay outputs that are individually failsafe and individually programmable.
- Q2, Q3: Failsafe transistor outputs (-24 VDC) that are individually failsafe and individually programmable. Intended for electro-mechanical components such as contactors and valves.
- Q4, Q5 Failsafe relay outputs with common potential that are individually failsafe and individually programmable.

Technical data - type-specific

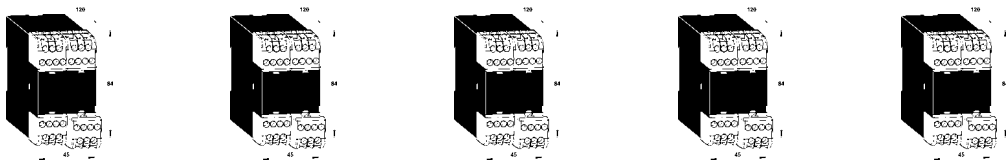

	Pluto A20	Pluto B20	Pluto B22	D20	S20
	20 I/O	20 I/O	22 I/O	20 I/O	20 I/O
	Current monitoring			Analogue inputs	Without safety bus
Article number	2TLA020070R4500	2TLA020070R4600	2TLA020070R4800	2TLA020070R6400	2TLA020070R4700
Failsafe inputs	8 (I0..I7)	8 (I0..I7)	14 (I0..I7, I20..I25)	8 (I0..I7)	8 (I0..I7)
Failsafe inputs or non-failsafe outputs	8 (IQ10..IQ17)	8 (IQ10..IQ17)	8 (IQ10..IQ17)	8 (IQ10..IQ17)	8 (IQ10..IQ17)
	Max total load 2.5 A	Max total load 2.5 A	Max total load 2.5 A	Max total load 2.5 A	Max total load 2.5 A
Analogue inputs (0-10V/4-20 mA)	-	-	-	4	-
Counter inputs	-	-	-	-	-
Analogue inputs (0-27V)	1 (I5)	1 (I5)	1 (I5)	1 (I5)	1 (I5)
Failsafe relay outputs	2 (Q0..Q1)	2 (Q0..Q1)	-	2 (Q0..Q1)	2 (Q0..Q1)
Failsafe transistor outputs	2 (Q2..Q3)	2 (Q2..Q3)	-	2 (Q2..Q3)	2 (Q2..Q3)
Current monitoring	2 (IQ16, IQ17) 0-1.0 A ±10%	-	-	-	-
Pluto safety bus	•	•	•	•	-
Pluto AS-i bus	-	-	-	-	-
Own current consumption	100...300 mA	100...300 mA	100...300 mA	100...300 mA	100...300 mA
Recommended external fuse	6A	6A	6A	6A	6A
Dimensions (w x h x d)	45 x 84 x 118 mm	45 x 84 x 118 mm	45 x 84 x 118 mm	45 x 84 x 118 mm	45 x 84 x 118 mm

Technical data - general

Colour	Grey
Operating voltage	24 VDC ±15%
Installation	35 mm DIN rail
Electrical insulation	Category II in accordance with IEC 61010-1
Safety level	
EN 954-1	Cat. 4
EN ISO 13849-1	PL e/Cat. 4
EN 61508	SIL 3
EN 62061	SIL 3
PFH _o	
Relay output	2.00×10 ⁻⁹
Transistor output:0	1.50×10 ⁻⁹
Failsafe inputs I & IQ	
I0..7 (I30..37, I40..47)	+24 V (for PNP sensors)
IQ10..17 (IQ20..27)	+24 V (for PNP sensors)
	IQ also configurable as non-failsafe outputs.
Current at 24 V	5.1 mA
Max. overvoltage	27 V continuous

Failsafe outputs Q	
Q2, Q3	Transistor, -24VDC, 800 mA
Output voltage tolerance	Supply voltage - 1.5 V at 800 mA
Q0, Q1, (Q4, Q5)	Relay outputs
	VAC-12: 250 V/1.5 A
	VAC-15: 250 V/1.5 A
	VDC-12: 50 V/1.5 A
	VDC-13: 24 V/1.5 A
Non-failsafe outputs Q	
IQ10..17 (IQ20..27)	Transistor +24V, PNP "open collector" also configurable as failsafe inputs.
Max. current/output	800 mA
Indicator	
Input/output LED	1 per I/O (green)
Display	7-segments, two characters
Pluto safety bus	
Max number of Pluto units on the databus	32
Databus type	CAN
Databus speeds	100, 125, 200, 250, 400, 500, 800, 1000 kb/s
Databus cable length	Up to 600 m, 150 m at 400 kb/s

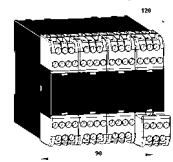
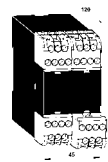
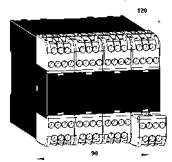
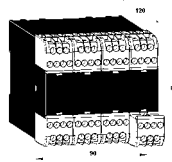
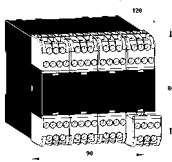

Pluto B46	Pluto D45	Pluto S46	Pluto AS-i	Pluto B42 AS-i
46 I/O	45 I/O Analogue/counter inputs	46 I/O Without safety bus	AS-i bus	AS-i bus
2TLA020070R1700	2TLA020070R6600	2TLA020070R1800	2TLA020070R1100	2TLA020070R1400
24 (I0..I7, I30..I37, I40..I47)	24 (I0..I7, I30..I37, I40..I47)	24 (I0..I7, I30..I37, I40..I47)	4 (I0..I3)	20 (I0..I3, I30..I47)
16 (IQ10..IQ17, IQ20..IQ27)	15 (IQ10..IQ17, IQ20..IQ26)	16 (IQ10..IQ17, IQ20..IQ27)	4 (IQ10..IQ13)	16 (IQ10..IQ27)
Max total load 2A	Max total load 2A	Max total load 2A	Max total load 2A	Max total load 2A
–	4*	–	–	–
–	8*	–	–	–
3 (I5..I7)	3 (IQ10..IQ12)	3 (I5..I7)	4 (IQ10..IQ13)	3 (I1..I3)
4 (Q0..Q1 & Q4..Q5)	4 (Q0..Q1 & Q4..Q5)	4 (Q0..Q1 & Q4..Q5)	2 (Q0..Q1)	4 (Q0..Q1 & Q4..Q5)
2 (Q2..Q3)	2 (Q2..Q3)	2 (Q2..Q3)	2 (Q2..Q3)	2 (Q2..Q3)
–	–	–	–	–
•	•	–	•	•
–	–	–	•	•
100...500 mA	100...500 mA	100...500 mA	100 mA	150 mA
10A	10A	10A	6A	10A
90 x 84 x 118 mm	90 x 84 x 118 mm	90 x 84 x 118 mm	45 x 84 x 118 mm	90 x 84 x 118 mm

*4 of the analogue inputs can be configured as counter inputs. The total number of analogue inputs + counter inputs = 8.

Pluto AS-i bus

Master profile	M2
Number of slave units	31/62*
Bus operation mode	Master
Safety monitor	Safety monitor, slave and safe I/O module.
Bus cable length:	Up to 500 m 100 m between each repeater

Temperature

Ambient temperature	–10°C to +50°C
Storage and transport	–25°C to +55°C

Response times

Dyn. A or static input to relay output	<20.5 ms + program exec. time
Dyn. A or static input to transistor output	<16.5 ms + program exec. time
Dyn. B or Dyn. C input to relay output	<23 ms + program exec. time
Dyn. B or Dyn. C input to transistor output	<19 ms + program exec. time
Software setting "NoFilt"	5 ms shorter response time on I & IQ inputs
AS-i bus to relay output	<33 ms + prog. execution time
AS-i bus to transistor output	<29 ms + prog. execution time

Additional Response times

Databus between Pluto units	10 ms
Databus between Pluto units at fault condition	10–40 ms

Enclosure classification

Enclosure	IP40, IEC 60 529
Connection terminals	IP20, IEC 60 529

The terminal blocks are detachable without needing to disconnect the wiring. The units shall be assembled with a gap of at least 5 mm.

APPLICATION EXAMPLE - Pluto

Robot cell with Pluto



Description

The example describes a processing machine served by a robot. The machine safety system consists of one (Pluto 1) to which all protection has been connected. The robot has been equipped with a (Pluto 0) to which the cell protection has been connected. The Pluto for the machine has been connected via a databus cable to the robot's Pluto so that common functions, such as emergency stop, can be used by the whole cell.

Function

Emergency stop takes priority and will stop both the machine and the robot. The machine hatch acts as the zone divider, when the hatch is closed the machine forms one zone and the robot another zone. When the machine hatch is open, both the machine and the robot belong to the same zone. If the door is opened when the machine hatch is open, the machine and the robot will both stop, but if the machine hatch is closed, only the robot will be stopped.

After the door has been opened, the system must be reset by means of the reset button on the outside of the door. Emergency stop is reset when the pressed-in button is pulled out. NOTE. The cell operating cycle must not however start immediately on resetting the emergency stop or the door.

Electrical connections

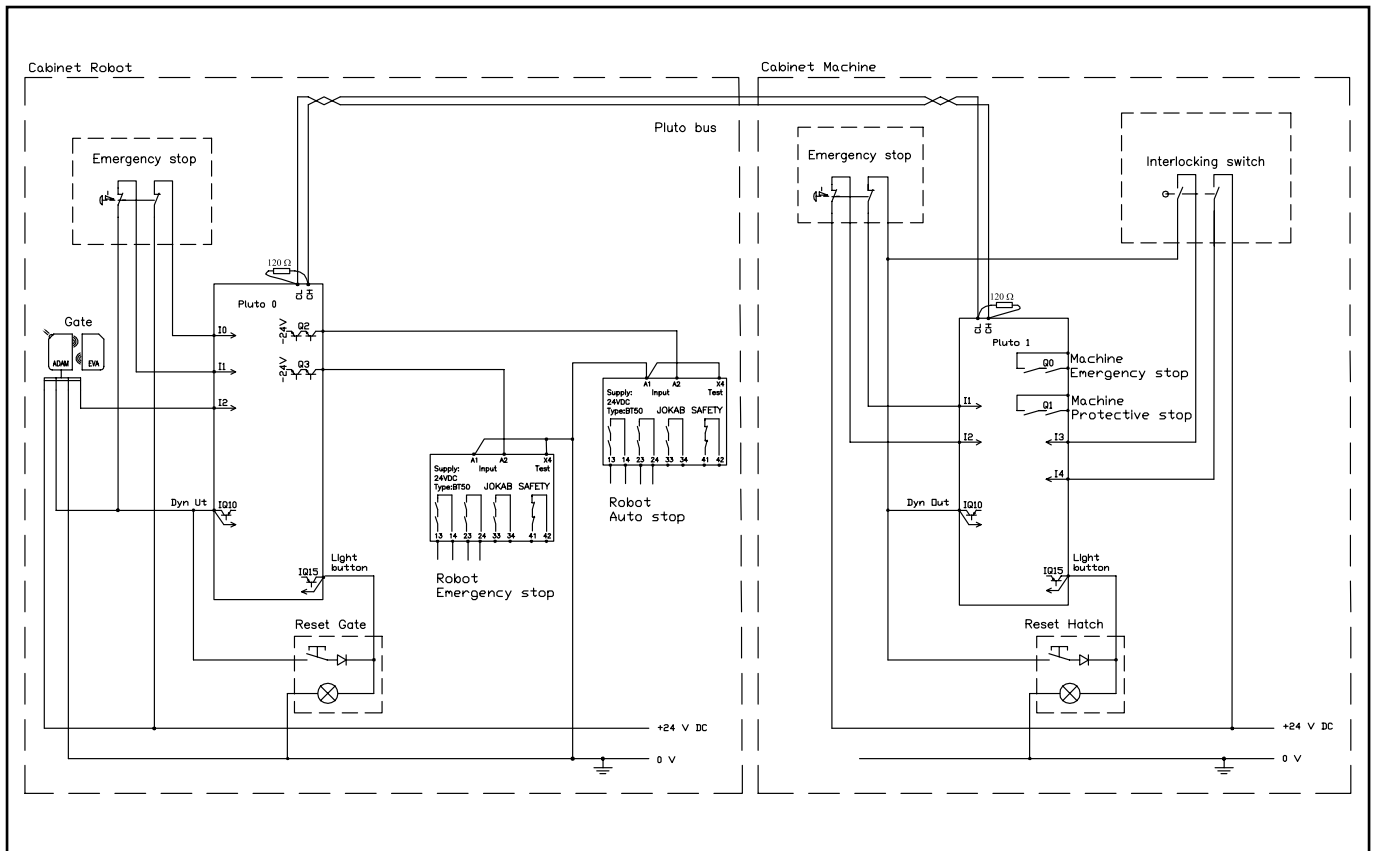

The screenshot shows the Pluto Manager software interface. The title bar reads "Pluto Manager - [Example]". The menu bar includes "File", "Search", "Tools", "Window", and "Help". The toolbar contains icons for "Open", "Save", "Print", "Comp.Down", "Online", "Start", "Bus St", and "AS-i St". The main workspace displays the following information:

- Project Name:** Example Robot cell
- Project Description:** Project created by: (empty), Project reviewed by: (empty), Project approved by: (empty). History: 2010-10-19 - Project created
- Function Libraries:** <func05.fps> (Change... button)
- Baudrate Pluto Carbus:** Default (400 kbit/s) (dropdown menu)
- Include source code in compiled file

The left sidebar shows a project tree with "Project Example" expanded to show "Pluto 0" and "Pluto 1", each with sub-items for "I/O Options", "Variables", and "Plc Code". The ABB logo is visible in the top right corner of the software window.

APPLICATION EXAMPLE - Pluto

PLC code Pluto 0 – Robot cabinet

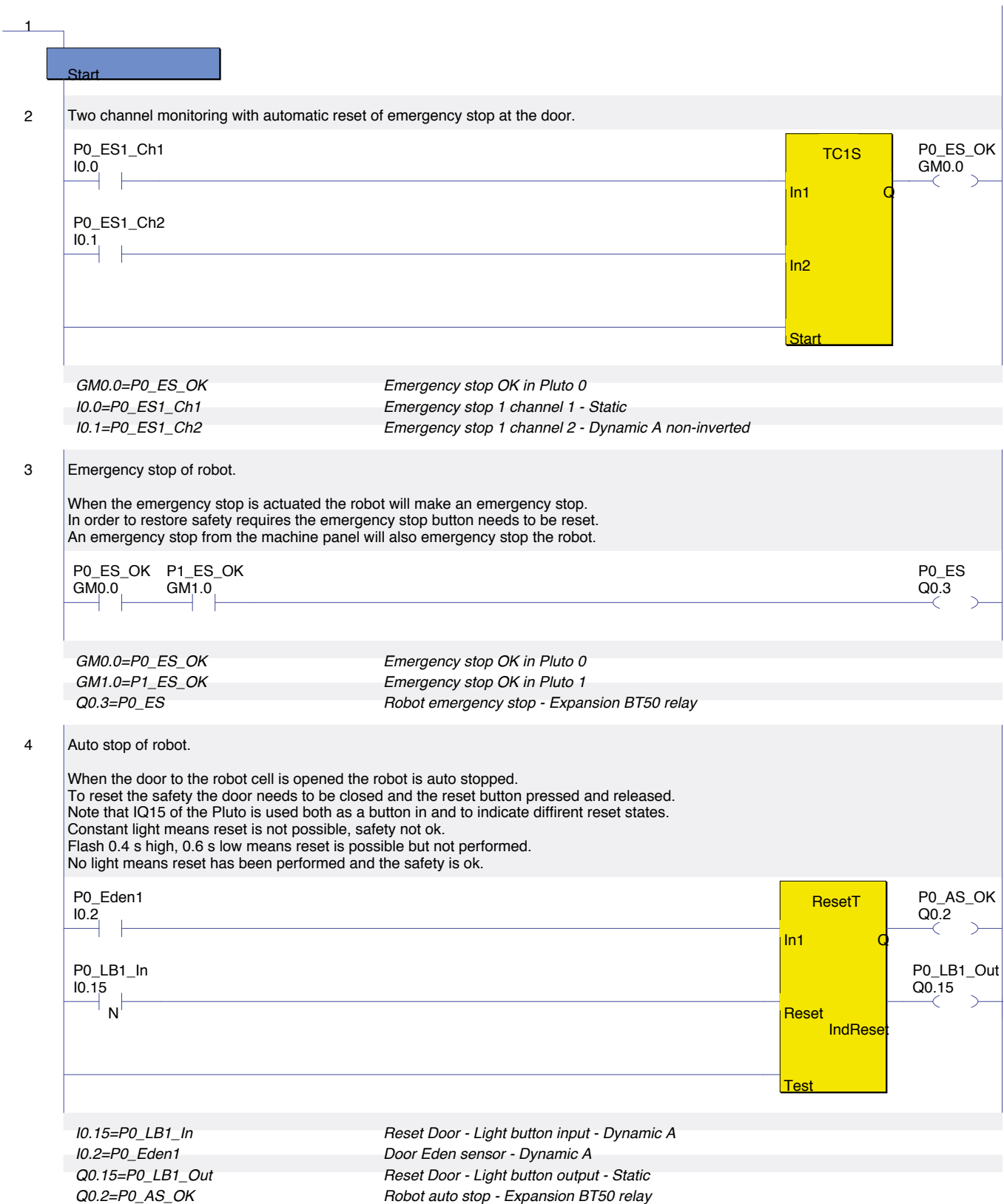

5 Alarm 03 - Machine hatch open.

To generate User Errors (UE) a value of 200 - 299 can be written to the display of the Pluto.
A check of System Register 11 (SR11) in the Pluto prioritises errors from the Pluto itself over User Errors.

P1_Hatch_OK GM1.1	P0_AS_OK Q0.2	SR_ErrorCode=0 SR0.11=0		SR_PlutoDisplay=203 SR0.10=203
----------------------	------------------	----------------------------	--	-----------------------------------

<i>GM1.1=P1_Hatch_OK</i>	<i>Hatch closed</i>
<i>Q0.2=P0_AS_OK</i>	<i>Robot auto stop - Expansion BT50 relay</i>
<i>SR0.10=SR_PlutoDisplay</i>	<i>Pluto display figure. For user error: 200+no</i>
<i>SR0.11=SR_ErrorCode</i>	<i>Error code</i>

6 Alarm 02 - Door open.

To generate User Errors (UE) a value of 200 - 299 can be written to the display of the Pluto.
A check of System Register 11 (SR11) in the Pluto prioritises errors from the Pluto itself over User Errors.

P0_Eden1 I0.2	SR_ErrorCode=0 SR0.11=0		SR_PlutoDisplay=202 SR0.10=202
------------------	----------------------------	--	-----------------------------------

<i>I0.2=P0_Eden1</i>	<i>Door Eden sensor - Dynamic A</i>
<i>SR0.10=SR_PlutoDisplay</i>	<i>Pluto display figure. For user error: 200+no</i>
<i>SR0.11=SR_ErrorCode</i>	<i>Error code</i>

7 Alarm 01 - Emergency stop actuated.

To generate User Errors (UE) a value of 200 - 299 can be written to the display of the Pluto.
A check of System Register 11 (SR11) in the Pluto prioritises errors from the Pluto itself over User Errors.

P0_ES_OK GM0.0	SR_ErrorCode=0 SR0.11=0		SR_PlutoDisplay=201 SR0.10=201
-------------------	----------------------------	--	-----------------------------------

<i>GM0.0=P0_ES_OK</i>	<i>Emergency stop OK in Pluto 0</i>
<i>SR0.10=SR_PlutoDisplay</i>	<i>Pluto display figure. For user error: 200+no</i>
<i>SR0.11=SR_ErrorCode</i>	<i>Error code</i>

APPLICATION EXAMPLE - Pluto

PLC code Pluto 1 – Machine cabinet

2

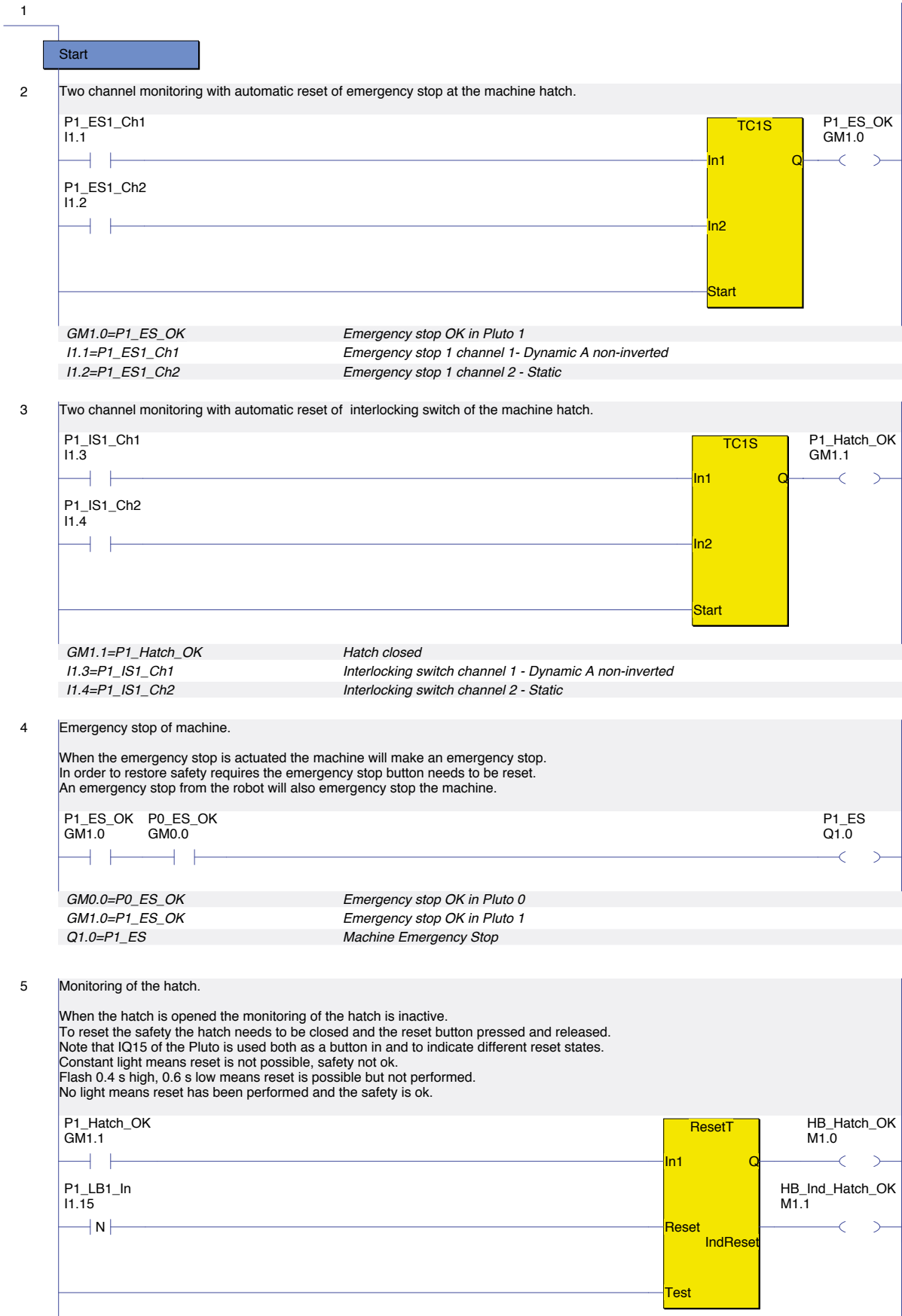

GM1.1=P1_Hatch_OK	Hatch closed
I1.15=P1_LB1_In	Reset Hatch - Light button input - Dynamic A
M1.0=HB_Hatch_OK	Help Bit - Hatch closed
M1.1=HB_Ind_Hatch_OK	Help Bit - Indication Reset Hatch

6 Light button indication of the reset of the hatch.
 If the robot cell's door is closed and reset no light indication is needed inside the cell.



7 Protective stop of the machine.
 Either the hatch is closed and reset or the door to the robot cell is closed and reset.
 This means the cell can work with the hatch both open or closed as long as the cell's door is closed and reset.

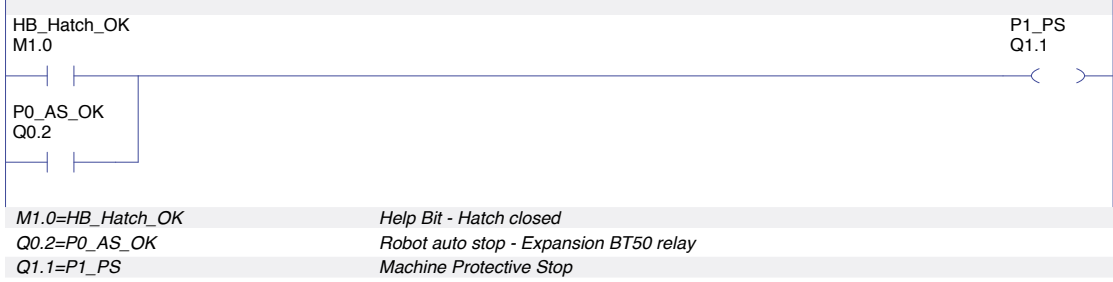

8 Alarm 03 - Machine hatch open.
 To generate User Errors (UE) a value of 200 - 299 can be written to the display of the Pluto.
 A check of System Register 11 (SR11) in the Pluto prioritises errors from the Pluto itself over User Errors.

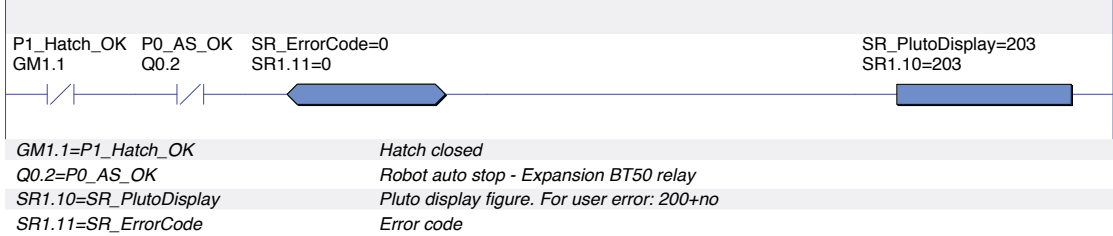

9 Alarm 02 - Door open.
 To generate User Errors (UE) a value of 200 - 299 can be written to the display of the Pluto.
 A check of System Register 11 (SR11) in the Pluto prioritises errors from the Pluto itself over User Errors.

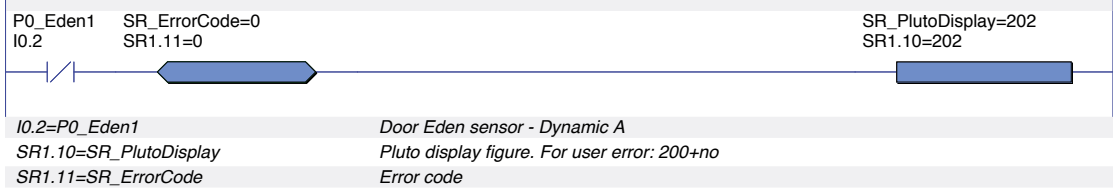

10 Alarm 01 - Emergency stop actuated.
 To generate User Errors (UE) a value of 200 - 299 can be written to the display of the Pluto.
 A check of System Register 11 (SR11) in the Pluto prioritises errors from the Pluto itself over User Errors.

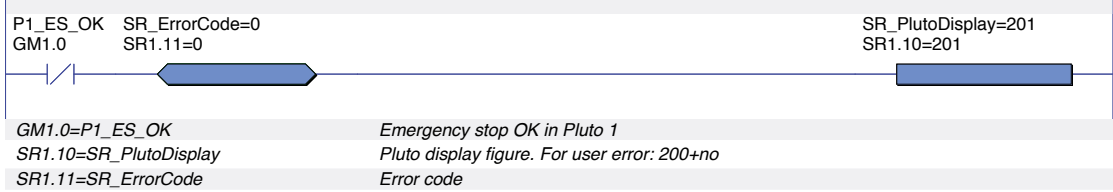

Pluto gateway GATE-P2

2



- Profibus DP
- DeviceNet
- CANopen
- Profinet
- Ethernet/IP
- Modbus TCP

Use:

- Bi-directional status information from the Pluto safety PLC
- For Profibus

Features:

- Two-way communication
- Built-in filter function, shared network
- Only 22.5 mm wide
- Can be located anywhere in the databus
- Common interface with Pluto
- Ready-made function blocks

Pluto gateway is a unit providing two-way communication between a Pluto safety PLC and other field buses.

The Pluto gateway is a compact unit mounted on a DIN rail, and can be connected anywhere in a Pluto safety bus. The unit has a common interface with Pluto, i.e. the same cabling, and the Pluto Manager PC program can be used for servicing and where necessary programming. Normally, however, all the settings are made via DIP switches, which means that programming tools are not required to put the gateway itself into operation.

For programming Pluto there are ready-made function blocks which, via a Pluto gateway, send and receive data from the supervisory system.

Data from Pluto

Via PROFIBUS a supervisory PLC system can have access to the I/O and other variables in a Pluto safety PLC. Global I/O in a Pluto safety PLC are accessible via PROFIBUS modules in the gateway, one module for each Pluto unit. Local data in Pluto units can be read by a "local data" module together with the PLC codes in the supervisory system.

Data to Pluto

Via PROFIBUS a supervisory PLC system can transmit non-safety-related information to a Pluto safety PLC. A total of 64 Boolean values and 8 different 16-bit registers can be transmitted. Function blocks for these functions are available in Pluto Manager.

PLC function blocks

To simplify the integration of a Pluto gateway PROFIBUS into the supervisory PLC system, ABB Jokab Safety provides ready-made function blocks for several popular brands of PLC. The function blocks make it easier to receive and send information to the Pluto system. The function blocks are supplied as open units with full access for the customer to change and add functions. These function blocks can be obtained via www.abb.com/jokabsafety.

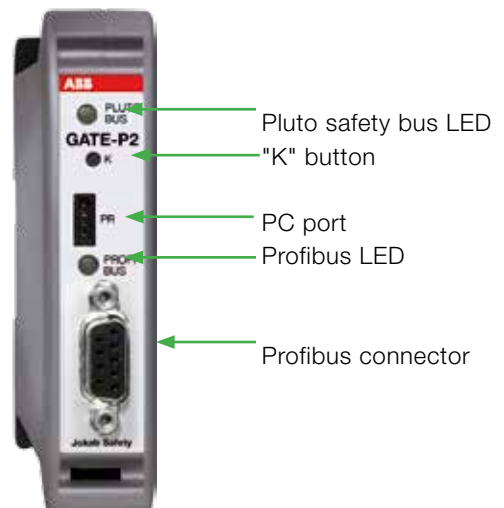

Technical data - GATE-P2

Article number	2TLA020071R8000
Databases	-Pluto safety bus CAN (isolated) -PROFIBUS RS485 (isolated)
Pluto safety bus speeds	100, 200, 250, 400, 500, 800 and 1000 kbit/s (automatic speed detection)
PROFIBUS speed	Up to 12 Mbit/s (automatic speed detection)
PROFIBUS address	Setting via DIP switches (0-99)
PROFIBUS version	DP slave, DP-V0
Connections	Top, 3-pole terminal for Pluto safety bus (included) Front, standard 9-pole PROFIBUS connection. Bottom, 2-pole terminal for 24 VDC (included)
Status indication	Pluto safety bus status indication via LED PROFIBUS status indication via LED
Operating voltage	24 VDC, -15% till +20%
Current at 24 V	< 100 mA (recommended fuse ≤6 A)
Dimensions (w x h x d)	22.5 x 101 x 119 mm
Installation	35 mm DIN rail
Operating temperature (ambient)	-10°C to + 55°C
Temperature, transport and storage	-25°C to + 55°C
Humidity	EN 60 204-1 50% at 40°C (ambient 90% at 20°C)
Enclosure classification	Enclosure IP20 - IEC 60 529 Terminals IP20 - IEC 60 529

2

Gateway block schematic diagram - Pluto Profibus

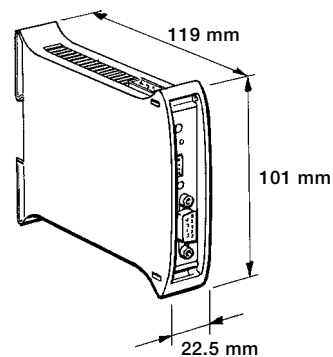
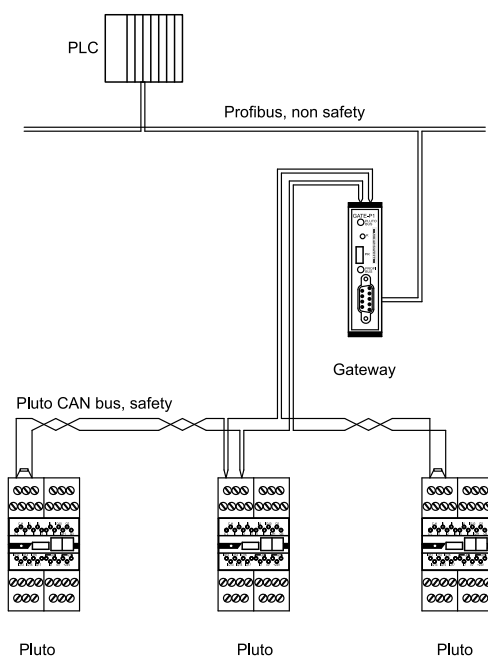

Pluto gateway GATE-D2

2



- Profibus DP
- DeviceNet
- CANopen
- Profinet
- Ethernet/IP
- Modbus TCP

Use:

- Bi-directional status information from the Pluto safety PLC
- For DeviceNet and Pluto bridge

Features:

- Two-way communication
- Built-in filter function, shared network
- Only 22.5 mm wide
- Can be located anywhere in the databus
- Common interface with Pluto
- Ready-made function blocks

Pluto gateway is a unit providing two-way communication between a Pluto safety PLC and other field buses.

The Pluto gateway is a compact unit mounted on a DIN rail, and can be connected anywhere in a Pluto safety bus. The unit has a common interface with Pluto, i.e. the same cabling, and the Pluto Manager PC program can be used for servicing and where necessary programming. Normally, however, all the settings are made via DIP switches, which means that programming tools are not required to put the gateway itself into operation.

For programming Pluto there are ready-made function blocks which, via a Pluto gateway, send and receive data from the supervisory system.

Data from Pluto

Via DeviceNet a supervisory PLC system can have access to the I/O and other variables in a Pluto safety PLC. Global I/Os in a Pluto safety PLC are accessible via DeviceNet "implicit" messages. Local data in Pluto units can be read via DeviceNet "explicit" messages.

Data to Pluto

Via DeviceNet a supervisory PLC system can transmit non-safety-related information to a Pluto safety PLC. A total of 64 Boolean values and 8 different 16-bit registers can be transmitted (via DeviceNet "implicit" or "explicit" messages). Function blocks for these commands are available in Pluto Manager.

Pluto bridge

A GATE-D2 can also be used to advantage as a CAN bridge when it is required to divide a Pluto safety bus into several sections. This is particularly useful when long databus cables are needed.

There is also a built-in filter function which makes it possible to block any data that is not required for use on the other side of the bridge, which reduces the databus loading in the other sections and thereby permits longer databus cables.

ABB Robotics IRC5

PLUTO GATE-D2 has support for integration into an ABB Robotics IRC5-system. The documentation that describes this integration can be obtained via www.abb.com/jokabsafety.



Technical data - GATE-D2

Article number	2TLA020071R8200
Databases	-Pluto safety bus CAN (isolated) -DeviceNet CAN (isolated)
Pluto safety bus speeds	100, 200, 250, 400, 500, 800 and 1000 kbit/s (automatic speed detection)
DeviceNet speed	125, 250 and 500 kbit/s (set via DIP switch)
DeviceNet address	Setting via DIP switches (1-63)
DeviceNet Version	ODVA version 2.0
Connections	Top, 3-pole terminal for Pluto safety bus (included) Front, 5-pole terminal for DeviceNet (included) Bottom, 2-pole terminal for 24 VDC (included)
Status indications	Pluto safety bus status indication via LED DeviceNet MNS status indication via LED
Operating voltage	24 VDC, -15% till +20%
Current at 24 V	< 100 mA (recommended fuse ≤6 A)
Dimensions (w x h x d)	22.5 x 101 x 119 mm
Installation	35 mm DIN rail
Operating temperature (ambient)	-10°C to + 55°C
Temperature, transport and storage	-25°C to + 55°C
Humidity	EN 60 204-1 50% at 40°C (ambient 90% at 20°C)
Enclosure classification	Enclosure IP20 - IEC 60 529 Terminals IP20 - IEC 60 529

2

Gateway block schematic diagram - Pluto DeviceNet

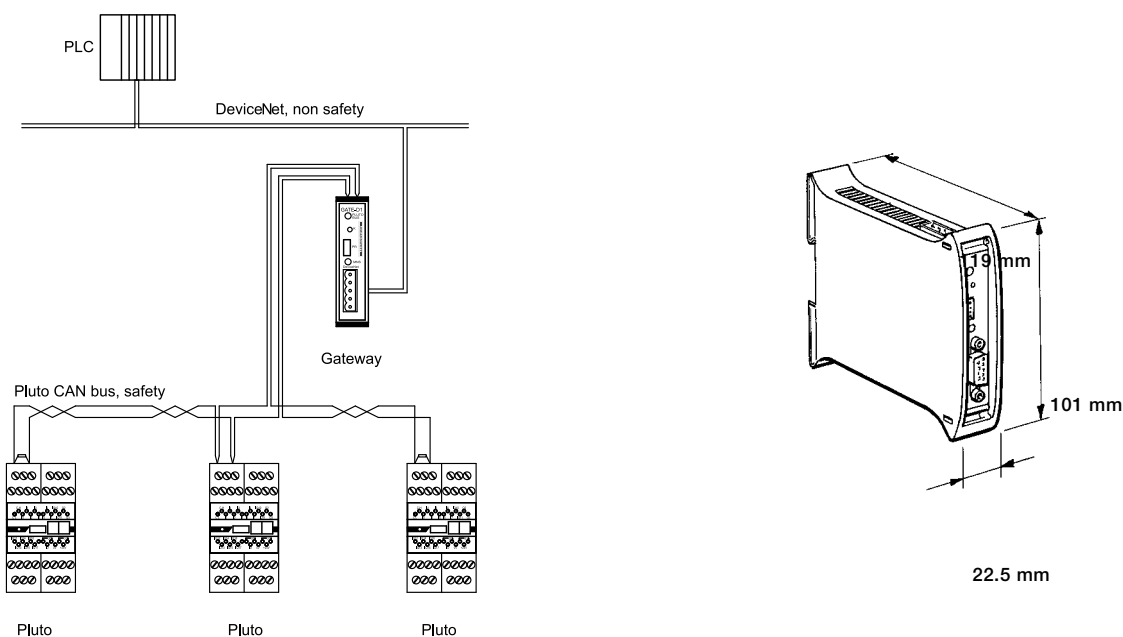

Pluto gateway GATE-C2

2



- Profibus DP
- DeviceNet
- CANopen
- Profinet
- Ethernet/IP
- Modbus TCP

Use:

- Bi-directional status information from the Pluto safety PLC
- For CANopen and Pluto-bridge

Features:

- Two-way communication
- Built-in filter function, shared network
- Only 22.5 mm wide
- Can be located anywhere in the databus
- Common interface with Pluto
- Ready-made function blocks

Pluto gateway is a unit providing two-way communication between a Pluto safety PLC and other field buses.

The Pluto gateway is a compact unit mounted on a DIN rail, and can be connected anywhere in a Pluto safety bus. The unit has a common interface with Pluto, i.e. the same cabling, and the Pluto Manager PC program can be used for servicing and where necessary programming. Normally, however, all the settings are made via DIP switches, which means that programming tools are not required to put the gateway itself into operation.

For programming Pluto there are ready-made function blocks which, via a Pluto gateway, send and receive data from the supervisory system.

Data from Pluto

Via CANopen a supervisory PLC system can have access to the I/O and other variables in a Pluto safety PLC. Global I/Os in a Pluto safety PLC are accessible via CANopen PDO messages. Local data in Pluto units can be read via CANopen SDO messages together with the PLC codes in the supervisory system.

Data to Pluto

Via CANopen a supervisory PLC system can send non-safety-related information to a Pluto safety PLC. A total of 64 Boolean values and 8 different 16-bit registers can be transmitted (CANopen PDO or SDO messages). Function blocks for these commands are available in Pluto Manager.

Pluto bridge

A GATE-C2 can also be used to advantage as a CAN bridge when it is required to divide a Pluto safety bus into several sections. This is particularly useful when long databus cables are needed.

There is also a built-in filter function which makes it possible to block any data that is not required for use on the other side of the bridge, which reduces the databus loading in the other sections and thereby permits longer databus cables.



Technical data - GATE-C2

Article number	2TLA020071R8100
Databuses	-Pluto safety bus CAN (isolated) -CANopen CAN (isolated)
Pluto safety bus speeds	100, 200, 250, 400, 500, 800 and 1000 kbit/s (automatic speed detection)
CANopen speeds	125, 250 and 500 kbit/s (set via DIP switch) 10, 20, 50, 100, 125, 250, 500, 800 and 1000 kbit/s (via software)
CANopen address	Setting via DIP switches or software (1-63)
CANopen version	"Version 4.02 of the CiA Draft Standard 301"
Connections	Top, 3-pole terminal for Pluto safety bus (included) Front, 5-pole terminal for CANopen (included) Bottom, 2-pole terminal for 24 VDC (included)
Status indications	Pluto safety bus status indication via LED CANopen status indication via LED
Operating voltage	24 VDC, -15% till +20%
Current at 24 V:	< 100 mA (recommended fuse ≤6 A)
Dimensions (w x h x d)	22.5 x 101 x 119 mm
Installation	35 mm DIN rail
Operating temperature (ambient)	-10°C to + 55°C
Temperature, transport and storage	-25°C to + 55°C
Humidity	EN 60 204-1 50% at 40°C (ambient 90% at 20°C)
Enclosure classification	Enclosure IP20 - IEC 60 529 Terminals IP20 - IEC 60 529

2

Gateway block schematic diagram - Pluto CANopen

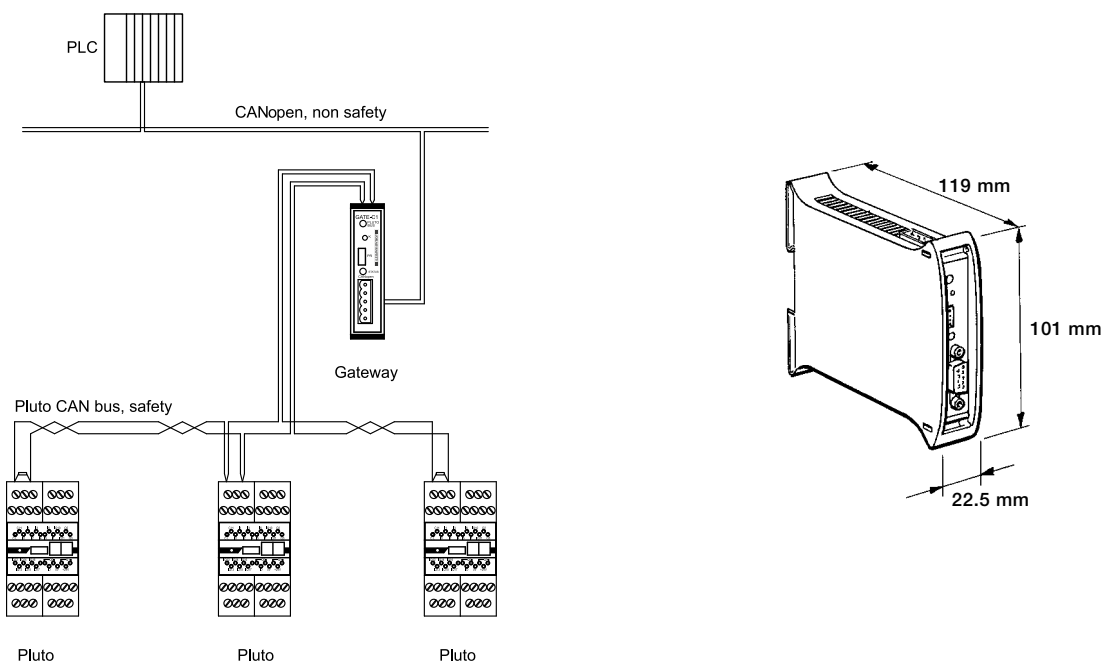

Pluto gateway GATE-E2

2



- Profibus DP
- DeviceNet
- CANopen
- Profinet
- Ethernet/IP
- Modbus TCP

Use:

- Bi-directional status information from the Pluto safety PLC
- Profinet, Ethernet/IP, Modbus TCP

Features:

- Two-way communication
- Built-in filter function, shared network
- Can be located anywhere in the databus
- Common interface with Pluto
- Ready-made function blocks

Pluto gateway is a unit providing two-way communication between a Pluto safety PLC and other field buses.

The Pluto gateway is a compact unit mounted on a DIN rail, and can be connected anywhere in a Pluto safety bus. The unit has a common interface with Pluto, i.e. the same cabling, and the Pluto Manager PC program can be used for servicing and where necessary programming. Normally, however, all the settings are made via DIP switches, which means that programming tools are not required to put the gateway itself into operation.

For programming Pluto there are ready-made function blocks which, via a Pluto gateway, send and receive data from the supervisory system.

Protocol

PLUTO Gateway GATE-E2 handles the status from and to Pluto safety PLCs via Ethernet protocols EtherNet/IP, PRO-FINET, Modbus TCP and a simple binary protocol that uses TCP/IP.

For IP-address configuration, etc. there is a simple web server and a terminal server.

Data from Pluto

Via one of the Ethernet protocols a supervisory PLC system can have access to the I/O and other variables in a Pluto safety PLC. Global I/Os in a Pluto safety PLC are accessible via the usual I/O transfer in the respective protocol. Local data in Pluto units can be read by special commands together with the PLC codes in the supervisory system.

Data to Pluto

Via the Ethernet protocol a supervisory PLC system can transmit non-safety-related information to a Pluto safety PLC. A total of 64 Boolean values and 8 different 16-bit registers can be transmitted. Function blocks for these functions are available in Pluto Manager.

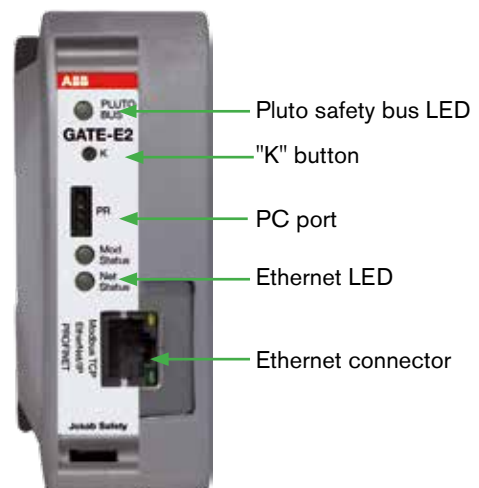

Technical data - GATE-E2

Article number	2TLA020071R8300
Buses	Pluto-bus CAN (isolated) Profinet (isolated) Ethernet/IP (isolated) Modbus TCP (isolated)
Pluto safety bus speeds	100, 200, 250, 400, 500, 800 and 1000 kbit/s (automatic speed detection)
Ethernet	10/100 Mbit/s Half and full duplex
Ethernet protocol	Status from and to Pluto safety PLC - EtherNet/IP - PROFINET - Modbus TCP - Binary server (TCP/IP) Note that certain combinations of server protocols cannot be used simultaneously. Gateway status and IP address configuration - Web server - Terminal server (TCP/IP)
EtherNet/IP	According to ODVA "CIP Edition 3.2" and "EtherNet/IP Adaption of CIP Edition 1.3". Minimum RPI of 50 ms
PROFINET	PROFINET
Modbus TCP	According to the Modbus organisation, version 1.0b (approx. 20 messages per second).
Binary server (TCP/IP)	Simple TCP/IP protocol to send status from/to the Pluto system.

Web server	For simple sharing of IP addresses.
Terminal server (TCP/IP)	Simple server with the same commands as via the serial programming port in the unit.
IP address	Static sharing via web server or via programming port.
Gateway configuration	Takes place via EtherNet/IP, PROFINET, Modbus TCP or via the binary TCP/IP server.
Connections	Top, 3-pole terminal for Pluto safety bus (included) Front, Ethernet connection via RJ-45 (screened cable cat. 5e FTP) Bottom, 2-pole terminal for 24 VDC (included)
Status indications	Pluto safety bus status indication via LED (Pluto safety bus) Ethernet module status indication via LED (Mod Status) Ethernet network status indication via LED (Net Status)
Operating voltage	24 VDC, -15 % till +20 %
Current at 24 V	< 150 mA (recommended fuse ≤6 A)
Dimensions (w x h x d)	35 x 101 x 120 mm
Installation	35 mm DIN rail
Operating temperature (ambient)	-10°C to + 55°C
Temperature, transport and storage	-25°C to + 55°C
Humidity	EN 60 204-1 50 % at 40°C (ambient) 90 % at 20°C)
Enclosure classification	Enclosure IP20 - IEC 60 529 Terminals IP20 - IEC 60 529

Gateway block schematic diagram - Pluto Ethernet

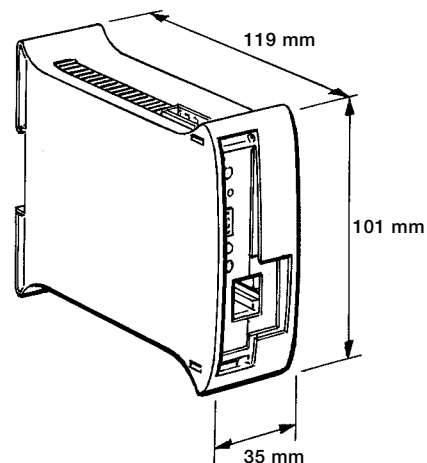
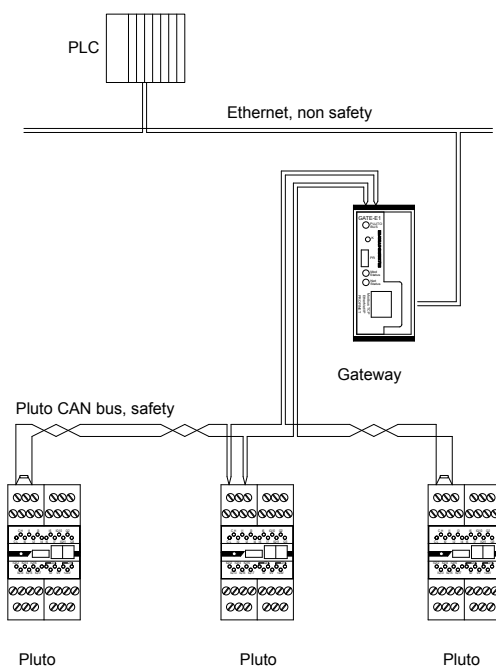

Pluto Safe Encoder

2



Use:

- Safe position and speed determination of machine movements.

Features:

- High resolution
- Selectable resolution
- Connected directly to the Pluto safety bus
- Ready-made function blocks

Rotational absolute value sensor for safe positioning

Together with a Pluto safety PLC, this rotational absolute encoder can be used for safe position determination. This is particularly useful with equipment such as gantry robots, industrial robots, etc. Also in eccentric shaft presses, existing cam mechanisms can be replaced by absolute value position sensors for safe positioning. The sensors are available in single and multi-turn versions.

Up to 16 absolute encoders can be connected to a Pluto CAN databus. A Pluto on the databus reads the sensor values, which are evaluated. With a special function block in the PLC code, it is possible to design two-channel solutions with the sensors. The user can obtain safe values for position and speed from these values. This enables supervision of stationary and overspeed conditions.

The absolute value sensors are standard sensors with modified software to meet the safety requirements.

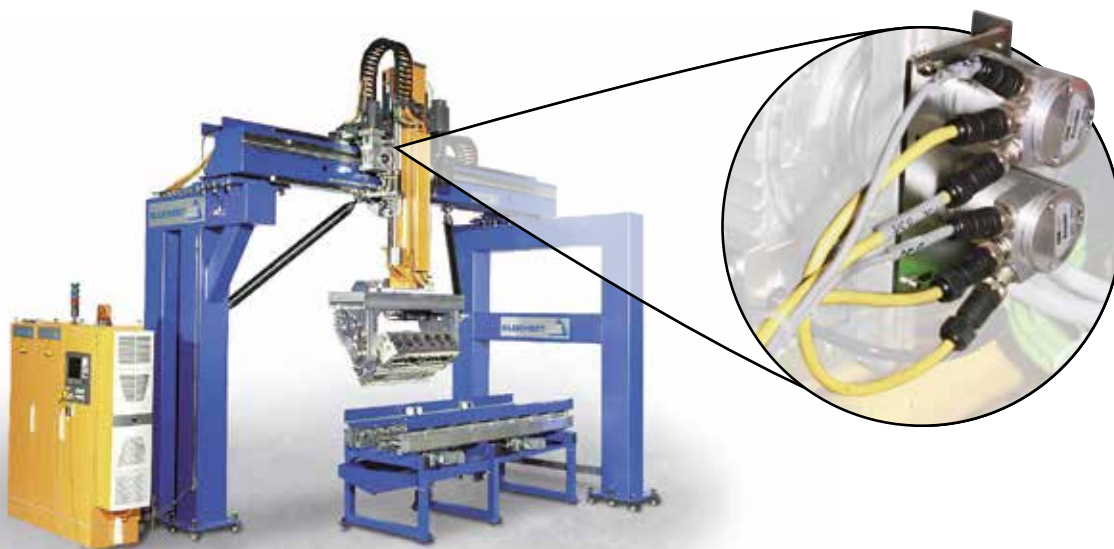

Example of an application where 2 sensors provide safe position determination in a gantry robot.

Technical data – Safe Encoder RSA 597/RHA 597

Article number	2TLA020070R3600 2TLA020070R3300 2TLA020070R3400 2TLA020070R5900
Ambient temperature	-40°C .. +70°C
Temperature, transport and storage	-30°C .. +70°C
Ingress protection class	IP-67 in accordance with IEC 60529
At shaft inlet	IP-66 in accordance with IEC 60529
Vibration (55 to 2000 Hz)	< 300 m/s ² in accordance with IEC 60068-2-6
Shock (6ms)	< 2000 m/s ² in accordance with IEC 60068-2-27
Material, enclosure	Aluminium
Surface treatment	Painted and chromed or anodised
Weight	Approx. 300 g
Accuracy and resolution	
Resolution	13 bits, 8192 positions per rotation
Accuracy	± ½ LSB (Least Significant Bit)
Operating voltage	9-36 VDC
Polarity-protected	Yes
Short-circuit protected	Yes
Databus speed	5 kbit/s - 1 Mbit/s, preset at 500kbit/s
Address input	Active low
Code type	Binary
Programmable functions	Resolution, 0 position Direction, Databus speed
Current consumption	50 mA at 24 VDC
Max current consumption	100 mA

2

Ordering details

Shaft	Connnection	Type	Order code
Ø 10 mm with face	12-pole connector	RSA 597	2TLA020070R3600
Ø 6 mm with face	1.5 m cable	RSA 579 RSA 597	2TLA020070R3300*
Hollow shaft Ø 12 mm	2 m cable	RHA 597	2TLA020070R3400*
Hollow shaft Ø 12 mm	10 m cable	RHA 597	2TLA020070R5900*

*Ordering product

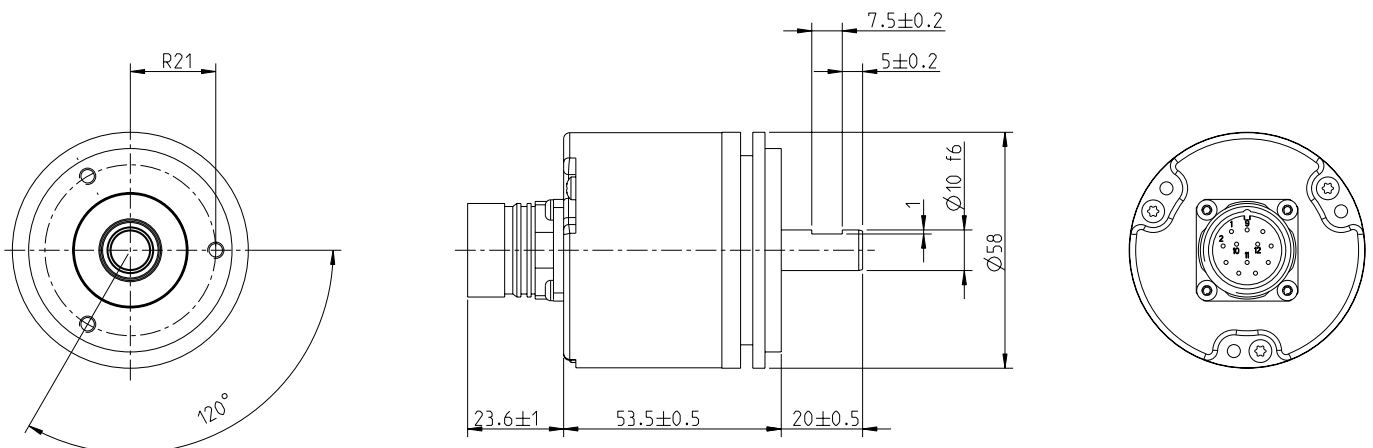

Technical data – Safe Encoder RSA 698/RHA 698

Article number	2TLA020070R3700 2TLA020070R7800 2TLA020070R7900
Ambient temperature	-40°C .. +70°C
Temperature, transport and storage	-30°C .. +70°C
Ingress protection class	IP67 in accordance with IEC 60529
At shaft inlet	IP66 in accordance with IEC 60529
Vibration (55 to 2000 Hz)	< 100 m/s ² in accordance with IEC 60068-2-6
Shock (6ms)	< 2000 m/s ² in accordance with IEC 60068-2-27
Material, enclosure	Aluminium
Surface treatment	Anodised
Weight	Approx. 400g
Accuracy and resolution	
Resolution, total	25 bit 13 bits, 8192 positions per rotation 12 bits, 4096 rotations
Accuracy	± 1 LSB (Least Significant Bit)
Operating voltage	9-36 VDC
Polarity-protected	Yes
Short-circuit protected	Yes
Databus speed	10 kbit/s - 1 Mbit/s
Code type	Binary
Programmable functions	Resolution, 0 position
Current consumption	50 mA at 24 VDC
Max current consumption	100 mA

Ordering details

Shaft	Connexion	Type	Order code
Ø 10 mm round	M12 5-pole connector	RSA 698	2TLA020070R3700
Ø 6 mm round	M12 5-pole connector	RSA 698	2TLA020071R7800*
Hollow shaft Ø 12 mm	M12 5-pole connector	RHA 698	2TLA020071R7900*

*Ordering product

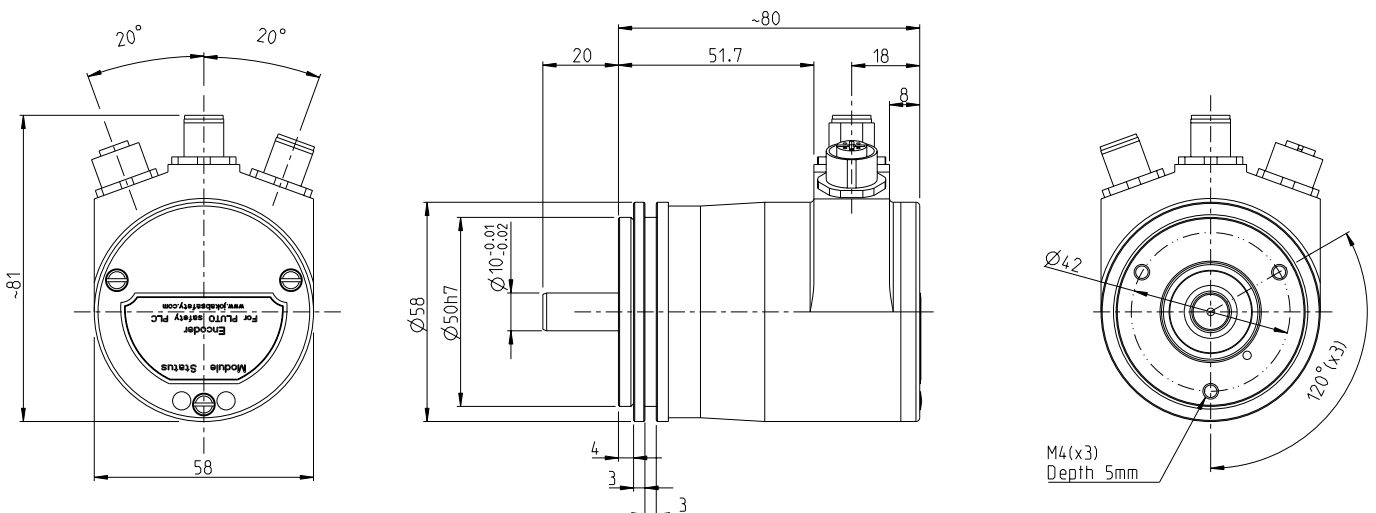

Safe Encoder

Function block for two single-turn encoders that generates safe position and speed values.

Function

The block reads and evaluates two absolute encoders. The position value is sent to the 'Position' output. The 'Speed' output is the average value for the speed, at the rate of pulses/10 ms. If an error occurs, the 'OK' output is set to zero. In certain applications the values of 'Position' and 'Speed' are used in conjunction with the 'OK' output.

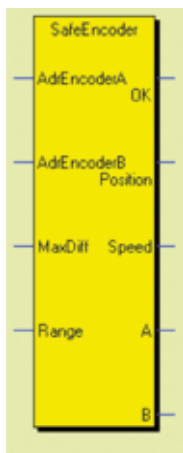

Descriptions of inputs and outputs

- AdrEncoderA: Encoder A node address
- AdrEncoderB: Encoder B node address
- MaxDiff: Max allowed deviation between the encoders (max 2% of Range)
- Range: Number of increments per revolution
- OK: Set when encoders are working OK and the position values are within the margin set by 'MaxDiff'
- Position: Position value
- Speed: Speed value as increments/10ms
- A: Encoder A position. Must not be used in PLC program!
- B: Encoder B position. Must not be used in PLC program!

NOTE! Position values from single encoders are only available for adjustment purposes and must NOT be used for safety.

NOTE! When error occurs 'Position' = -1, 'Speed' = -32768 and the OK output will be reset.

Safe Encoder Multiturn

Function block for two multi-turn encoders that generates safe position and speed values.

Function

The block reads and evaluates two absolute encoders. The average value for the two sensors is calculated and sent to the 'Position' output. The 'Speed' output is the average value for the speed, at the rate of pulses/10 ms. The block monitors that the encoder position values do not differ by more than the input value set by 'MaxDiff'. If an error occurs, the 'OK' output is set to zero. In certain applications the values of 'Position' and 'Speed' are used in conjunction with the 'OK' output.

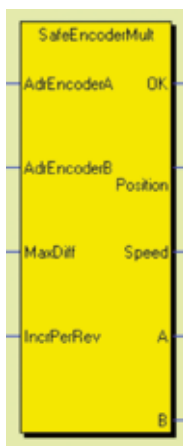

Descriptions of inputs and outputs

- AdrEncoderA: Encoder A node address
- AdrEncoderB: Encoder B node address
- MaxDiff: Max allowed deviation between the encoders (max 2% of IncrPerRev)
- IncrPerRev: Number of increments per revolution
- OK: Set when encoders are working OK and the position values are within the margin set by 'MaxDiff'
- Position: Position value
- Speed: Speed value as increments/10ms
- A: Encoder A position. Must not be used in PLC program!
- B: Encoder B position. Must not be used in PLC program!

NOTE! Position values from single encoders are only available for adjustment purposes and must NOT be used for safety.

NOTE! When error occurs 'Position' = -1, 'Speed' = -32768 and the OK output will be reset.

Encoder Cam

Function block for electronic cam gear.

Function

Output Q is activated if the value of the input register 'PosReg' is within the limits for 'MinPos' and 'MaxPos'.

NOTE! It is possible to specify a value that defines the sensor's zero position. Position <0 is not permitted.

Example: If MinPos = 3000 and MaxPos = 200, Q is activated when the position is greater than 2999 or less than 201.

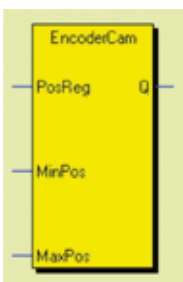

Descriptions of inputs and outputs

- PosReg: Input for the position value
- MinPos: Minimum limit value
- MaxPos: Maximum limit value

Pluto identifier IDFIX

Use:

- Gives each Pluto unit an identity on the bus
- For storage of the PLC program
- For storage of the AS-i safety codes

2



IDFIX is an identifier circuit which gives each Pluto an address on the bus. It contains an identification code which can be read by the system. The identification code is declared in the PLC program so that the correct part of the PLC program is executed by each specific Pluto. The use of IDFIX is mandatory in a multi-Pluto project, but voluntary if a unit works alone. If one Pluto in a multi-Pluto project needs to be replaced it is possible to let the new Pluto self load the PLC program from another Pluto on the bus. The IDFIX will ensure that the new Pluto has the correct address on the bus.

Five different versions of IDFIX

- R is preprogrammed.
- RW is programmable.
- DATA is programmable and can also store the AS-i safety codes.
- PROG 2k5 is for single-Pluto projects only, and has a 2.3 kbyte memory for storage of the PLC program. It can also store the AS-i safety codes in the same way as IDFIX-DATA.
- PROG 10k works in the same way as PROG 2k5, but it has a larger memory (10 kbyte).

IDFIX is connected between the input terminals ID and 0V.

IDFIX-DATA

IDFIX-DATA is for Pluto AS-i and B42 AS-i, and contains a memory for storage of the AS-i safety codes.

IDFIX-PROG

IDFIX-PROG contains a memory for storage of the PLC program for single-Pluto projects. When a program is downloaded to Pluto the IDFIX-PROG will automatically be updated. If the Pluto unit needs to be replaced, the new Pluto can self load the PLC program from IDFIX-PROG by pressing the K button (in the same way as a Pluto can self load the program over the CAN bus). Only one Pluto is allowed in the project and the IDFIX code is always EEEEEEEEEEE0. IDFIX-PROG can also store the AS-i safety codes in the same way as IDFIX-DATA.

NOTE! "Single-Pluto project" means that the PLC program only contains one Pluto. It is still possible to connect several "Single-Pluto projects", each with its own program and IDFIX-PROG, together via the Pluto bus.



AS-i Safety

Two-wire bus system

Why should I use the bus system at component level?	3/3
Pluto AS-i Safety – Safety is now simple!	3/5
A Pluto AS-i can be used in three ways	3/7
Sensors with built in AS-i safety nodes	3/8

Safety node Urax

Urax-A1/A1R	3/9
Urax-B1R	3/11
Urax-C1/C1R	3/13
Urax-D1R	3/15
Urax-E1	3/17

Why should I use the bus system at component level?

3

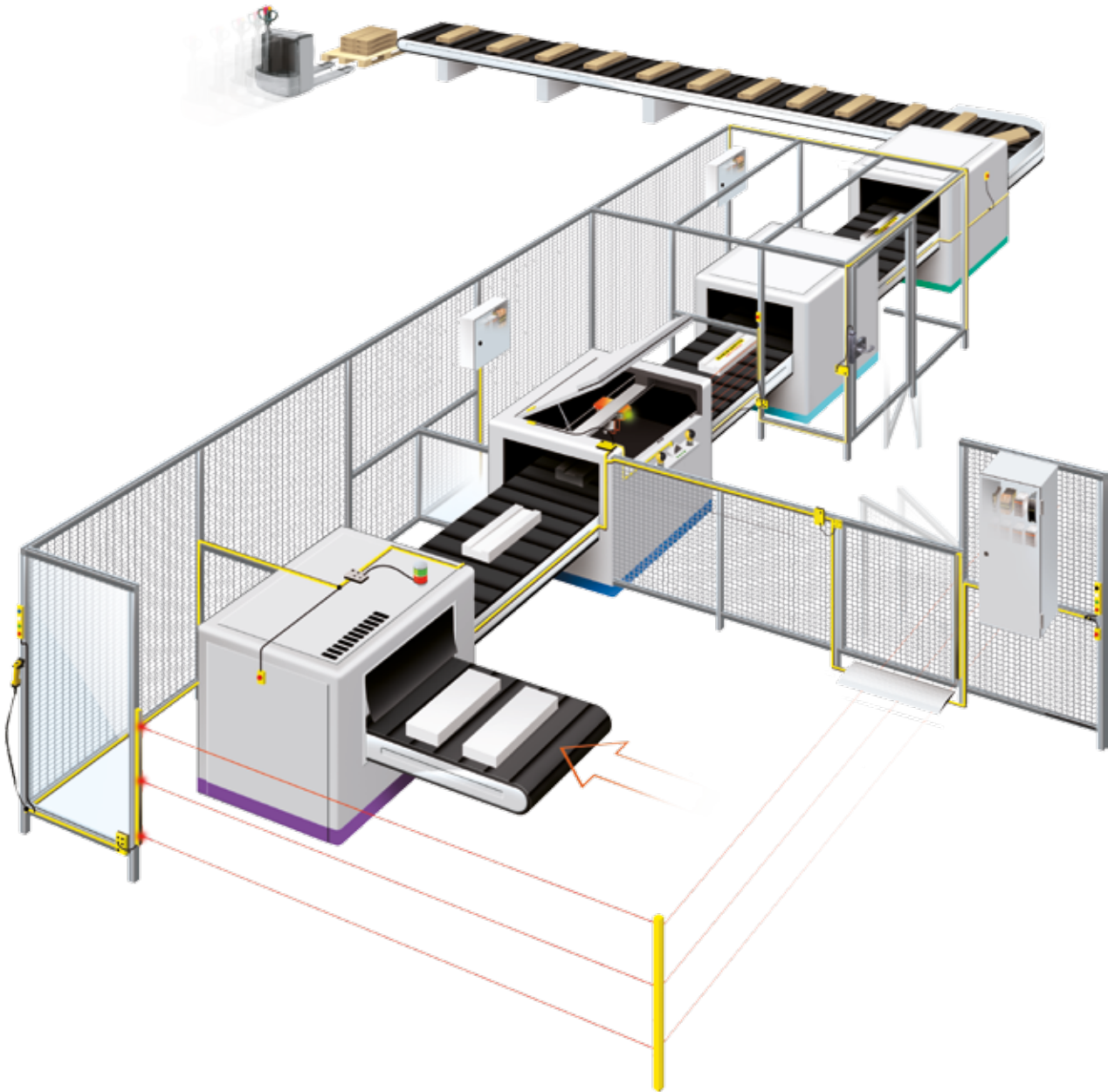

– to save installation time

Components designed for the AS-i bus system can easily connect to the network wherever this is required. The required function is then selected in the control system.

– as it provides a flexible system

You can use the AS-i cable to move, replace or add new safety products anywhere as needed. Additional monitors such as Pluto AS-i can also be connected in the same way.

– provides simplicity in the construction of systems

The AS-i system provides benefits both when the system is planned and installed. A single network can, for example, be divided into monitoring and control of different work zones. The zones can be dependent on each other or not, even though they are controlled and are connected to the same general process.

– in order to easily expand the system

The system's construction allows, where necessary, the easy extension or expansion of the network. Cable is added which thereby extends the production line without any additional controllers being installed.

How does the bus system AS-Interface work?

The AS-i system is distinguished by its special yellow profile cable. The cable connects all sensors, transducers and actuators on the network to a master system. The component parts of a system can include both non-safe and safe products. This means that both operational and safety related products can be mixed in a network. The bus system drives a Master-Slave (node) configuration where each I/O module corresponds to a common master.

Communication takes place through the yellow cable which also provides the nodes with supply voltage. The installation of the cable is usually done along a production line or centrally around the AS-i system's I/O products. After commissioning the system can always be expanded by adding branches or extensions to the cable. In a similar way, more products can be added, moved or replaced. The changes are easily made in the software to the controller. With the AS-i concept, decentralised systems can be designed with all products, non-safe and safe monitored by a device. This advantage means that the system can be handled as zones where one zone can be down, another can be in operation and a third manually operated. Without degrading operation and safety or influencing each other's zones.

Why is the AS-i Safety so good from a safety perspective?

The simple connection to a cable also applies to safety components. The risk of incorrect wiring is thereby minimised. Each safety node, i.e. safety product, has its own address on the AS-i bus along with a unique safety code.

The additional requirement for an AS-i system to cope with safety products is that there must be extra safe monitoring. The control ("Master") does not need to be safe, but is complemented with a safety Monitor (however, safety PLC Pluto AS-i can act as both Master and/or Monitor).

The advantage of safety within AS-i is that it is easy to introduce changes without significant costs compared to traditional safety systems that require new cable running from the electrical cabinet for each new protection. Moreover, experience shows that most safety systems need to be retrofitted to adapt the protection to suit the changes to production.

The AS-interface makes it easy to connect and remove products to and from the AS-i bus.

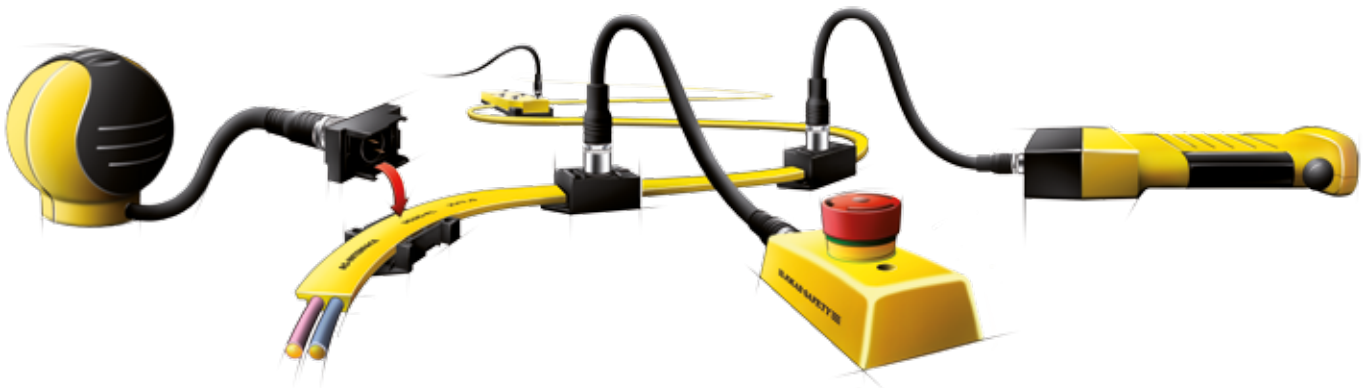

Voltage and communications

The AS-i network is maintained by a special AS-i power supply unit that generates a regulated DC output voltage between 29.5 and 31.6 V. This supplies voltage to the network nodes at the same time as communications are transmitted in a superimposed manner.

Nodes

Safety nodes (maximum 31) and A / B-nodes (maximum 62) are connected to the AS-i for both inputs and outputs.

Two-wire cable

The AS-i cable is a two-wire cable (2x1.5mm²) that is not shielded. Connection is made using piercing technology, where

the cable housing is self-restoring if a connection is moved. The cable retains enclosure protection class IP67 in this way.

Adaptation devices

For the AS-i cable it is possible to connect the adaptation devices that act as a link between a component and the AS-i system. These adaptation devices are available as both safety nodes and nodes for non-safe products.

Sensors with integrated safety nodes

Some AS-i adapted components have nodes directly built into the product, for example, there is one safety node in the customised Smile Emergency Stop.

Pluto AS-i

– Safety is now simple!

Pluto AS-i is a version of Pluto with AS-i bus connection. It can either be a master on the AS-i bus or work together with another AS-i master as a monitor. It has digital and analogue inputs and safe outputs. Pluto AS-i can also operate as a safe I/O module for the AS-i bus.

Safety level

Pluto, Urax and products with integrated safety nodes achieve safety level PL e/Cat. 4 in compliance with EN ISO 13849-1.

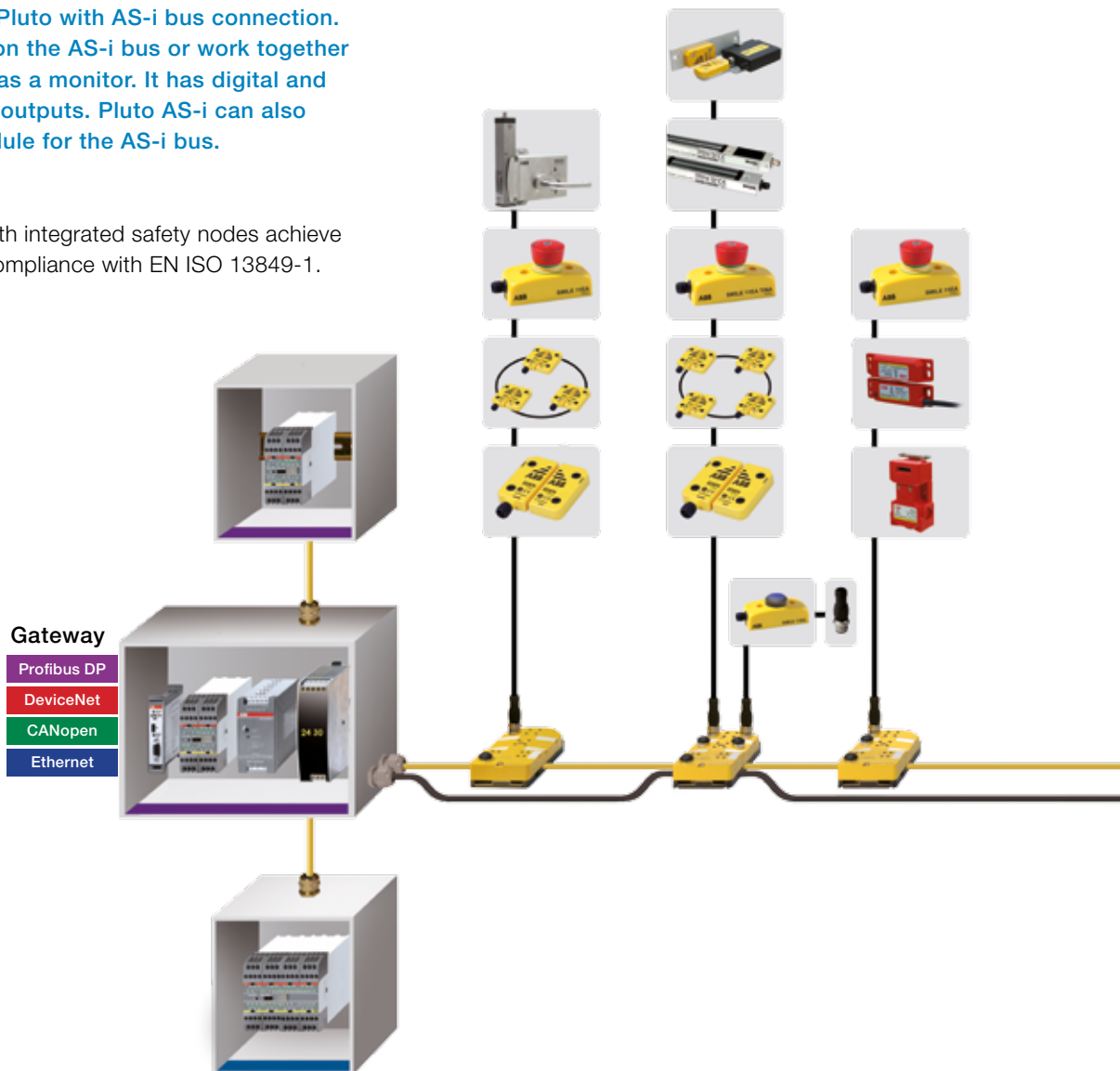

The AS-i system

The AS-i cable can be connected to the safety products separately or through the adaptation device Urax. Some components have an integrated AS-i node and are connected via an M12 connection directly to the yellow AS-i cable. Traditional products without an integrated AS-i node need to be connected via the safety node Urax.

In both cases, the highest level of safety is maintained. The AS-i cable is powered by 30 VDC power supply and connected to a special AS-i power supply unit. Some components have power requirements that are higher than the AS-i cable is able to supply. Therefore, there is also a black cable (AUX 24 VDC) with secondary supply voltage that is able to supply more current.

Adaptation device Urax with integrated safety node

Urax is an adaptation device for safety components that cannot be directly connected to the AS-i bus. You can connect safety components, local reset, and non-safe controls, such as process locks to Urax. Urax is available in several versions, adapted to suit specific safety products.

Possible connections for a complete system:

- all our sensors for AS-i via Urax
- all Pluto PLCs, gateways and absolute encoders through Pluto's safety bus to the Pluto AS-i
- operator panel via the programming port on Pluto
- expansion relay for multiple outputs

Simple connections to the AS-i cable

Adaptation devices are clamped directly to the AS-i cable. Transition from the AS-i cable to M12 units is made via a T connector on the AS-i cable. Cable branches or extensions of the AS-i cable are made using a splitter box.

Sensors with integrated AS-i safety nodes

Some of our products can be ordered with integrated AS-i node.

These are connected to the yellow cable with a M12 contact directly to the yellow AS-i cable via a screw terminal which is clamped to the cable. More information can be found under each product.

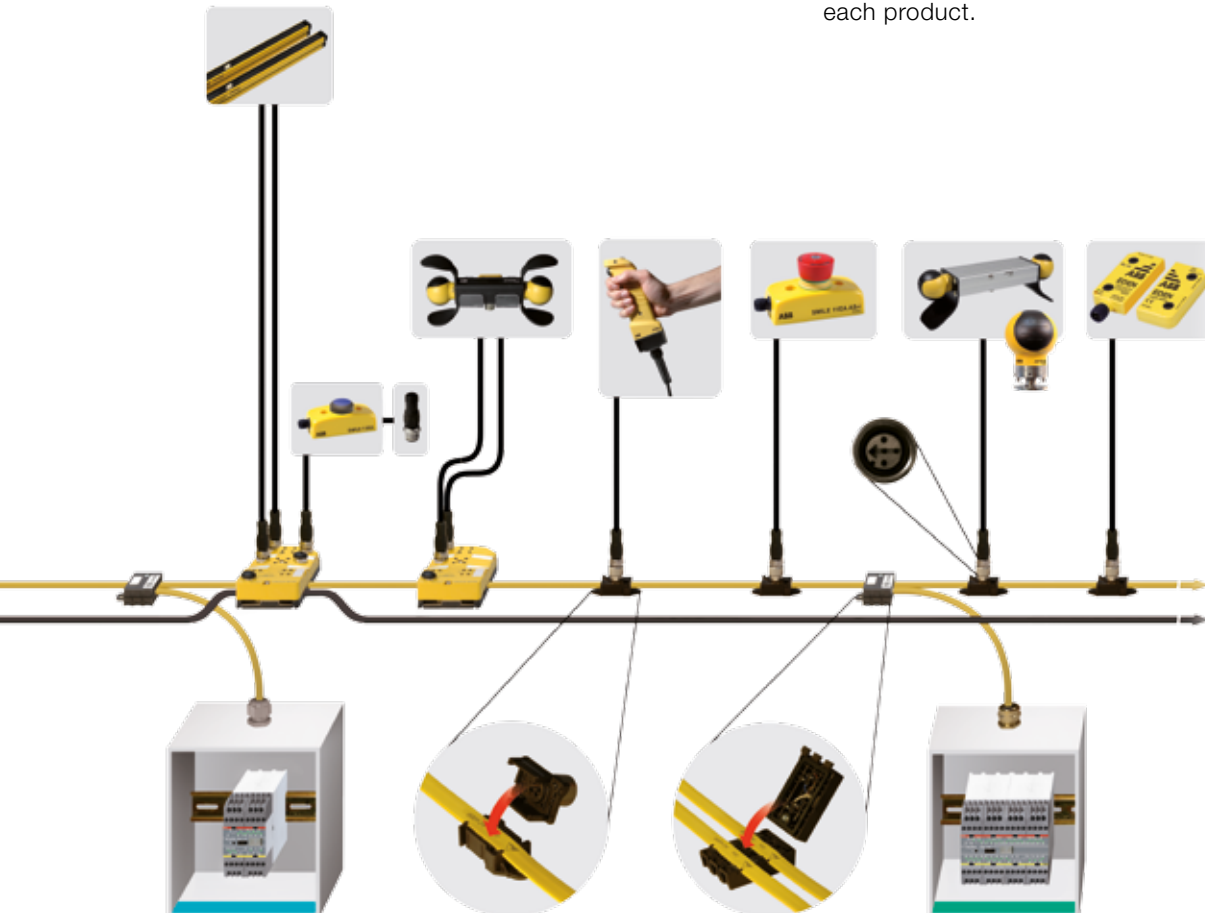

AS-interface - an intelligent cable running system

The field bus system AS-interface came to light in the 90s. The system was the result of a collaboration between several component manufacturers for machine control. The idea was a bus system at a component level where the goal was simplicity and flexibility. Since the system was launched, many new and innovative ideas have been added.

AS-International Association

In 1991, the AS-International Association for organisational cohesion and marketing was founded. The AS-i association works in both an advisory and auditing capacity to ensure the AS-i standard is maintained.

The goal of the AS-i Association is that the AS-interface is to become a world standard for easy communication for components within the automation industry.

The distinguishing feature of the AS-interface is that data communication is mixed with the power supply. This is done in a simple two-wire cable. In 2001 safety was integrated in the AS-interface via the work group Safety at Work, which also includes ABB Jokab Safety.

Pluto AS-i

A Pluto AS-i can be used in three ways - as Safety Master, Safety Monitor or as Safety I/O

1. Pluto as Safety Master*

The master distributes and controls communication on the AS-i bus and acts simultaneously as Safety Monitor.

2. Pluto as Safety Monitor*

The monitor listens to what is happening on the AS-i bus and controls the safe outputs.

3. Pluto as Safety I/O*

Multiple safe inputs and/or outputs are controlled and communicate with a safe master or monitor across the AS-i bus.

*Whether Pluto is used as a Master, Monitor or I/O it can simultaneously control and monitor the safety of a machine.

3

Gateway

Gateways allow you to communicate easily with other bus systems.

Bus connection

Pluto AS-i can be connected with other Pluto units both via the AS-i bus and through the Pluto safety bus.

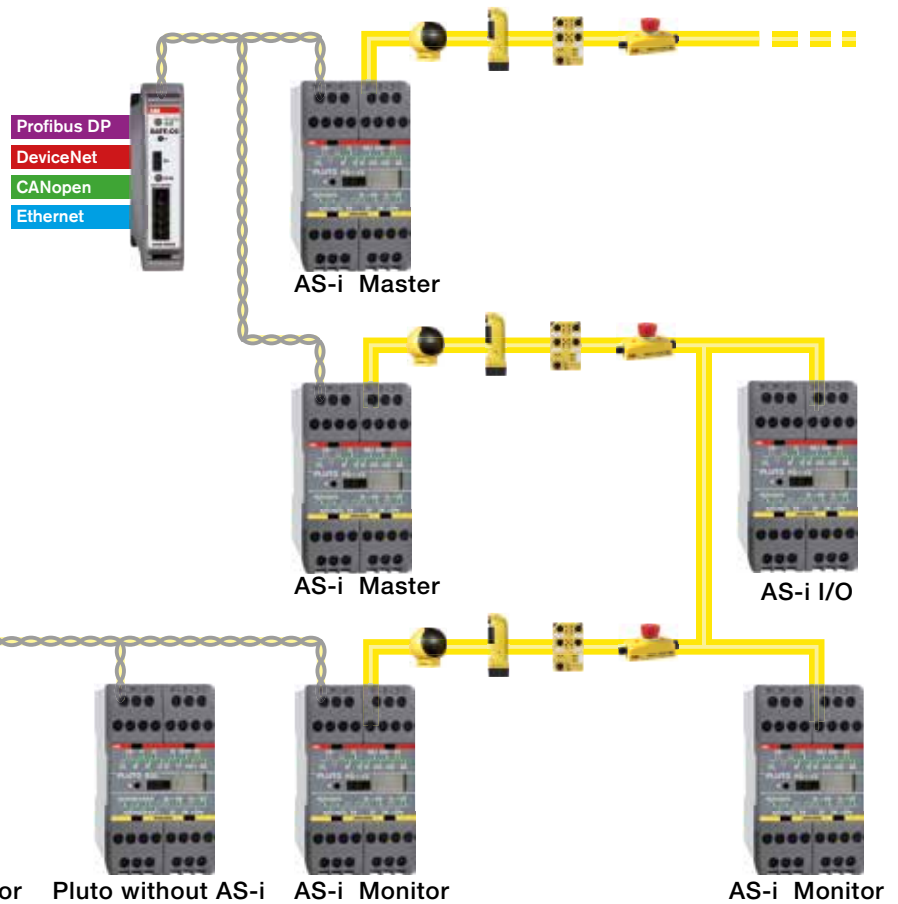

How large can you build the system?

From a technical aspect there are no constraints on the size of the system you can build. A Pluto PLC can, in addition to processing a complete AS-i bus, communicate with another Pluto either through a Pluto safety bus or through the AS-i bus.

Through Pluto's safety bus, each Pluto can be a party to the I/Os of others and a total of 32 Plutos can be linked in this way. If two Plutos are connected to each other via the AS-i bus, each Pluto can be connected to 31 other Plutos.

Using Gateways the system can be expanded further to other bus systems for information exchange.

Sensors with built-in AS-i safety nodes



Eden, a non-contact safety sensor with built in AS-i node

Eden is a non-contact safety sensor for use on interlocked gates, hatches etc. Eden consists of two complementary parts called Adam and Eva. The sensor is only activated if the gate or hatch is closed, when Adam and Eva are within sensing distance. Eden is constantly communicating between the two parts and any failure will directly lead to a stop signal



Safeball, a control device with a built-in AS-i node

Our globally-unique control device with ergonomic design fits all hands and offers many grip options. Safeball has double safety for each hand, i.e. two buttons on each ball need to be pressed. It can be used for either one or two hand operation.



Smile, a small and robust emergency stop with built in AS-i node

Smile has a width of 40 mm and its centered mounting holes make installation easy especially in aluminium profiles that are often used for machine construction and machine protection. Smile also has LED indication.



Three-position device with built in AS-i node

The three-position device JSHD4 with sensors that ensure that it is a human hand that grips the device (fraud-proof) is available with a built in AS-i node. The device is used for settings, fault tracking and test running when no other protection is possible or feasible.



The Urax safety node has safety inputs for sensors and reset buttons, and outputs such as process locks.

Urax safety node is available in several versions, and is designed for a variety of safety components. Urax has the capability to connect multiple sensors in series to the highest level of safety PL e in compliance with EN ISO 13849-1.

Model Urax	A1	A1R	B1R	C1	C1R	D1R	E1
Dynamic sensor (Eden, Tina)	3	3	10				
Two-channel sensors				●	●		
Sensors with OSSD Signals						●	
Two-hand station							●
Local reset function		●	●		●	●	
External power source			●			●	
Non-safe outputs	1	1	3			3	3

Safety node Urax-A1/A1R



Approvals:



Application:

- Adapts dynamic sensors to the AS-i bus

Features:

- Enables dynamic sensors on the AS-i bus
- Multiple sensors in series with maintained safety level
- Possibility of local reset
- Outputs of non-safe control, e.g. process locks

Adaptation device for dynamic sensors for AS-i.

Urax-A1/A1R is a safety node for the AS-i bus, where it is possible to connect up to three dynamic sensors, such as Eden, in series in compliance with PL e EN ISO 13849-1.

Switches adapted to dynamic sensors such as Smile Tina can also be connected to the safety circuit.

Urax-A1/A1R also has an output for non-safe control, where it is possible to control non-safety critical equipment such as process locks. Urax-A1R has an additional feature that provides local reset button (R) with LED indicator.

The dynamic safety sensors are controlled by Urax over one hundred times per second which gives a high level of safety.

Urax-A1/A1R has LED indication for the dynamic loop and can be addressed on the bus via the ADDR contact.



Connections for Urax-A1 and A1R

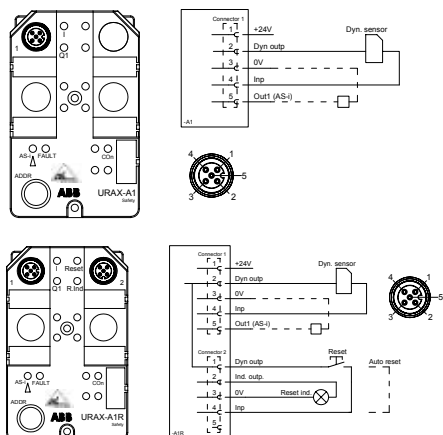

The concept of dynamic signal

The concept is a safety circuit that is based on a single-channel dynamic signal. The dynamic signal along with the adapted sensor makes it possible to build large systems with sensors in series while maintaining the highest level of safety. The safety principle is based on each sensor inverting the signal, making it possible to detect faults such as short circuits and defective sensors.

Odd or even number of sensors on Urax

The dynamic signal is generated in Urax and goes out to the sensors and then back again. The fact that the number of sensors may vary and that each sensor inverts the signal make it necessary for Urax-A1/A1R to be configured so that it takes into account whether it is an odd or even number of sensors that are connected to the safety loop. This is done via the AS-i node parameter settings.

Non-safe outputs

Urax-A1/A1R is fitted with a non-safe output. This can be used for diverse control or indicators and is controlled directly from the AS-i master.

The output is located on the same contact as the safety sensor, i.e. on contact 1 and controlled on pin 5. For example, you can connect a Dalton or Knox to this contact.

Reset

Urax-A1R has an input for local reset on contact 2 that can be configured using parameter settings for either automatic or manual reset.

Auto reset

If auto reset has been selected, pins 1-4 on contact 2 must be bridged.

Manual reset

If manual reset has been selected, the reset input must be switched on and off within 2 seconds in order for Urax to be enabled (generate safety code).

Technical data – Urax-A1/A1R

Article number	
Urax-A1	2TLA020072R0000
Urax-A1R	2TLA020072R0100
Colour	
	Yellow and black
Weight	
	155 g
AS-i data	
AS-i profile Urax-A1/A1R	S-7.B.E
Addressing	Jack plug
Slave address upon delivery	0
Voltage supply	
Voltage	AS-i yellow cable, 30 VDC. Tolerance 26.5 – 31.6 VDC.
Insulation	0 V is common with AS-i and must not be connected to the protective earth. (The AS-i voltage is floating.)
Total current consumption	<260 mA (Own consumption, sensor and outputs)
Current limit for the outputs in total	180 mA (Sensors, outputs and reset indicator)
Output (non-safe)	
Output voltage	24-28 VDC at nominal AS-i voltage, 30V.
Current	Depending on load. See total current consumption
Reaction time	
Reaction time (off)*	12 ms (excluding sensors and other peripheral components)
Reaction time including Eden sensor (Normal)	<20 ms
Reaction time including Eden sensor (Worst case)	<34 ms
Sensor info	
Number of Eden sensors (max)	3
Cable to sensor, total length	<30 m
Enclosure	
Enclosure protection class	IP67
Ambient temperature	-25...+65°C
Enclosure dimensions	96x60x25 (HxWxD)
Safety/Harmonised standards	
IEC/EN 61508-1..7	SIL3, PFD _{avr} : 1.5x10 ⁻⁴ , PFH: 1.7x10 ⁻⁹ , Share of SIL3: 15 %
EN 62061	SIL3
EN ISO 13849-1	PL e/Cat. 4
EN 954-1	MTTF _d : high
Certification	Cat. 4

*NOTE: The above reaction time refers only to the Urax device. In calculating the total reaction time, all the component parts in the safety chain must be taken into account.

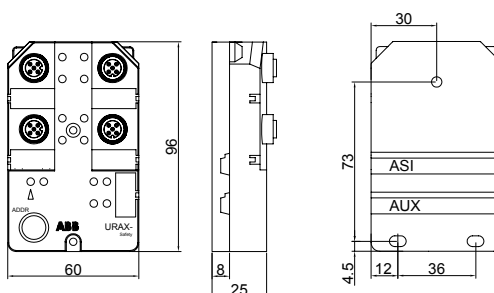

Safety node Urax-B1R

3



Approvals:



Application:

- Adapts dynamic sensors with higher current requirements to the AS-i bus

Features:

- Enables dynamic sensors on the AS-i bus
- Up to 10 sensors connected in series while maintaining the highest level of safety
- Possibility of local reset
- Outputs of non-safe control, e.g. process locks

Adaptation device for dynamic sensors for AS-i.

Urax-B1R is a safety node for the AS-i bus, where it is possible to connect up to ten dynamic sensors, such as Eden, in series in compliance with PL e EN ISO 13849-1.

Switches designed for dynamic safety circuit, such as Smile Tina, can also be connected.

Urax-B1R also has three outputs for non-safe control. Through these it is possible to control non-safety critical equipment such as the process lock Magne.

Urax-B1R will be supplied with an auxiliary power supply (AUX), which means that more power-consuming equipment can be connected to the node.

An additional feature is that it is possible to connect a local reset button (R) with LED indicator.

The dynamic safety sensors are controlled by Urax over one hundred times per second which gives a high level of safety.

Urax-B1R has LED indication for the dynamic loop and can be addressed on the bus via the ADDR contact.



Connections for Urax-B1R

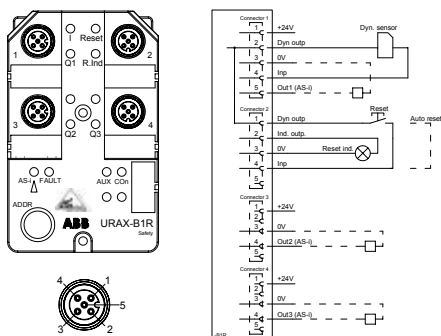

The concept of dynamic signal

The concept is a safety circuit that is based on a single-channel dynamic signal. The dynamic signal along with the adapted sensor makes it possible to build large systems with sensors in series while maintaining the highest level of safety. The safety principle is based on each sensor inverting the signal, making it possible to detect faults such as short circuits and defective sensors.

Odd or even number of sensors on Urax

The dynamic signal is generated in Urax and goes out to the sensors and then back again. The fact that the number of sensors may vary and that each sensor inverts the signal make it necessary for Urax-B1R to be configured so that it takes into account whether it is an odd or even number of sensors that are connected to the safety loop. This is done via the AS-i node parameter settings.

Non-safe outputs

Urax-B1R is fitted with three non-safe outputs. These can be used for diverse controls or indicators and are controlled directly from the AS-i master.

Output 1 is located on the same contact as the safety sensor, i.e. contact 1 and controlled on pin 5. For example, you can then connect a Dalton or Knox to this contact. Outputs 2 and 3 have non-safe control on pin 4 of contact 3 and 4 respectively.

Reset

Urax-B1R has an input for local reset on contact 2 that, with parameter settings, can be configured for either automatic or manual reset.

Auto reset

If auto reset has been selected, pins 1-4 on contact 2 must be bridged.

Manual reset

If manual reset has been selected, the reset input must be switched on and off within 2 seconds in order for Urax to be enabled (generate safety code).

Technical data – Urax-B1R

Article number	Urax-B1R	2TLA020072R0200
Colour		Yellow and black
Weight		155 g
AS-i data		
AS-i profile	Urax-B1R	S-7.B.E
Addressing		Jack plug
Slave address upon delivery		0
Voltage supply		
Voltage AS-i (Yellow cable)		30 VDC. Tolerance 26.5 – 31.6 VDC.
Voltage AUX (Black cable)		24 VDC (±15 %)
Insulation		0V is common with –AUX which shall be connected to protective earth at power supply.
Current limit (+24 V)		700 mA
Total current consumption AS-i		<30mA
Output (non-safe)		
Output voltage		24 VDC (AUX)
Current		700
Reaction time		
Reaction time (off)*		12 ms (excluding sensors and other peripheral components)
Reaction time including Eden sensor (Normal)		<20 ms
Reaction time including Eden sensor (Worst case)		<34 ms
Sensor info		
Number of Eden sensors (max)		10
Cable to sensor, total length		<30 m
Enclosure		
Enclosure protection class		IP67
Ambient temperature		–25...+65°C
Enclosure dimensions		96x60x25 (HxWxD)
Safety/Harmonised standards		
IEC/EN 61508-1..7		SIL3, PFD _{avr} : 1.5x10 ⁻⁴ , PFH: 1.7x10 ⁻⁹ , Share of SIL3: 15 %
EN 62061		SIL3
EN ISO 13849-1		PLe/Cat. 4
EN 954-1		MTTF _d : high
Certification		Cat. 4

*NOTE: The above reaction time refers only to the Urax device. In calculating the total reaction time, all the component parts in the safety chain must be taken into account.

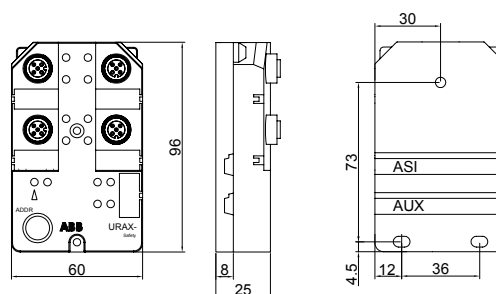

Safety node Urax-C1/C1R



Approvals:



Application:

- Adapts switches/E-stop with two-channel structure to the AS-i bus

Features:

- Suitable for both normally open (NO) and normally closed (NC) contacts
- Possibility of local reset

Adaptation device for sensors with two-channel structure on AS-i

Urax-C1/C1R is a safety node for the AS-i bus that enable the connection of switches or emergency stops. Connections can be made so that Urax-C1/C1R together with the switch comply with PL e EN ISO 13849-1.

Urax-C1/C1R is configurable depending on the switch you prefer to use. The safety node's two-channel structure works with both NO+NO and NO+NC contacts.

Urax-C1R has an additional feature that allows the connection of a local reset button (R) with LED indicator.

The safety switches' contacts are controlled by Urax each time they are actuated, for example when a door is opened and closed.

Urax-C1/C1R has LED indicators for all channels and can be addressed on the bus via the ADDR contact.

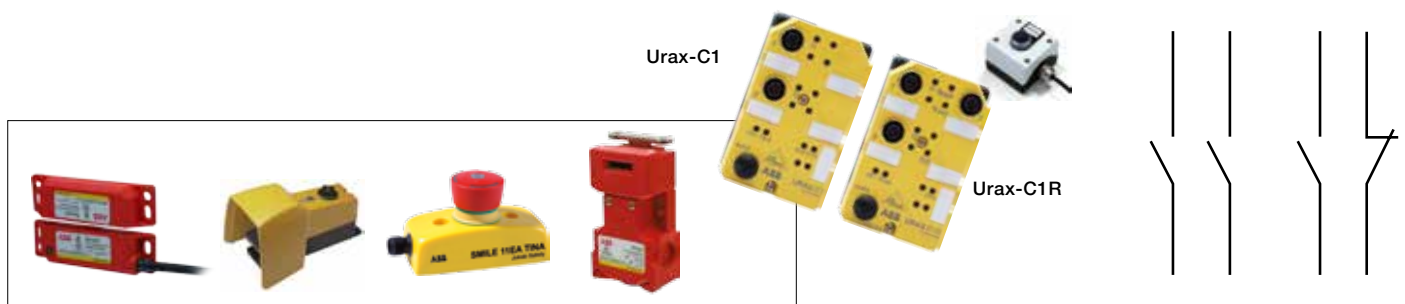

Connections for Urax-C1 and C1R

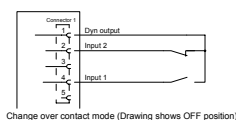
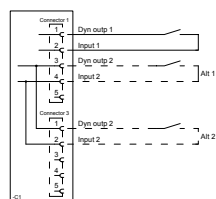
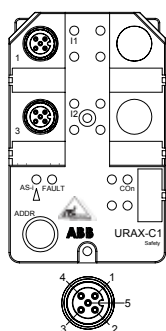

Change over contact mode (Drawing shows OFF position)

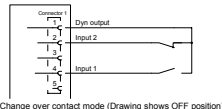
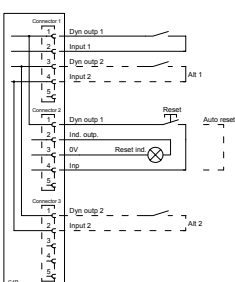
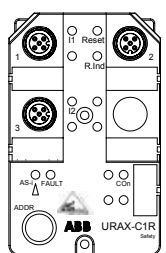

Change over contact mode (Drawing shows OFF position)

Two-channel input

Urax-C1 is designed for safety components with two-channel switches. The channels are supplied with individual dynamic signals which enables the detection of short circuits between channels. It is possible to either connect a two-channel component exclusively to contact 1, or to connect two separate single-channel components to contact 1 and contact 3.

Contact function, NO+NO/NO+NC

Urax-C1/C1R can work in either of the two operating modes NO + NO, with two closing contacts, or NO+NC with one closing and one opening contact. This selection is made using parameter settings.

Filtration of contact bounce

Urax-C1R has a function to filter contact bounce ("debounce") which is active irrespective of the parameter settings. After both channels (I1 and I2) have been enabled, it is accepted for 1 second that they turn off/on. In other words, the channel monitoring is disabled during the first second after being enabled.

Concurrency requirements

Urax-C1R also has the capability of monitoring concurrency requirements. Both channels must then change status within 2 seconds. This setting is made via the node's parametrisation.

Technical data – Urax-C1 and C1R

Article number	
Urax-C1	2TLA020072R0300
Urax-C1R	2TLA020072R0400
Colour	
	Yellow and black
Weight	
	150 g
AS-i data	
AS-i profile Urax-C1/C1R	S-0.B.0
Addressing	Jack plug
Slave address upon delivery	0
Voltage supply	
Voltage	AS-i yellow cable, 30 VDC (26.5 – 31.6)
Total current consumption AS-i	<150 mA
Reaction time	
Reaction time (off)*	12 ms (excluding sensors and other peripheral components)
Enclosure	
Enclosure protection class	IP67
Ambient temperature	-25...+65°C
Enclosure dimensions	96x60x25 (HxWxD)
Safety/Harmonised standards	
IEC/EN 61508-1..7	SIL3, PFD _{avr} : 1.5x10 ⁻⁴ , PFH: 1.7x10 ⁻⁹ , Share of SIL3: 15 %
EN 62061	SIL3
EN ISO 13849-1	PLe/Cat. 4
EN 954-1	MTTF _d : high
Certification	Cat. 4

*NOTE: The above reaction time refers only to the Urax device. In calculating the total reaction time, all the component parts in the safety chain must be taken into account.

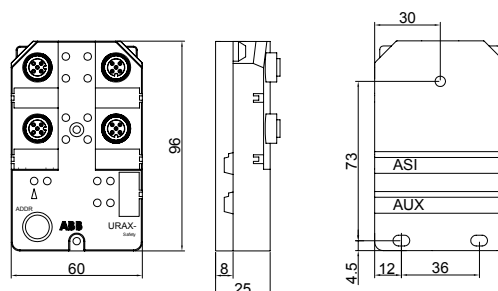

Reset

Urax-C1R has an input for local reset on contact 2 that can be configured using parameter settings for either automatic or manual reset.

Auto reset

If auto reset has been selected, pins 1-4 on contact 2 must be bridged.

Manual reset

If manual reset has been selected, the reset input switch must be switched on and off within 2 seconds in order for Urax to be enabled (generate safety code).

Safety node Urax-D1R

3



Approvals:



Application:

- Adapts safety products with transistor outputs (OSSD) to the AS-i bus

Features:

- Handles safety products with transistor outputs (OSSD)
- Monitors test pulses
- Possibility of local reset
- Outputs of non-safe control

Adaptation device for sensors with transistor outputs (OSSD) for the AS-i bus

Urax-D1R is a two-channel safety input slave for the AS-i bus that enables the connection of different protection with OSSD outputs. Examples of components of this type are light curtains, light grids and scanners. Connections can be made so that the safety node together with the sensor comply with PL e EN ISO 13849-1.

The safety node is also fitted with three non-safe outputs.

Urax-D1R has an additional feature that allows the connection of a local reset button (R) with LED indicator.

Urax-D1R has LED indicators for all OSSD outputs and can be addressed on the bus via the ADDR contact.



Connections for Urax-D1R

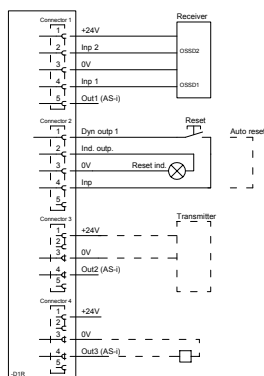
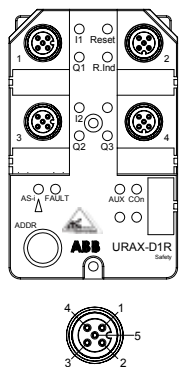

Monitoring of short circuits (test pulses)

The safety device that connects to Urax-D1R must be capable of detecting both short circuits between the channels and short circuits to the supply voltage. These types of faults are not detected by Urax! The most common way for the safety device to detect this is by transmitting test pulses on the outputs (OSSD).

Detection of test pulses

You can configure Urax-D1R to detect whether the test pulses are transmitted from the connected device or not (see Table, "Parameter settings and safety codes"). If Test Pulse Detection is selected, Urax will be disabled if these test pulses are missing. This feature is a safeguard against fraud.

Non-safe outputs

Urax-B1R is fitted with 3 non-safe outputs. These can be used for diverse controls or indicators and are controlled directly from the AS-i master.

Output 1 is located on the same contact as the safety sensor, i.e. contact 1 and controlled on pin 5. For example, you can then connect a Dalton or Knox to this contact. Outputs 2 and 3 have non-safe control on pin 4 of contact 3 and 4 respectively.

Reset

Urax-D1R has an input for local reset on contact 2 that, with parameter settings, can be configured for either automatic or manual reset. (See table, parameter settings and safety codes.)

Auto reset

If auto reset has been selected, pins 1-4 on contact 2 must be strapped.

Manual reset

If manual reset has been selected, the reset input must be switched on and off within 2 seconds in order for Urax to be enabled (generate safety code).

Technical data – Urax-D1R

Article number	Urax-D1R	2TLA020072R0500
Colour		Yellow and black
Weight		150 g
AS-i data	AS-i profile Urax-C1/C1R	S-0.B.0
Addressing		Jack plug
Slave address upon delivery		0
Voltage supply	Voltage AS-i (Yellow cable)	30 VDC. Tolerance 26.5 - 31.6 VDC.
	Voltage AUX (Black cable)	24 VDC (±15%)
	Insulation	0V is common with –AUX which shall be connected to protective earth at power supply.
Current limit (+24 V)		700 mA
Total current consumption AS-i		<30 mA
Output (non-safe)	Output voltage	24 VDC (AUX)
	Current	700
Reaction time	Reaction time (off)*	12 ms (excluding sensors and other peripheral components)
Enclosure	Enclosure protection class	IP67
	Ambient temperature	-25...+65°C
	Enclosure dimensions	96x60x25 (HxWxD)
Safety/Harmonised standards	IEC/EN 61508-1..7	SIL3, PFD _{avr} : 1.5x10 ⁻⁴ , PFH: 1.7x10 ⁻⁹ , Share of SIL3: 15 %
	EN 62061	SIL3
	EN ISO 13849-1	PLe/Cat. 4
	EN 954-1	MTTF _d : high

*NOTE: The above reaction time refers only to the Urax device. In calculating the total reaction time, all the component parts in the safety chain must be taken into account.

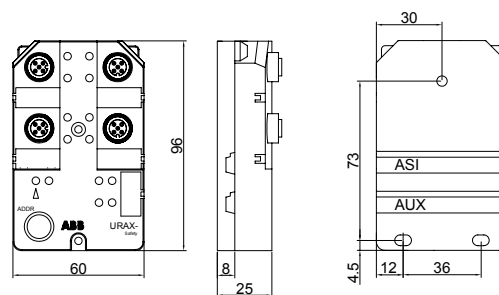

Safety node Urax-E1

3



Approvals:



Application:

- Adapts two-hand devices to the AS-i bus

Features:

- Handles two-hand devices with two channels
- Simultaneity requirement

Adaptation device for two-hand stations for the AS-i bus

Urax-E1 is a dual channel safety input slave to the AS-i bus, which is designed to connect the two-hand station in compliance with EN 574 model IIIC. Connections can be made so that the safety node with two-hand station complies with PL e EN ISO 13849-1.

Urax-E1 has LED indicators for all channels and can be addressed on the bus via the ADDR contact.

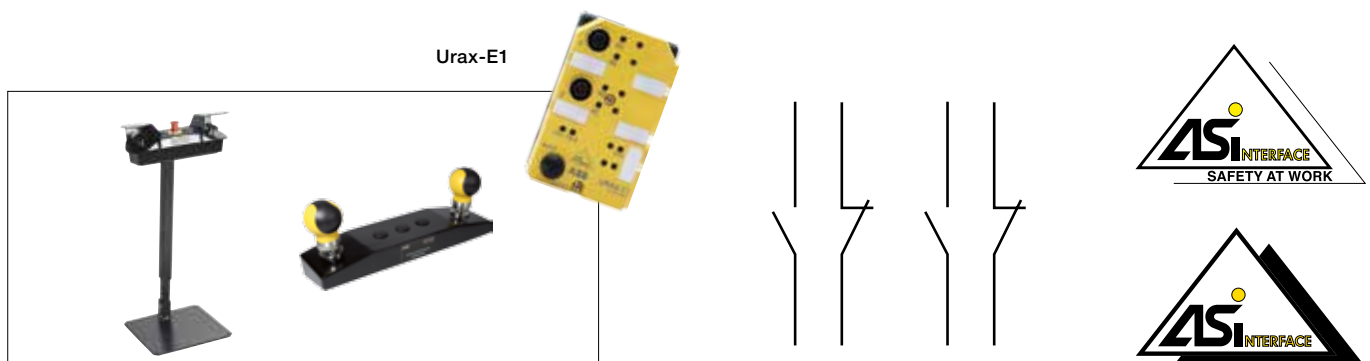

Connections for Urax-E1

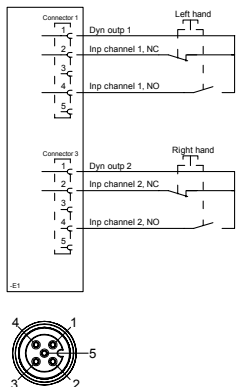
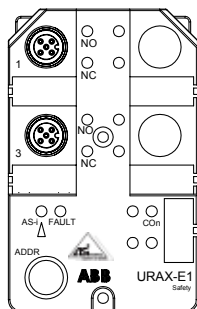

Inputs for two-hand stations

Urax-E1 has two inputs for each hand, one for closing and one for opening contact. For safe activation (generating safety code), all four inputs are required to be enabled within 0.5 seconds. All inputs are monitored, and if Urax is disabled (stops generating safety code) this requires that all four inputs are disabled before a restart is possible. ("Open" condition for a opening (NC) contact is closed contact, and "Open" condition for a closing (NO) contact is open contact.)

Technical data – Urax-E1

Article number	Urax-E1	2TLA020072R0600
Colour		Yellow and black
Weight		150 g
AS-i data	AS-i profile Urax-C1/C1R	S-0.B.0
Addressing		Jack contact
Slave address upon delivery		0
Voltage supply	Voltage	AS-i yellow cable, 30 V DC (26.5 – 31.6)
Total current consumption AS-i		<150 mA
Output (non-safe)	Output voltage	24V DC (AUX)
Current		700
Reaction time	Reaction time (off)*	12 ms (excluding sensors and other peripheral components)
Enclosure	Enclosure protection class	IP67
Ambient temperature		-25...+65°C
Enclosure dimensions		96x60x25 (HxWxD)
Safety/Harmonised standards	IEC/EN 61508-1..7	SIL3, PFD _{avr} : 1.5x10 ⁻⁴ , PFH: 1.7x10 ⁻⁹ , Share of SIL3: 15 %
EN 62061		SIL3
EN ISO 13849-1		PLe/Cat. 4
EN 954-1		MTTF _{gt} : high
Certification		Cat. 4

*NOTE: The above reaction time refers only to the Urax device. In calculating the total reaction time, all the component parts in the safety chain must be taken into account.

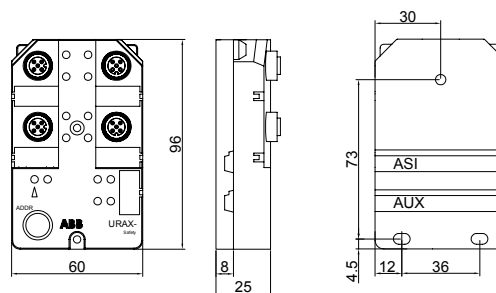

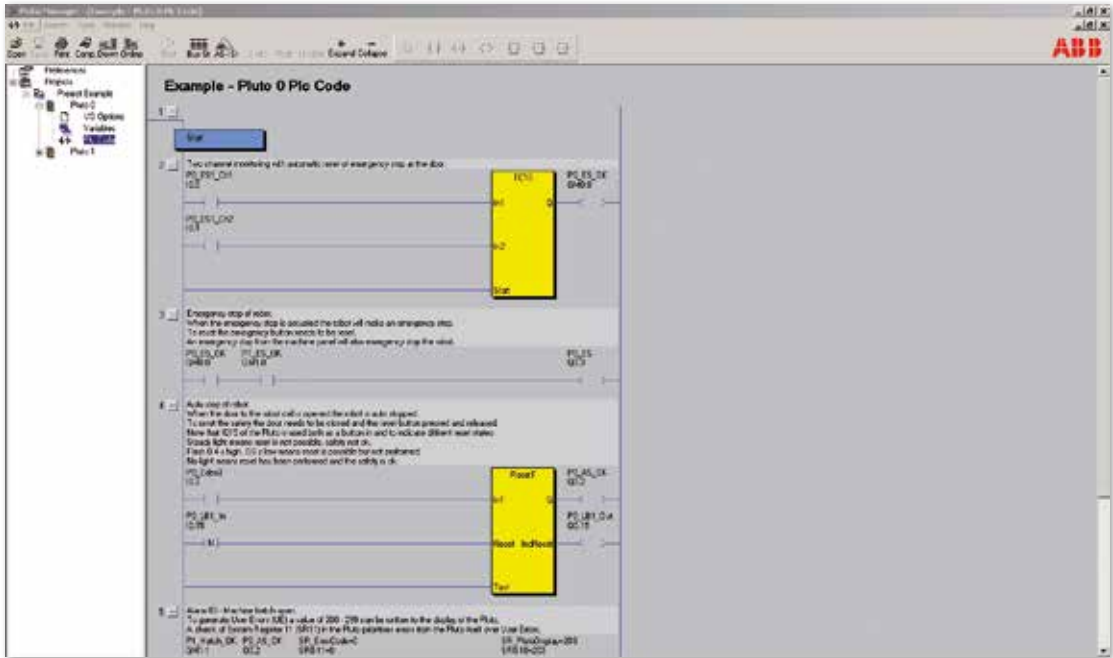

Pluto Manager

Programming tool Pluto Manager

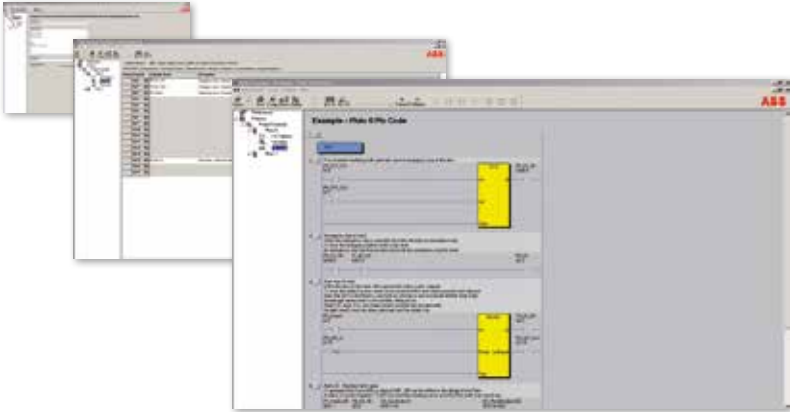

4

Use:

- Gates
- Hatches

Features:

- Free software
- Downloaded from www.abb.com/jokabsafety
- Ready to use function blocks for your safety components
- Contains TÜV-approved function blocks
- Provides an overview of the current projects and your Plutos
- Easy programming through ladder language

A programming tool for your safety functions

Pluto Manager is a software tailored for the safety PLC Pluto. Programming is done in ladder and together with the function block creates the structure of your safety functions. The software comes with predefined function blocks approved by TÜV to facilitate the work on designing the safety functions. Pluto Manager offers the possibility to split the program into different program blocks in order to separate various program functions from each other, and it gives you a structured overview of Plutos, gateways and peripheral components in large and small projects. It gives you an overview and control of the sensors and actuators, and the reactions between them. Pluto Manager also contains manuals for the software and hardware that are connected and needs to be handled through the program. The interface gives the option to connect to one of the Plutos in the net, and go online and view the status for Pluto's two bus options, AS-i and Pluto bus. There are also diagnostic functions and the option to export data.

Systematic working method through project management

Step 1 - Configuration of I/O

In every started project, each Pluto is defined individually. Its inputs and outputs are configured as desired and depending on what they connect to. Pluto's IQ ports are also configured here as inputs or outputs, dynamic or static signals.

Step 2 - Naming of variables

After configuration the systems variables are determined. Inputs (I), outputs (Q), remanent memories (M), global auxiliary memories for bus communication (GM) and registers (R) are given names that can be used in place of the actual variable designation in the PLC program.

Step 3 - Ladder programming

The program is built using the named variables connected to inputs and outputs. The programming language has a full range of instructions, similar to standard PLCs on the market, with timers, arithmetic, sequence programming etc.

The project is then downloaded to Pluto via a programming cable. This program is distributed simultaneously through bus communication to the other Plutos in the project. In this way, you need only access a single Pluto where each Pluto gets the right information specified in your project.

Pluto Manager is included when purchasing the safety PLC Pluto. The software is Windows based and can be downloaded free from www.abb.com/jokabsafety.

List of standard and special function blocks for Pluto Manager

The safety designer has complete freedom to program the safety functions or to use TÜV-approved pre-defined safety function blocks.

Standard library “func05”:

- 6 different blocks for two-channel function. (With or without start input, test input, reset input, output for two-channel fault, monitoring of simultaneous operation.)
- 3 different blocks for single-channel function. (With output for reset button indication, with or without start input, test input.)
- 2 different blocks two-channel function with time limitation.
- Block for single-channel preset.
- Block for two-channel preset.
- 4 different blocks for muting (bypass).
- Block for two-hand control.
- 2 Counter blocks (up-count and down-count).
- 4 different blocks for muting lamp. (Pluto A20 only.)
- Block for off-delay function.
- 2 Blocks for light curtains.
- Block for multiplication.

- Block for division.
- Block for monitoring of selector switch.
- 2 blocks for validation of exported register value sent over bus. (For register or for double registers.)

Library “AS-i01”:

- Blocks for Pluto AS-i and B42 AS-i. (Control of, and reading of AS-i slaves, AS-i locks etc.)

Library “Ext01”:

- Blocks for communication with external devices (gateways, HMI etc.)

Library “Analog01”:

- Blocks for reading of analogue inputs. (Pluto D20 and D45 only.)

Library “Counter01”:

- Blocks for speed monitoring via counter inputs. (Pluto D45 only.)

Library “Encoder01”:

- Blocks for absolute encoders.

Special function blocks:

- Program library with blocks for eccentric shaft presses.

Example: Function block TC2RTI

Two-channel function with test, reset inputs and reset indication.

- In1 and In2 are safety inputs, to which the safety device outputs are connected.
- Test is an input condition which must be true at the start up moment and can be used for monitoring of external components. Test must switch on before In1 and In2, i.e. the function block cannot be initiated by Test.
- Reset is a monitored reset input which must switch on-off (reset on negative edge) after all other inputs, in order to switch on the output of the function block.
- IndReset is an output for indication which is ON when the function block is switched off and In1, In2 or Test is off, and flashes when the function block is ready for activation with reset.
- TCfault is on at two-channel fault, i.e. when the function block is on, and only one of In1 or In2 switches off and on again.



Description

The function block works as a conventional safety relay with redundant and monitored inputs (In1, In2).

Example: Function block Twohand1

Two-hand control for actuators with NO/NC + NO/NC contacts.

- Right_NO is right hand NO contact
- Right_NC is right hand NC contact, etc.
- Test is an input condition that must be on before any of the other inputs changes from the initial position and can be used for monitoring of external components.

Function:

- In initial position shall:
- Right_NO be off,
- Right_NC be on,
- Left_NO be off and
- Left_NC be on

To start the output (Q), these four inputs must change state in 0.5 seconds and remain in that position. After stop, all inputs must come to the initial position to enable restart.

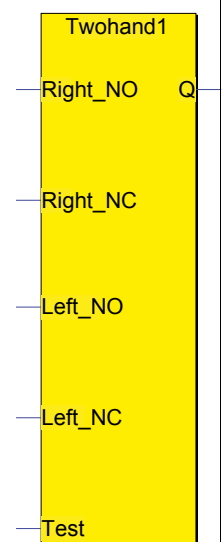



Safety system - Vital

Supervision of dynamic safety signals

Safety system - Dynamic safety circuit - Vital-Tina 5/3

Safety Controller - Vital

Why should you use the Vital safety system? 5/5

How does a dynamic circuit of Vital work? 5/6

Safety Controller - Vital 5/7

Adaptation unit - Tina

Why should you use the Tina adaptation units? 5/21

Tina is available in several versions 5/22

Tina 1A 5/23

Tina 2A/B 5/24

Tina 3A/APS 5/25

Tina 4A 5/26

Tina 5A 5/27

Tina 6A 5/29

Tina 7A 5/30

Tina 8A 5/31

Tina 10A/B/C 5/33

Tina 11A 5/35

Tina 12A 5/36

Accessories 5/37

Example of safety sensors connections based on 'Y' branch 5/38

Connection examples 5/40

Safety system

Dynamic safety circuit – Vital and Tina

Vital is a safety controller with a dynamic safety circuit that can monitor up to 30 sensors, such as Eden, in accordance with the highest safety level. Vital has selectable manual or automatic resetting and dual outputs. (The Pluto safety PLC has many inputs for dynamic safety circuits.)

Each active sensor and Tina unit has LEDs that indicate OK (green), broken safety circuit (red) or flashing if the loop has been broken by another earlier sensor.

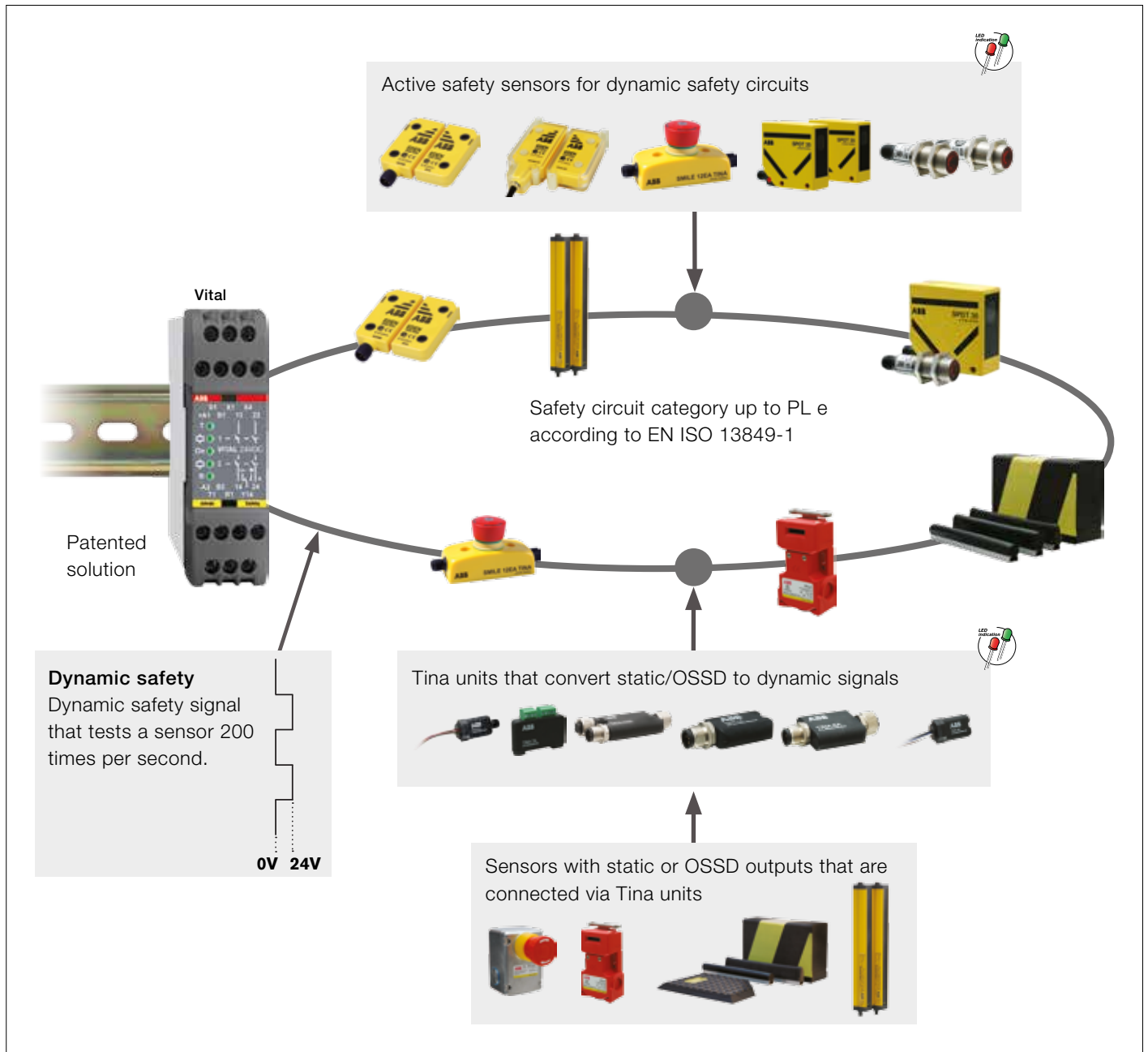

Vital is available in three versions

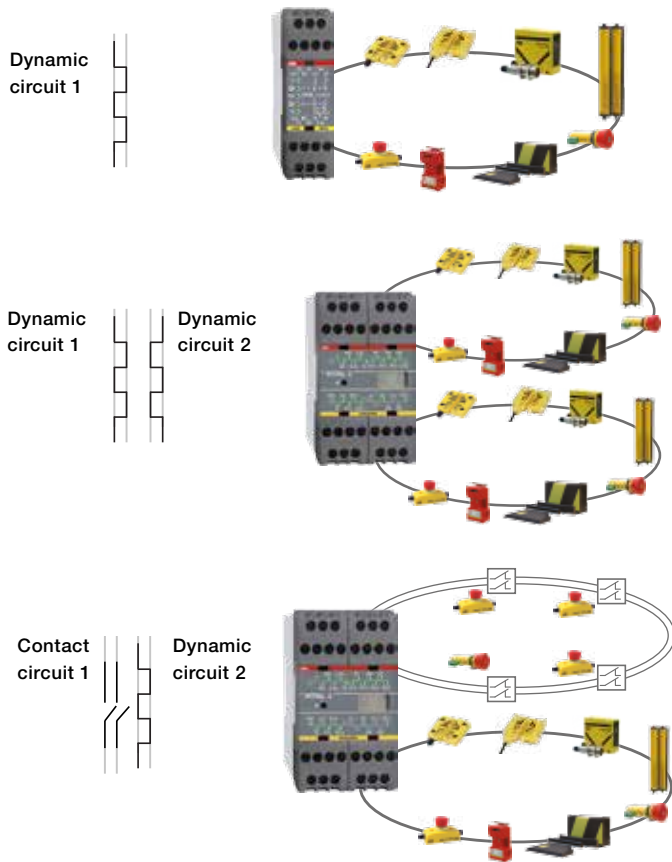

Vital 1

- Up to 30 sensors can be connected to the same dynamic safety circuit

Vital 2

- Two safety circuits are monitored by one module
- Simple system with extensive functionality
- Up to 10 sensors can be connected to each dynamic safety circuit
- Output group 2 can be set for time delay
- Three different modes of operation

Vital 3

- Two safety circuits are monitored by one module
- Devices with two-channel, opening contacts can be connected to one circuit
- Simple system with extensive functionality
- Output group 2 can be set for time delay
- Three different modes of operation

One Vital supervises the entire robot cell!

This example shows a cell that consists of dynamic protection sensors connected to a Vital with the following functions:

Two charging stations

At each charging station a light curtain checks for anyone putting their hand into a risk area, and an Eden sensor checks whether a robot is inside the same risk area. This means that a stop is only ordered if a robot and a person are in the same area. When the station is clear, the person presses the reset button connected to the light curtain.

Fence with Eden-interlocked door

If the door is opened, the robot stops. To reset the robot system, the door must be closed and a supervisory reset button operated.

Three emergency stops with Tina units

If any of the emergency stop buttons is pressed, the robot performs an immediate emergency stop.

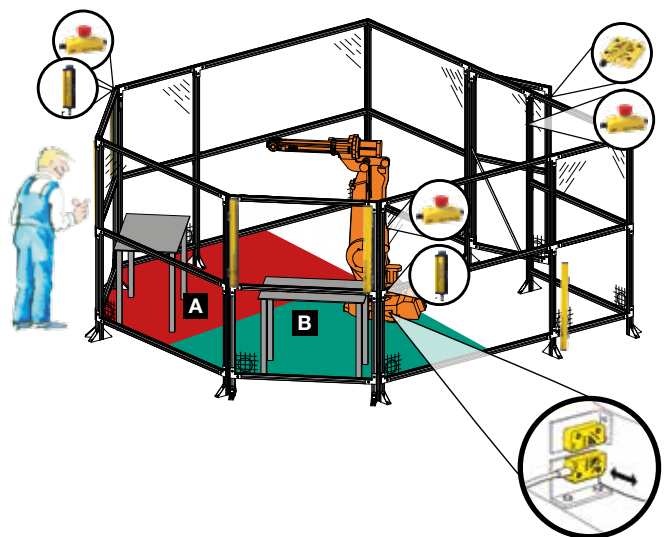

Why should you use the Vital safety system?



5

– to be able to connect several safety components in series (up to PL e, cat. 4) and supervise them with only one safety controller!

Vital is the heart of a solution which makes it possible to install/connect many different types of safety device in the same safety circuit and still achieve PL e according to EN ISO 13849-1. The Vital module is based upon a dynamic single-channel concept as opposed to conventional dual-channel safety relays. Up to 30 dynamic sensors can be connected directly in the safety circuit and be supervised by only one Vital module. The Vital therefore replaces several safety relays. Safety components with output contacts can be connected to the Vital via low cost Tina adaptors.

The Vital also has automatically or manually supervised reset selection, dual safety outputs, and an information output for reset indication and status information for PLC's.

– to supervise safety components!

Most safety components on the market can be connected to the Vital module. Dynamic sensors enable safety PL e to be achieved in a single-channel system. For example ABB Jokab Safety's dynamic non-contact Eden sensor, Spot light beam and emergency stops (via Tina adaptors) can be used. Even mechanical switches can be connected to Vital with the aid of ABB Jokab Safety's Tina adaptors.

– for easy installation and assembly of a safety system!

Vital is a small electronic safety controller that dynamically supervises a number of safety components. Vital's detachable connector blocks simplify the connection, trouble-shooting and exchange of modules. The Vital and other safety components can be connected together using standard cables and with cables having M12 connections.

Reasons to choose Vital

- PL e, according to EN ISO 13849-1 dynamic safety circuit
- Can accommodate long cable lengths
- Manually supervised or automatic reset
- Two NO safety outputs
- Detachable connector blocks
- LED indication of: power supply, dynamic signal and outputs
- Information output with two functions
- Cost-effective cable routing/connections

How does a dynamic circuit of Vital work?

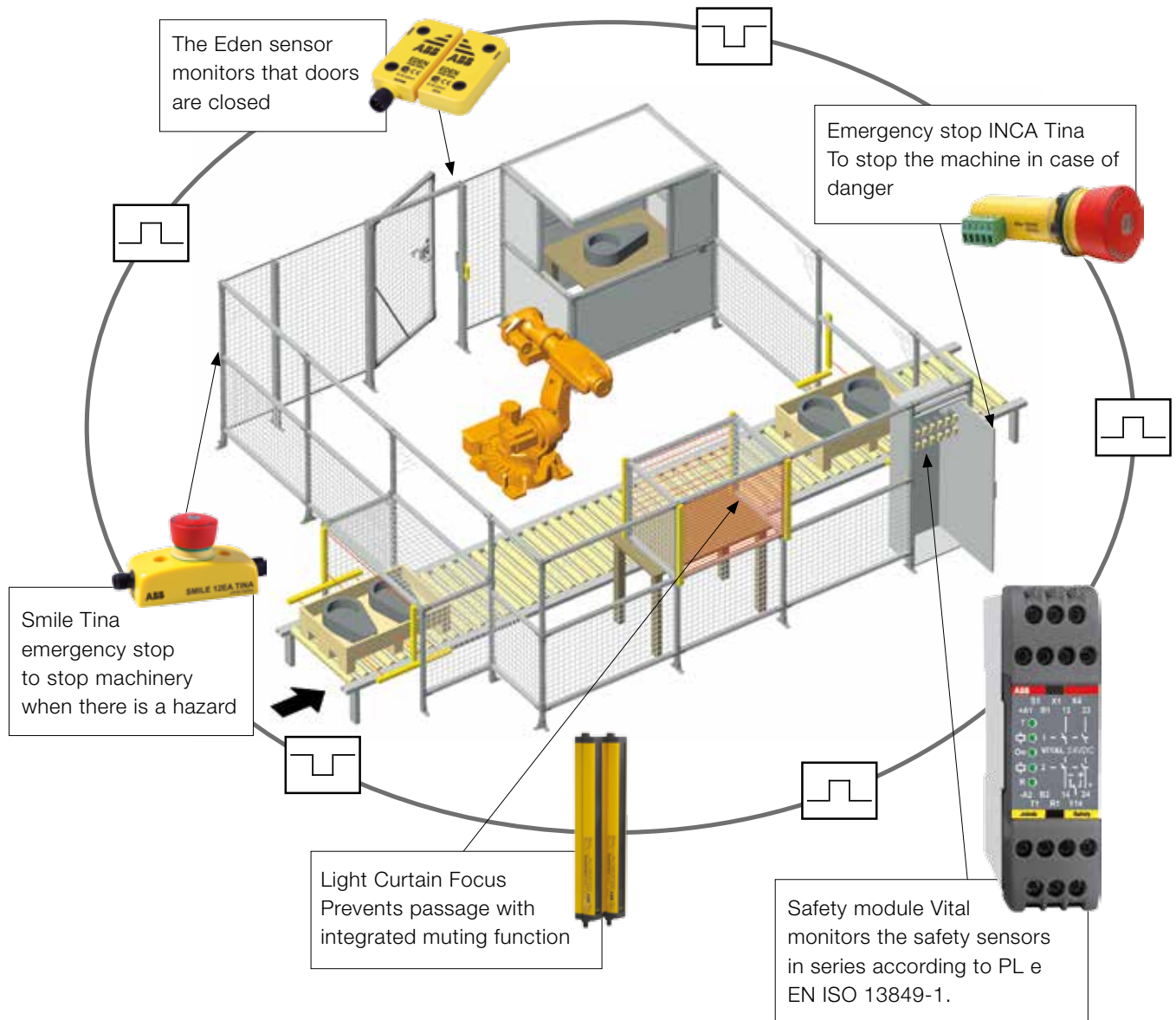

The dynamic signal consists of a square wave that is transmitted through the safety circuit. The signal is inverted at each safety component and is monitored 200 times per second by Vital or Pluto.

The dynamic signal is transmitted as single channel throughout all the protection in the same safety circuit between input terminals T1 and R1. If a protection breaks, the dynamic signal is not transmitted which is detected by Vital which breaks its safe outputs. Even short circuits across a protection are detected when the signal is inverted in each sensor (the

protection is then OK), while Vital expects a correctly inverted signal at the right time. In this case, an even number of sensors are connected to the safety loop which means that the dynamic signal will be inverted an even number of times when it is evaluated by Vital. This is determined by the terminal inputs S1 and B1 being connected together. If an odd number of sensors have been connected, connection of S1 is not required. As the signal is evaluated by Vital at each pulse, i.e. more than 200 times per second, faults and short circuits are detected within a few milliseconds.

Safety controller Vital



Approvals:

TÜV Nord – Vital 1
TÜV Rheinland – Vital 2 and 3



Application:

- Entire safety system based on the dynamic safety circuit.

Features:

- Easy installation
- Flexible
- Cost effective
- Display for troubleshooting (Vital 2 and 3)
- A wide range of safety sensors can be connected into the circuit
- Several safe outputs
- Information output
- Outputs with time delay (Vital 2 and 3)

Vital is based on a single channel safety concept where multiple safety sensors can be connected in series and monitored with a single safety controller. A dynamic signal is sent from Vital through all connected sensors, and then returned to Vital which then evaluates the received signal. As each safety sensor inverts the signal, it is possible to detect short circuits or faults in any of the sensors. Vital is designed for use with ABB Jokab Safety Eden sensors, Tina components and Spot light grids or similar products. Vital 2 and 3 are both safety controllers with two safe input functions and two output groups, the only difference between the two models being in the input configuration.

Vital 1 Safety controller

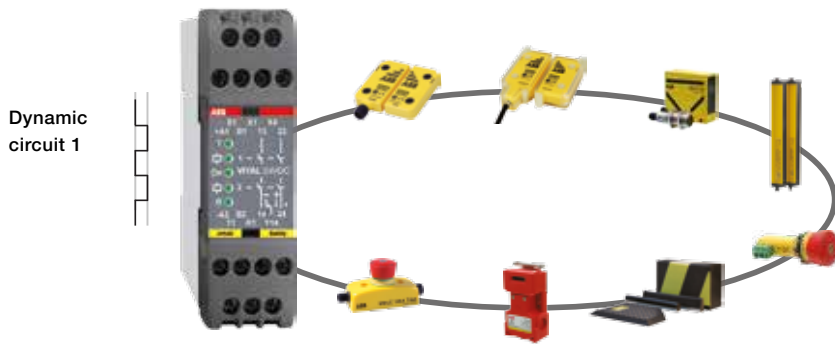

- Up to 30 sensors can be connected to the same dynamic safety circuit

Vital 2 Safety controller

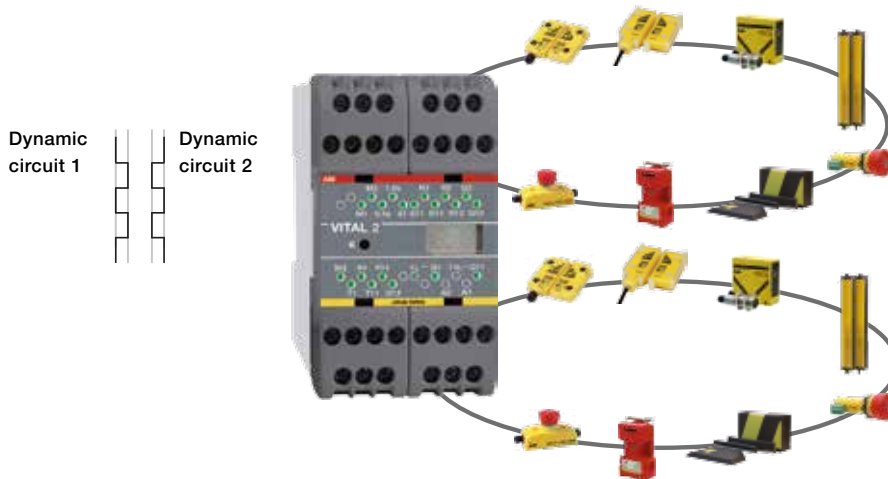

- Two safety circuits are monitored by one module
- Simple system with extensive functionality
- Up to 10 sensors can be connected to each dynamic safety circuit
- Output group 2 can be set for time delay
- Three different modes of operation

Vital 3 Safety controller

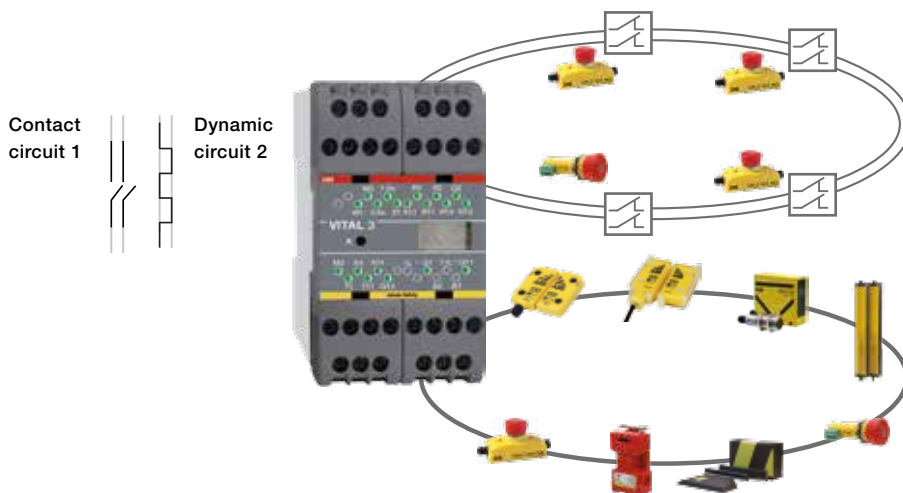

- Two safety circuits are monitored by one module
- Devices with two-channel, opening contacts can be connected to one circuit
- Simple system with extensive functionality
- Output group 2 can be set for time delay
- Three different modes of operation

Reset connections – Vital 1

Manually supervised reset

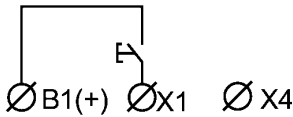

The manually supervised reset contact connected to input X1 must be closed and opened in order to activate the relay outputs.

Automatic reset

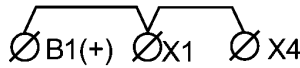

Automatic reset is selected when B1, X1 and X4 are connected. The relay outputs are then activated at the same time as the inputs.

Testing external contactor status

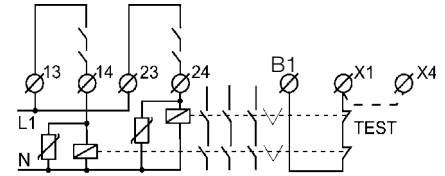

Contactors, relays and valves can be supervised by connecting 'test' contacts between B1 and X1. Both manually supervised and automatic reset can be used.

5

Output connections – Vital 1

Relay outputs

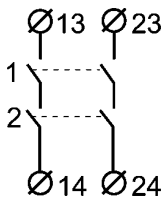

The Vital 1 has two (2 NO) safety outputs. In order to protect the output contacts it is recommended that loads (inductive) are suppressed by fitting correctly chosen VDR's, diodes etc. Diodes are the best arc suppressors, but will increase the switch-off time of the load.

Connection of S1

Even number of units in series (Eden+Spot+Tina) requires a connection between B1 and S1. S1 is not connected at odd number of units. See drawing below figure A and other examples in the book

Information outputs

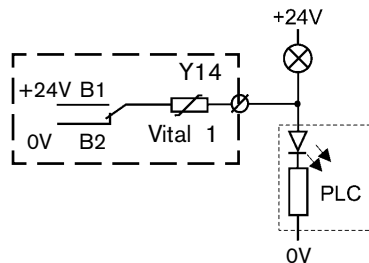

Vital 1 has a switching relay output for information. The function is determined by a DIP switch.

The DIP switch position 1 (original position) is the information output Y14 internally connected to 0V and +24 V as per:

- Y14 is closed to 0V (B2) internally when Vital 1 has not been reset.
- Y14 is closed to +24 V (B1) when Vital 1 has been reset.

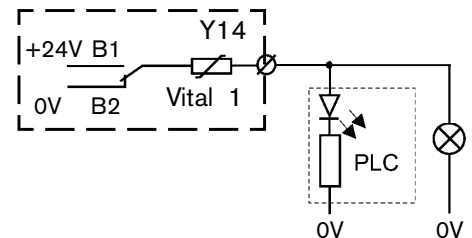

In DIP switch position 2 (the purpose of the function is to start/restart block, RES) the information output Y14 is internally connected to 0V and +24 V as per:

- Y14 is internally closed to 0V (B2) when the dynamic safety loop is open or when the dynamic safety loop is closed and Vital 1 has been reset.
- Y14 is internally closed to +24 V (B1) when the dynamic safety loop is closed but Vital 1 has not been reset (RES).

Technical data – Vital 1

Article number	Vital 1	2TLA020052R0000
Level of safety	EN ISO 13849-1	PL e/Cat. 4
	EN 62061	SIL 3
	IEC/EN 61508-1...7	SIL 3
PFH_D		2.74×10 ⁻⁸
Colour		Grey
Weight		220 g
Power supply	Vital, A1-A2	24 VDC ±15%
	From Vital to sensors/units, B1-B2	24 VDC
Fuse	An external fuse should be fitted in the supply to A1	3 AT
Max line resistance	at nominal voltage to X1	150 Ohm
Power consumption	DC supply, nominal voltage (without load)	3 W
	DC supply, nominal voltage (with max load)	48 W
Dynamic safety circuit	T 1	Output signal
	R 1	Input signal
Reset input X1	Supply for reset input	+24 VDC
	Reset current	30 mA max. (inrush current 300 mA during contact closure)
	Minimum contact closure time for reset	150 ms
Connection of S1	Even numbers of sensors (Eden + Spot T/R + Tina) require a connection between B1 and S1. S1 is not connected for odd numbers of sensors. Odd number, no connection between B1 and S1.	
Number of sensors	Max. number of Eden/Tina to Vital 1	30
	Total max. cable length to Eden/Tina	1000 m
	Max. number of Spot T/R to Vital 1	Up to 6 pairs
	Total max. cable length to Spot T/R	600 m
Maximum number of units varies depending on the installation and cable size. For more information, see the examples in this chapter.		
Response time	At Power on	< 65 ms
	When activating (input-output)	< 40 ms
	When deactivating (input-output)	< 48 ms
	At Power loss	< 55 ms
Relay outputs	NO	2
	Max switching capacity, resistive load	6A/250 VAC/1500 VA/150W
	Minimum load	10 mA/10V
	Contact material	AgCdO
	Mechanical life	>10 ⁷ operations
	External fuse (EN 60947-5-1)	6.3A or 4A slow

Relay information output (changeover contact)	Y14	-(0V)	Indicates Vital is not reset
		+(24V)	Indicates Vital is reset
	Max. load on Y14		200 mA (Internal automatic fuse)
LED indication	On	●	Fixed light: supply voltage OK, Flashing light: under-voltage or overload.
	T	●	T: Signal out OK.
	R	●	R: Signal in OK.
	☐	● 1	Indicates that the output relays have been activated
	☐	● 2	
Mounting	DIN rail		35 mm DIN rail
	Operating temperature range		-10°C to + 55°C
Connection blocks (detachable)	Max screw torque		1 Nm
	Max connection area:		
	Solid conductors		1x4 mm ² / 2x1,5 mm ² / 12AWG
	Conductor with socket contact		1x2,5 mm ² / 2x1 mm ²
	Air and creep distance		4kV/2 DIN VDE 0110
Protection class	Enclosure		IP40 IEC 60529
	Connection blocks		IP20 IEC 60529
Conformity	EN ISO 12100-1, -2, EN 954-1, EN ISO 13849-1, EN 62061, EN 60204-1, IEC 60664-1, EN 61000-6-2, EN 61000-6-4 EN 60947-5-1, EN 1088, EN 61496-1, IEC/EN 61508-1...7		

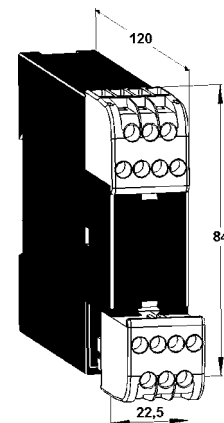

Connector blocks are detachable (without cables having to be disconnected)

Connection examples of safety devices to Vital 1

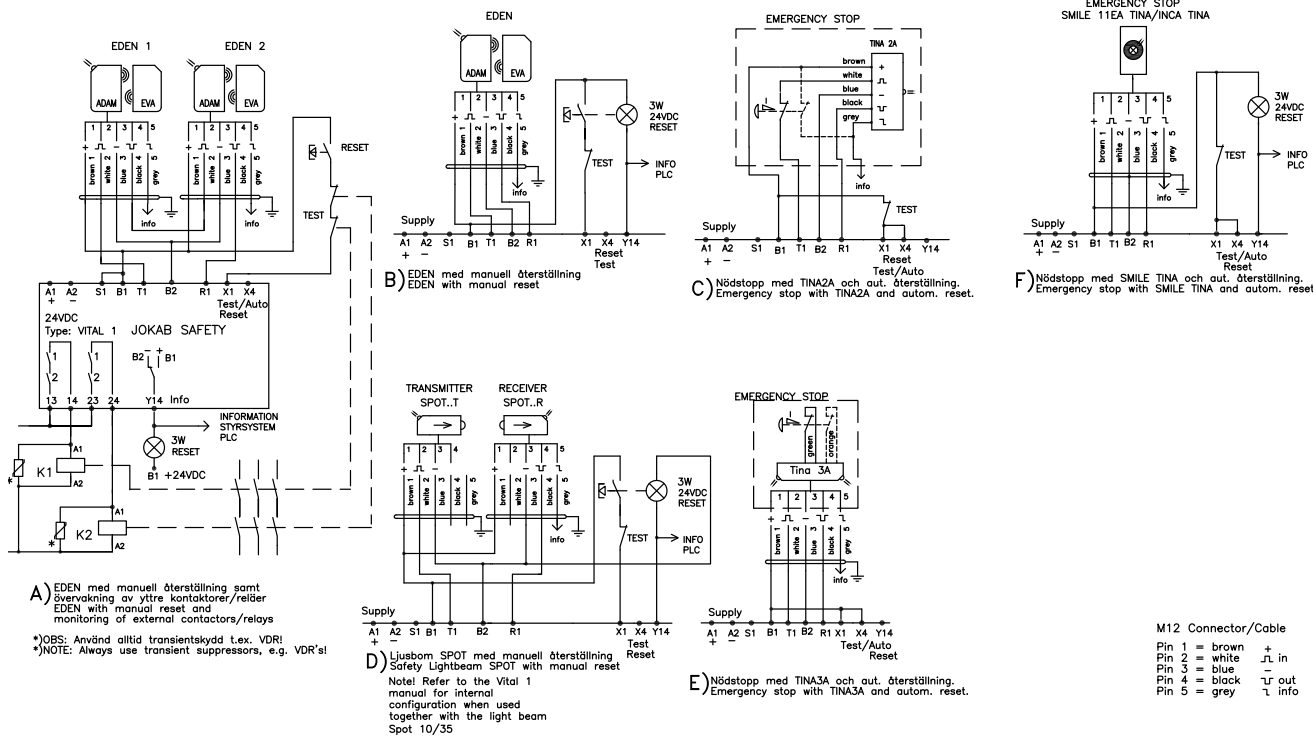

Connection of units and cable lengths to Vital 1

CONNECTION EXAMPLE VITAL1 SOLUTIONS

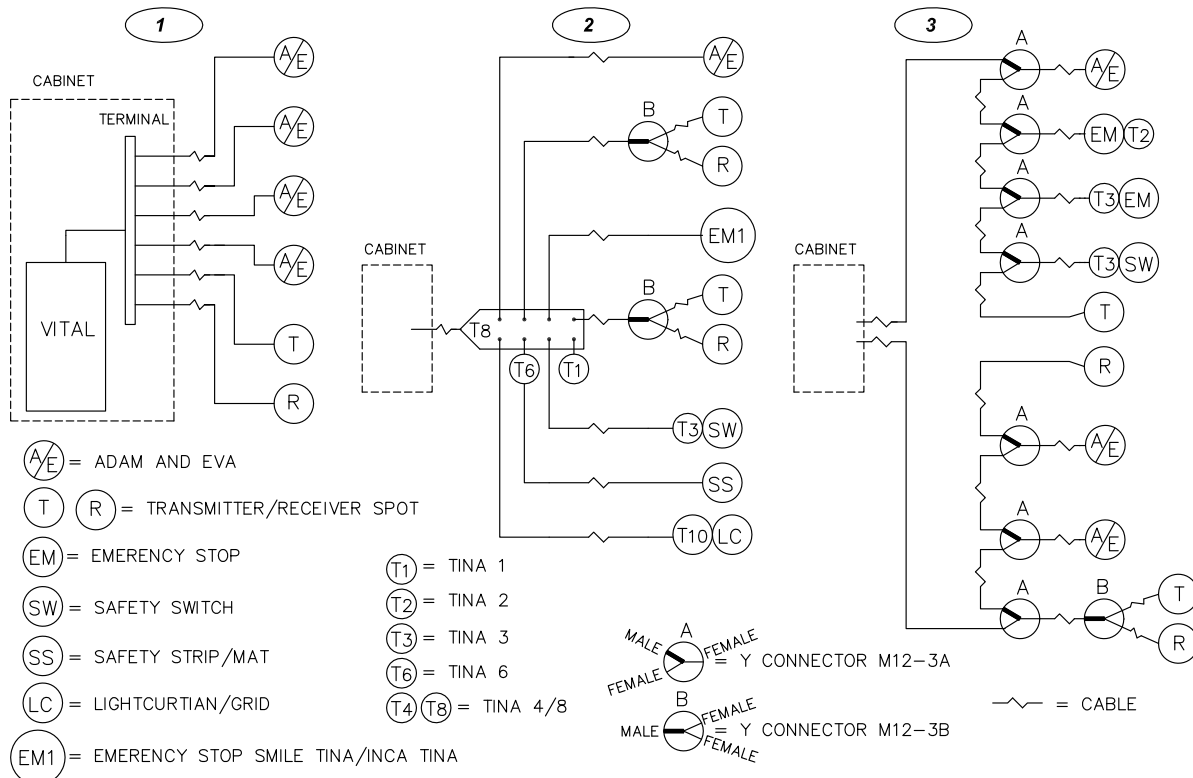

INFORMATION IS AVAILABLE VIA CABLE FROM EACH SENSOR IN EX. **1** AND **2**

HH3400A2

Three connection alternatives

According to PL e (EN ISO 13849-1), connection of sensors/adaptor units in the Vital safety circuit must be made as the connection examples.

Example 1

Use separate connection cables from each sensor/adaptor unit to the Vital safety controller. Interconnections to be made via suitable terminals in the control cabinet.

Example 2

Use Tina4A/Tina8A connector blocks to simplify the connection of externally mounted sensors/adaptor units. Only Tina4A/Tina8A connector blocks may be used. Use of any other connector blocks will not meet the safety circuit requirements.

Example 3

Use M12-3A and M12-3B 'Y' connectors to connect sensors in series/parallel.

Cable lengths and number of sensor/adaptor units for the three connection examples.

In order to determine the number of sensor/adaptor units that can be connected to a Vital 1 unit it must be remembered that 1 (one) Spot T/R is equivalent to 5 (five) Eden or Tina units. Units in parallel are equal to one unit. The following examples provide guidance as to possible configurations and cable lengths using suitable cables.

Example 1

Up to 1000 metres (0.75 mm² or 0.34 mm² conductors) in total can be connected to the sensors/units in this example. The connection is equivalent to 9 Eden or Tina units.

A maximum of 30 Eden or Tina units can be connected to the Vital 1 unit on a maximum cable length of 500 metres (0.75 mm² conductors) or 300 metres (0.34 mm² conductors).

Example 2

Up to 600 metres (0.75 mm² conductors) to Tina 8A and 10 metre cables type M12-C1012 (0.34 mm²) to each sensor/unit connected to the Tina 8A. This connection example is equivalent to 17 Eden or Tina units.

A maximum of 3 Tina 8A units, equivalent to 27 Eden/Tina units (= 3 x 8 connected to Tina 8A + 3 Tina 8A) can be connected to one Vital 1 with a total cable length of 600 metres (0.75 mm²). Up to 6 Tina 4A units can be connected to one Vital 1 (equivalent to 30 Eden/Tina units) with a total cable length of 600 metres (0.75 mm²) to Tina 4A.

Example 3

Either 2 x 500 metre cables (0.75 mm²) from the control cabinet and 10 metre cables (0.34 mm²) to each sensor/unit or 2 x 10 metre cables (0.75 mm²) from the control cabinet and 200 metre cables (0.75 mm²) to each sensor/unit. The connection is equivalent to 16 Eden or Tina units.

A Total of 30 Eden/Tina units can be connected using a maximum cable length of 1000 metres (0.75 mm²) or 400 metres (0.34 mm²). If the power supply is only fed from one direction (from one end of the network) the total cable length is reduced to approx 300 metres (0.75 mm²) and 100 metres (0.34 mm²).

Connection advice for dynamic sensors to Pluto and Vital.

Sensors can be connected in many different ways. Here is some advice that can make connection better and more stable. The advice is general, but particularly applicable to the use of Tina 4A and Tina 8A units.

- Never have more than the recommended number of sensors in the loop.
- If possible use a switched mains power supply that can deliver a stable 24 VDC.
- In the sensor system, use as short cables as possible.
- When connecting a Tina 4A or Tina 8A unit, the supply voltage at the terminal (out at the unit) must not be less than 20 Volts.
- Use screened cable, preferably 0.75 mm² or thicker, from the apparatus enclosure and ground it at one end, for example at the apparatus enclosure, not at both ends.
- Do not route the signal wiring close to heavy current cabling or close to equipment that gives off a lot of interference, such as frequency converters for electric motors.
- Never connect "spare" conductors.
- If M12-3B are used for connection of a parallel loop, with supply to the sensors from two directions, the loop must be as short as possible. This is because the conductors that are not being used are also connected, which increases the capacitive load and reduces the stability of the system.

Operating mode M1 - Separate function Vital 2

Input function 1 controls output group 1, and input function 2 controls output group 2.

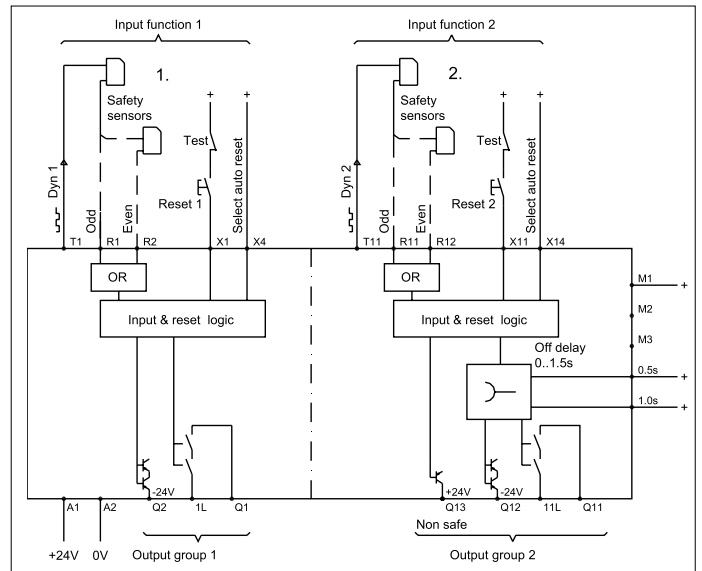

5

Operating mode M2 - Input 1, master function Vital 2

Input function 1 stops all outputs, and input function 2 stops output group 2.

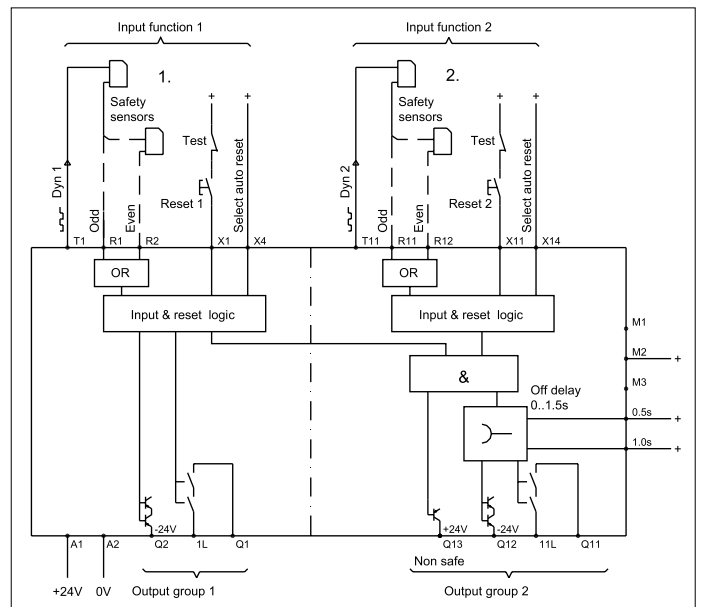

Operating mode M3 - Parallel function Vital 2

Input function 1 and input function 2 operate in parallel and control all outputs. Reset/Auto reset 1 resets both input functions (Reset/Auto Reset 2 is not used).

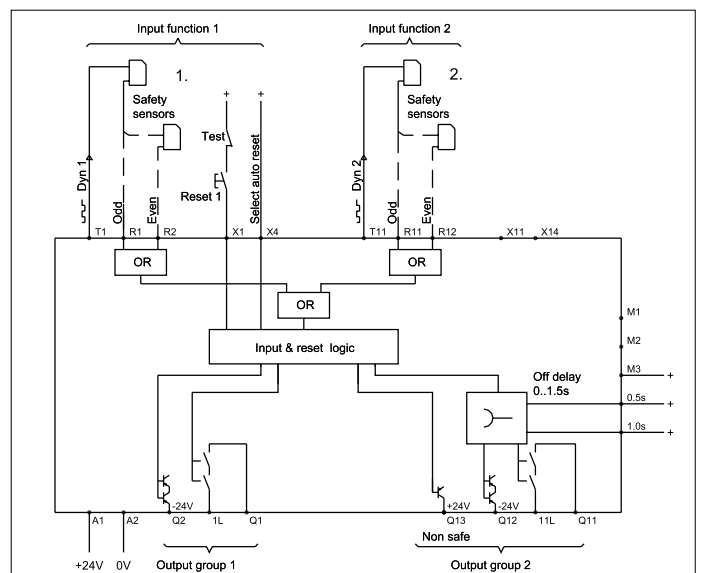

Connection of protection/sensors - Vital 2

Depending on the input function and the number of sensors connected to the safety circuit (odd or even number), the dynamic signal is connected between different terminals;

Input function 1

A dynamic signal is transmitted from T1, and depending on the number of sensors in the safety circuit, the signal connects back to R1 (odd number of sensors) or R2 (even number of sensors).

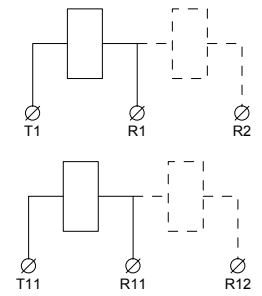

Input function 2

A dynamic signal is transmitted from T11, and depending on the number of sensors in the safety circuit, the signal connects back to R11 (odd number of sensors) or R12 (even number of sensors).

Connection of outputs - Vital 2

Connection of safe transistor output (-24 V)

The safe transistor outputs Q2 (output group 1) and Q12 (output group 2) have an output voltage of -24 V.

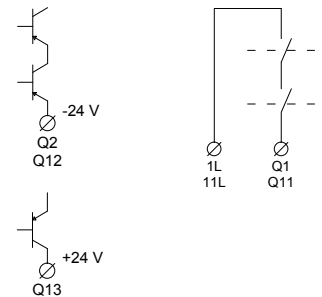

Connection of safe relay output

The safe relay outputs that are duplicated in series break between 1L-Q1 (output group 1) and 11L-Q11 (output group 2). The loads that break should be fitted with spark arresters to protect the outputs. The correct selection of VDR circuit, RC circuit or diode is appropriate. Note that the diode extends the disconnection time of the load.

Connection of information output

The non-safe transistor output Q13 is high (+24 V) when the outputs from output group 2 are active. The function is therefore dependent on the operating mode selected (see Selection of operating mode).

5

Connection of reset - Vital 2

There are two separate reset functions; Reset 1 and Reset 2. The function of these is dependent on the operating mode selected (see Selection of operating mode). Reset 1 and Reset 2 can be configured for manual or automatic reset independently of each other by means of the input's Auto reset 1 and Auto reset 2.

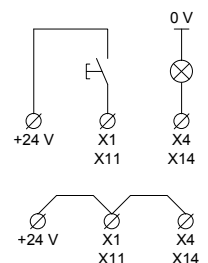

Manual monitored reset

For manual resetting, a push button must be connected between X1 (Reset 1) or X11 (Reset 2) and +24 V. The monitoring contacts for external devices are to be connected in series with the push button. For manual reset, X4 (for Reset 1) and X14 (for Reset 2) serve as output for resetting the indicator lamps.

Automatic reset

For automatic reset, X1 and X4 (Auto reset 1) or X11 and X14 (Auto reset 2) must be connected to +24 V. Monitoring contacts for external devices must be connected between +24 V and X1 (Auto reset 1) or X11 (Auto reset 2). If monitoring contacts are not used, X1 and X11 must be connected to +24 V.

Time delay - Vital 2

Output group 2 can have disconnection delay by connecting inputs 0.5s and 1.0s being connected to +24 V. The system is binary, which means that the time values of the inputs are added together to give the total delay time.



Technical data – Vital 2

Article number	2TLA020070R4300
Level of safety	
EN ISO 13849-1	PL e/Cat. 4
EN 62061	SIL 3
IEC/EN 61508-1...7	SIL 3
EN 954-1	Cat. 4
PFH ₀	
Relay output	2.00 × 10 ⁻⁹
Transistor output	1.50 × 10 ⁻⁹
Colour	Grey
Weight	390 g
Power supply	24 VDC ±15%
Fuse	
An external fuse must be connected in series with the supply voltage to A1	6 A
Max line resistance at nominal voltage to X1	150 Ohm
Power consumption	
Total current consumption	300 mA
Input function 1 (dynamic safety circuit)	
Dynamic output signal	T1
Dynamic input signal	R1 (odd number of sensors in a circuit) R2 (even number of sensors in a circuit)
Input function 2 (dynamic safety circuit)	
Dynamic output signal	T11
Dynamic input signal	R11 (odd number of sensors in a circuit) R12 (even number of sensors in a circuit)
Reset input X1/X11	
Voltage at X1/X11 when reset	+24 VDC
Reset current	30 mA (300 mA peak during contact closure)
Minimum contact closure time for reset	80 ms
Number of sensors	
Max. number of Eden or Tina units per input function	10
Total max. cable length (depending on the number of Eden/Tina units)	500 m
Max. number of light beams (Spot T/R) per input function	
Spot 10	1
Spot 35	3
Total max. cable length (depending on the number of Spot T/R)	100 m
Maximum number of units varies depending on the installation and cable size. For more information, see the examples in this chapter.	
Response time	
Relay output (Q1, Q11)	15 – 24 ms
Safe transistor outputs (Q2, Q12)	11 – 20 ms

Non-safe transistor output (Q2, Q12)	11 – 20 ms
Relay outputs	
Number of outputs	2 NO
Max. load capacity, res. load	6A/250 VAC
Max. load capacity, ind. load	AC-12: 250 V/1,5 A AC-15: 250 V/1,5 A DC-12: 50 V/1,5 A DC-13: 24 V/1,5 A
Safe transistor outputs	
Number of outputs	2
Output voltage (rated)	-24V
Output voltage (at load)	> 22V at 800 mA/24V supply voltage 23.3V at 150 mA/24V supply voltage
Max. load	800 mA
Short circuit protection	
Output – 0V	Yes
Output – +24V	Normal (not guaranteed)
Non-safe transistor output (information)	
Output voltage (rated)	+24 VDC
Max. load	1 A
Mounting	
DIN rail	35 mm DIN rail
Operating temperature range	-10°C to + 55°C
Connection blocks (detachable)	
Max screw torque	1 Nm
Max connection area:	
Solid conductors	1x4 mm ² / 2x1,5 mm ² / 12AWG
Conductor with socket contact	1x2.5 mm ² / 2x1 mm ²
Air and creep distance	4kV/2 DIN VDE 0110
Protection class	
Enclosure	IP40 IEC 60529
Connection blocks	IP20 IEC 60529
Approved standards	EN ISO 13849-1/EN 954-1, EN ISO 13849-2, EN 62061, EN 61496-1, EN 574, EN 692, EN 60204-1, EN 50178, EN 61000-6-2, EN 61000-6-4, EN 61000-4-, IEC/EN 61508-1...7

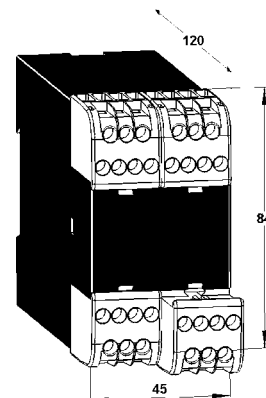

Connector blocks are detachable (without cables having to be disconnected)

Vital 3

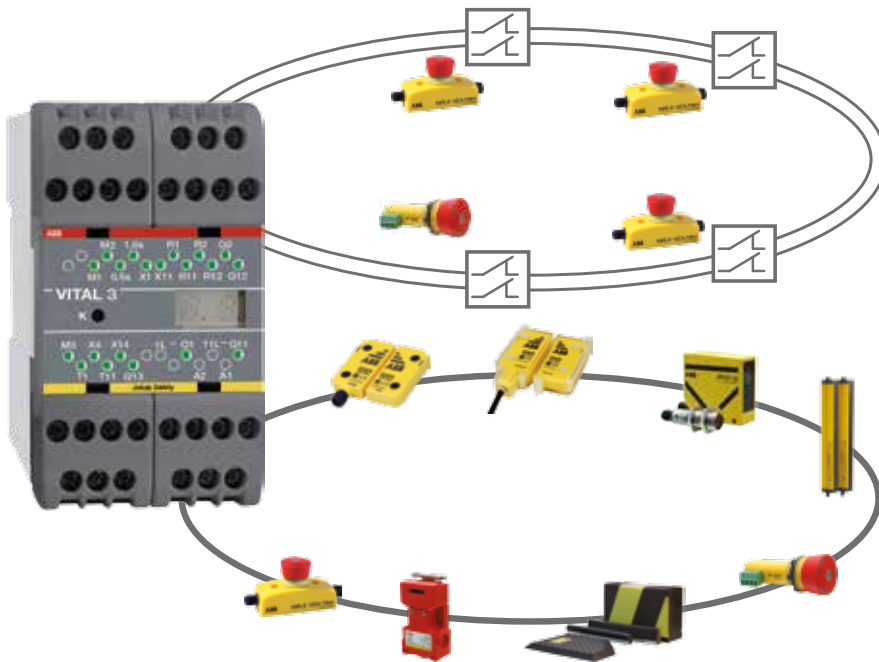

Vital 3 is a safety controller that combines functionality with the quick and easy installation of safety sensors. With two safe input functions and two different output groups, Vital 3 offers the capability to exclusively control smaller machine safety systems that would otherwise have required a programmable controller or multiple safety relays. How the two output groups are controlled by the input functions depends on which of the three operating modes is selected (see Selection of operating mode).

Input function 1

A two-channel safety circuit designed for opening contacts, e.g. two-channel emergency stop or ABB Jokab Safety's safety switch JSNY5. One channel is fed with the dynamic signal and the other with static +24 VDC.

Input function 2

A dynamic safety circuit where ABB Jokab Safety's safety sensors Eden, Tina and Spot can easily be connected in series. Up to 12 Eden or Tina devices can be connected in series per input function.

Output group 1

A safe relay output in a duplicated series and a safe transistor output with output voltage of -24 VDC.

Output group 2

A safe relay output in a duplicated series and a safe transistor output with output voltage of -24 VDC. In addition, output group 2 contains a non-safe transistor output with output voltage of +24 VDC, intended for information. The output group can have time delay from 0 to 1.5 s.

Selection of operating modes

Vital 3 can be configured to operate in one of three operating modes M1, M2 or M3. The selection of operating modes is done by connecting one of the terminals M1, M2 or M3 to +24 V.

Operating mode M1 - Separate function Vital 3

Input function 1 controls output group 1, and input function 2 controls output group 2.

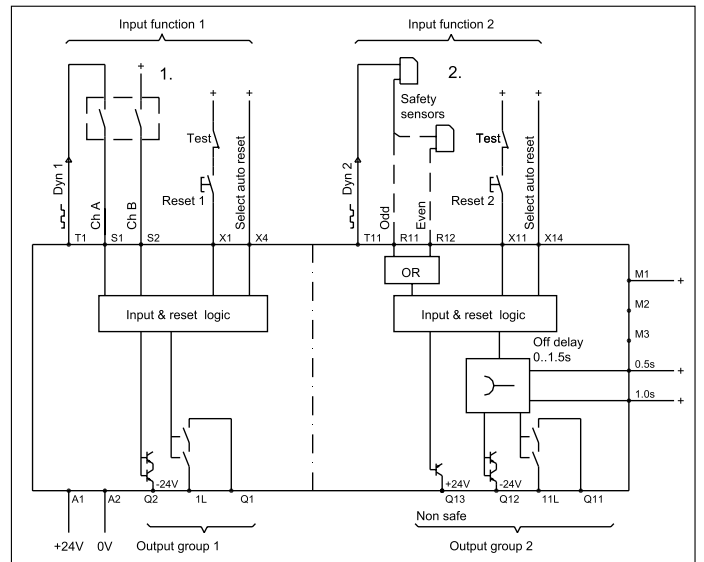

Operating mode M2 - Input 1, master function Vital 3

Input function 1 stops all outputs, and input function 2 stops output group 2.

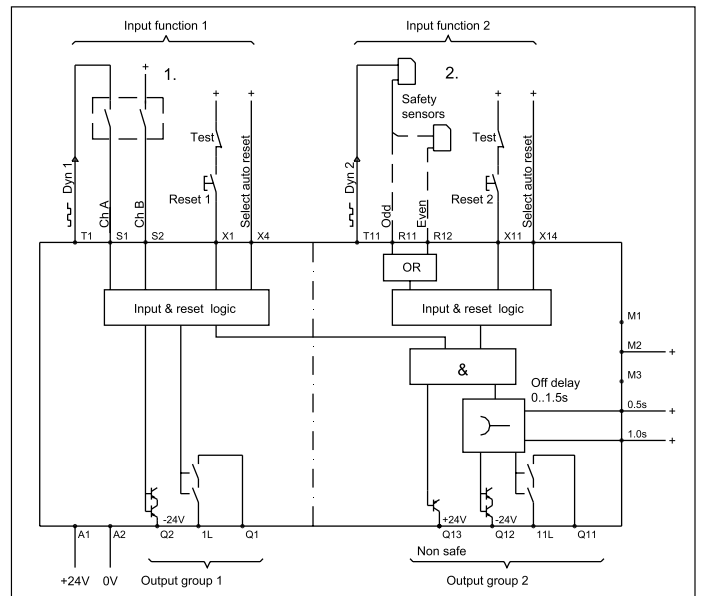

Operating mode M3 - Parallel function Vital 3

Input function 1 and input function 2 operate in parallel and control all outputs. Reset/Auto reset 1 resets both input functions (Reset/Auto Reset 2 is not used).

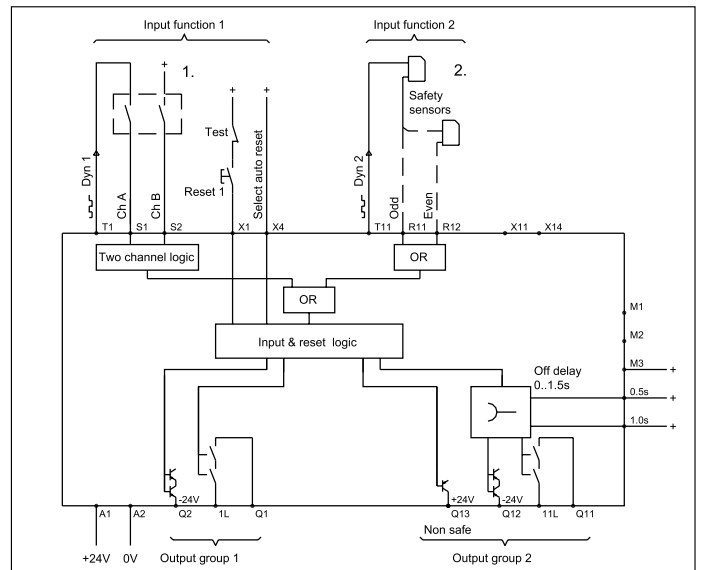

Connection of protection/sensors - Vital 3

Depending on the input function and the number of sensors connected to the safety loop (odd or even number), the dynamic signal is connected between different terminals;

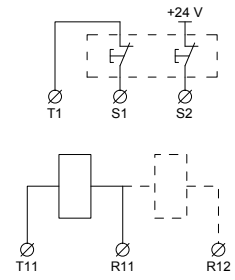

Input function 1

One of the two opening contacts is connected between T1 and S1 (dynamic signal). The second opening contact is connected between +24 V and S2 (static signal).

Input function 2

A dynamic signal is transmitted from T11, and depending on the number of sensors in the safety loop, the signal connects back to R11 (odd number of sensors) or R12 (even number of sensors).

Connection of outputs - Vital 3

Connection of safe transistor output (-24 V)

The safe transistor outputs Q2 (output group 1) and Q12 (output group 2) have an output voltage of -24 V.

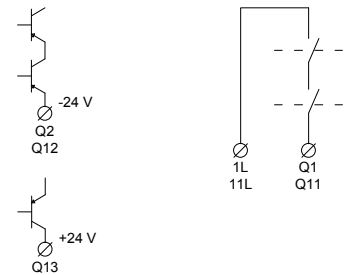

Connection of safe relay output

The safe relay outputs that are duplicated in series break between 1L-Q1 (output group 1) and 11L-Q11 (output group 2). The loads that break should be fitted with spark arresters to protect the outputs. The correct selection of VDR-circuit, RC circuit or diode is appropriate. Note that the diode extends the disconnection time of the load.

Connection of information output

The non-safe transistor output Q13 is high (+24 V) when the outputs from output group 2 are active. The function is therefore dependent on the operating mode selected (see Selection of operating mode).

5

Connection of reset - Vital 3

There are two separate reset functions; Reset 1 and Reset 2. The function of these is dependent on the operating mode selected (see Selection of operating mode). Reset 1 and Reset 2 can be configured for manual or automatic reset independently of each other by means of the input's Auto reset 1 and Auto reset 2.

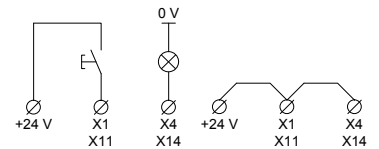

Manual monitored reset

For manual resetting, a push button must be connected between X1 (Reset 1) or X11 (Reset 2) and +24 V. The monitoring contactors for external devices are to be connected in series with the push button. For manual reset, X4 (for Reset 1) and X14 (for Reset 2) serve as output for resetting the indicator lamps.

Automatic reset

For automatic reset, X1 and X4 (Auto reset 1) or X11 and X14 (Auto reset 2) must be connected to +24 V. Monitoring contacts for external devices must be connected between +24 V and X1 (Auto reset 1) or X11 (Auto reset 2). If monitoring contacts are not used, X1 and X11 must be connected to +24 V.

Time delay - Vital 3

Output group 2 can have disconnection delay by connecting inputs 0.5s and 1.0s being connected to +24 V. The system is binary, which means that the time values of the inputs are added together to give the total delay time.



Technical data – Vital 3

Article number	2TLA020070R4400
Level of safety	
EN ISO 13849-1	PL e/Cat. 4
EN 62061	SIL 3
IEC/EN 61508-1...7	SIL 3
EN 954-1	Cat. 4
PFH _b	
Relay output	2.00×10 ⁻⁹
Transistor output	1.50×10 ⁻⁹
Colour	Grey
Weight	390 g
Power supply	24 VDC ±15%
Fuse	
An external fuse must be connected in series with the supply voltage to A1	6 A
Max line resistance at nominal voltage to X1	150 Ohm
Power consumption	
Total current consumption	300 mA
Input function 1 (two channel, normally closed circuit)	
Dynamic output signal	T1
Dynamic input signal	S1
Static input signal (+24 V)	S2
Input function 2 (dynamic safety circuit)	
Dynamic output signal	T11
Dynamic input signal	R11 (odd number of sensors in a circuit) R12 (even number of sensors in a circuit)
Reset input X1/X11	
Voltage at X1/X11 when reset	+24 VDC
Reset current	30 mA (300 mA peak during contact closure)
Minimum contact closure time for reset	80 ms
Number of sensors	
Max. number of Eden or Tina units per input function 2	10
Total max. cable length (depending on the number of Eden/Tina units)	500 m
Max. number of light beams (Spot T/R) per input function 2	
Spot 10	1
Spot 35	3
Total max. cable length (depending on the number of Spot T/R)	100 m
Maximum number of units varies depending on the installation and cable size. For more information, see the examples in this chapter.	
Response time	
Relay output (Q1, Q11)	15 – 24 ms
Safe transistor outputs (Q2, Q12)	11 – 20 ms
Non-safe transistor output (Q2, Q12)	11 – 20 ms

Relay outputs	
Number of outputs	2 NO
Max. load capacity, res. load	6A/250 VAC
Max. load capacity, ind. load	AC-12: 250 V/1,5 A AC-15: 250 V/1,5 A DC-12: 50 V/1,5 A DC-13: 24 V/1,5 A
Safe transistor outputs	
Number of outputs	2
Output voltage (rated)	-24V
Output voltage (at load)	> 22V at 800 mA/24V supply voltage 23.3V at 150 mA/24V supply voltage
Max. load	800 mA
Short circuit protection	
Output – 0V	Yes
Output – +24V	Normal (not guaranteed)
Non-safe transistor output (information)	
Output voltage (rated)	+24 VDC
Max. load	1 A
Mounting	
DIN rail	35 mm DIN rail
Operating temperature range	-10°C to + 55°C
Connection blocks (detachable)	
Max screw torque	1 Nm
Max connection area:	
Solid conductors	1x4 mm ² / 2x1.5 mm ² / 12AWG
Conductor with socket contact	1x2.5 mm ² / 2x1 mm ²
Air and creep distance	4kV/2 DIN VDE 0110
Protection class	
Enclosure	IP40 IEC 60529
Connection blocks	IP20 IEC 60529
Approved standards	EN ISO 13849-1/EN 954-1, EN ISO 13849-2, EN 62061, EN 61496-1, EN 574, EN 692, EN 60204-1, EN 50178, EN 61000-6-2, EN 61000-6-4, EN 61000-4-, IEC/EN 61508-1...7

5

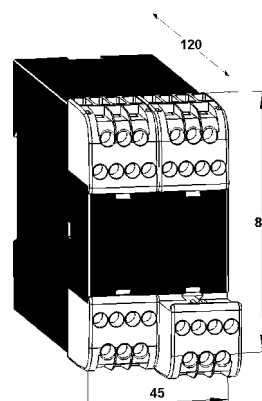

Connector blocks are detachable (without cables having to be disconnected)

Why should you use the Tina adapter units?

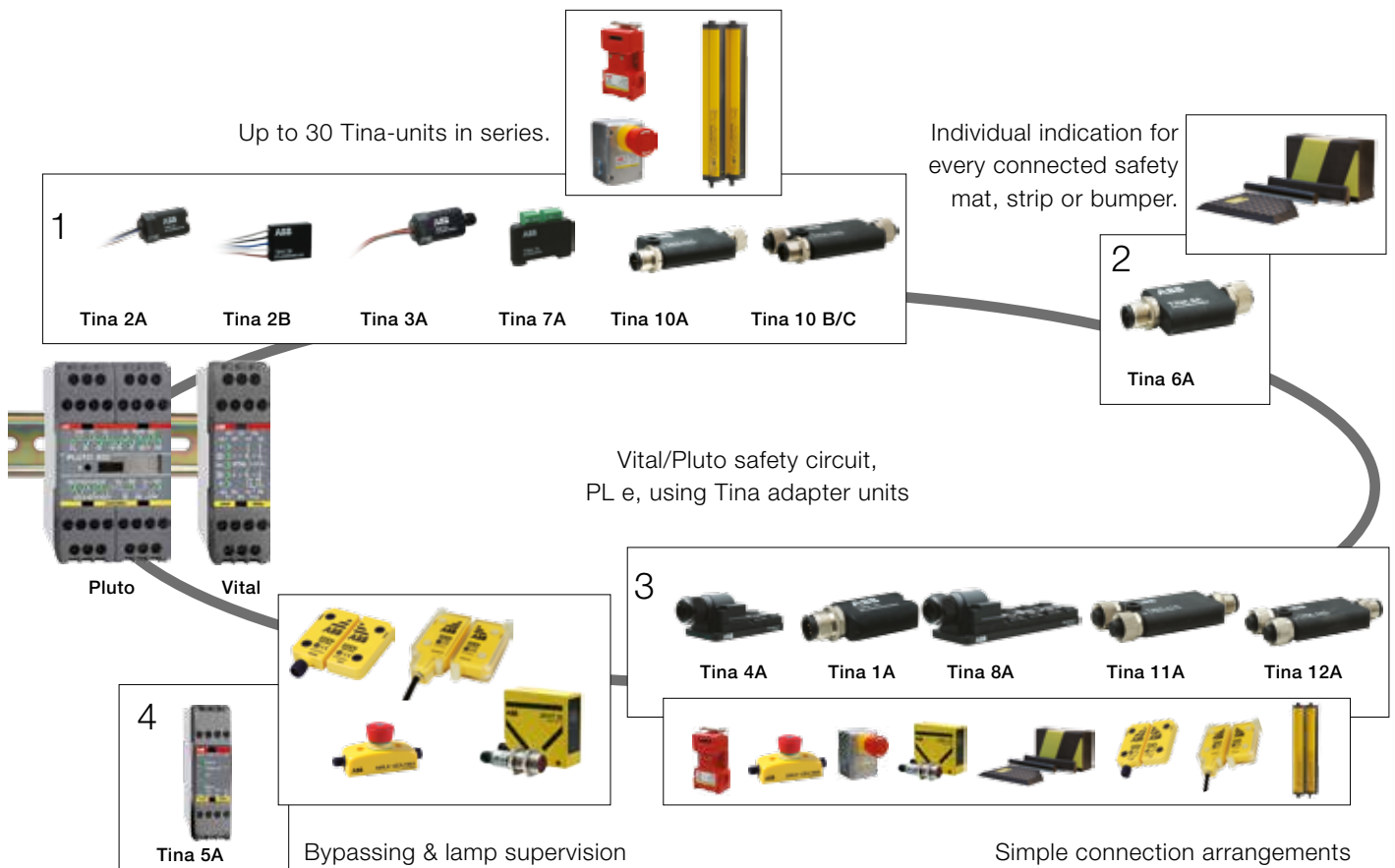

– to adapt safety sensors to the dynamic single channel circuit according to PL e!

The Tina devices adapt safety sensors with mechanical positive forced disconnecting contacts, such as emergency stops, switches and light grids/curtains with dual outputs to the dynamic safety circuit in Vital and Pluto. This means Pluto complies with EN ISO 13849-1 and SIL 3 in EN 62061 and EN 61508 for the connected safety sensors with the Vital/Pluto controller. Note that ABB Jokab Safety's dynamic safety sensors, such as Eden and Spot can be connected directly to the Vital/Pluto circuit without intermediate Tina devices.

– for bypassing of safety sensor in a dynamic circuit!

The Tina 5A bypass unit is used for bypassing of safety sensor in a dynamic circuit and provides the possibility for supervision of bypass lamp indication. During bypassing of safety devices e.g. a light grid or an interlocked gate switch/sensor, it must only be possible to allow the bypass function if a lamp indication is given. The lamp indication must therefore be supervised. With this system it is possible to bypass one or more safety sensor at the same time.

– as a connection block for simplified connection to a dynamic circuit!

The Tina 4A/8A connection blocks are available with 4 or 8 M12 connections. They are used to enable several safety sensor having M12 connection terminated cables to be connected together. The blocks are connected with a suitable multi-core cable, that contains status information from each safety component, to the control cabinet. This enables simplified wiring. The connection block contains electronic circuits which modify the coded dynamic signal in the safety circuit. Note Several connection blocks can be connected to one Vital/Pluto. Using Tina 4A/8A connection blocks eliminates connection faults and can significantly reduce system cable costs.

Tina is available in several versions

Tina is available in several versions depending on the type of safety component that is connected to the Vital or Pluto circuit. Also available is a bypassing unit, three connector blocks with 2, 4 or 8 M12 connectors, and a blind plug for unused connections. As an accessory there is a Y-connector for series or parallel connection and even for connection of light beams with separate transmitter and receiver. Tina units are also included in emergency stop models Smile Tina and INCA Tina. This is to adapt ABB Jokab Safety's products to dynamic safety circuits.

All Tina units are designed to decode the dynamic signal in the safety circuit of Vital/Pluto.

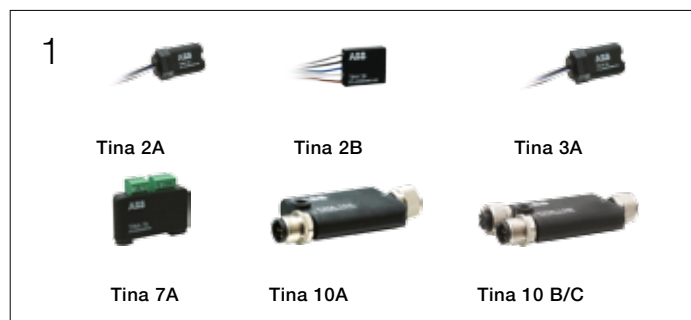

Tina 2A/B, Tina 3A and Tina 7A are used to connect safety components with mechanical positive forced disconnecting contacts, such as emergency stops, switches and light curtains/light beams with relay outputs. NOTE! In order to maintain safety category 4 and to reduce the risk of electrical interference, Tina 2 A, 3A and 7A units must be installed within the same physical encapsulation as the safety component that is to be monitored, and this is to be connected to the Tina unit with as short a cable as possible.

Tina 10A/B/C units are used for connection of Focus light beams/curtains to Vital or Pluto. Tina 10B has an extra M12 connector that enables reset, a reset lamp and switching of the Focus supply voltage. The Tina 10C has an additional M12 connector that permits a Focus transmitter to receive power.



Tina 6A is used to connect door sensitive edges and safety mats, and provides an indication for each unit (Tina 7A may also be used). If a Tina 6A is connected close to the edge or mat, the risk of electrical interference is reduced.



Tina 4A, Tina 8A, Tina 11A and Tina 12A are used as terminal blocks and simplify connection to a Vital safety circuit. Each safety component is connected to the terminal block via an M12 connection. A terminal block is connected to the apparatus enclosure by means of a cable that also contains status information from each safety component that is connected to Tina 4A/Tina 8A and summed information from Tina 11A/Tina 12A. Tina 1A must be used as a blanking plug in unused M12 connections.



Tina 5A is used to bypass the safety sensors in Vital security loop and for monitoring the indicator light switch off. Tina 5A bypass units are used for bypassing of safety sensors in a dynamic circuit and provides the possibility for supervision of bypass lamp indication.

Reasons to choose Tina

- Safety circuit, PL e, EN ISO 13849-1
- Individual status indication of every connected unit in the safety circuit
- Supervision of lamp indicating bypassing of safety device
- Quick release M12 connector

Blanking plug for connection block Tina 1A

Approvals:



Application:

- Is used as a blanking plug in unused M12 connectors at connection blocks

Features:

- Indication of status by LED



Technical data – Tina 1A

Article number	2TLA020054R0000
Level of safety	
IEC/EN 61508-1...7	SIL3
EN 62061	SIL3
EN ISO 13849-1	PL e/Cat. 4
PFH _b	4.50 × 10 ⁻⁹
Power supply	
Operating voltage	24 VDC + +15%, -25%
Total current consumption	17 mA (27 mA with max information output)
Time delay t (in/out)	Information output: Max 10 mA t < 60 µs
Voltage supply at normal operation (protection OK) and 24 VDC supply voltage	Dynamic input: between 9 and 13 volt (RMS) Dynamic output: between 9 and 13 volt (RMS) Information output: ~ 23 VDC
Protection class	IP67
Ambient temperature	Storage: -30...+70°C Operation: -10...+55°C
Humidity range	35 to 85 % (with no icing or condensation)
Housing material	Based on polyamide, Macromelt OM646 (V0)
Connector	M12 5-pole male
Size	48 × 23 × 15 mm (L x W x H)
Weight	~20 g
Colour	Black
Approved standards	European Machinery Directive 2006/42/EC EN ISO 12100-1:2003, EN ISO 12100-2:2003, EN 60204-1:2007, EN ISO 13849-1:2008, EN 62061:2005
Certificates	TÜV Nord

Description

Tina 1A is a device that is designed for use with the connection blocks Tina 4A or Tina 8A where it is used as a blind plug in unused M12 connections. The device is fitted with a LED for status indication of the dynamic safety circuit.

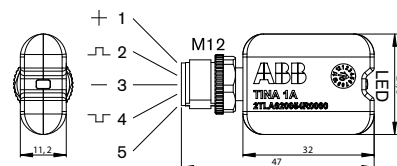

- 5-pin M12 male contact
1. +24 VDC
 2. Dynamic input signal
 3. 0 VDC
 4. Dynamic output signal
 5. Not used

Adaptation unit Tina 2A/B

Approvals:



Application:

- Adaptation of safety sensors with mechanical contacts to the dynamic safety circuit.

Example:

- Emergency stops
- Switches
- Light beams / light curtains with relay outputs

Features:

- Simplifies the system as well as maintaining the safety level
- Indication of status by LED

Technical data – Tina 2A

Article number	Tina 2A Tina 2B	2TLA020054R0100 2TLA020054R1100
Level of safety	IEC/EN 61508-1...7 EN 62061 EN ISO 13849-1	SIL3 SIL3 PL e/Cat. 4
PFH _e		4.50 × 10 ⁻⁹
Power supply	Operating voltage Total current consumption	24 VDC + 15 %, -25 % 17 mA (27 mA with max information output) Information output: Max 10 mA
Time delay t (in/out)		t < 60 μs
Voltage supply at normal operation (protection OK) and 24 VDC supply voltage		Dynamic input: between 9 and 13 volt (RMS) Dynamic output: between 9 and 13 volt (RMS) Information output: ~ 23 VDC
Protection class		IP67
Ambient temperature		Storage: -30...+70°C Operation: -10...+55°C
Humidity range		35 to 85 % (with no icing or condensation)
Housing material		Based on polyamide, Macromelt OM646 (V0)
Connector		5 x 0.34 mm ² wires, 0.15 m
Size		Tina 2A: 43 × 24 × 24 mm Tina 2B: 28 × 21 × 7 mm (L x W x H)
Weight		Tina 2A: ~30 g Tina 2B: ~20 g
Colour		Black
Approved standards		European Machinery Directive 2006/42/EC EN ISO 12100-1:2003, EN ISO 12100-2:2003, EN 60204-1:2007, EN 954 1:1996, EN ISO 13849-1:2008, EN 62061:2005
Certificates		TÜV Nord

Description

Tina 2A/B is a device that adapts the safety sensors with mechanical positive forced disconnecting contacts, such as emergency stops, switches and light curtains/light grids with their own relay outputs to the dynamic safety circuit.

Tina 2A is fitted with M20 contact which simplifies connection to safety sensors prepared for M20 connection. Tina 2B is very small and can often be placed in the safety components' enclosure. Both Tina 2A and Tina 2B are fitted with LEDs for status indication of the dynamic safety circuit.

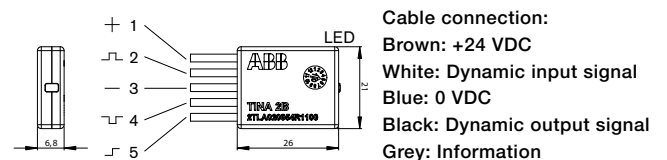
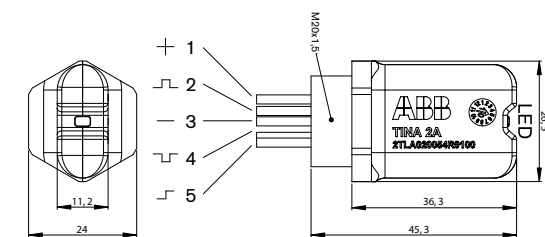

Cable connection:

- Brown: +24 VDC
- White: Dynamic input signal
- Blue: 0 VDC
- Black: Dynamic output signal
- Grey: Information

Adaptation unit Tina 3A/Aps

Approvals:



Application:

- Adaptation of mechanical positive forced disconnecting contacts to the dynamic safety circuit.

Example:

- Emergency stops
- Switches
- Light beams / light curtains with relay outputs

Features:

- Simplifies the system as well as maintaining the safety level
- Indication of status by LED

5

Technical data – Tina 3A

Article number	
Tina 3A	2TLA020054R0200
Tina 3Aps	2TLA020054R1400
Level of safety	
IEC/EN 61508-1...7	SIL3
EN 62061	SIL3
EN ISO 13849-1	PL e/Cat. 4
PFH_b	4.50 × 10 ⁻⁹
Power supply	
Operating voltage	24 VDC + +15%, -25%
Total current consumption	47 mA (57 mA with max information output)
Time delay t (in/out)	Information output: Max 10 mA t < 70 μs
Current through safety device contacts	12 mA
Short circuit current between contacts	10 mA
Voltage supply at normal operation (protection OK) and 24 VDC supply voltage	Dynamic input: between 9 and 13 volt (RMS) Dynamic output: between 9 and 13 volt (RMS) Information output: ~ 23 VDC
Protection class	IP67
Ambient temperature	Storage: -30...+70°C Operation: -10...+55°C
Humidity range	35 to 85 % (with no icing or condensation)
Housing material	Based on polyamide, Macromelt OM646 (V0)
Connectors	
	M12 5-pole connector
	Green loop wires (A1 & A2)
	Orange loop wires (B1 & B2)
	Brown (+24 VDC), Blue (0 VDC) wires (Tina 3Aps only)
Size	54 × 24 × 24 mm (L x W x H)
Weight	~30 g
Colour	Black
Approved standards	European Machinery Directive 2006/42/EC, EN ISO 12100 1:2003, EN ISO 12100-2:2003, EN 60204-1:2007, EN ISO 13849-1:2008, EN 62061:2005
Certificates	TÜV Nord

Description

Tina 3A/Aps is a device that adapts the safety sensors with mechanical positive forced disconnecting contacts, such as emergency stops, switches and light curtains/light grids with their own relay outputs to the dynamic safety loop.

Both Tina 3A and Tina 3Aps are fitted with M20 contacts which simplifies connection to safety sensors prepared for M20 connection. The devices are then easily connected to the dynamic safety loop through a 5-pin M12 contact to the Tina device. Tina 3Aps has an extra conductor for the supply voltage to the safety sensor.

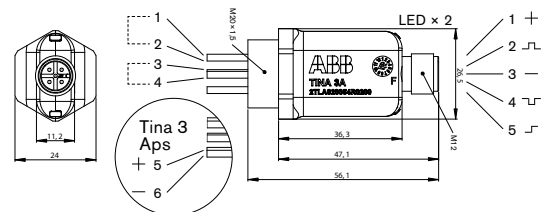

Cable connection:

1. Safety circuit A1-A2
2. Safety circuit A1-A2
3. Safety circuit B1-B2
4. Safety circuit B1-B2
5. Brown: +24 VDC (only Tina 3 Aps)
6. Blue: 0 VDC (only Tina 3Aps)

5-pin M12 male contact:

1. +24 VDC
2. Dynamic input signal
3. 0 VDC
4. Dynamic output signal
5. Not used

Connection block Tina 4A



Approvals:



Application:

- Connection block for up to four safety sensors adapted to the dynamic safety circuit.

Features:

- Simplifies cable routing and reduces cable costs.
- Allows branching of up to four safety sensors to the dynamic safety circuit.

Technical data – Tina 4A

Article number Tina 4A	2TLA020054R0300
Level of safety IEC/EN 61508-1...7 EN 62061 EN ISO 13849-1	SIL3 SIL3 PL e/Cat. 4
PFH _b	4.50 × 10 ⁻⁹
Power supply Operating voltage Total current consumption	24 VDC + +15%, -15% 10 mA (20 mA with max information summary output) Information output: Max 10 mA
Time delay t (in/out)	t < 60 μs
Voltage supply at normal operation (protection OK) and 24 VDC supply voltage	Dynamic input: between 9 and 13 volt (RMS) Dynamic output: between 9 and 13 volt (RMS) Information output: ~ 23 VDC
Protection class	IP67
Ambient temperature	Storage: -30...+70°C Operation: -10...+55°C
Humidity range	35 to 85 % (with no icing or condensation)
Housing material	Based on polyamide, Macromelt OM646 (V0)
Connectors	M12 5-pole female (4x) 9-pin connection block
Size	99 × 50 × 43 mm (L x W x H)
Weight	~100 g
Colour	Black
Approved standards	European Machinery Directive 2006/42/EC EN ISO 12100-1:2003, EN ISO 12100-2:2003, EN 60204-1:2007, EN ISO 13849-1:2008, EN 62061:2005
Certificates	TÜV Nord

Description

Tina 4A is a connection block with four 5-pin M12 connections. It is used to connect multiple safety sensors with M12 contacts via a single cable to a controller or PLC. This simplifies cable running and reduces cable costs. Multiple connection blocks can be connected to a Vital/Pluto. Tina 1A is used for unused M12 connections.

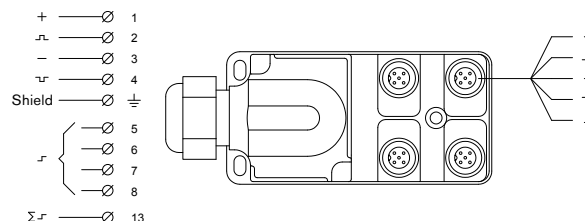

Connection block:

1. +24 VDC
2. Dynamic input signal
3. 0 VDC
4. Dynamic output signal
5. Information (contact #1)
6. Information (contact #2)
7. Information (contact #3)
8. Information (contact #4)
13. Summarized information (contact #1-4)

5-pin M12 female contact (x4):

1. +24 VDC
2. Dynamic input signal
3. 0 VDC
4. Dynamic output signal
5. Information

Adaptation unit Tina 5A



Approvals:



Application:

- Bypassing of safety device connected to the dynamic safety circuit and for supervision of lamp indication.

Features:

- One or more safety devices can be bypassed
- supervised lamp indication
- Indication of status by LEDs

5

Function

The Tina 5A is designed for bypassing of safety devices connected to the Vital/Pluto safety circuit and for supervision of lamp indication.

During bypassing of safety devices e.g. a light grid or an interlocked gate, it must only be possible to allow the bypass function if a lamp indication is on. The lamp indication must therefore be supervised. Whether indication is required depends on the specific situation and result of risk analysis.

When the Tina 5A receives a coded dynamic signal to S1 and the bypass indication lamp is on (connected across L1-L2), a bypassing output signal is provided on S2 and S3. A broken or short circuit in the indication lamp leads to an interruption of the bypass output signal on S2 and S3, therefore stopping the bypassing.

The dynamic signal to S1 on Tina 5A must be the input signal from the first of the safety devices intended to bypass. The signal can be connected via output contacts from a safety relay, a safety timer or be initiated via a unit providing the dynamic coded signal as for example an Eden sensor or a Spot light beam. The dynamic output from S2 or S3 is connected to the output of the safeguards to be bypassed

S2 is used if:

- an odd number of dynamic safety units is to be bypassed using an odd number of dynamic safety units, i.e. the sum of Tina + Eden and Spot units (incl. Tina 5A). See drawing HE3824C
- an even number of dynamic safety units is to be bypassed using an even number of dynamic safety units, i.e. the sum of Tina + Eden and Spot units (incl. Tina 5A). See drawing HE3824F

S3 is used if:

- an odd number of dynamic safety units is to be bypassed using an even number of dynamic safety units, i.e. the sum of Tina + Eden and Spot units (incl. Tina 5A). See drawing HE3824D
- an even number of dynamic safety units is to be bypassed using an odd number of dynamic safety units, i.e. the sum of Tina + Eden and Spot units (incl. Tina 5A). See drawing HE3824E

The total number of dynamic safety units is calculated by adding the number of Eden, Spot and Tina units connected in the Vital circuit. See the connection examples HE3824C, D, E, F or G.

Technical data – Tina 5A

Article number	2TLA020054R1900
Level of safety	SIL3
IEC/EN 61508-1...7	SIL3
EN 62061	PL e/Cat. 4
EN ISO 13849-1	
PFH _D	4.50 × 10 ⁻⁹
Power supply	
Operating voltage	24 VDC + +10%, -10%
Current consumption, A1-A2	No bypass: 10 mA
Bypass connection	Bypass using a 5 W indication lamp: 240 mA Tina 5A can bypass max. 30 Eden/Tina-units or 6 Spot T/R
Time delay t (in/out)	t < 260 μs
Voltage supply at normal operation (protection OK) and 24 VDC supply voltage	Dynamic input: between 9 and 13 volt (RMS) Dynamic output: between 9 and 13 volt (RMS) Information output: ~ 23 VDC
Protection class	Enclosure: IP40 Connection block: IP20
Ambient temperature	-10...+55°C
Humidity range	35 to 85 % (with no icing or condensation)
Housing material	Based on polyamide, Macromelt OM646 (V0)
Connectors	Connection blocks with a total of 8 terminals (2 x 4)
Mounting	35 mm DIN rail
Size	120 × 84 × 22.5 mm (L x W x H)
Weight	~135 g
Colour	Grey
Approved standards	European Machinery Directive 2006/42/EC, EN ISO 12100-1:2003, EN ISO 12100-2:2003, EN 60204-1:2007, EN ISO 13849-1:2008, EN 62061:2005, EN 61496-1:2004 + A1:2008
Certificates	TÜV Nord

Bypassing of Eden and Tina units

If one or more Eden or Tina units are bypassed by a Tina 5A, a diode, such as a 1N4007 must be inserted with forward current out from pin 4 of the last bypassed unit. If one or more Eden or Tina units are bypassed by one or more Eden or Tina units direct to each other, a diode, such as a 1N4007 must be inserted by the last unit in both loops with forward current out from pin 4. Refer to example HD3801A. In the case of bypassing of a Tina 10A, B or C or of more than one unit towards each other, it is recommended that a Tina 5A or M12-3M is used. See the examples HE3824C, D, E, F or G.

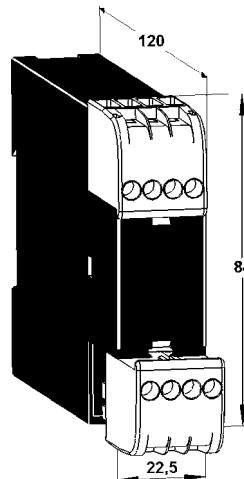

Connections:

- +A1:** +24 VDC
- Y14:** Information of bypass
- L1-L2:** Bypass lamp
(or 820 ohm/2W resistor)
- A2:** 0 VDC
- S1:** Dynamic signal in
- S2:** Dynamic signal out, transcoded
- S3:** Dynamic signal out, transcoded twice

Adaptation unit Tina 6A



Approvals:



Application:

- Short circuit monitoring and adaptation of safety sensors to the dynamic safety circuit
- For example:
Contact edges
Bumpers
Safety mats

Features:

- Simplifies the system as well as maintaining the safety level
- Indication of status by LED

5

Technical data – Tina 6A

Article number	2TLA020054R0600
Level of safety IEC/EN 61508-1...7 EN 62061 EN ISO 13849-1	SIL3 SIL3 PL e/Cat. 4
PFH _b	4,50 × 10 ⁻⁹
Power supply	
Operating voltage	24 VDC + +15%, -25%
Total current consumption	47 mA (57 mA with max information output) Information output: Max 10 mA
Current through safety device contacts	12 mA
Short circuit current between contacts	10 mA
Time delay t (in/out)	t < 70 μs
Voltage supply at normal operation (protection OK) and 24 VDC supply voltage	Dynamic input: between 9 and 13 volt (RMS) Dynamic output: between 9 and 13 volt (RMS) Information output: ~ 23 VDC
Protection class	IP67
Ambient temperature	Storage: -30...+70°C Operation: -10...+55°C
Humidity range	35 to 85 % (with no icing or condensation)
Housing material	Based on polyamide, Macromelt OM646 (V0)
Connectors	M12 5-pole male M12 5-pole female
Size	63 × 31 × 15 (L × W × H)
Weight	~30 g
Colour	Black
Approved standards	European Machinery Directive 2006/42/EC EN ISO 12100-1:2003, EN ISO 12100-2:2003, EN 60204-1:2007, EN ISO 13849-1:2008, EN 62061:2005
Certificates	TÜV Nord

Description

Tina 6A monitors short circuits. It is used to adapt the safety sensors with safety contact strips and safety mats with relay outputs to the dynamic safety circuit. The device is fitted with a LED for status indication of the dynamic safety circuit.

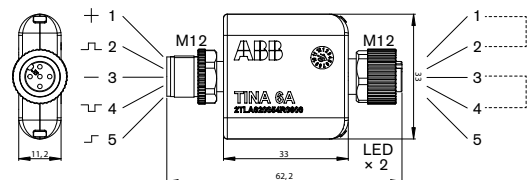

- 5-pin M12 male contact:
1. +24 VDC
 2. Dynamic input signal
 3. 0 VDC
 4. Dynamic output signal
- Information

- 5-pin M12 female contact:
1. Safety circuit A1-A2
 2. Safety circuit A1-A2
 3. Safety circuit B1-B2
 4. Safety circuit B1-B2 Not used

Adaptation unit Tina 7A



Approvals:



Application:

- Adaptation of safety sensors with mechanical contacts to the dynamic safety circuit.
- For example:
Emergency stops
Switches
Light beams / light curtains with relay outputs

Features:

- Simplifies the system as well as maintaining the safety level
- Indication of status by LED
- Adapted for easy installation on 35 mm DIN rail in cabinets

Technical data – Tina 7A

Article number	2TLA020054R0700
Level of safety IEC/EN 61508-1...7 EN 62061 EN ISO 13849-1	SIL3 SIL3 PL e/Cat. 4
PFH _b	4.50 × 10 ⁻⁹
Power supply Operating voltage Total current consumption	24 VDC + +15%, -25% 47 mA (57 mA with max information output) Information output: Max 10 mA
Current through safety device contacts Short circuit current between contacts Time delay t (in/out) Voltage supply at normal operation (protection OK) and 24 VDC supply voltage	12 mA 10 mA t < 70 μs Dynamic input: between 9 and 13 volt (RMS) Dynamic output: between 9 and 13 volt (RMS) Information output: ~ 23 VDC
Protection class	IP20
Ambient temperature	Storage: -30...+70°C Operation: -10...+55°C
Humidity range	35 to 85 % (with no icing or condensation)
Housing material	Based on polyamide, Macromelt OM646 (V0)
Connectors	5-pin connection block (power supply, dynamic in/out, info) 4-pin connection block (safety loop A1-A2, B1-B2)
Mounting	DIN rail
Size	61 × 46 × 14 (L × W × H)
Weight	~35 g
Colour	Black
Approved standards	European Machinery Directive 2006/42/EC, EN ISO 12100-1:2003, EN ISO 12100-2:2003, EN 60204-1:2007, EN ISO 13849-1:2008, EN 62061:2005
Certificates	TÜV Nord

Description

Tina 7A is a device that adapts the safety sensors with mechanical positive forced disconnecting contacts, such as emergency stops, switches and light curtains/light grids with their own relay outputs to the dynamic safety circuit.

The device is designed for installation in an equipment cabinet where it can be mounted directly on a 35 mm DIN busbar, and the conductors are then connected directly to the screw terminals.

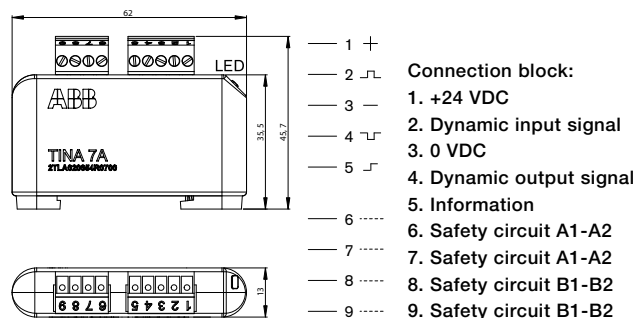

Connection block Tina 8A

Approvals:



Application:

- Connection block for up to eight safety sensors adapted to the dynamic safety circuit.

Features:

- Simplifies cable routing and reduces cable costs.
- Allows branching of up to four safety sensors to the dynamic safety circuit.



Technical data – Tina 8A

Article number	2TLA020054R0500
Level of safety IEC/EN 61508-1...7 EN 62061 EN ISO 13849-1	SIL3 SIL3 PL e/Cat. 4
PFH _b	4.50 × 10 ⁻⁹
Power supply Operating voltage Total current consumption	24 VDC + +15%, -15% 15 mA (25 mA with max information summary output) Information output: Max 10 mA t < 60 μs
Time delay t (in/out) Voltage supply at normal operation (protection OK) and 24 VDC supply voltage	Dynamic input: between 9 and 13 volt (RMS) Dynamic output: between 9 and 13 volt (RMS) Information output: ~ 23 VDC
Protection class	IP67
Ambient temperature	Storage: -30...+70°C Operation: -10...+55°C
Humidity range	35 to 85 % (with no icing or condensation)
Housing material	Based on polyamide, Macromelt OM646 (V0)
Connectors	M12 5-pole female (8x) 13-pin connection block
Size	149 × 50 × 43 (L × W × H)
Weight	~140 g
Colour	Black
Approved standards	European Machinery Directive 2006/42/EC, EN ISO 12100-1:2003, EN ISO 12100-2:2003, EN 60204-1:2007, EN ISO 13849-1:2008, EN 62061:2005
Certificates	TÜV Nord

Tina 8A is a connection block with eight 5-pin M12 connections. It is used to connect multiple safety sensors with M12 contacts via a single cable to a controller or PLC. This simplifies cable running and reduces cable costs. Multiple connection blocks can be connected to a Vital/Pluto. Tina 1A is used for unused M12 connections.

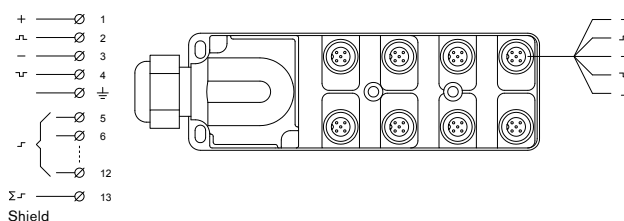

Connection block:

1. +24 VDC
2. Dynamic input signal
3. 0 VDC
4. Dynamic output signal $\frac{1}{2}$ Cable shield
5. Information (contact #1)
6. Information (contact #2)
7. Information (contact #3)
8. Information (contact #4)
9. Information (contact #5)
10. Information (contact #6)
11. Information (contact #7)
12. Information (contact #8)
13. Summarized information (contact #1-8)

5-pin M12 female contact (x8):

1. +24 VDC
2. Dynamic input signal
3. 0 VDC
4. Dynamic output signal
5. Information

Connection examples of safety sensors to Tina 8A

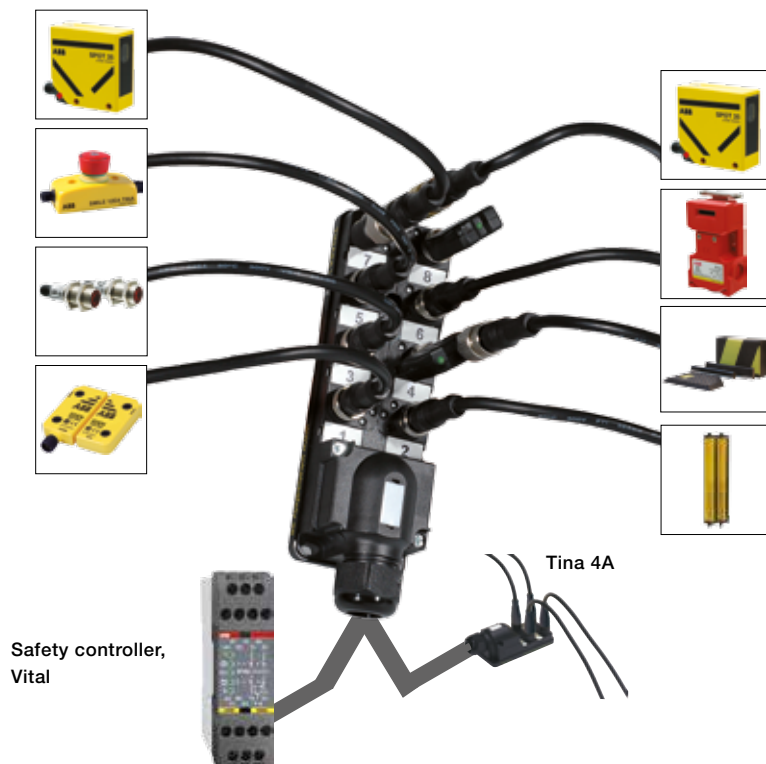

Connection 1

One Eden is connected directly to the Tina 8A. The Eden status is shown by an LED on the Adam sensor. A status information signal is also connected to Tina 8A.

Connection 2

One Focus safety light grid is connected to the Tina 8A via a Tina 10A. The output from the Tina 10A is via a M12 connector. The connection between Tina 10A and Tina 8A is achieved using a cable with M12 connectors on each end. The Tina 10A has two LED's which show the status of the light grid. The same status information signal is connected to the Tina 8A. Tina 10A and the Focus transmitter are connected, via an M12-3B, to Tina 8A.

Connection 3

A Spot 10 light beam is connected directly to Tina 8A. A 'Y' connector M12-3B for M12 plugs is connected to the transmitter and the receiver. The status information shown on the Spot LED is also connected to Tina 8A.

Connection 4

A safety mat (same for safety strip and safety bumper) is connected via a Tina 6 A to the Tina 8A. Two LEDs in Tina 6A shows the status of the mat. The same status information signal is connected to Tina 8A.

Connection 5

One Smile is connected to the Tina 8A. The information shown by an LED on the Smile is also connected to the terminal block on the Tina 8A.

Connection 6

A safety interlock switch is connected via a Tina 3A mounted directly on the switch. The output from the Tina 3A is via a M12 connector. The connection between the Tina 3A and the Tina 8A is therefore simply made with a cable with M12 connectors on each end. On the Tina 3A there is a LED which shows the status of the switch. The same information signal is connected to the Tina 8A.

Connection 7

A Spot 35, transmitter and receiver are connected directly to the Tina 8A via a M12-3B 'Y' connector. The status information shown by the LED on the Spot is also connected to the Tina 8A.

Connection 8

Tina 1A is a plug which has to be connected to Tina 8A inputs when no sensor is required, in order to complete the safety connection circuit.

NOTE! All input connectors on the Tina 8A must be connected to sensors or have Tina 1A plugs fitted.

Adaptation unit Tina 10A/B/C



Approvals:



Application:

- Adaptation of safety sensors with OSSD outputs to the dynamic safety circuit.
- For example:
Focus lightcurtain/lightbeam

Features:

- Simplifies the system as well as maintaining the safety level
- Indication of status by LED

Tina 10 A/B/C are three connection units with M12 connections, that make it easy to connect a light curtain or light beam Focus with OSSD outputs to the dynamic safety circuits of Vital and Pluto. This also enables complete external interconnections, with M12 cabling, which reduces the cabling to and connections in the apparatus enclosure. Tina 10 A/B/C has LEDs for function indication, with green, red or flashing green/red indications.

Tina 10A: has two M12 connections that are connected to 1: Vital/Pluto and 2: a light curtain/light beam Focus receiver. See the connection examples HH3300F, HR7000L-01.

Tina 10B: has three M12 connections that are connected to 1: Vital/Pluto and 2: a light curtain/light beam Focus receiver, and 3: An external reset button and muting lamp, such as unit FMI-1C. See the connection examples HR7000L-01.

Tina 10C: has three M12 connections that are connected to 1: Vital/Pluto and 2: a light curtain/light beam Focus receiver, and 3: a light curtain/light beam Focus Transmitter. See the connection examples HH3302D, HR7000L-01.

Tina 10A, 10B and 10C connections

Focus Receiver

- 1 White +24VDC
- 2 Brown +24VDC
- 3 Green
- 4 Yellow
- 5 Grey OSSD1
- 6 Pink OSSD2
- 7 Blue 0V
- 8 Red LMS

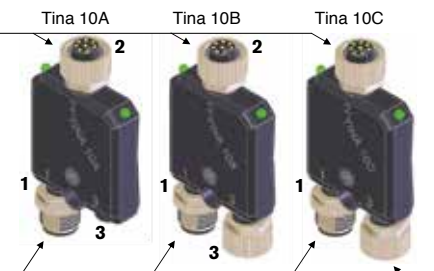

Vital / Pluto

- 1 Brown +24VDC
- 2 White
- 3 Blue 0V
- 4 Black
- 5 Grey

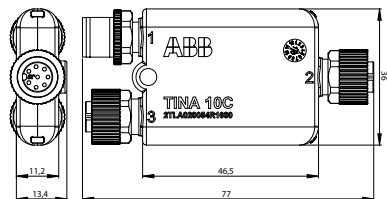
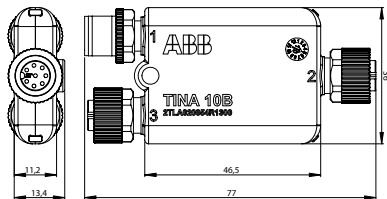
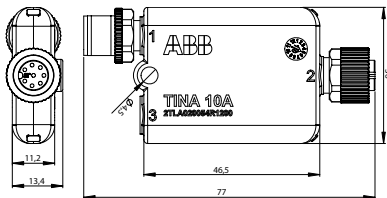
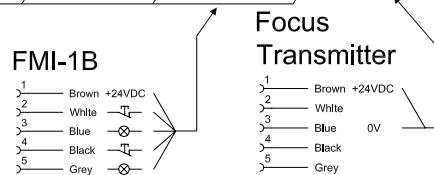

Technical data – Tina 10A/B/C

Article number	
Tina 10A	2TLA020054R1200
Tina 10B	2TLA020054R1300
Tina 10C	2TLA020054R1600
Level of safety	
IEC/EN 61508-1...7	SIL3
EN 62061	SIL3
EN ISO 13849-1	PL e/Cat. 4
PFH_b	
	4.50 × 10 ⁻⁹
Power supply	
Operating voltage	24 VDC + +20%, -20%
Total current consumption	60 mA (70 mA with max. info signal out) Info signal out: Max. 10 mA
Time delay t (in/out)	t < 120 μs
Voltage supply at normal operation (protection OK) and 24 VDC supply voltage	Dynamic input signal: 9 to 13 V (RMS) Dynamic output signal: 9 to 13 V (RMS) Info signal out: ~23 VDC
Protection class	
	IP67
Ambient temperature	
	Storage: -10...+55° C Operation: -10...+55° C
Humidity range	
	35 to 85 % (without icing or condensation)
Housing material	
	Based on polyamide, Macromelt OM646 (V0)
Size	
	74 × 36 × 11 mm (L × W × H)
Weight	
	~40 g
Colour	
	Black
Number of units connected to Vital 1	
Max. number of Tina 10A:	6
Max. number of Tina 10B/C:	4 when Focus is supplied by Vital and a reset lamp is used 6 when Focus is supplied separately or no reset lamp is used
Number of units connected to Pluto, Vital 2 or 3, per input	
Max. number of Tina 10A/B/C:	2
Connectors	
Tina 10A	1: for Vital or Pluto 2: for Focus receiver
Tina 10B	1: for Vital or Pluto 2: for Focus receiver 3: for Reset unit
Tina 10C	1: for Vital or Pluto 2: for Focus receiver 3: for Focus transmitter
Approved standards	
	European Machinery Directive 2006/42/EC EN ISO 12100-1:2003, EN ISO 12100-2:2003, EN 60204-1:2007, EN ISO 13849-1:2008, EN 62061:2005, EN 61496-1:2004 + A1:2008
Certificates	
	TÜV Nord

Terminal block Tina 11A



Approvals:



Application:

- Terminal block for connection of two safety sensors with 5-pin M12 connectors and adaptation to the dynamic safety circuit.

Features:

- Simplifies cable routing and reduces cable costs.
- Allows connection of two safety sensors to the dynamic safety circuit.

Technical data – Tina 11A

Article number	2TLA020054R1700
Level of safety IEC/EN 61508-1...7 EN 62061 EN ISO 13849-1	SIL3 SIL3 PL e/Cat. 4
PFH _b	4.50 × 10 ⁻⁹
Power supply Operating voltage Total current consumption	24 VDC + +15%, -15% 17 mA (27 mA with max information output)
Time delay t (in/out) Voltage supply at normal operation (protection OK) and 24 VDC supply voltage	Information output: Max 10 mA t < 60 μs Dynamic input: between 9 and 13 volt (RMS) Dynamic output: between 9 and 13 volt (RMS) Information output: ~ 23 VDC
Protection class	IP67
Ambient temperature	Storage: -30...+70°C Operation: -10...+55°C
Humidity range	35 to 85 % (with no icing or condensation)
Housing material	Based on polyamide, Macromelt OM646 (V0)
Connectors	Out: M12 5-pole male (nr 2) In: M12 5-pole female (nr 1,3)
Size	74 × 36 × 11 mm (L × W × H)
Weight	~40 g
Colour	Black
Approved standards	European Machinery Directive 2006/42/EC EN ISO 12100-1:2003, EN ISO 12100-2:2003, EN 60204-1:2007, EN ISO 13849-1:2008, EN 62061:2005
Certificates	TÜV Nord

Description

Tina 11A is a connection block with two 5-pin M12 connections. It is used to connect two safety sensors with M12 contacts via a single cable to a controller or PLC. This simplifies cable running and reduces cable costs. Multiple connection blocks can be connected to a Vital/Pluto.

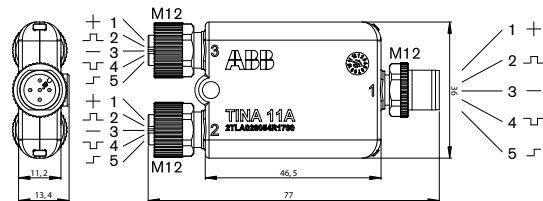

- 5-pin M12 female connector (contact #2-3)**
1. +24 VDC
 2. Dynamic input signal
 3. 0 VDC
 4. Dynamic output signal
 5. Information

- 5-pin M12 male connector (contact #1):**
1. +24 VDC
 2. Dynamic input signal
 3. 0 VDC
 4. Dynamic output signal
 5. Summarized information (contact #2-3)

Terminal block Tina 12A



Approvals:



Application:

- Terminal block for connection of two safety sensors with 8-pin M12 connectors and adaptation to the dynamic safety circuit.
- For example:
Dalton
Magne

Features:

- Simplifies cable routing and reduces cable costs.
- Allows connection of two safety sensors to the dynamic safety circuit.

Technical data – Tina 12A

Article number	2TLA020054R1800
Level of safety IEC/EN 61508-1...7 EN 62061 EN ISO 13849-1	SIL3 SIL3 PL e/Cat. 4
PFH _b	4.50 × 10 ⁻⁹
Power supply Operating voltage Total current consumption	24 VDC + +15%, -15% 60 mA (70 mA with max information output) Information output: Max 10 mA t < 60 μs Dynamic input: between 9 and 13 volt (RMS) Dynamic output: between 9 and 13 volt (RMS) Information output: ~ 23 VDC
Time delay t (in/out) Voltage supply at normal operation (protection OK) and 24 VDC supply voltage	
Protection class	IP67
Ambient temperature	Storage: -30...+70°C Operation: -10...+55°C
Humidity range	35 to 85 % (with no icing or condensation)
Housing material	Based on polyamide, Macromelt OM646 (V0)
Connectors	To Vital/Pluto: M12 8-pole male (nr 2) From safety device: M12 8-pole female (nr 1,3)
Size	74 × 36 × 11 mm (L × W × H)
Weight	~40 g
Colour	Black
Approved standards	European Machinery Directive 2006/42/EC EN ISO 12100-1:2003, EN ISO 12100-2:2003, EN 60204-1:2007, EN ISO 13849-1:2008, EN 62061:2005
Certificates	TÜV Nord

Description

Tina 12A is a connection block with two 8-pin M12 connections. It is used to connect two process locks Dalton or Magne 2A/B with integrated Eden sensors via a single cable to a controller or PLC. This simplifies cable running and reduces cable costs. Multiple connection blocks can be connected to a Vital/Pluto.

Tina 12A has three 8-pin M12 contacts that connect to
1: Pluto/Vital, information for sensors and locks and lock signals

2: Dalton with Eden No 1

3: Dalton with Eden No 2

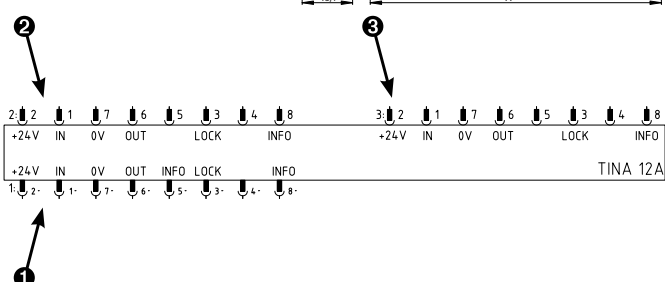
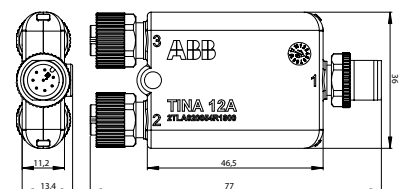

Accessories

'Y' branch with M12 connection and M12-connection device with screw connectors

5

M12-3A

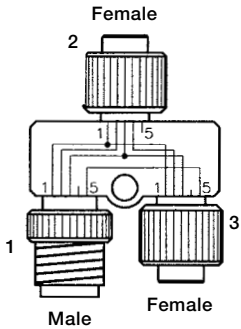

See the connection examples
HA3306C, D
HH3300A, D

M12-3B

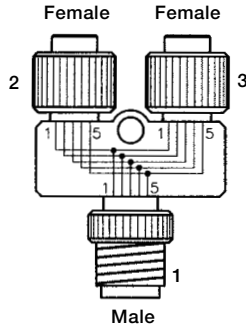

See the connection examples
HA3306C, D.
HH3300D, F.
HH3302D

M12-3D

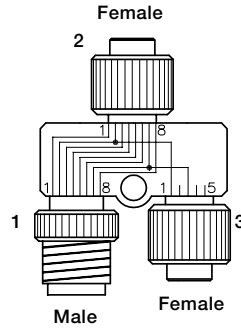

See the connection examples
HB0008A
HR7000O, L.

M12-3E

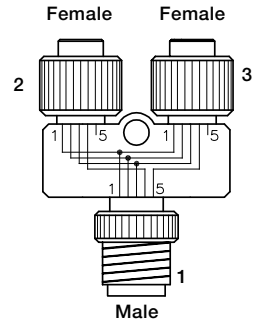

See the connection examples
HB0001A, 2A, 4A and 6A

M12-C01

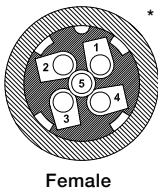

M12-C02

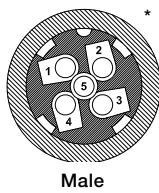

M12-C03

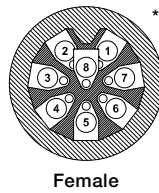

M12-C04

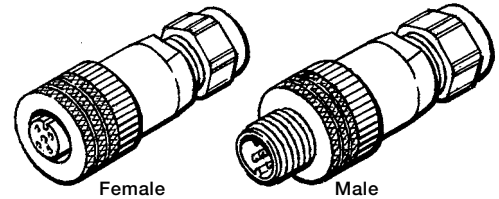
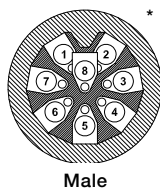

Cabling

Many of ABB Jokab Safety's products are connected using standard M12 connectors. This facilitates installation, saving a lot of time, and also dramatically reduces the risk of incorrect connection.

We have therefore developed cables with 5 conductors, 5 x 0.34 mm + screening or 8 conductors; 8 x 0.34 mm + screening which offer the advantages that we believe a good cable should have. These are available in any length and in various standard lengths, with moulded straight or angled male or female connectors. Particularly suitable cables for the Tina 4A and Tina 8A units are C9 and C13. They have thicker, 0.75 mm² conductors for the feed line and 0.5 mm² for the other conductors + screening. Refer to the component list for the variants that are available.

Advantages

- Area 0.34 mm² and 0.25 mm²
- Always screened cable
- The screen is always connected to negative in male connectors.
- The guide pin in the small connector is indicated by a recessed arrow that is easy to recognise.
- Convenient cable in PVC
- The cable is also available in bulk length.



Example of safety sensor connections based on 'Y' branch

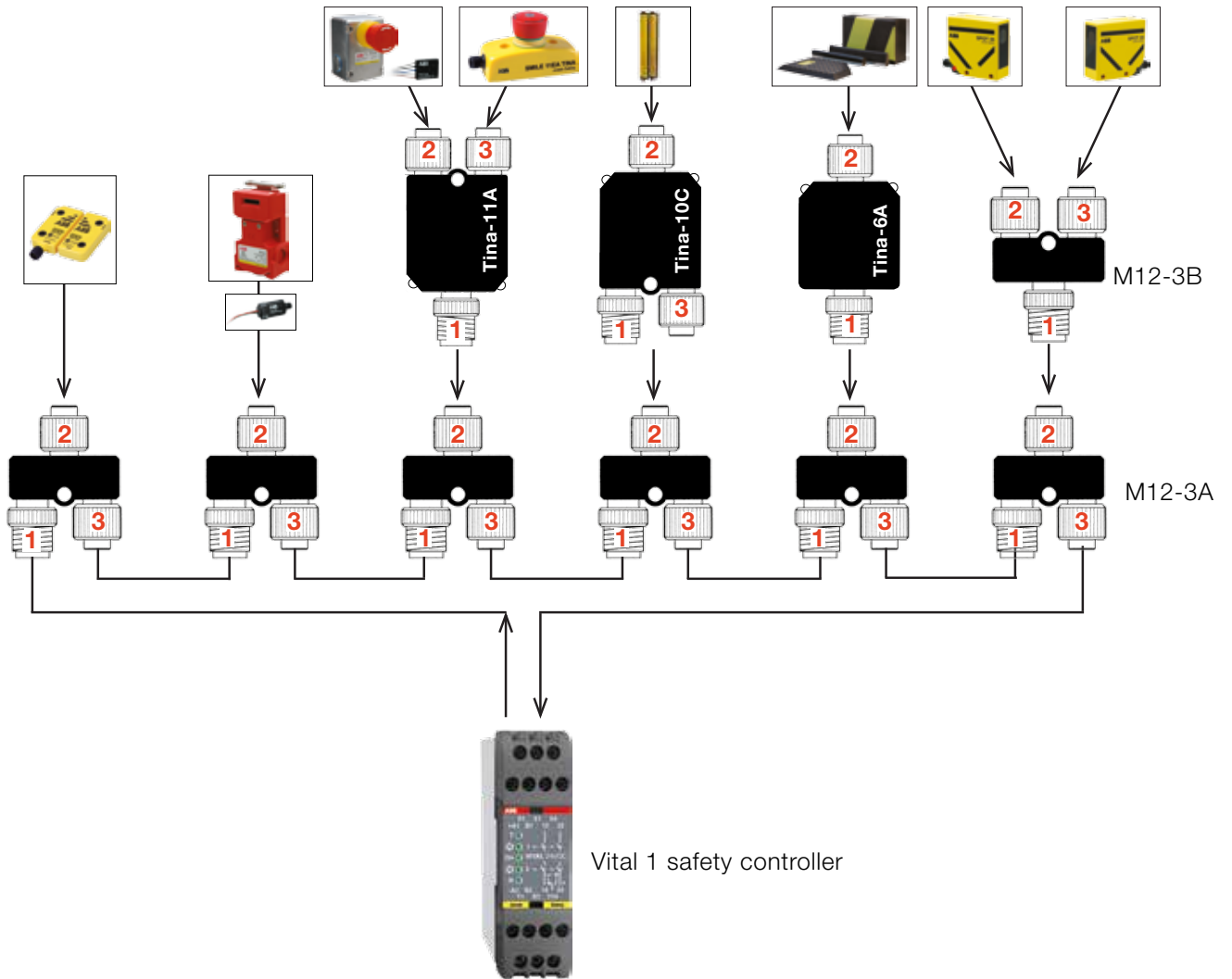

Connection examples

HA3300A-01 Connection example Vital 1	5/41
HA3301A Vital 1 with several Eden	5/41
HA3302A Vital 1 and Tina 4A with 4 Eden	5/42
HA3302B-01 Vital 1 and 2 Tina 4A and 4 Eden and emergency stop	5/42
HA3303A Vital 1 with emergency stop/Tina 2A	5/43
HA3304A Vital 1 with emergency stop/Tina 3A	5/43
HA3305A Vital 1 with Eden and lightgrid Focus/Tina 10C	5/44
HA3306C Vital 1 with 2 lightbeams Spot	5/44
HA3306D Vital 1 with 3 lightbeams Spot	5/45
HA3307A Vital 1 with Eden, lightgrid/Tina 3A and e-stop/Tina 7A	5/45
HD3800A-01 Vital 1 with safety light beam Spot	5/46
HD3801A-01 Vital 1, series and parallel	5/46
HE3811B-01 Safety light beam Spot with time-limited reset	5/47
HE3824C-01 Lightbeam with time-limited bypass 0.2–40 s.	5/47
HE3824D-01 Eden and bypassed lightbeam with Eden	5/48
HE3824E-01 Lightbeams with time-limited bypass 0.2–40 s.	5/48
HE3824F-01 Eden and 2 bypass lightbeams with Eden	5/49
HE3824G-01 Eden and 2 separately bypassed lightbeams	5/49
HH3300A Vital 1 with different types of safety devices and M12–3A	5/50
HH3300D Vital 1 with Tina 4A and different types of safety devices	5/50
HH3302D-01 Vital 1 with Tina 8A and different types of safety devices	5/51
HH3301E-01 Connection example Vital 1	5/51
HH3400A2 Vital 1 solutions	5/52
HB0005A-01 Vital with Eden and Inca e-stop, with separate reset	5/52
HB0006A-01 Vital with 4 Eden units + Reset via M12-3E and Tina 4A	5/53
HB0007A Vital with two Dalton units via Tina 12A	5/53
HB0001A-01 Pluto with Smile e- stop, Reset and Adam via Tina 4A	5/54
HB0002A-01 Pluto with Eden units, two zones via M12-3E and Tina 4A	5/54
HB0003A-01 Pluto with e-stop units, via Tina 11A and Tina 4A	5/55
HB0004A Pluto with different zones for Eden + Reset and Eden units	5/55
HH3301D-01 Vital 1 and Tina 8A with different safety device types	5/56

Connection examples

HA3302A-01 Vital 1 and Tina 4A with 4 Eden

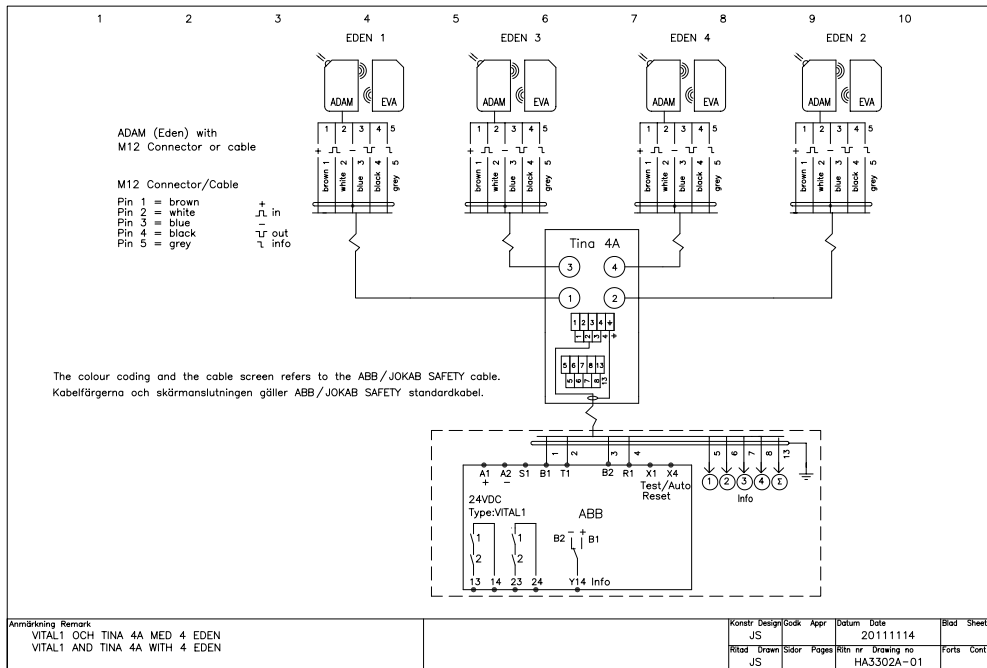

It is the user's responsibility to ensure that all control devices are correctly installed, cared for and operated to meet European, national and local codes/regulations. Subject to change without notice.

HA3302B-01 Vital 1 and 2 Tina 4A and 4 Eden and emergency stop

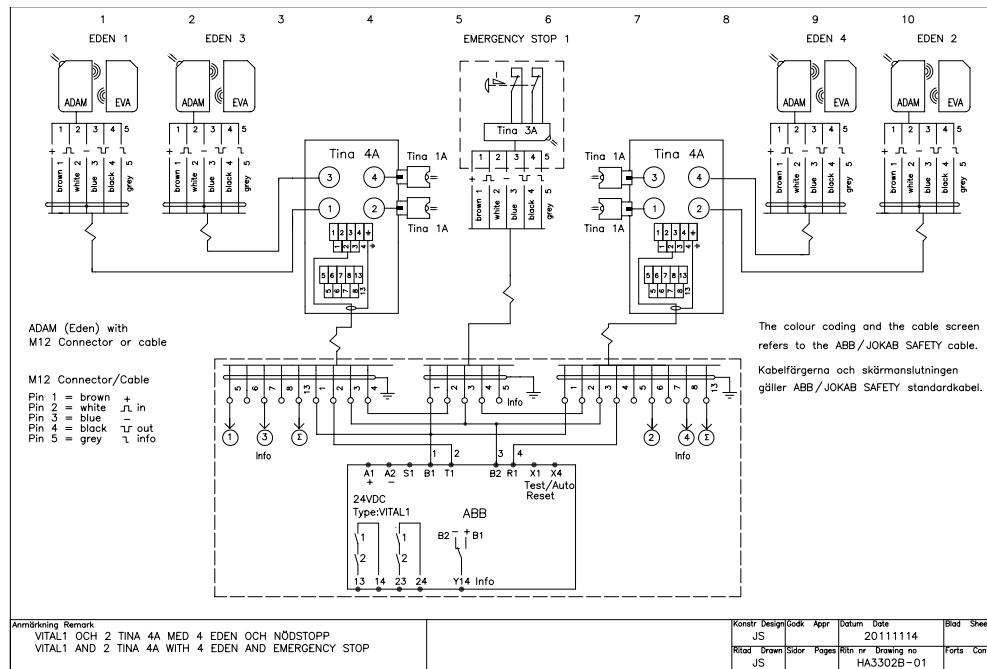

It is the user's responsibility to ensure that all control devices are correctly installed, cared for and operated to meet European, national and local codes/regulations. Subject to change without notice.

Connection examples

HA3303A Vital 1 with emergency stop/Tina 2A

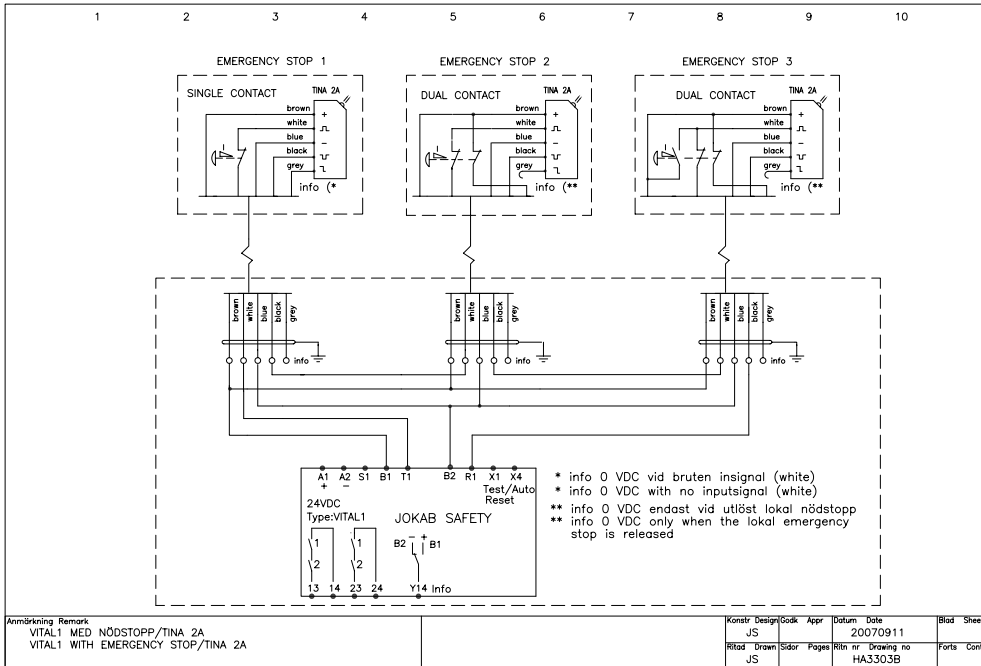

It is the user's responsibility to ensure that all control devices are correctly installed, cared for and operated to meet European, national and local codes/regulations. Subject to change without notice.

HA3304A Vital 1 with emergency stop/Tina 3A

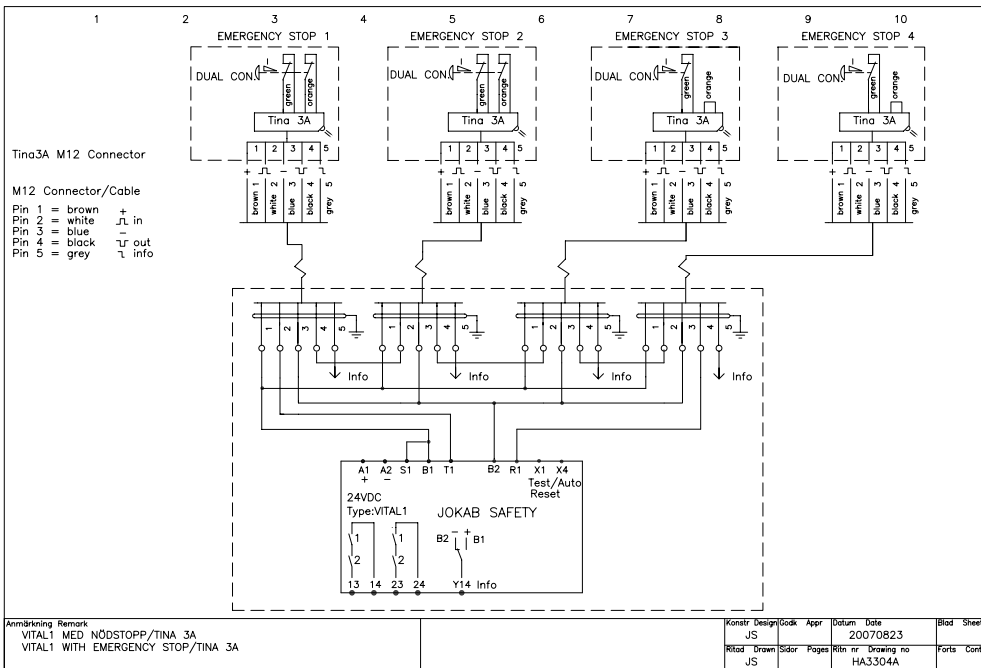

It is the user's responsibility to ensure that all control devices are correctly installed, cared for and operated to meet European, national and local codes/regulations. Subject to change without notice.

Connection examples

HA3305A Vital 1 with Eden and lightgrid Focus/Tina 10C

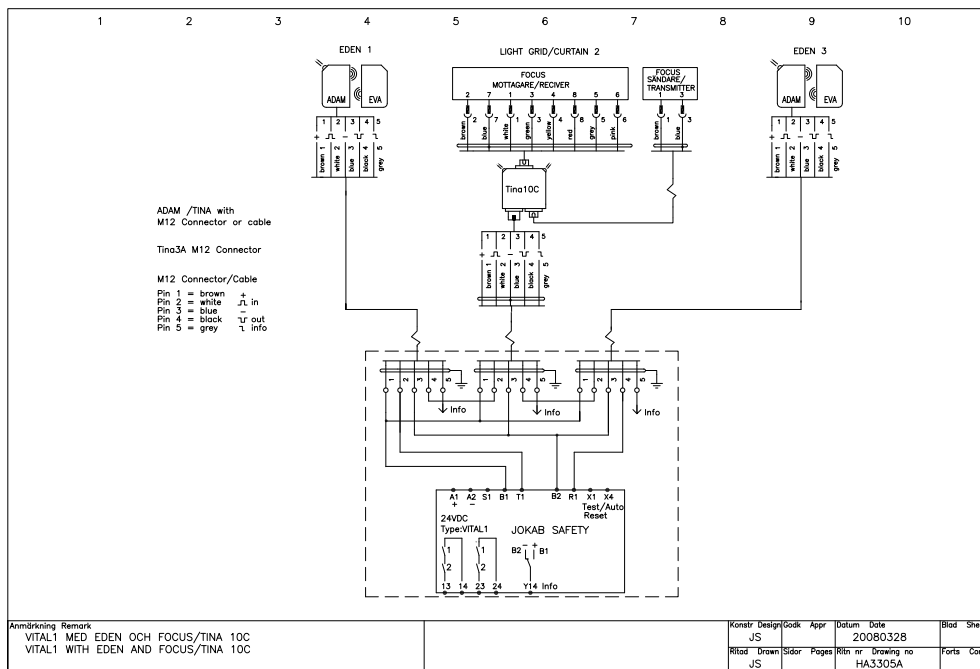

It is the user's responsibility to ensure that all control devices are correctly installed, cared for and operated to meet European, national and local codes/regulations. Subject to change without notice.

HA3304A Vital 1 with emergency stop/Tina 3A

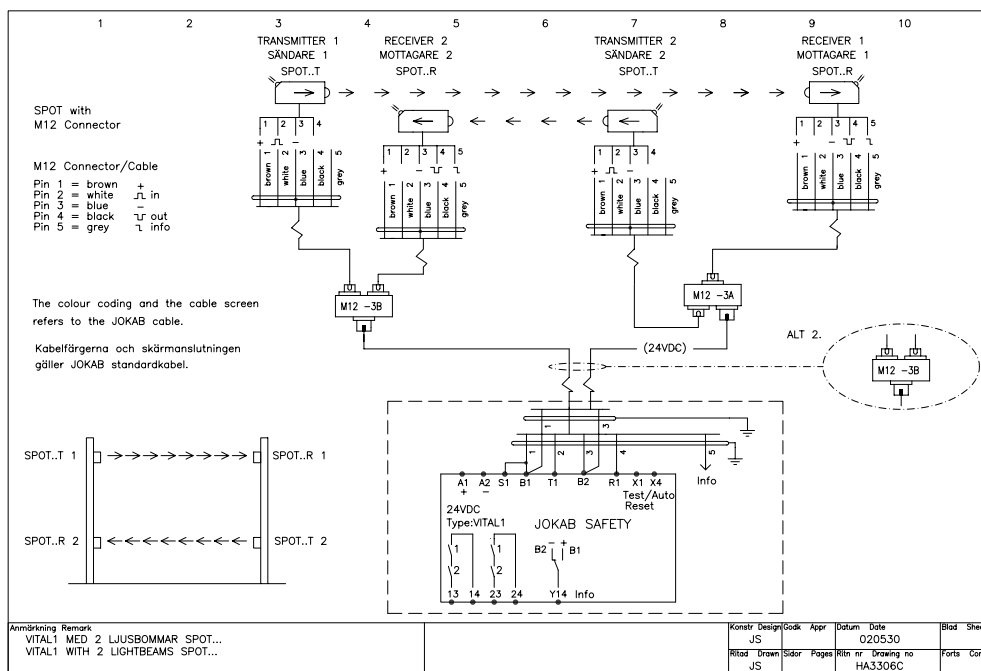

It is the user's responsibility to ensure that all control devices are correctly installed, cared for and operated to meet European, national and local codes/regulations. Subject to change without notice.

Connection examples

HA3306D Vital 1 with 3 lightbeams Spot

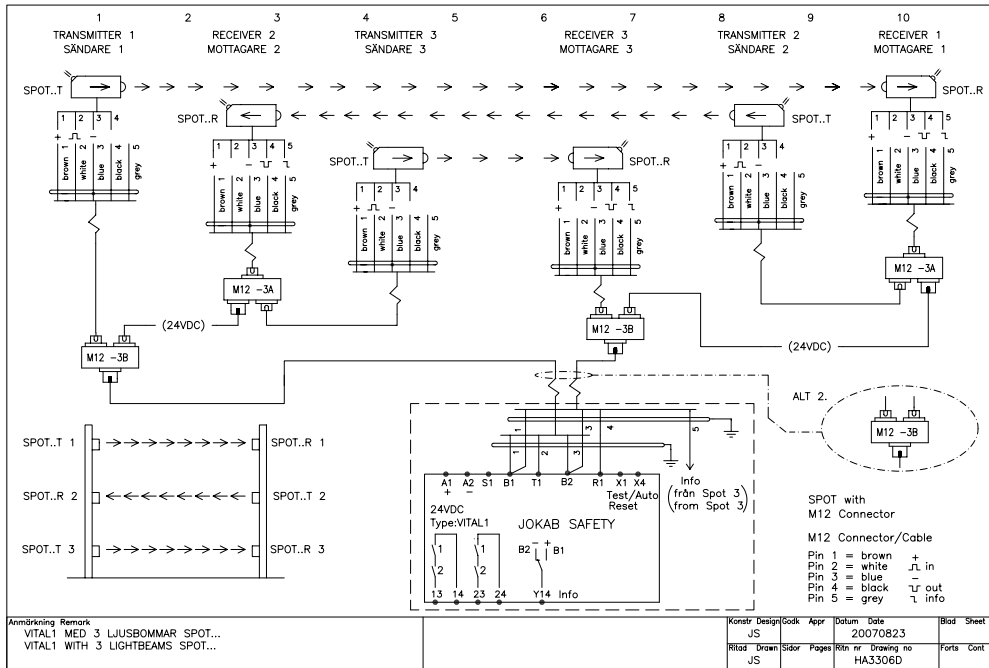

It is the user's responsibility to ensure that all control devices are correctly installed, cared for and operated to meet European, national and local codes/regulations. Subject to change without notice.

HA3307A Vital 1 with Eden, lightgrid/Tina 3A and emergency stop/Tina 7A

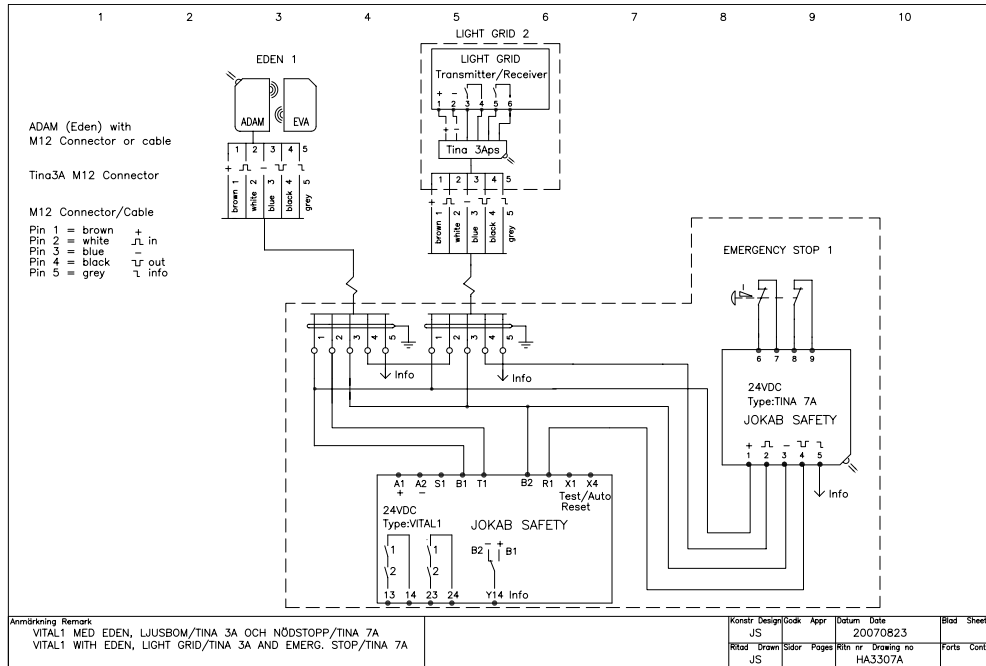

It is the user's responsibility to ensure that all control devices are correctly installed, cared for and operated to meet European, national and local codes/regulations. Subject to change without notice.

Connection examples

HD3800A-01 Vital 1 with safety light beam Spot

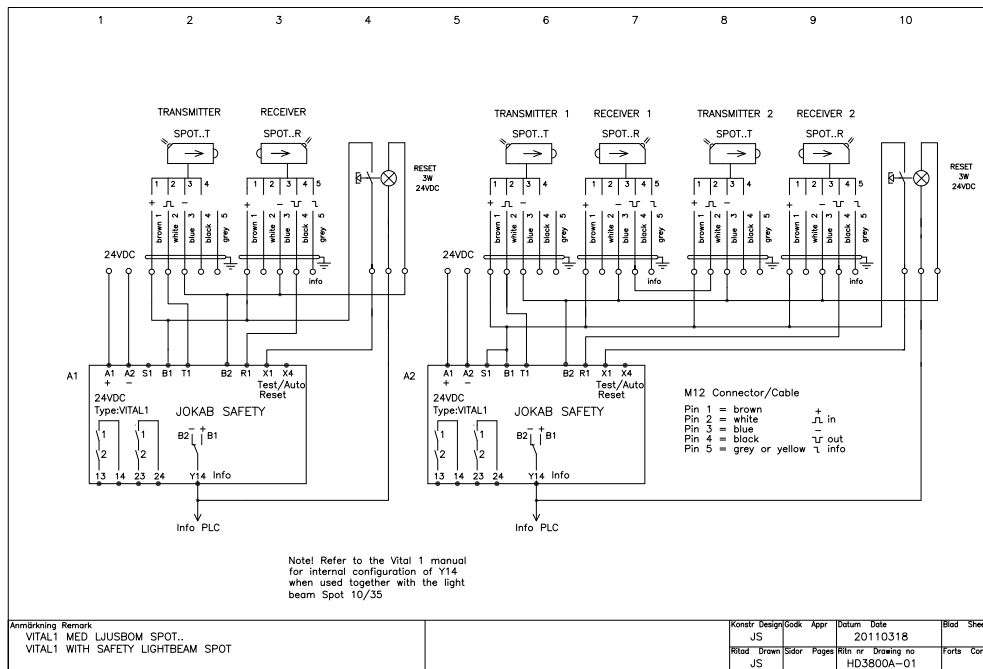

It is the user's responsibility to ensure that all control devices are correctly installed, cared for and operated to meet European, national and local codes/regulations. Subject to change without notice.

HD3801A-01 Vital 1, series and parallel

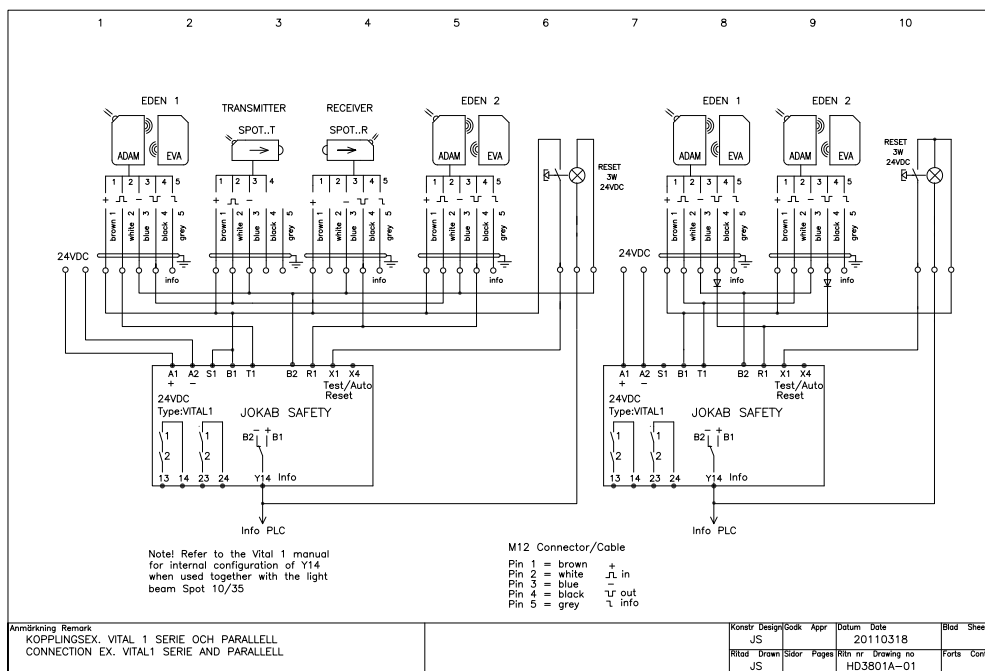

It is the user's responsibility to ensure that all control devices are correctly installed, cared for and operated to meet European, national and local codes/regulations. Subject to change without notice.

Connection examples

HE3811B-01 Safety light beam Spot with time-limited reset

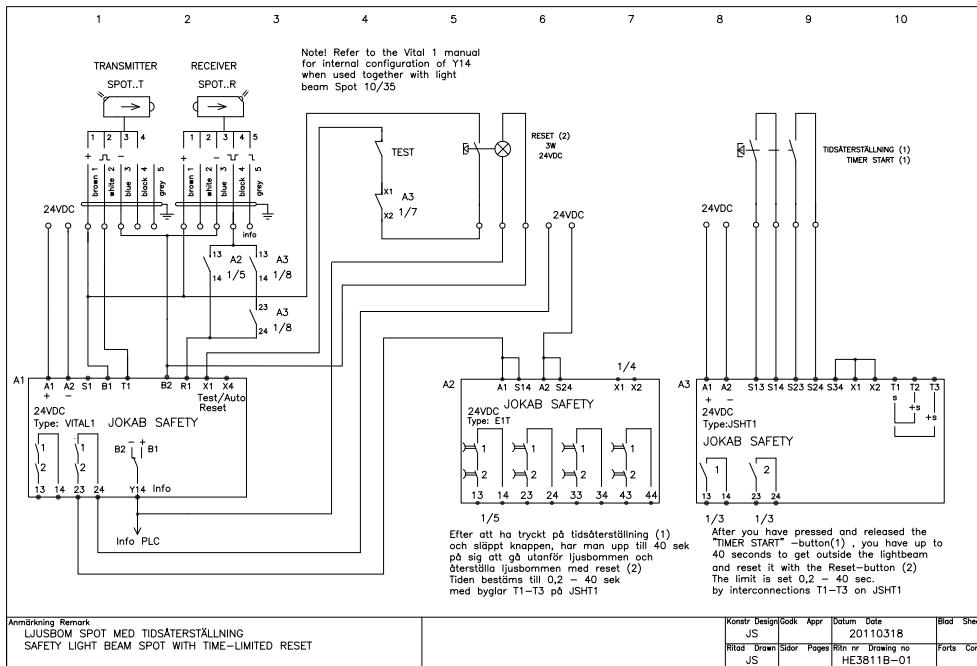

It is the user's responsibility to ensure that all control devices are correctly installed, cared for and operated to meet European, national and local codes/regulations. Subject to change without notice.

HE3824C-01 Lightbeam with time-limited bypass 0.2-40 s.

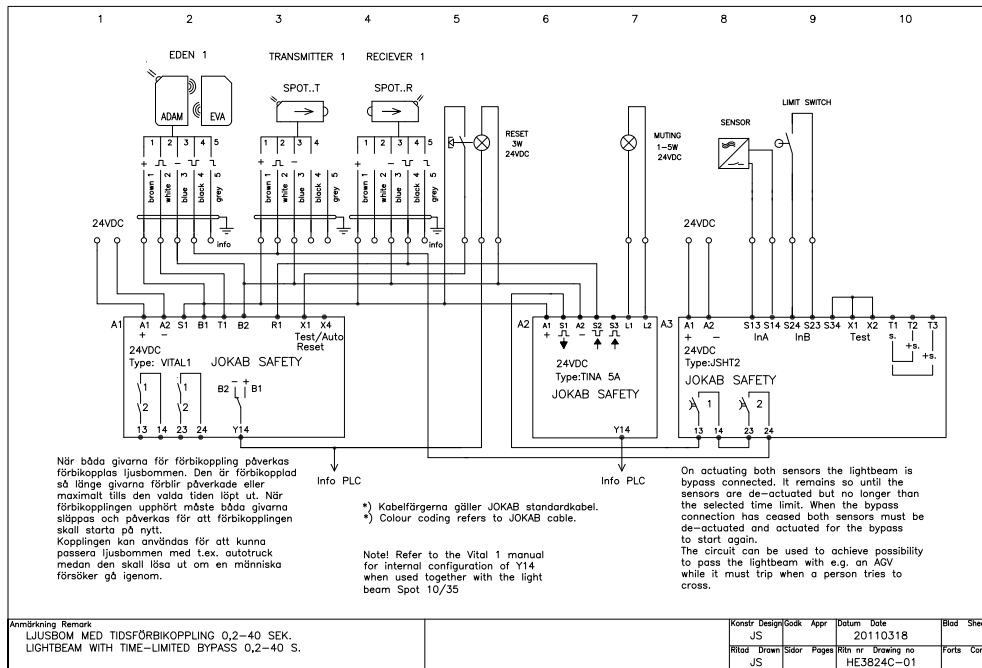

It is the user's responsibility to ensure that all control devices are correctly installed, cared for and operated to meet European, national and local codes/regulations. Subject to change without notice.

Connection examples

HE3824D-01 Eden and bypassed lightbeam with Eden

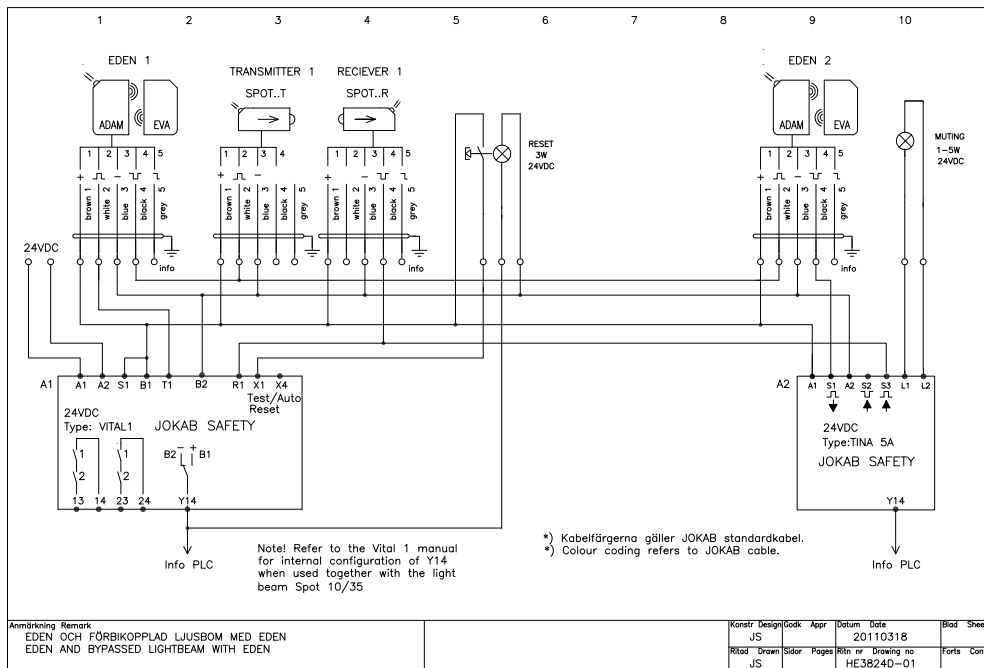

It is the user's responsibility to ensure that all control devices are correctly installed, cared for and operated to meet European, national and local codes/regulations. Subject to change without notice.

HE3824E-01 Lightbeams with time-limited bypass 0.2–40 s.

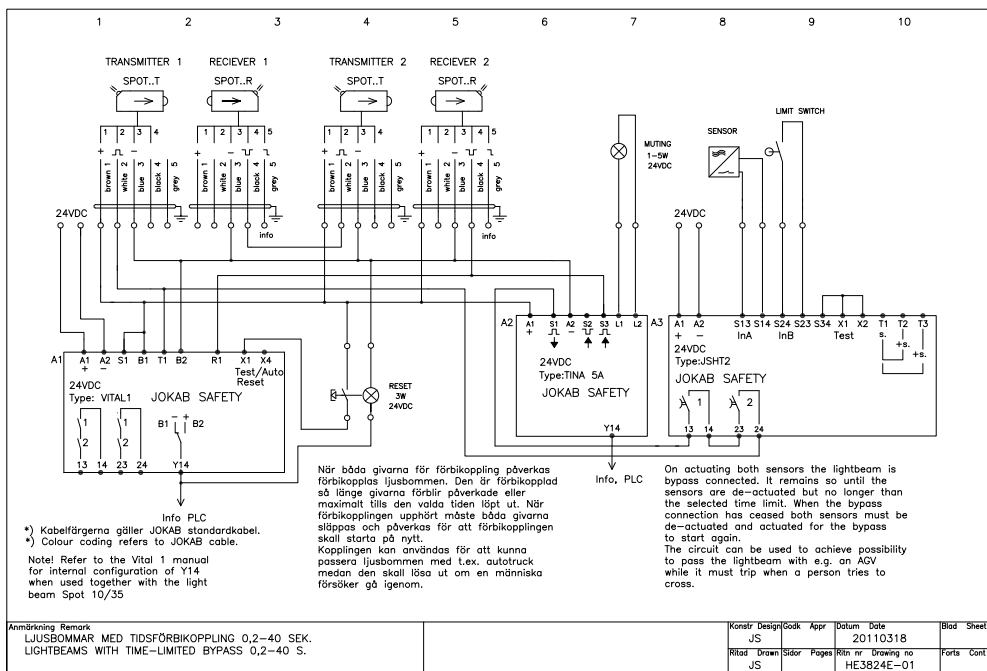

It is the user's responsibility to ensure that all control devices are correctly installed, cared for and operated to meet European, national and local codes/regulations. Subject to change without notice.

Connection examples

HE3824F-01 Eden and 2 bypass lightbeams with Eden

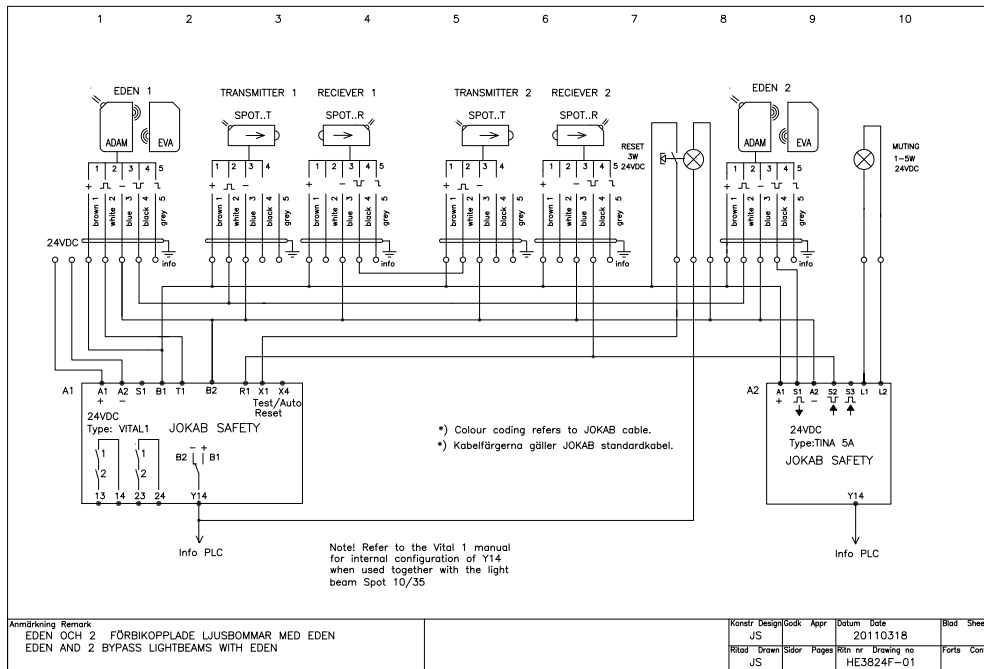

It is the user's responsibility to ensure that all control devices are correctly installed, cared for and operated to meet European, national and local codes/regulations. Subject to change without notice.

HE3824G-01 Eden and 2 separately bypassed lightbeams

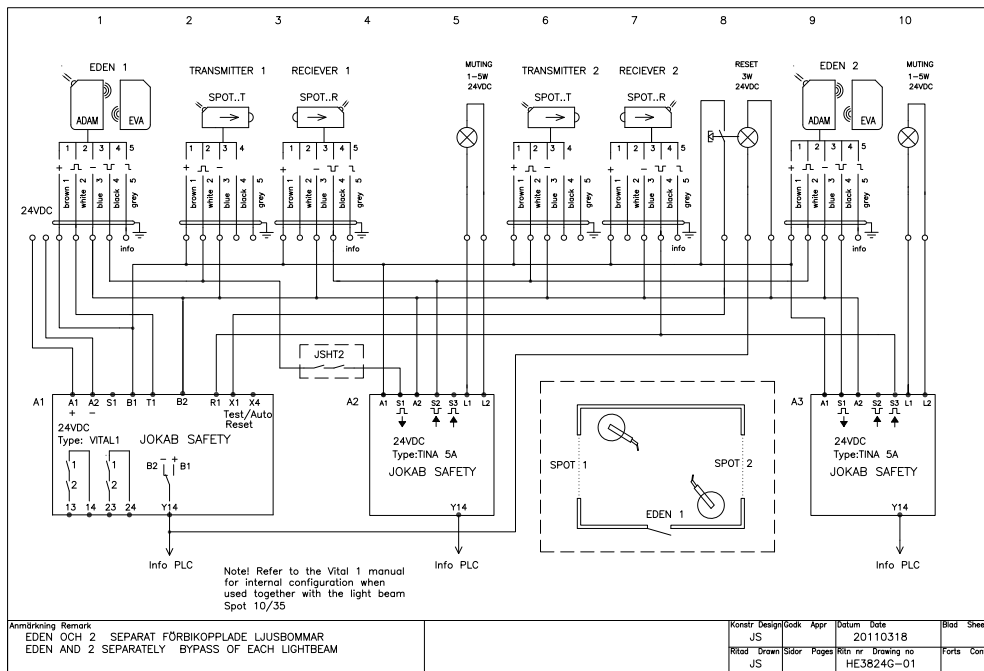

It is the user's responsibility to ensure that all control devices are correctly installed, cared for and operated to meet European, national and local codes/regulations. Subject to change without notice.

Connection examples

HH3300A Vital 1 with different types of safety devices and M12-3A

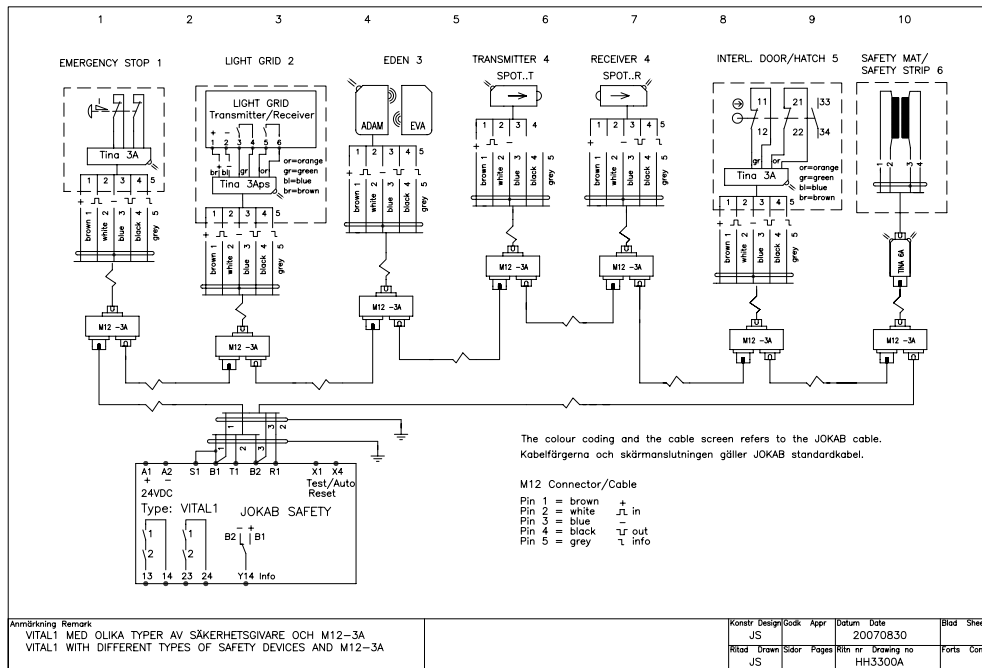

It is the user's responsibility to ensure that all control devices are correctly installed, cared for and operated to meet European, national and local codes/regulations. Subject to change without notice.

HH3300D Vital 1 with Tina 4A and different types of safety devices

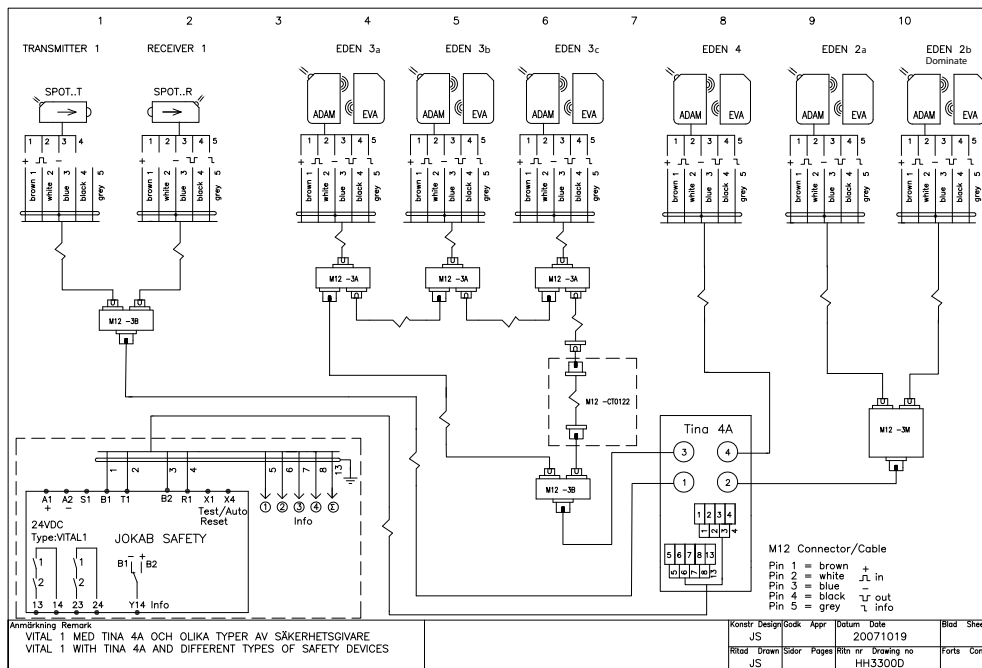

It is the user's responsibility to ensure that all control devices are correctly installed, cared for and operated to meet European, national and local codes/regulations. Subject to change without notice.

Connection examples

HH3302D-01 Vital 1 with Tina 8A and different types of safety devices

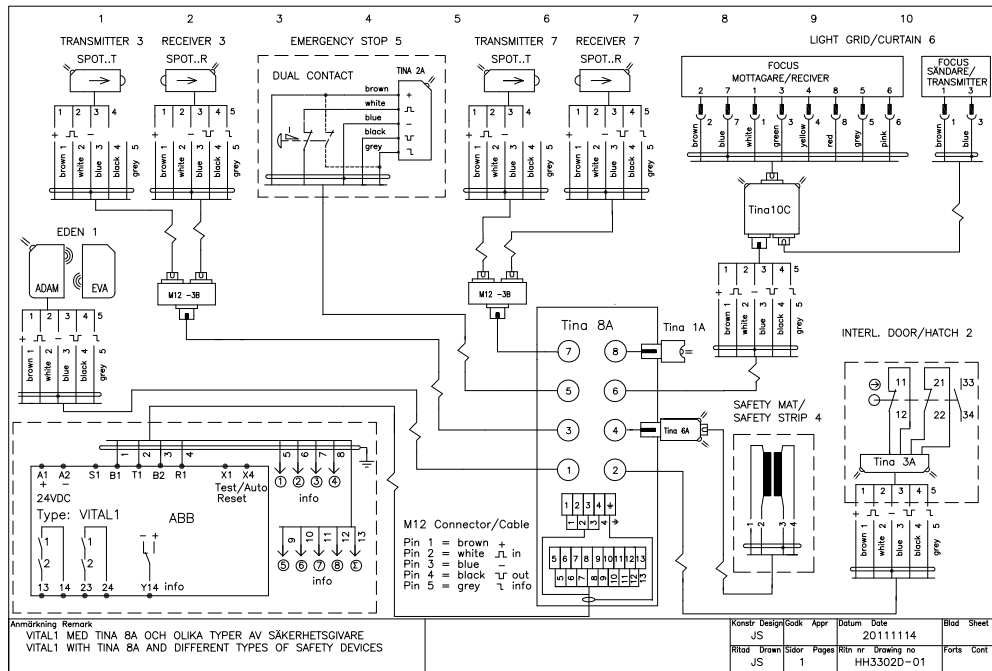

It is the user's responsibility to ensure that all control devices are correctly installed, cared for and operated to meet European, national and local codes/regulations. Subject to change without notice.

HH3301E-01 Connection example Vital 1

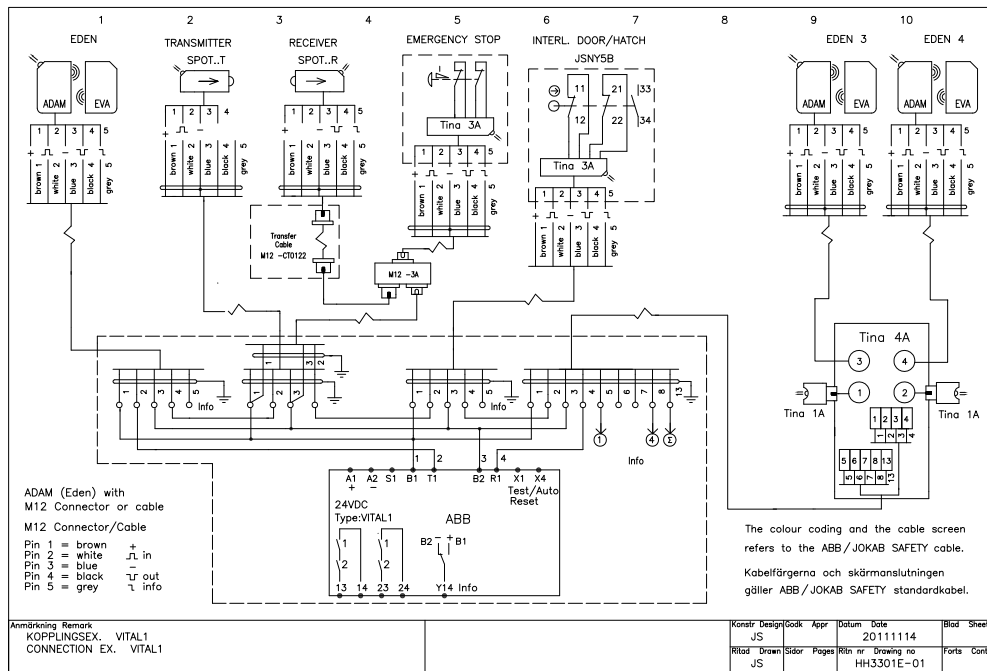

It is the user's responsibility to ensure that all control devices are correctly installed, cared for and operated to meet European, national and local codes/regulations. Subject to change without notice.

Connection examples

HH3400A2 Vital 1 Solutions

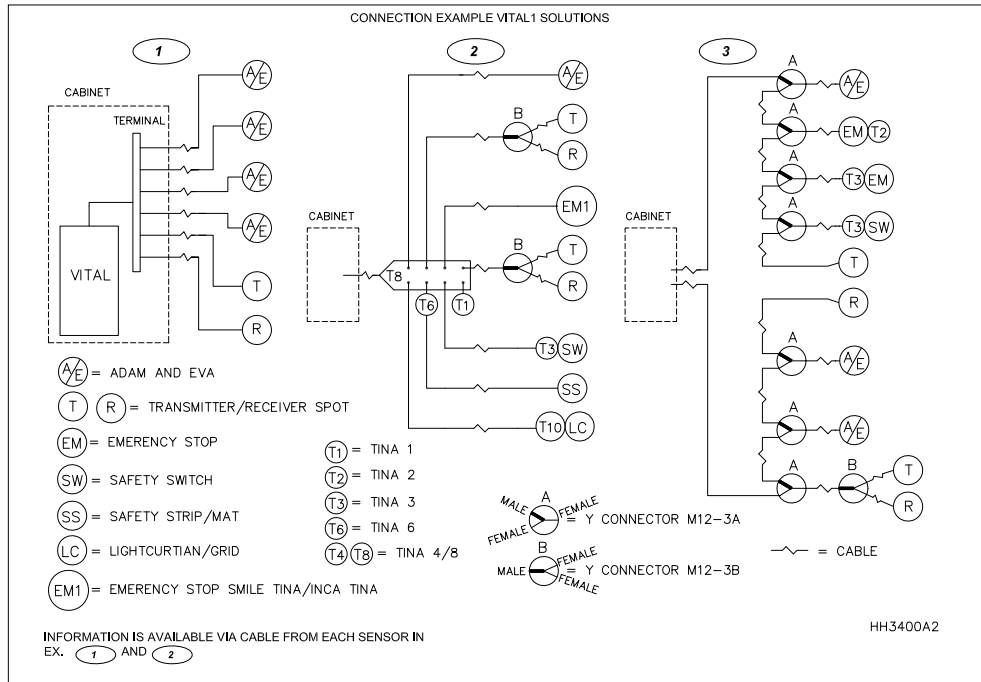

It is the user's responsibility to ensure that all control devices are correctly installed, cared for and operated to meet European, national and local codes/regulations. Subject to change without notice.

HB0005A-01 Vital with Eden and Inca emergency stop, with separate reset

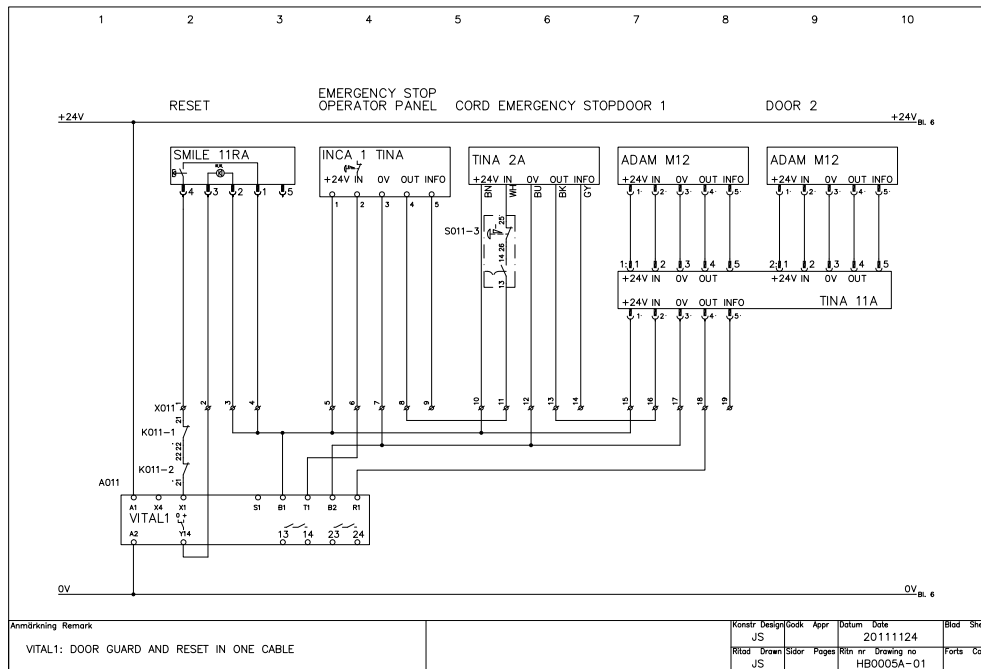

It is the user's responsibility to ensure that all control devices are correctly installed, cared for and operated to meet European, national and local codes/regulations. Subject to change without notice.

Connection examples

HB0006A-01 Vital with 4 Eden units + Reset via M12-3E and Tina 4A

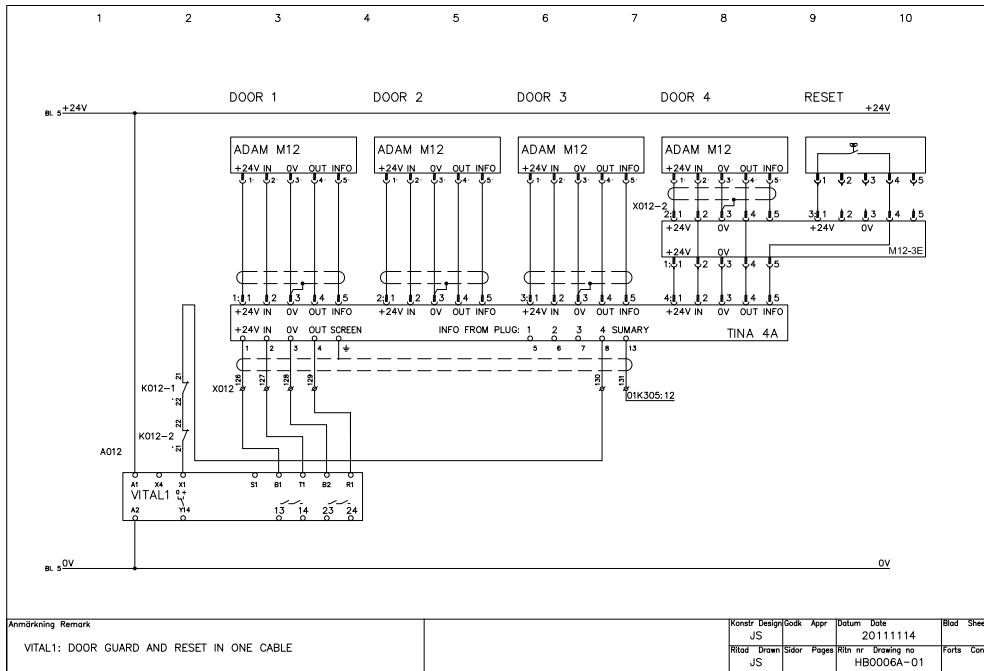

It is the user's responsibility to ensure that all control devices are correctly installed, cared for and operated to meet European, national and local codes/regulations. Subject to change without notice.

HB0007A Vital with two Dalton units via Tina 12A

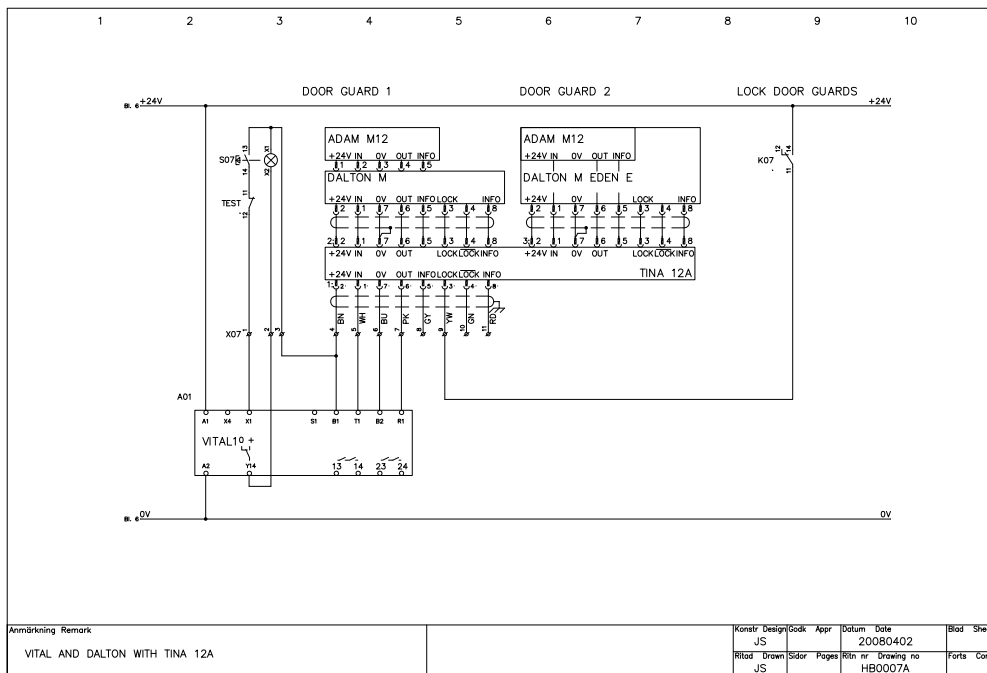

It is the user's responsibility to ensure that all control devices are correctly installed, cared for and operated to meet European, national and local codes/regulations. Subject to change without notice.

Connection examples

HB0001A-01 Pluto with Smile emergency stop unit + Reset via M12-3E and Adam via Tina

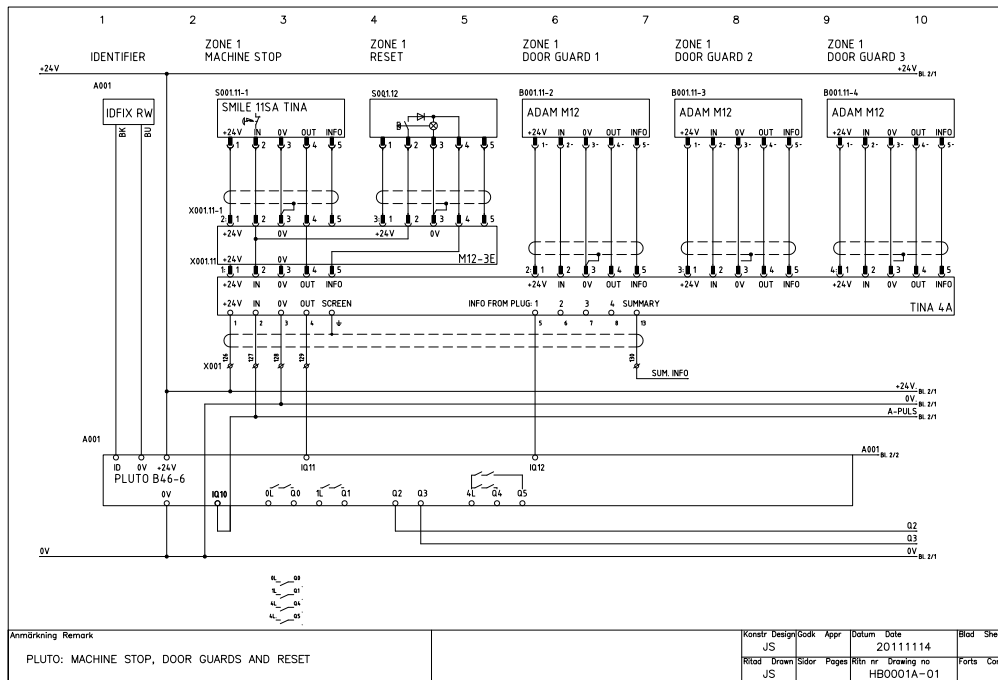

It is the user's responsibility to ensure that all control devices are correctly installed, cared for and operated to meet European, national and local codes/regulations. Subject to change without notice.

HB0002A-01 Pluto with five Eden units, for two zones via M12-3E and Tina 4A

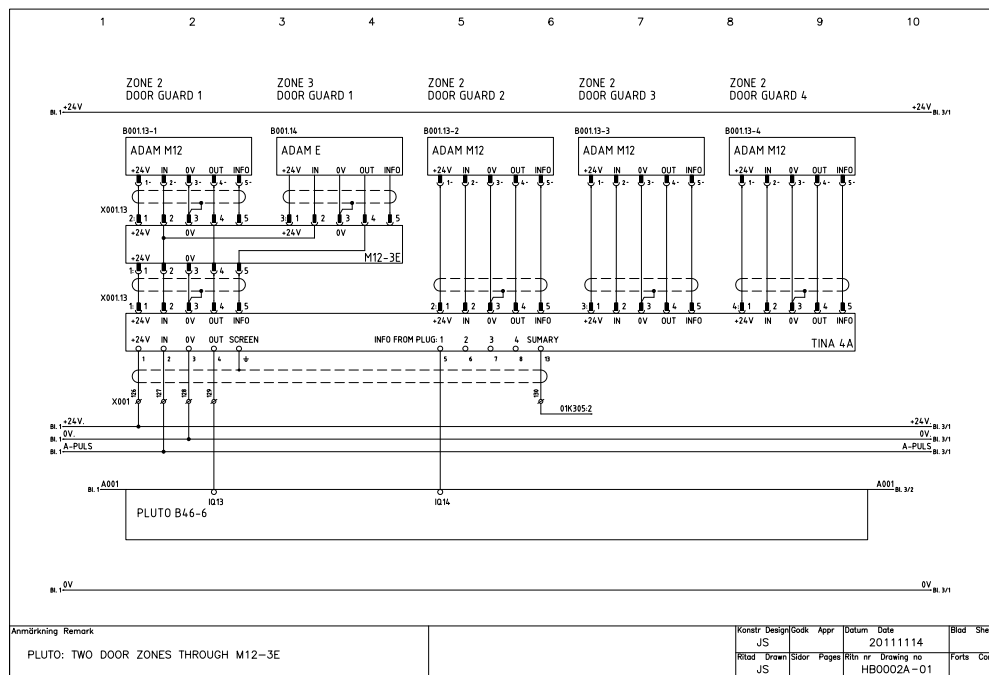

It is the user's responsibility to ensure that all control devices are correctly installed, cared for and operated to meet European, national and local codes/regulations. Subject to change without notice.

Connection examples

HB0003A-01 Pluto with Smile and Inca emergency stop units, via Tina 11A and Tina 4A

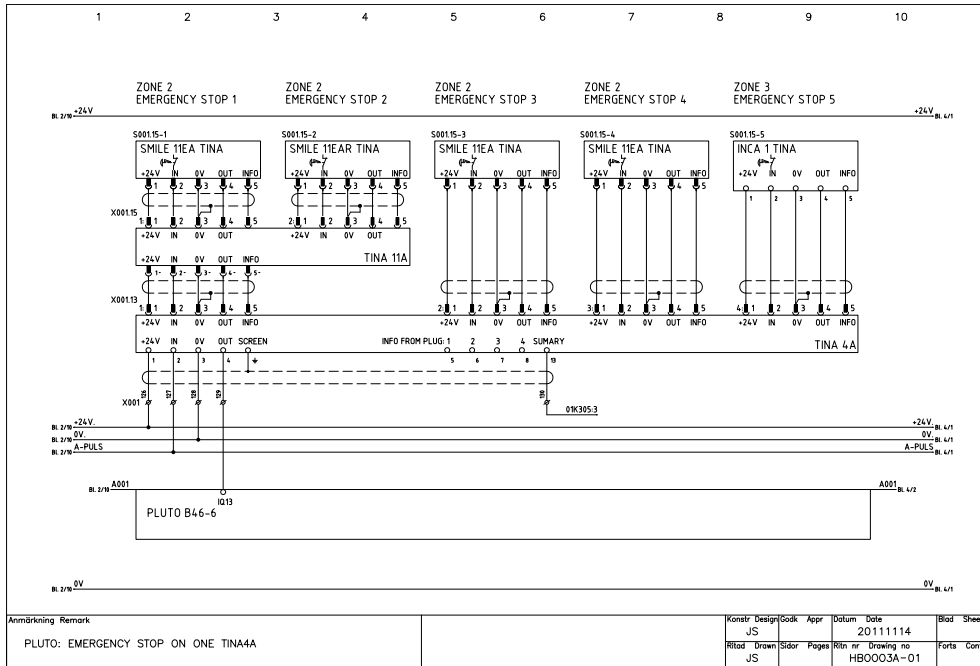

It is the user's responsibility to ensure that all control devices are correctly installed, cared for and operated to meet European, national and local codes/regulations. Subject to change without notice.

HB0004A Pluto with different zones for Eden + Reset and two Eden units +via M12-3E

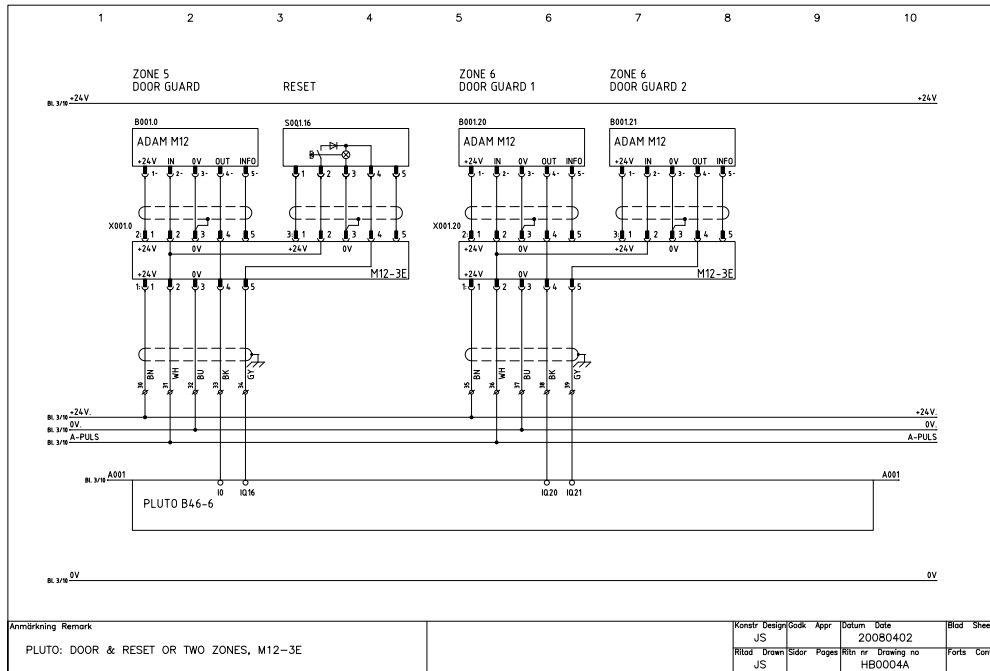

It is the user's responsibility to ensure that all control devices are correctly installed, cared for and operated to meet European, national and local codes/regulations. Subject to change without notice.

Connection examples

HH3301D-01 Connection example – Vital 1 and Tina 8A with different safety device types Tina 4A

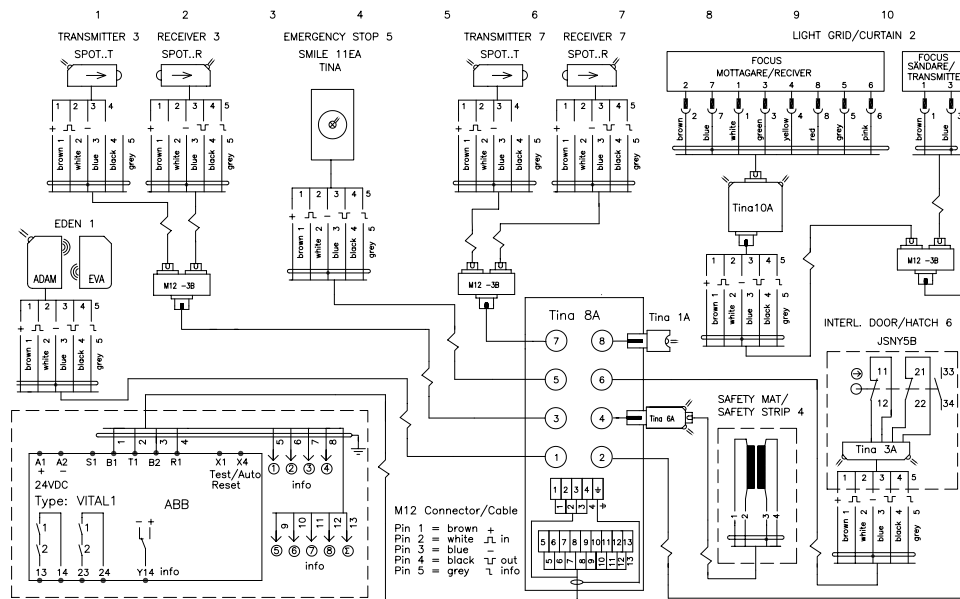

It is the user's responsibility to ensure that all control devices are correctly installed, cared for and operated to meet European, national and local codes/regulations. Subject to change without notice.



Safety Relays

Why should you use Safety relays?	6/3
The most flexible safety relays on the market!	6/4
Safety relay summary	6/5

Safety relay - RT-Series

RT6	6/7
RT7	6/11
RT9	6/15
JSBRT11	6/19

Safety relay - JSB-Series

JSBR4	6/21
JSBT4	6/23
BT50 (T)	6/25
BT51 (T)	6/27
JSBT5 (T)	6/29

Safety timers

JSHT1	6/31
JSHT2	6/33

Expansion relays

E1T	6/35
JSR1T	6/37
JSR2A	6/39
JSR3T	6/41

Connection examples	6/44
---------------------	------

Why should you use safety relays?

– to meet existing safety standards!

"A fault in the hardware or the software of the control system does not lead to hazardous situations". This is the requirement in the EU's Machinery Directive 2006/42/EC under the heading 1.2.1. Safety and reliability of control systems. The directive implies that no person should be put at risk if for example, a relay sticks or if a transistor or two electrical conductors short-circuit.

A safety relay will fulfill these requirements. A safety relay has, for example, inputs that are checked for short-circuits and

dual redundant circuits that are checked at each operation. This can be compared to the dual brake circuits in a car. If one of the circuits is faulty the other will stop the car. In a safety relay there is an additional function which only allows a machine to start if both circuits are ok.

The standard for safety related parts of the control system describes various safety categories depending on the level of risk and application. One single universal relay with selectable safety categories solves this.

– to supervise safety devices!

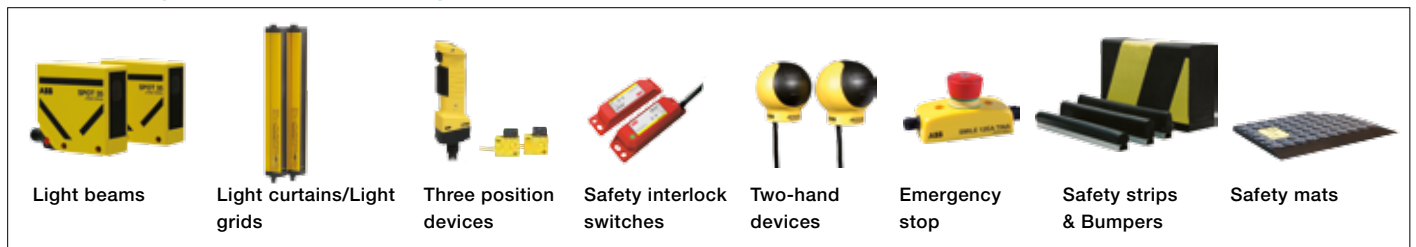

– for safe stops and reliable restarts!

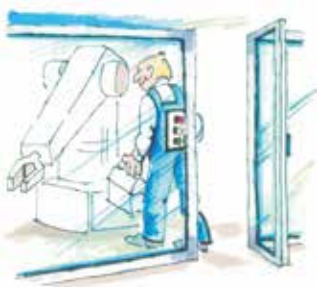

Dual stop signals when the gate is opened.

Entering or putting a hand or limb into a hazardous area must cause all machinery that can cause personal injury to stop safely. Many serious accidents occur when machinery is believed to have stopped but is in fact only pausing in its program sequence. The safety relay monitors the gate interlock switch and cables and gives dual stop signals.



Supervised reset when there can be a person within the risk area.

To make sure that nobody is within the restricted area when activating the reset button. A supervised reset button must be pressed and released before a reset can occur. Many serious accidents have been caused by an unintentional and unsupervised reset.



Timed reset when you cannot see the entire risk area.

Sometimes a double reset function is necessary to make sure that no one is left behind in the risk area. First, after ensuring no other person is inside the hazardous area, the pre-reset button must be activated, followed by the reset button outside the risk area within an acceptable time period e.g 10 seconds. A safety timer and a safety relay can provide this function.



Automatic reset for small hatches.

Where body entry is not possible through a hatch, the safety circuit can be automatically reset.

The safety relays are reset immediately when the hatch interlock switch contacts are closed.

The most flexible safety relays on the market!

We have the most flexible safety relays on the market. Our first universal relay was developed in 1988. Nowadays, the flexibility is even greater and size has been reduced by 85 %.

A universal relay is a safety relay with various input options for various safety devices and risk levels.

Internally, the safety relay is of the highest safety level (PL e according to EN ISO 13849-1). A machine supplier can therefore, with one single safety relay, select the input configuration that best suits their customers' safety requirements. In addition, our safety relays have detachable connector blocks for ease of replacement and testing. As our universal relays incorporate all input options, they are compatible with all our previous safety relays as well as with other manufacturers' products.

Is a universal relay expensive? No, our latest patented construction is extremely simple and the number of major components is less compared to our previous universal relays. This means that the safety relays are even more reliable than before.

We also have a great deal of experience from safety solutions in our own system developments. It would be our pleasure to share these experiences with you! Please see the complete safety solutions in the section "Connection examples". Please do not hesitate to contact us if you should require any other safety solutions.

Some of the advantages with ABB Jokab Safety's safety relays

- Universal relays
- Excellent reliability
- Approved in Europe, USA, Canada
- Supervised reset
- Time reset
- Small and compact
- Detachable connector blocks
- Low power consumption
- Permits the use of long emergency stop cables
- EX compatibility
- Functions set by external hardwired links
- LED indication for inputs and outputs
- Powerful switching capacity

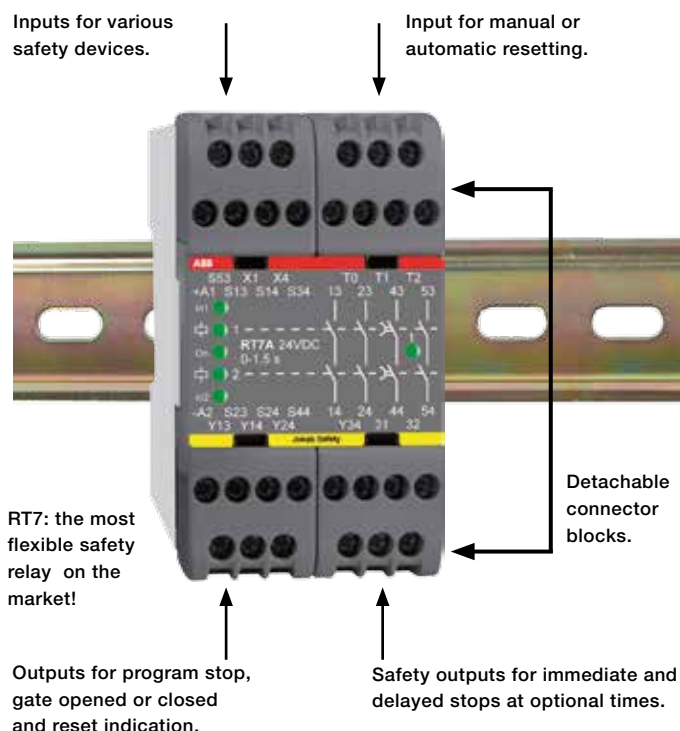

Summary Safety Relays

Which safety relay should you choose?

First of all, we would recommend the selection of one of our latest universal relays in the RT-series. These are both practical and cost effective.

To facilitate the choice of safety relay or combinations of safety relays, please see:

- the table below dividing the safety relays into application fields
- the table on the opposite page showing possible input and output options
- the relevant data sheet giving comprehensive information about each specific safety relay
- the circuit diagram for various applications in the section “Connection examples”.

Note! All earlier types of relays that can now be replaced by those in this manual are still kept as stock items and can be supplied upon request.

Application fields

	Safety relays									Safety timers		Expansion relays			
	RT6	RT7	RT9	JSBRT11	JSBR4	JSBT4	JSBT5T, BT50T, BT51T	JSBT5, BT50, BT51	JSH11A/B	JSH22A/B/C	E1T	JSR1T	JSR2A	JSR3T	
Interlocking switch/Gate/Hatch	●	●	●	●	●	●	●	●							
Light curtains	●	●	●	●											
Light beams	●	●	●	●											
Safety mats	●	●	●		●	●									
Contact strips	●	●	●		●	●									
Two-hand control device					●										
Emergency stop	●	●	●	●	●	●	●	●							
Hold to run/enabling device	●	●	●	●	●	●				●					
Foot control device	●	●	●	●	●	●				●					
Area supervision	●	●	●	●	●	●									
Time resetting									●						
Time bypassing									●	●					
Inching										●					
Output expansion	●	●	●	●		●	●	●			●	●	●		
Delayed output		●					●				●	●		●	

Input alternatives (see also technical data on the next page)

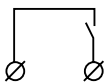

Single-channel, 1 NO from +24 V
Category 1, up to PL c

The input must be closed before the outputs can be activated. A stop signal is given when the input is opened.

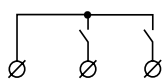

Two-channel, 2 NO from +24 V
Category 3, up to PL d

Both the inputs must be closed before the outputs can be activated. A stop signal is given if one or both of the inputs are opened. Both the inputs must be opened and reclosed before the outputs can be reactivated. A short-circuit between the inputs is not monitored by the safety relay. Category 4 can only be achieved if a safety device with short circuit monitored outputs is connected.

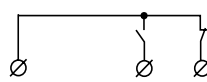

Two-channel, 1 NO & 1 NC from +24V
Category 4, up to PL e

One input must be closed and one must be opened before the outputs can be activated. A stop signal is given if one or both of the inputs change position or if the inputs short-circuit. Both inputs must be put into their initial position before the outputs can be reactivated.

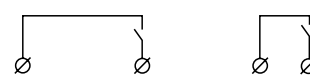

Two-channel, 1 NO from 0 V & Category 4, up to PL e

Both the inputs must be closed before the outputs can be activated. A stop signal is given if one or both of the inputs are opened. Both the inputs must be opened and reclosed before the outputs can be reactivated. A Stop signal is given if there is a short-circuit between the inputs.

Technical data

	Safety relays											Safety timers		Expansion relays			
	RT6	RT7	RT9	JSBRT11	JSBR4	JSBT4	JSBT5T	BT50T	BT51T	BT50	BT51	JSHT1A/B	JSHT2A/B/C	E1T	JSR1T	JSR2A	JSR3T
Safety category	1-4	1-4	1-4	1-4	4	4	1-4°	1-4°	1-4°	1-4°	1-4°	1-4	1-4	1-4	1-4	1-4	1-4
Safety input																	
Single-channel, 1 NO from +24 V	●	●	●	●			●	●	●	●	●	●	●	●	●	●	●
Two-channel, 2 NO from +24 V	●	●	●	●													
Two-channel, 1 NO & 1 NC from +24 V	●	●	●	●													
Two-channel, 1 NO from 0 V & 1 NO from +24 V	●	●	●	●	●	●						●	●	●	●	●	●
Contact strips/Safety mats	●	●	●		●	●											
Reset & test input																	
Monitored manual	●	●	●	●	●	●											
Automatic/Unmonitored manual	●	●	●	●		●	●	●	●	●	●						
Testing of contactors, relays, valves, etc.	●	●	●	●	●	●	●	●	●	●	●	●					
Output																	
NO	3	2	2	7	3	3				3	4			4*	4*	4	
NO delayable		2					3 [†]	3	4					4*	4*		2°
NO impulse outputs												2°	2°				
NC info	1	1		2	1	1				1					1*	1	
NC info delayable							1 [†]	1							1*		
Info. output	2	3	1					1	1								
Switching capacity (resistive load)	4	3	2	9	4	4	4	4 [‡]	4 [‡]	4	4			4	5		
6A/250VAC/1500VA/150W												2°	2°				2°
4A/250VAC/1000VA/100W		2 [‡]															
6A/250VAC/1380VA/138W																5	
Width (mm) 10A/250VAC/1840VA/192W	45	45	22.5	100	45	45	22.5	22.5	22.5	22.5	22.5	45	45	22.5	45	45	22.5
Supply voltage																	
12VDC							●										
24VDC	●	●	●	●	●	●	●	●	●	●	●	●	●	●	●	●	●
24VAC	●						●									●	●
115VAC	●	●		●	●											●	
230VAC	●	●		●	●											●	

* Indicates the possibility of selecting delayed outputs □ Indicates one relay contact per output (other relays having two contacts per output)
[‡] delay-able ° Category 4 depending on connection (When used as expansion relay with Pluto Safety PLC, then Category 4) † fixed 0.5 s delay

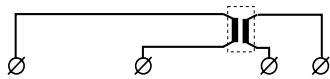

Contact strips/Safety mats
Category 3, up to PL d

For an unpressurised mat/strip, both the relay inputs must be closed for the outputs to be activated. In the case of an activated mat/strip and short-circuit input channels, the relay will be de-energized. Current limitation prevents the safety relay from being overloaded when the channels short-circuit.

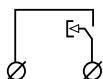

Monitored manual reset

A monitored reset means that the safety relay will not be reset if the reset button gets jammed when pressed in or if the input short-circuits. In order for the resetting to be complete, the input must be closed and opened before the outputs can close.

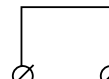

Automatic/unmonitored manual reset

Automatic reset means that the outputs are closed immediately when both the input conditions are satisfied and the test input is closed.

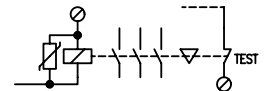

Testing of contactors, relays & valves

Can be carried out with both automatic and manual reset.

Safety relay RT6



Approvals:



Safety relay for:

- Emergency stops
- Light curtains
- Three position devices
- Interlocked gates/hatches
- Magnetic switches
- Light beams
- Safety mats
- Contact strips
- Foot operated switches

Features:

- Five input options
- Single or dual channel input
- Manual supervised or automatic reset
- Test input for supervision of external contactors
- Width 45 mm
- LED indication of supply, inputs, outputs, short-circuit and low voltage level.
- 3 NO/1 NC relay outputs
- Two voltage free transistor information outputs
- Supply 24 VDC, 24, 115 or 230 VAC
- Quick release connector blocks

6

Would you like a single safety relay for all your safety applications?

Then choose the RT6 universal relay to supervise both your safety devices and the internal safety of your machinery. In addition you can select the safety level required for each installation. All this is possible because the RT6 has the most versatile input option arrangement available on the market. Many other relays can therefore be replaced by the RT6.

The relay also comes with other options such as manual or automatic reset. Manual supervised reset can be used for gates and other safety devices that can be bypassed. Automatic reset can be used for small hatches, if deemed acceptable from risk assessment.

The RT6 also has information outputs that follow the inputs and outputs of the relay. These outputs will for example indicate if a gate is open or closed and if the safety relay needs to be reset.

The RT6 is designed with a minimum amount of components thus keeping both production costs and component acquisitions to a minimum.

Choose the RT6 to simplify your safety circuits and reduce your costs.

RT6

Technical information

Inputs

The inputs from the safety devices must be connected according to one of the following options in order to fulfill the expected safety level and to avoid unsafe situations.

1. Single channel, 1NO contact from +24 VDC, category 1, up to PL c
2. Dual channel, 2NO contacts from +24 VDC, category 3, up to PL d
3. Dual channel 1NO, 1 NC contact from +24 VDC, category 4, up to PL e
4. Dual channel, 1NO contact from 0V and 1NO contact from +24 VDC, category 4, up to PL e
5. Safety mats/contact strips 1 'contact' from 0V and 1 'contact' from +24 VDC, category 3, up to PL d

When the input/inputs are activated and the test/supervised reset is complete, relays 1 and 2 are energized. Simultaneous activation is not required where there are dual channels. The two relays are de-energized when the input/inputs are de-activated in accordance with the input option chosen or in case of a power failure. Relays 1 and 2 must both be de-energized before the outputs can be activated again.

Transistor output status information

The RT6 has two voltage free transistor outputs that can be connected to a PLC, computer or other monitoring device. These outputs give the input and output status of the relay.

Reset and testing

The RT6 has two reset options; manual and automatic. The manual supervised reset is used when the RT6 is monitoring safety devices that can be bypassed, i.e. to ensure that the outputs of the safety relay do not close just because a gate is closed. The automatic reset should only be used if deemed an acceptable risk.

In addition, the RT6 can also test (supervise) whether, for example, contactors and valves etc are de-energized/de-activated before a restart is allowed.

Indication of low voltage

The 'On' LED will flash if the relay supply voltage falls below an acceptable level. This indication will also be given if a monitored safety mat/contact strip is actuated. See connection option 5.

Safety level

The RT6 has internal dual and supervised safety functions. A short-circuit, internal faulty component or external interference will not present a risk to options with the highest safety level. A manual reset requires that the reset input is closed and opened before the safety relay outputs are activated. A short-circuit or a faulty reset button is consequently supervised.

When the RT6 is configured for dual channel input, both the inputs are supervised for correct sequence operation before the unit can be reset.

The input options 3 and 4 have the highest safety levels as all short-circuits and power failures are supervised. This in combination with internal current limitation makes the relay ideal for supervision of safety mats and contact strips.

Regulations and standards

The RT6 is designed and approved in accordance with appropriate directives and standards. See technical data.

Connection examples

For examples of how our safety relays can solve various safety problems, see the section "Connection examples".

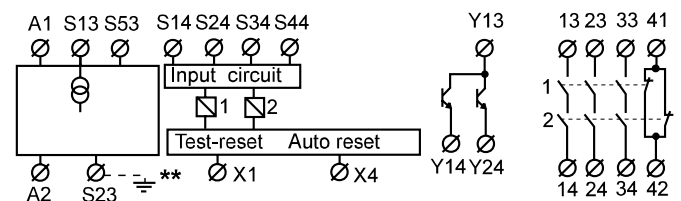

**Only for AC supply

Connection of supply - RT6

DC supply

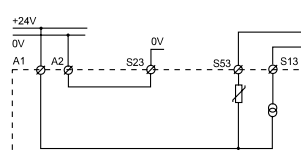

The RT6 DC option should be supplied with +24 V on A1 and 0 V on A2.

AC supply

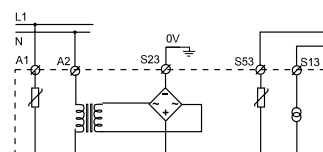

The RT6 AC option should be supplied with the appropriate supply voltage via connections A1 and A2. The S23/⏏ must be connected to protective earth.

DC-supply of AC-units

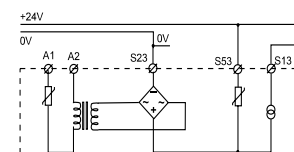

All AC-units can also be supplied by +24 VDC to S53 (0VDC to S23).

NOTE! With both DC and AC modules, if cable shielding is used this must be connected to an earth rail or an equivalent earth point.

Connection of safety devices - RT6

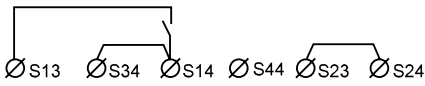

1. SINGLE CHANNEL, 1 NO from +24V

The input (contact to S14) must be closed before the outputs can be activated. When the input contact is opened the relay safety output contacts open.

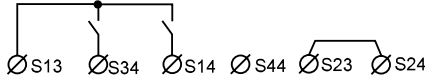

2. DUAL CHANNEL, 2 NO from +24V

Both input contacts (S14 and S34) must be closed before the relay outputs can be activated. The safety relay contacts will open if one or both of the input contacts are opened. Both the input contacts must be opened and reclosed before the relay can be reset. A short-circuit between inputs S14 and S34 can only be supervised if the device connected to the inputs has JOKAB Focus light curtains.

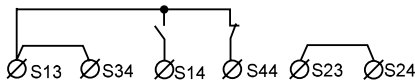

3. DUAL CHANNEL, 1 NO, 1 NC from +24V

One input contact must be closed (S14) and one opened (S44) before the relay outputs can be activated. The safety relay contacts will open if one or both of the inputs change state or in case of a short-circuit between S14 and S44. Both inputs must return to their initial positions before the relay outputs can be reactivated. Both 'contact' inputs from an inactivated safety mat/contact strip must be made in order to allow the RT6 relay outputs to be activated. When the safety mat/contact strip is activa

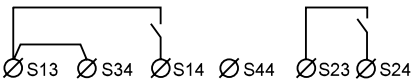

4. DUAL CHANNEL, 1 NO from +24V, 1 NO to 0V

Relay functions as for option 2, but a short-circuit, in this case between inputs S14 and S24, is supervised (safety outputs are opened).

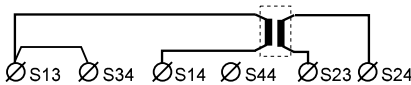

5. Safety mat/Contact strip

Both 'contact' inputs from an inactivated safety mat/contact strip must be made in order to allow the RT6 relay outputs to be activated. When the safety mat/contact strip is activated or a short-circuit is detected across S14-S23, the relay will de-energize (safety outputs open) and the 'ON' LED will flash. As output S13 has an internal current limit of 70 mA, the RT6 will not be overloaded when the mat/contact strip is activated or a short-circuit is detected

6

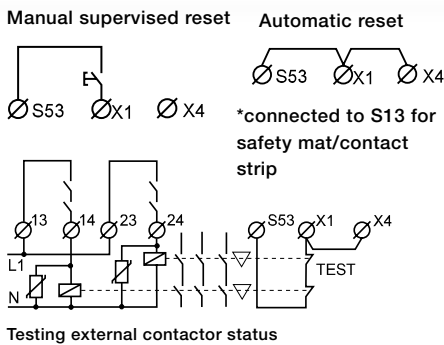

Reset connections - RT6

The manual supervised reset contact connected to input X1 must be closed and opened in order to activate the relay outputs

Automatic reset is selected when S53, X1 and X4 are linked. The relay outputs are then activated at the same time as the inputs.

Contactors, relays and valves can be supervised by connecting 'test' contacts between S53 and X1. Both manual supervised and automatic reset can be used.

Relay outputs

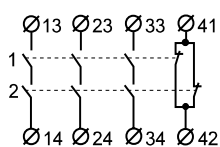

Transistor outputs

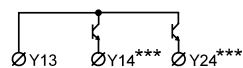

***Note These outputs are only for information purposes and must not be connected to the safety circuits of the machinery.

Output connections - RT6

The RT6 has three (3 NO) safety outputs and 1 NC information output.

In order to protect the output contacts it is recommended that loads (inductive) are suppressed by fitting correctly chosen VDR's, diodes etc.

Diodes are the best arc suppressors, but will increase the switch off time of the load.

The RT6 has two(2) voltage free transistor outputs for information.

The transistor outputs are supplied with voltage to Y13, either from S53 (+24V) or an external 5-30 VDC supply. Y14 and Y24 follow the relay inputs and outputs as follows:

- Y14 becomes conductive when the relay input conditions are fulfilled.
- Y24 becomes conductive when both the output relays are activated.

Technical data - RT6

Article number	
RT6 24 VDC	2TLA010026R0000
RT6 24 VAC	2TLA010026R0200
RT6 48 VAC	2TLJ010026R0300
RT6 115 VAC	2TLA010026R0400
RT6 230 VAC	2TLA010026R0500
Colour	
	Grey
Weight	
	335 g (24 VDC) 485 g (24-230 VAC)
Supply	
Voltage (A1-A2)	24 VDC +15/-20%, 24/115/230 VAC, +15/-10%, 50-60 Hz
Power consumption	
DC supply, nominal voltage	2.3 W
AC supply, nominal voltage	5.2 VA
Connection S13 Short-circuit protected voltage output, 70 mA ± 10% current limitation. Is used for the inputs S14, S34 and S44.	
Connection S53 Short-circuit protected voltage output, internal automatic fuse 270 mA. Is used for the reset and autoreset inputs X1 and X4	
Connection S23 OV connection for input S24	
Safety inputs	
S14 (+) input	20 mA
S24 (OV) input	20 mA
S34 (+) input	20 mA
S44 (+) input	30 mA
Reset input X1	
Supply for reset input	+ 24 VDC
Reset current	300 mA current pulse at contact, then 30 mA
Minimum contact closure time for reset	100 ms
Maximum external connection cable resistance at nominal voltage for	
S14, S24, S34	300 Ohm
S44, X1	150 Ohm
Response time	
At Power on DC/AC	<90ms/<220ms
When activating (input-output)	<20 ms
When deactivating (input-output)	<20 ms
At Power Loss	<150 ms
Relay outputs	
NO	3
NC	1
Maximum switching capacity	
Resistive load AC	6A/250 VAC/1500 VA
Inductive load AC	AC15 240 VAC 2A
Resistive load DC	6A/24 VDC/150 W
Inductive load DC	DC13 24 VDC 1A
Maximum total switching capacity	
Resistive load	12A distributed on all contacts
Minimum load	10mA/10 V (if load on contact has not exceeded 100 mA)
Contact material	Ag+Au flash
Fuses Output (External)	5A gL/gG
Conditional short-circuit current (1 kA)	6A gG
Mechanical life	>10 ⁷ operations

Transistor outputs	
External supply to Y13	Short-circuit proof +5 to +30 VDC
Y14	Indicates that the input conditions have been fulfilled
Y24	Indicates that the output relays are activated
Maximum load of Y14, Y24	15 mA /output
Maximum voltage drop at maximum load	2.4 V
LED indication	
On ●	Supply voltage OK, the LED is on. Flashing light in case of under-voltage or overload
In1 ● In2 ●	Indicates that the input conditions are fulfilled.
☑ ● 1 ☑ ● 2	Indicates that the output relays are activated.
Mounting	
Rail	35 mm DIN rail
Connection blocks (detachable)	
Maximum screw torque	1 Nm
Maximum connection area:	
Solid conductors	1x4 mm ² / 2x1.5 mm ² / 12AWG
Conductor with socket contact	1x2.5mm ² /2x1mm ²
Protection class	
Enclosure	IP40 IEC 60529
Connection blocks	IP20 IEC 60529
Operating temperature range	
	-10°C to + 55°C (with no icing or condensation)
Operating humidity range	
	35% to 85%
Impulse withstand Voltage	
	2.5kV
Pollution degree	
	2
Performance (max.)	
The relays must be cycled at least once a year.	PL e/Cat. 4 (EN ISO 13849-1:2008) SIL 3 (EN 62061:2005)PFH _d 1.35 E-08
Conformity	
	2006/42/EC, 2006/95/EC, 2004/108/EC, EN 62061:2005, EN ISO 13849-1:2008

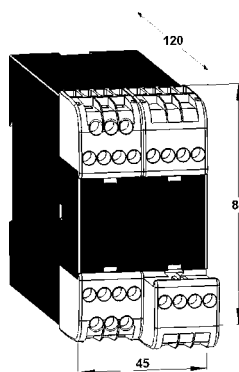

Connector blocks are detachable (without cables having to be disconnected)

Safety relay RT7



6

Universal relay with delayed outputs

The RT7 is a universal relay that can be used to supervise both safety devices and the internal safety of your machinery. In addition, you can select the safety level that is required for each installation. All this is possible because the RT7 has the most versatile input options arrangement available on the market. The RT7 can therefore replace many other relays.

The RT7 has four (4 NO) dual safety outputs of which two may be delayed for up to three seconds in order to achieve a safe and 'soft' stop. A 'soft' stop allows machinery to brake and stop gently before power is removed. A 'soft' stop has many benefits: the machinery life will be prolonged, processed products will not be damaged, and restarts from the stopped position are made possible and easier.

Another option with the RT7 is manual or automatic resetting. A manual supervised reset is used for gates and other safety devices that can be bypassed, while an automatic reset is used for small safety hatches if deemed appropriate from a risk point of view.

In addition, the RT7 has information outputs that follow the inputs and outputs of the relay. These outputs indicate if for example a gate is opened or closed, if there is a delay or if the relay needs to be reset.

Choose the RT7 to simplify your safety circuits and reduce your costs.

Approvals:



Safety relay for:

- Emergency stops
- Light curtains
- Three position devices
- Interlocked gates/hatches
- Magnetic switches
- Light beams
- Safety mats
- Contact strips
- Foot operated switches

Features:

- 4 NO / 1 NC relay outputs, 2 NO outputs can be delayed for soft stops
- Delay times RT7A 0; 0.5; 1.0; 1.5 s RT7B 0; 1.0; 2.0; 3.0 s
- Five input options
- Single or dual channel input
- Manual supervised or automatic reset
- Test input for supervision of external contactors
- Width 45 mm
- LED indication of supply, inputs, outputs, short-circuit and low voltage level
- Three voltage free transistor information outputs
- Supply 24 VDC, 115 or 230 VAC
- Quick release connector blocks

RT7 A/B

Technical information

Inputs

The RT7 can be configured to operate in either of the following input options:

1. Single channel, 1 NO contact from +24 VDC, safety category 1, up to PL c
2. Dual channel, 2 NO contacts from +24 VDC, category 3, up to PL d
3. Dual channel, 1 NO, 1 NC contact from +24 VDC, category 4, up to PL e
4. Dual channel, 1 NO contact from 0V and 1 NO contact from +24 VDC, category 4, up to PL e
5. Safety mats/contact strips, 1 'contact' from 0V and 1 'contact' from +24 VDC, category 3, up to PL d

When the input/inputs are activated and the test/supervised reset is complete, relays 1,2,3 and 4 are activated. Relays 1 and 2 are immediately de-energized when the inputs are deactivated in accordance with the input option selected. Relays 3 and 4 are either de-energized immediately or after the selected time delay. All the relays (1,2,3 and 4) must be de-energized before the RT7 can be reset.

Transistor output status information

The RT7 has three(3) voltage free transistor outputs that can be connected to a PLC, computer or other monitoring device. These outputs give the input and output status of the relay.

Reset and testing

The RT7 has two reset options; manual and automatic. The manual supervised reset is utilised when the RT7 is used to monitor safety devices that can be bypassed, i.e. to ensure that the outputs of the safety relay do not close just because the gate is closed.

The automatic reset should only be used if acceptable from a risk point of view. The RT7 can also test (supervise), if for example, contactors and valves etc are de-energized/de-activated before a restart is allowed.

Indication of low voltage

The 'On' LED will flash if the relay voltage falls below an acceptable level. This indication will also be given if a monitored safety mat contact strip is actuated. See connection option 5.

Safety level

The RT7 has internal dual and supervised safety functions. Power failure, an internal faulty component or external interference will not present a risk to options with the highest safety level. A manual reset requires that the reset input is closed and opened before the safety relay outputs are activated. A short-circuit or a faulty reset button is consequently supervised.

When the RT7 is configured for dual channel input, both the inputs are supervised for correct sequence operation before the unit can be reset. The input options 3 and 4 have the highest safety levels as all short-circuits and power failures are supervised. This in combination with internal current limitation makes the relay ideal for supervision of safety mats and contact strips.

Regulations and standards

The RT7 is designed and approved in accordance with appropriate directives and standards. See tekniska data.

Connection examples

For examples of how our safety relays can solve various safety problems, see the section "Connection examples".

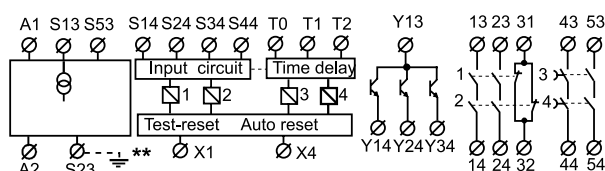

**Only for AC supply

Connection examples – RT7

DC supply

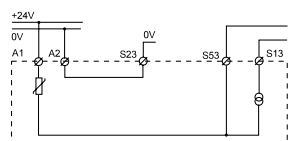

The RT7 DC option should be supplied with +24 V on A1 and 0 V on A2.

AC supply

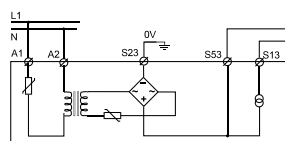

The RT7 AC option should be supplied with the appropriate supply voltage via connections A1 and A2.

The S23/ \perp must be connected to protective earth

DC-supply of AC-units

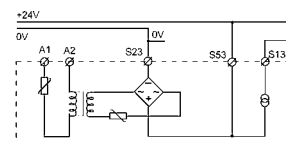

All AC-units can also be supplied by +24 VDC to S53 (0 VDC to S23).

Connection of safety devices - RT7 A/B

1. SINGLE CHANNEL, 1 NO from +24V

The input (contact to S14) must be closed before the outputs can be activated. When the input contact is opened the relay safety output contacts open.

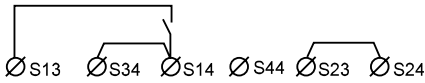

2. DUAL CHANNEL, 2 NO from +24V

Both input contacts (S14 and S34) must be closed before the relay outputs can be activated. The safety relay contacts will open if one or both of the input contacts are opened. Both the input contacts must be opened before the relay can be reset. A short-circuit between the inputs S14 and S34 can only be supervised if the device connected to the inputs has short-circuit supervised outputs, e.g. ABB Jokab Safety's Focus light curtains.

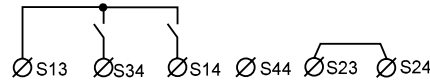

3. DUAL CHANNEL, 1 NO, 1 NC from +24V

One input contact must be closed (S14) and one opened (S44) before the relay outputs can be activated. The safety relay contacts will open if one or both of the inputs change state or in the case of a short-circuit between S14 and S44. Both inputs must be returned to their initial positions before the relay outputs can be reactivated.

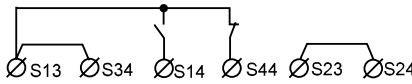

4. DUAL CHANNEL, 1 NO from +24V, 1 NO from 0V

Relay functions as option 2, but a short-circuit, in this case between inputs S14

and S24, is supervised (safety outputs are opened)

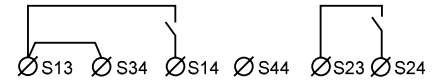

5. Safety mat/Contact strip

Both 'contact' inputs from an inactivated safety mat/contact strip, must be made in order to allow the RT7 relay outputs to be activated. When the safety mat/contact strip is activated or a short-circuit is detected across S14-S23, the relay will de-energize (safety outputs open) and the 'ON' LED will flash. As output S13 has an internal current limit of 70 mA, the RT7 will not be overloaded when the mat/contact strip is activated or a short circuit is detected.

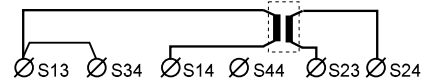

6

Reset connections - RT7 A/B

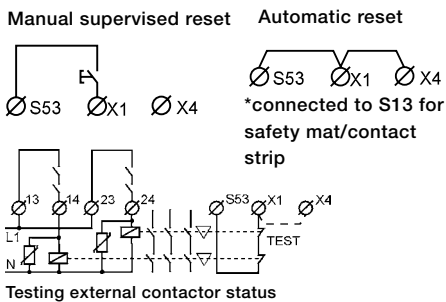

The manual supervised reset contact connected to input X1 must be closed and opened in order to activate the relay outputs.

Automatic reset is selected when S53, X1 and X4 are linked. The relay outputs are then activated at the same time as the inputs.

Contactors, relays and valves can be supervised by connecting 'test' contacts between S53 and X1. Both manual supervised and automatic reset can be used.

Output connections - RT7 A/B

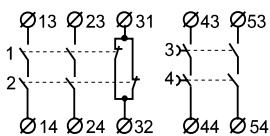

Relay outputs

The RT7 has four (4 NO) safety outputs of which two can be delayed, and 1 NC information output.

In order to protect the RT7 output contacts it is recommended that loads (inductive) are suppressed by fitting correctly chosen VDR's, diodes etc. Diodes are the best arc suppressors, but will increase the switch off time of the load.

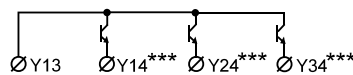

Transistor outputs

The RT7 has three(3) voltage free transistor information outputs.

The transistor outputs are supplied with voltage to Y13 either from S53 (+24V) or externally from 5 to 30 VDC. Y14, Y24 and Y34 follow the inputs and outputs as follows:

- Y14 becomes conductive when the relay input conditions are fulfilled.
- Y24 becomes conductive when both the output relays are activated.
- Y34 becomes conductive when both the delay output relays are activated.

RT7A	RT7B	T0	T1	T2	RT7A	RT7B	T0	T1	T2
0.0s	0.0s	Ø	Ø	Ø	1.0s	2.0s	Ø	Ø	Ø
0.5s	1.0s	Ø	Ø	Ø	1.5s	3.0s	Ø	Ø	Ø

Time delay outputs







Time delays are selected by linking the appropriate T0, T1 and T2 connections.

When a stop signal is detected a program stop command is first given to the PLC/servo which brakes the dangerous machine operations in a 'soft' and controlled way.

The delayed relay safety outputs will then turn off the power to the motors, i.e. when the machinery has already stopped. It takes usually around 0.5 to 3 seconds for a dangerous action to be stopped softly.

Technical data - RT7 A/B

Article number	
RT7B	24 VDC 3 s 24 VAC 3 s 115 VAC 3 s 230 VAC 3 s
RT7A	24 VDC 1.5 s 24 VAC 1.5 s 115 VAC 1.5 s 230 VAC 1.5 s
2TLA010028R1000	
2TLA010028R1200	
2TLA010028R1400	
2TLA010028R1500	
2TLA010028R2000	
2TLA010028R2200	
2TLA010028R2400	
2TLA010028R2500	
Colour	Black and beige
Weight	405 g (24 VDC) 550 g (24-230 VAC)
Supply	
Voltage (A1-A2)	24 VDC +15/-20%, 115/230 VAC, ±15%, 50-60 Hz
Power consumption	
DC supply, nominal voltage	4.6 W
AC supply, nominal voltage	8.8 VA
Connection S13 Short-circuit protected voltage output, 70 mA ±10% current limitation. Is used for the inputs S14, S34 and S44.	
Connection S53 Short-circuit protected voltage output, internal automatic fuse, max 270 mA. Is used for the reset and autoreset inputs X1 and X4.	
Connection S23 OV connection for input S24.	
Safety inputs	
S14 (+) input	20 mA
S24 (OV) input	20 mA
S34 (+) input	20 mA
S44 (+) input	25 mA
Reset input X1	
Supply for reset input	+ 24VDC
Reset current	600 mA current pulse at contact closure, then 30 mA.
Minimum contact closure time for reset	100 ms
Maximum external connection cable resistance at nominal voltage for	
S14, S24, S34	300 Ohm
S44, X1	150 Ohm
Response time	
At Power on DC/AC	<90/<140 ms
When activating (input-output)	<20 ms
When deactivating (input-output)	<20 ms
At Power Loss	<80 ms
Delay time options	
RT7A	0; 0.5; 1.0; 1.5 secs
RT7B	0; 1.0; 2.0; 3.0 secs
Relay outputs	
NO direct (relays 1/2)	2
NO direct or delayed (relays 3/4)	2
NC (relays 1/2)	1
Maximum switching capacity	
Relays 1/2 Resistive load AC	6A/250 VAC/1500 VA
Inductive load AC	AC15 240 VAC 2A
Resistive load DC	6A/24 VDC/150 W
Inductive load DC	DC13 24 VDC 1A
Relays 1/2 total	Max 9A distributed on all contacts
Relays 3/4 Resistive load AC	6A/230 VAC/1380 VA
Inductive load AC	AC15 230 VAC 4A
Resistive load DC	6A/24 VDC/144W
Inductive load DC	DC13 24 VDC 2A
Relays 3/4 total	Max 6A distributed on all contacts

Contact material	AgSnO ₂ + Au flash
Fuses output 1/2 (external)	5A gL/gG
Fuses output 3/4 (external)	3A gL/gG
Conditional short-circuit current (1 kA), each output	6A gG
Mechanical life	>10 ⁷ operations
Transistor outputs	
External supply to Y13	+5 to +30 VDC
Y14	Indicates that the input conditions are fulfilled
Y24	Indicates that the output relays 1/2 are activated
Y34	Indicates that the delay output relays 3/4 are activated
Maximum load of Y14,Y24, Y34	15 mA /output
Maximum voltage drop at maximum load	2.4 V
LED indication	
On 	Supply voltage OK, the LED is on.
In1  In2 	Flashing light in case of under-voltage or overload.
 1  2	Indicates that the input conditions are fulfilled.
t 	Indicates that the output relays 1/2 are activated.
	Indicates that the delay output relays 3/4 are activated.
Mounting	
Rail	35 mm DIN rail
Connection blocks (detachable)	
Maximum screw torque	1 Nm
Maximum connection area:	
Solid conductors	1x4 mm ² / 2x1,5 mm ² /12AWG
Conductor with socket contact	1x2.5 mm ² / 2x1 mm ²
Protection class	
Enclosure	IP40 IEC 60529
Connection blocks	IP20 IEC 60529
Operating temperature range	
24 VDC	-10° C to + 55° C (with no icing or condensation)
24-230 VAC	-10° C to + 45° C (with no icing or condensation)
Operating humidity range	
	35% to 85%
Impulse withstand Voltage	
	2.5kV
Pollution degree	
	2
Performance (max.)	
The relays must be cycled at least once a year.	PL e/Cat. 4 (EN ISO 13849-1:2008) SIL 3 (EN 62061:2005) PFH _d 1,86 E-08
Conformity	
	2006/42/EC, 2006/95/EC, 2004/108/EC EN 62061:2005 EN ISO 13849-1:2008

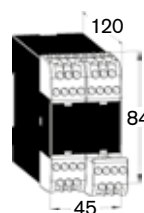

Connector blocks are detachable (without cables having to be disconnected)

Safety relay RT9



Approvals:



Safety relay for:

- Emergency stops
- Light curtains
- Three position devices
- Interlocked gates/hatches
- Magnetic switches
- Light beams
- Safety mats
- Contact strips
- Foot operated switches

Features:

- Five input options
- Single or dual channel input
- Manual supervised or automatic reset
- Test input for supervision of external contactors
- Width 22.5 mm
- LED indication of supply, inputs and outputs, short-circuit and low voltage level
- 2 NO relay outputs
- One changeover relay with a double information output
- Supply 24 VDC
- Quick release connector blocks

Would you like a small safety relay for all your safety applications?

Then choose the compact RT9 universal relay to supervise both your safety devices and the internal safety of your machinery. In addition, you can select the safety level that is required for each installation. All this is possible due to the RT9 offering the most versatile input option arrangement available on the market. The RT9 can therefore replace many other relays.

Other RT9 options include selection of either manual supervised or automatic resetting. The manual supervised reset can be used for gates and other safety devices that can be bypassed. Automatic reset can be used for small safety hatches, if deemed acceptable from risk assessment.

In addition, the RT9 has a double information output that will indicate e.g if a gate is open or if the relay needs resetting.

The RT9 uses the latest component technology and modern assembly techniques to ensure a highly cost effective solution.

Choose the RT9 to simplify your safety circuits and reduce your costs.

RT9

Technical information

Inputs

The RT9 can be configured to operate in either of the following input options:

1. Single channel, 1 NO contact from +24 VDC, category 1, up to PL c
2. Dual channel, 2 NO contacts from +24 VDC, category 3, up to PL d
3. Dual channel, 1 NO, 1 NC contact from +24 VDC, category 4, up to PL e
4. Dual channel, 1 NO contact from 0V and 1 NO contact from +24 VDC, category 4, up to PL e
5. Safety mat/contact strips, 1 'contact' from 0V and 1 'contact' +24 VDC, category 3, up to PL d

When the input/inputs are activated and the test/supervised reset is complete, relays 1 and 2 are energised. These are de-energised when the input/inputs are de-activated in accordance with the input option chosen or in case of a power failure.

Relays 1 and 2 must both be de-energized before the RT9 can be reset.

Relay output status information

The RT9 has a changeover contact relay output that can be connected to a PLC, control lamp, computer or similar. The output gives information about the status of the relay.

Reset and testing

The RT9 has two reset options; manual and automatic. The manual supervised reset can be used when the RT9 is monitoring safety devices that can be bypassed, i.e. to ensure that the outputs of the safety relay do not close just because a gate is closed. The automatic reset option should only be used if appropriate from a risk point of view.

Due to special internal circuits the RT9 can be automatically reset regardless of the operational voltage rise time, this being an important factor when large loads are started up on the same power supplies at the same time.

In addition, the RT9 can also test (supervise), if for example, contactors and valves etc are de-energised/de-activated before a restart is made.

Indication of low voltage

The 'On' LED will flash if the relay supply voltage falls below an acceptable level. This indication will also be given if a monitored safety mat/contact strip is actuated. Please see Connection option 5.

Safety level

The RT9 has internal dual and supervised safety functions. Power failure, an internal faulty component or external interference will not present a risk to options with the highest safety level. A manual reset requires that the reset input is closed and opened before the safety relay outputs are activated. A short-circuit or a faulty reset button is consequently supervised.

When the RT9 is configured for dual channel input, both the inputs are supervised for correct operation before the unit can be reset.

The input options 3 and 4 have the highest safety levels as all short-circuits and power failures are supervised. This in combination with an internal current limitation makes the relay ideal for supervision of safety mats and contact strips.

Regulations and standards

The RT9 is designed and approved in accordance with appropriate directives and standards. See technical data.

Connection examples

For examples of how our safety relays can solve various safety problems, please see the section "Connection examples".

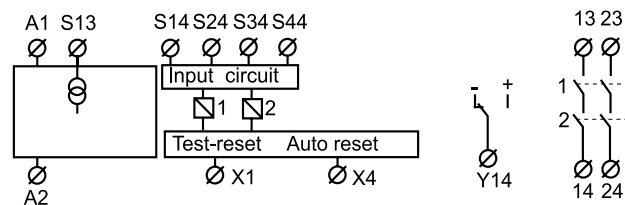

Connection of supply - RT9

DC supply

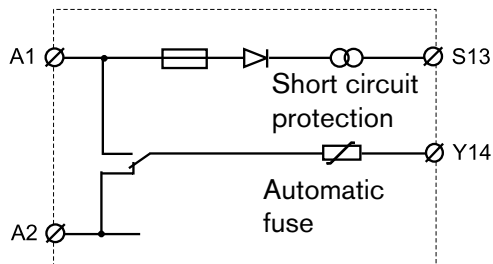

The RT9 should be supplied with +24 V on A1 and 0 V on A2.

NOTE! If cable shielding is used this must be connected to an earth rail or an equivalent earth point.

Connection of safety devices - RT9

1. SINGLE CHANNEL, 1 NO from +24V

The input (contact to S14) must be closed before the outputs can be activated. When the input contact is opened, the relay safety output contacts open.

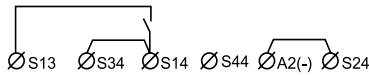

2. DUAL CHANNEL, 2 NO from +24V

Both input contacts (S14 and S34) must be closed before the relay outputs can be activated. The safety relay contacts will open if one or both of the input contacts are opened. Both the input contacts must be opened and reclosed before the relay can be reset.

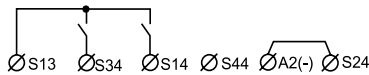

A short-circuit between inputs S14 and S34 can only be supervised if the device connected to the inputs has short-cir-

cuit supervised outputs, e.g. ABB Jokab Safety's Focus light curtains

3. DUAL CHANNEL, 1 NO, 1 NC from +24V

One input contact must be closed (S14) and one opened (S44) before the relay outputs can be activated.

The safety relay contacts will open if one or both of the inputs change state or in case of a short-circuit between S14 and S44. Both inputs must be returned to their initial status before the relay outputs can be reactivated.

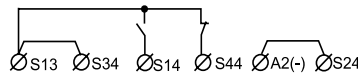

4. DUAL CHANNEL, 1 NO from +24V, 1 NO from 0V

Relay functions as option 2, but a short-circuit, in this case between inputs S14

and S24, is supervised (safety outputs are opened).

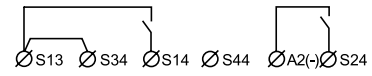

5. Safety mat/Contact strip

Both 'contact' inputs from an inactivated safety mat/contact strip must be made in order to allow the RT9 relay outputs to be activated. When the safety mat/contact strip is activated or a short-circuit is detected across S14-S23, the relay will de-energize (safety contacts open) and the 'ON' LED will flash. As output S13 has an internal current limit of 70 mA, the RT9 will not be overloaded when the mat/contact strip is activated or a short-circuit is detected.

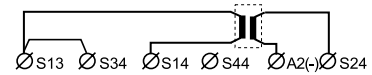

6

Reset connections - RT9

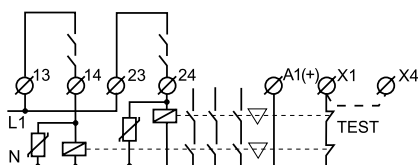
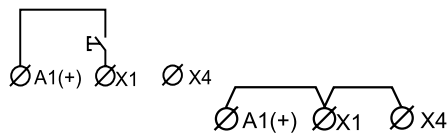

Manual supervised reset

The manual supervised reset contact connected to input X1 must be closed and opened in order to activate the relay outputs.

Automatic reset

Automatic reset is selected when A1(+), X1 and X4 are linked. The relay outputs are then activated at the same time as the inputs.

Testing external contactor status

Contactors, relays and valves can be supervised by connecting 'test' contacts between A1(+) and X1. Both manual supervised and automatic reset can be used.

Output connections - RT9

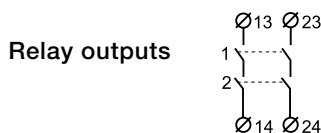

The RT9 has two (2 NO) safety outputs.

In order to protect the output contacts it is recommended that loads (inductive) are suppressed by fitting correctly chosen VDR's, diodes etc. Diodes are the best arc suppressors, but will increase the switch off time of the load.

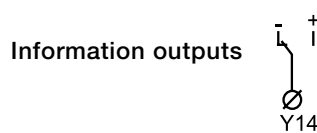

The RT9 has a single changeover contact information relay output. The relay output Y14 is connected internally to 0V and 24V in the following way:

- Y14 is internally closed to 0V when the RT9 is not reset.
- Y14 is internally closed to +24V when the relay is reset.

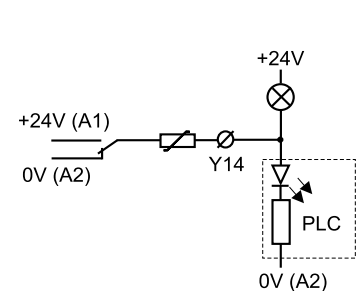

Technical data – RT9

Article number RT9 24 VDC	2TLA010029R0000
Colour	Grey
Weight	210 g
Supply Voltage (A1-A2)	24 VDC ±20%
Power consumption Nominal voltage	2 W
Connection S13	Short-circuit protected voltage output 70 mA ± 10% current limitation. Is used for the inputs S14, S34 and S44.
Input currents (at nominal supply voltage)	
S14 (+) input	30 mA
S24 (0V) input	20 mA
S34 (+) input	20 mA
S44 (+) input	25 mA
Reset input X1 Supply for reset input Reset current	+ 24 VDC 300 mA current pulse at contact closure, then 30 mA
Minimum contact closure time for reset	80 ms
Minimum contact closure time (at low limit voltage -20%)	100 ms
Maximum external connection cable resistance at a nominal voltage for	
S14, S24, S34	300 Ohm
S44, X1	150 Ohm
Response time At Power on When activating (input-output) When deactivating (input-output) At Power Loss	<100 ms <20 ms <20 ms <80 ms
Relay outputs NO Maximum switching capacity	2
Resistive load AC Inductive load AC Resistive load DC Inductive load DC Max. total switching capacity: Minimum load	6A/250 VAC/1500 VA AC15 240 VAC 2A 6A/24 VDC/150 W DC13 24 VDC 1A 8A distributed on all contacts 10 mA/10V (if load on contact has not exceeded 100 mA)
Contact material	Ag+Au flash
Fuses output (External)	5A gL/gG
Conditional short-circuit current (1 kA)	6A gG
Mechanical life	10 ⁷ operations
Relay information output Y14 (Changeover contacts) -(0V) +(24V) Maximum load of Y14 Short-circuit protection for information output	Indicates that RT9 is not reset. Indicates that RT9 is reset. 250 mA Internal automatic fuse

LED indication On ● In1 ● In2 ● ☑ ● 1 ☑ ● 2	Supply voltage OK, the LED is on. Flashing light in case of under-voltage, overload or current limiting Indicates that the input conditions are fulfilled. Indicates that the output relays have been activated.
Mounting Rail	35 mm DIN rail
Connection blocks (detachable) Maximum screw torque Maximum connection area: Solid conductors Conductor with socket contact	1 Nm 1x4 mm ² / 2x1.5 mm ² / 12AWG 1x2.5 mm ² / 2x1 mm ²
Protection class Enclosure Connection blocks	IP40 IEC 60529 IP20 IEC 60529
Operating temperature range	-10°C to + 55°C (with no icing or condensation)
Operating humidity range	35% to 85%
Impulse withstand Voltage	2.5kV
Pollution degree	2
Performance (max.) The relays must be cycled at least once a year.	PL e/Cat. 4 (EN ISO 13849-1:2008) SIL 3 (EN 62061:2005)PFH _d 9.55E-09
Conformity	2006/42/EC, 2006/95/EC, 2004/108/EC EN 62061:2005 EN ISO 13849-1:2008

6

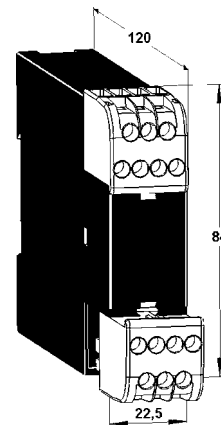

Connector blocks are detachable
(without cables having to be disconnected)

Safety relay JSBRT11

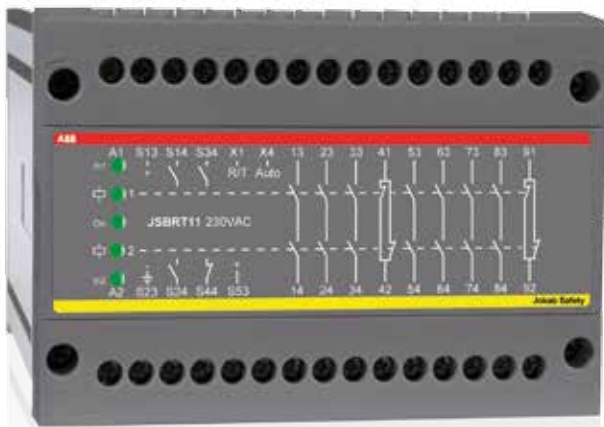

6

A flexible safety relay with many outputs

The JSBRT11 has been designed to provide the safety system circuit designer with the ability to select from both a range of input connection configurations and either automatic or supervised reset.

The unit can be hardwire configured to operate in either of the following input configurations:

- Mode 1: Single Channel (1 NO contact from +24 VDC), category 1 PL c
- Mode 2: Dual Channel (2 NO contacts from +24 VDC), category 3 PL d
- Mode 3: Dual Channel (1 NO, 1NC contacts from +24 VDC), category 4 PL e.
- Mode 4: Dual Channel (1 NO contact from 0 V and 1 NO contact from + 24 VDC), safety category 4.

In addition the unit can also be used to test that contactors and valves have fallen/returned to their 'reset' state before a new 'start' signal is given.

Safety level

The JSBRT11 has dual and monitored internal safety functions. Power failure, internal component failures or external interference (with the exception of short circuiting of input contact when used in a single channel input mode) do not result in a dangerous function.

Approvals:



Safety relay for:

- Emergency stops
- Light curtains
- Three position devices
- Interlocked gates/hatches
- Magnetic switches
- Light beams
- Safety mats
- Foot operated switches

Features:

- Selectable inputs and safety category
- Manual supervised or automatic reset
- Width 100 mm
- LED indication for supply, inputs and outputs
- 7 NO + 2 NC relay outputs
- Supply 24 VDC 15 or 230 VAC
- Quick release connector blocks

When wired for supervised reset, should a short circuit appear across the reset input the relay will not automatically reset when the input/inputs are made. Only when the super-vised reset input is made and broken will the relay reset.

The JSBRT11 provides detection of contact failure in the inputs when wired in dual channel mode. Both inputs have to be opened and closed in order to enable the reactivation of the relay. The highest safety level of the JSBRT11 is in configuration mode 3 and 4 because all short circuits are supervised i.e. a short circuit between the inputs leads to a safe state as the outputs drop out.

Regulations and standards

The JSBRT11 is designed and approved in accordance with appropriate directives and standards. See technical data.

Connection examples

For examples of how our safety relays can solve various safety problems, please see the section "Connection examples".

Technical description – JSBRT11

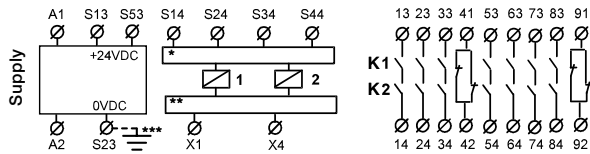

*Supervision circuit **Test and Automatic reset circuit
 *** Only for AC-supply

The supply voltage is connected across A1 and A2. The input connection configuration and type of reset required is set by connecting the unit as shown in the diagrams below

When the input/inputs and the test/supervised reset are made K1 and K2 energise. K1 and K2 will de-energise if the power is disconnected or a stop signal is given in accordance to the configuration mode wired. Both K1 and K2 have to be de-activated before the outputs of the JSBRT11 can be closed again.

– Configuration mode 1.

When the single input opens both K1 and K2 relays are deactivated.

– Configuration mode 2.

Both inputs have to be closed in order to enable the unit to be activated. A stop signal is given if both or one input is opened. Both inputs have to be opened and reclosed in order to enable the reactivation of the unit. If the possibility of short circuits between the inputs cannot be excluded, configuration mode 3 or 4 should be used in order to reach the highest safety level.

– Configuration mode 3.

One input has to be closed and the other input has to be opened in order to enable the unit to be activated. A stop signal is given if both or one input change state. Both inputs have to change state in order to give a dual stop function and to allow a new start after stop.

– Configuration mode 4.

Operation as mode 2 but short circuits between the inputs leads to a safe state i.e. the relays inside the JSBRT11 will drop out.

– Supervised reset connection.

The input to X1 (see diagram below) has to be closed and opened in order to activate the unit, after input/inputs are made according to the configuration mode selected. This mode is selected when X1 - X4 is open-circuit.

– Automatic reset connection.

The input has to be closed in order to activate the unit after input/inputs are made according to the configuration mode selected. This mode is selected when a connection between X1 and X4 is made.

– Test.

Test contacts of contactors can be connected between S53 and X1 for supervision.

Technical data – JSBRT11

Article number	2TLA010025R0000
JSBRT11 24 VDC	2TLA010025R0400
JSBRT11 115 VAC	2TLA010025R0500
JSBRT11 230 VAC	
Colour	Grey
Power supply A1 - A2	24 VDC ± 15%
	115, 230 VAC ± 15%, 50-60 Hz
Power consumption	3.2 W/7.9 VA
Relay Outputs	7 NO and 2 NC
Max. switching capacity	
Resistive load AC	6A/250 VAC/1500 VA
Inductive load AC	AC15 240 VAC 2A
Resistive load DC	6A/24 VDC/150 W
Inductive load DC	DC13 24 VDC 1A
Max. total switching capacity	21A distributed on all contacts
Min. load	10mA/10 V (if load on contact has not exceeded 100 mA)
Contact material	AgSnO ₂ + Au flash
Fuses Output (External)	6A gL/gG
Conditional short-circuit current (1 kA)	6A gG
Max. Input wire res. at nom. voltage	200 Ohm (S14,S24,S34,X1,X4); 100 Ohm (S44)
Response time at deactivation (input-output)	<20 ms
Response time at activation (input-output)	<30 ms
Terminals (max. screw torque 1 Nm)	
Single strand:	1x4 mm ² / 2x1.5 mm ²
Conductor with socket contact:	1x2.5 mm ² / 2x1 mm ²
Mounting	35 mm DIN-rail
Protection class enclosure	IP40 IEC 60259
Protection class terminals	IP20 IEC 60259
Impulse withstand voltage	2.5kV
Pollution degree	2
Operating temperature range	-10°C to +55°C (with no icing or condensation)
Operating humidity range	35% to 85%
Function indication	Electrical Supply, Input 1 and 2, Output relays 1 and 2
Weight	610 g (24 VDC) 790 g (24-230 VAC)
Performance (max.)	PL e/Cat. 4
Functional test: The relays must be cycled at least once a year.	(EN ISO 13849-1:2008) SIL 3 (EN 62061:2005) PFH _d 1.69E-08
Conformity	2006/42/EC, 2006/95/EC, 2004/108/EC, EN 62061:2005 EN ISO 13849-1:2008

Electrical connection – JSBRT11

SINGLE CHANNEL *, 1 NO from +24V DUAL CHANNEL*, 1 NO, 1 NC from +24V

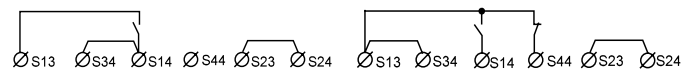

Safety relay JSBR4



6

A universal relay for two-hand and many other safety devices

The JSBR4 has two inputs, which both have to be closed to keep the safety output contacts closed. A short-circuit across the inputs will cause the output contacts to open. The inputs can however be subjected to a continuous short-circuit without damaging the safety relay.

In order to make the safety outputs close the reset input must be closed and opened. In this way an unintentional reset is prevented in the case of a short-circuit in the reset button cable or if the button gets jammed in the actuated position. The reset input can also be used for test/supervision to ensure that contactors or valves have returned to their initial off/stop position before a new start can be allowed by the safety relay.

When the JSBR4 is used as a two-hand device relay, both buttons have to be pressed within 0.5 seconds of each other in order to close the outputs.

When the JSBR4 is used for Safety Mats and Safety Strips the "stop" condition is given following detection of a short-circuit between input channels A and B. The safety mat, safety strip or the relay will not be damaged by a continuous short-circuit. This also gives the advantage that if there is a failure between the inputs in the installation, the safety relay will not be damaged.

Approvals:



Safety relay for:

- Two-hand devices of type IIIc
- Emergency stop
- Three position devices
- Interlocked Gates/Hatches
- Contact strips
- Safety mats
- Foot operated switches

Features:

- Two channel with concurrency requirement of 0.5 s
- Supervised reset
- Test input
- Width 45 mm
- LED indication for supply, inputs and outputs
- 3 NO/1NC relay outputs
- Supply 24 VDC, 24, 115 or 230 VAC
- Quick release connector blocks

Safety level

The JSBR4 has a twin supervised safety function. Component failure, short-circuit or external disturbance (e.g. loss of power supply) will not prevent the safe function of the relay. This is valid both for the inputs A and B as well as for the reset input. The JSBR4 operates at the highest safety level for safety relays (PL e according to EN ISO 13849-1).

Regulations and standards

The JSBR4 is designed and approved in accordance with appropriate directives and standards. See technical data. The JSBR4 complies with the highest safety level for the connection of a two-hand device of type IIIc in accordance with EN 574.

Connection examples

For examples of how our safety relays can solve various safety problems, please see the section "Connection examples".

Technical description – JSBR4

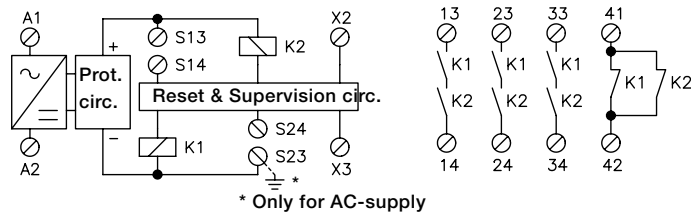

The electrical supply is connected across A1 and A2. After Voltage reduction and Rectification (AC-versions) or reverse polarity protection (DC-version) there is an overload protection-circuit.

When the inputs S13-S14 and S23-S24 have closed and the reset is made, the relays K1 and K2 are activated. A dual stop signal is given when K1 and K2 drop, due to short circuiting between the inputs, opening of the inputs or power failure. If one input is opened the other input must also be opened for K1 and K2 to be activated again.

The monitoring circuit checks K1 and K2 and that the reset circuit to X2 is both closed and opened before K1 and K2 are energized. Both the stop and reset function therefore comply with the requirement that a component fault, short circuit or external interference do not result in a dangerous function.

The safety outputs consist of contacts from K1 and K2 connected internally in series across terminals 13 - 14, 23 -24 and 33 - 34. These contacts are used to cut the power to components which stop or prevent hazardous movements/ functions. It is recommended that all switched loads are adequately suppressed and/or fused in order to provide additional protection for the safety contacts.

NOTE! Output 41-42 is intended for indication purposes only, e.g. gate opened.
No load between S14 and S24 allowed.

Electrical connection – JSBR4

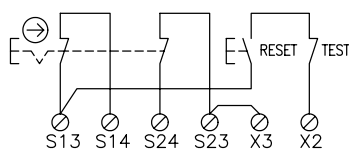

Emergency stop with manual resetting.

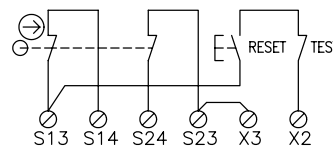

Interlocked gate with manual reset.

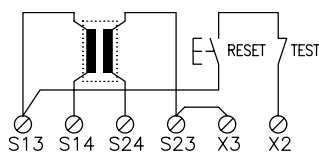

Contact mat/strip with manual reset.

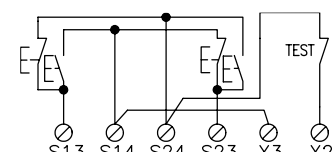

Two hand device with buttons in separate or same enclosure. Buttons to be pressed in within 0.5 s of each other. Footpedal switches can be connected in the same configuration.

Technical data – JSBR4

Article number	2TLA010002R0000 JSBR4 24 VDC 2TLA010002R0200 JSBR4 24 VAC 2TLA010002R0400 JSBR4 115 VAC 2TLA010002R0500 JSBR4 230 VAC
Colour	Black and beige
Power supply	24 VDC ± 15% 24/115/230 VAC ± 15%, 50 - 60 Hz
Power consumption	1.3 W/3.3 VA
Relay outputs	3 NO + 1 NC
Max. switching capacity	Resistive load AC 6A/250 VAC/1500 VA Inductive load AC AC15 240 VAC 2A Resistive load DC 6A/24 VDC/150 W Inductive load DC DC13 24 VDC 1A
Max. res. load total switching capacity	12A distributed on all contacts
Min. load	10mA/10 V (if load on contact has not exceeded 100 mA)
Contact material	Ag + Au flash
Fuses output (external)	5A gL/gG
Conditional short-circuit current (1 kA)	6A gG
Max. Input wire res. at nom. voltage	300 Ohm (S13 - S14 and S23 - S24)
Response time at deactivation	< 20 ms (145 ms at power loss)
Terminals (max. screw torque 1 Nm)	Single strand: 1 x 2.5 mm ² / 2 x 1 mm ² . Conductor with socket contact: 1 x 4 mm ² / 2 x 1.5 mm ² .
Mounting	35 mm DIN-rail
Protection class	IP40 / IP20 IEC 60529
Operating temperature range	-10°C to +55°C (with no icing or condensation)
Impulse withstand voltage	2.5kV
Pollution degree	2
Operating humidity range	35% to 85%
LED indication	Electrical Supply, Inputs, Outputs
Weight	350 g (24 VDC), 460 g (24-230 VAC)
Values	Safety Category 4 according to EN 954-1, PL e, SIL 3, PFH _d 1.35E-08
Conformity	2006/42/EC, 2006/95/EC, 2004/108/EC, EN 62061:2005 EN ISO 13849-1:2008

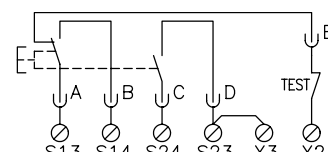

Enabling device, JSHD4. Stop condition is given in both top and bottom PB positions.

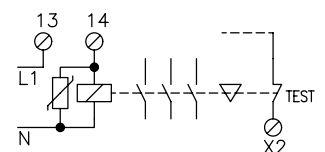

Control and supervision of external conductor, relay, valve or ABB Jokab Safety's expansion relays.

Safety relay JSBT4



6

Safety relay with synchronised dual input channels (within 0.5s)

The JSBT4 has two inputs, both of which have to be closed in order to keep the safety output contacts closed. A short circuit between inputs A and B will cause the output contacts to open. The inputs can be continuously short circuited without damaging the safety relay.

For the outputs to close, the test input must be closed. The test input is intended to monitor that contactors or valves have dropped/returned before a new start is permitted.

This test input must not be confused with the reset function required for gates that a person can walk through and where there is a high safety requirement (see JSBR4).

If the JSBT4 is used for safety Mats and safety Strips, the "stop" condition is given following detection of a short circuit. The safety mat, safety strip or the relay will not be damaged by a continuous short-circuit. This also provides the advantage that if there is a failure between inputs A and B in the installation, the safety relay will not be damaged.

Safety level

The JSBT4 has a twin supervised safety function. Component failure, short-circuit or external disturbance (e.g. loss of power supply) will not prevent the safe function of the relay. Safety category level 3 or 4, depending on use.

The true two-channel safety function has the advantage that the cabling installation demands for safety can be reduced,

Approvals:



Safety relay for:

- Emergency stops
- Three position devices
- Interlocked Hatches
- Safety mats
- Contact strips
- Foot operated switches

Features:

- Dual input channels synchronism 0.5 s
- Test input
- Width 45 mm
- LED indications for power on, inputs and outputs
- 3 NO/1NC relay outputs
- Supply 24 VDC
- Quick release connector blocks

due to the fact that a short-circuit between the inputs will directly open the relay's safety outputs.

Regulations and standards

The JSBT4 is designed and approved in accordance with appropriate directives and standards. See technical data.

Connection examples

For examples of how our safety relays can solve various safety problems, please see the section "Connection examples".

Technical description – JSBT4

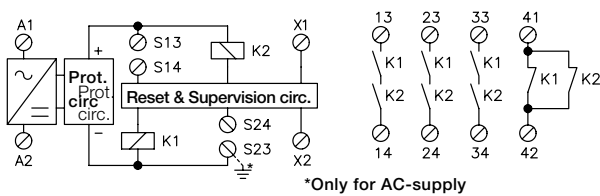

The electrical supply is connected across A1 and A2. After Voltage reduction and Rectification (AC-versions) or reverse polarity protection (DC-version) there is an overload protection-circuit.

When the inputs S13-S14 and S23-S24 are closed within 0.5 seconds of each other the relays K1 and K2 are energized. A dual stop signal is given, K1 and K2 de-energize, when there is a short circuit between or an opening of the inputs or at power loss. If one input is opened the other one also has to be opened in order to activate K1 and K2 again. The test circuit, X1 - X2, has to be closed in order to activate the outputs, thereafter the test circuit can be opened or closed continuously. If the test circuit is closed after the inputs there is no requirement to close them within 0.5 seconds of each other.

The internal supervision circuit monitors the two Inputs and relays K1, K2. The stop function then fulfils the requirement that one failure (short circuit, component, external disturbance) shall not prevent the safe function of the JSBT4.

The safety outputs consist of contacts from K1 and K2 connected internally in series across terminals 13 - 14, 23 - 24 and 33 - 34. These contacts are used to cut the power to components which stop or prevent hazardous movements/functions. It is recommended that all switched loads are adequately suppressed and/or fused in order to provide additional protection for the safety contacts.

The NC output 41 - 42 should only be used for monitoring purposes e.g. Indication lamp or PLC input etc. The output contacts are closed until the module is reset.

NOTE! Output 41-42 is intended for indication purposes only, e.g. gate opened. No load between S14 and S24 allowed.

Technical data – JSBT4

Article number	JSBT4 24 VDC JSBT4 24 VAC JSBT4 230 VAC	2TLA010004R0000 2TLJ010004R0200 2TLJ010004R0500
Colour		Grey
Power supply		24 VDC ±15%
Power consumption		BT50 1.4W/BT50T 1.8W
Relay outputs		3 NO + 1 NC
Max. switching capacity		
Resistive load AC		6A/250 VAC/1500 VA
Inductive load AC		AC15 240VAC 2A
Resistive load DC		6A/24 VDC/150 W
Inductive load DC		DC13 24VDC 1A
Max. res. load total switching capacity		12A distributed on all contacts
Min. load		10mA/10 V (if load on contact has not exceeded 100 mA)
Contact material		Ag + Au flash
Fuses output (external)		5A gL/gG
Conditional short-circuit current (1 kA)		6A gG
Max. Input wire res. at nom. voltage		300 Ohm (S13 - S14 and S23 - S24)
Response time at deactivation		< 20 ms, 145 ms with switched supply/power loss
Terminals (max. screw torque 1 Nm)		
Single strand		1x4 mm ² / 2x1.5 mm ²
Conductor with socket contact		1x2.5 mm ² / 2x1 mm ²
Mounting		35 mm DIN-rail
Protection class		IP40 / IP20 IEC 60529
Operating temperature range		-10°C to +55°C (with no icing or condensation)
Impulse withstand voltage		2.5kV
Pollution degree		2
Operating humidity range		35% to 85%
LED indication		Electrical Supply, Inputs, Outputs
Weight		350 g (24 VDC), 460 g (24-230 VAC)
Values		Safety Category 4 according to, PL _e SIL 3, PFH _p 1.51E-08
(With Proof test interval 1 year)		
Conformity		2006/42/EC, 2006/95/EC, 2004/108/EC, EN 62061:2005, EN ISO 13849-1:2008

Electrical connection – JSBT4

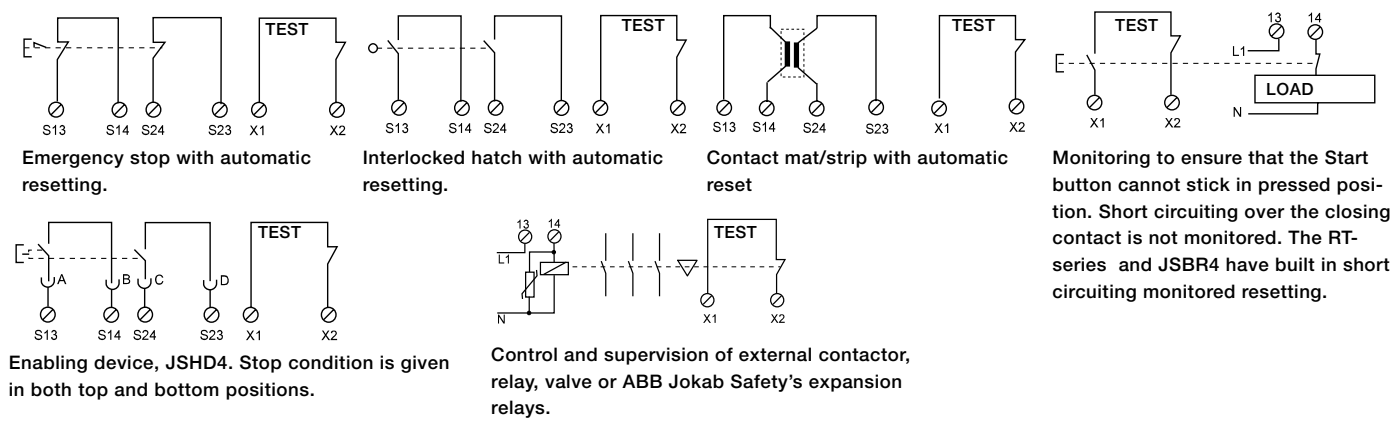

Safety relay/expansion relay BT50(T)



6

Safety relay/expansion relay to Pluto

The BT50 is designed to connect safety devices, such as emergency stops, directly in the voltage supply circuit to the relay. Despite a maximum built-in width of 22.5 mm the relay is very powerful.

With 3NO safety outputs, 1NC output (for monitoring purposes), a test input and complete internal supervision, the BT50 is quite unique. In addition, delayed outputs (BT50T) can be ordered.

In order for the safety outputs to close, the supply voltage, e.g. by means of an emergency stop button, must be connected to A1 and A2 and the test input closed. After actuation of the relay the test input can be opened again.

The test input is intended to supervise that contactors or valves have dropped/returned before a new start can be permitted. The test input can also be used for starting and the start button can be supervised (see the connection example on the next page).

More outputs

By connecting a BT50 to a safety relay/PLC it is easy to increase the number of safe outputs. This means that an unlimited number of dangerous machine operations and functions can be stopped by using just one safety-PLC.

Approvals:



Safety relay for:

- Emergency stop
- Interlocked hatch
- Expansion of Pluto

Features:

- Single and “dual” channel
- Test/“reset” input
- Width 22.5 mm
- LED indication
- 3 NO/1NC relay outputs
- Supply 24 VDC
- Quick release connector blocks
- BT50 - Additional power terminals
- BT50T - One changeover relay with a double information output (Y14)
- BT50T - Delay times selectable from 0 - 1.5 s

Safety level

BT50 have an internal redundant and monitored safety function. Power failure, internal component faults or external interference cannot result in dangerous functions.

Input via A1 on its own is not protected from short circuiting, and therefore installation is critical for the safety level to be achieved. To achieve a higher safety level a screened cable can be used and/or connection made to both A1 and A2 (see the example on the next page).

Regulations and standards

The BT50 is designed and approved in accordance with appropriate directives and standards. See technical data.

Connection examples

For examples of how our safety relays can solve various safety problems, please see the chapter “Connection examples”.

Technical description – BT50(T)

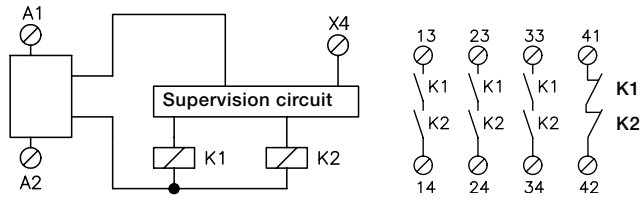

When supply voltage is connected to A1 and A2, relays K1 and K2 are activated. K1 and K2 drop if the supply voltage is disconnected. Both relays K1 and K2 must drop for them to be activated again. Another requirement is that the test circuit, A1 - X4, must be closed for the outputs to be activated. Thereafter A1 - X4 can either be open or constantly closed.

The supervising circuit ensures that both K1 and K2 have dropped before they can be reactivated. The stop function complies with the requirement that a component fault or external interference cannot lead to a dangerous function.

The safety outputs consist of contacts from K1 and K2 connected internally in series across terminals 13 - 14, 23 - 24, and 33 - 34. These contacts are used to cut the power to components which stop or prevent hazardous movements/functions. It is recommended that all switched loads are adequately suppressed and/or fused in order to provide additional protection for the safety contacts.

The NC output 41 - 42 should only be used for monitoring purposes e.g. indication lamp for emergency stop pressed.

BT50T - Info. output BT50T - Delay times

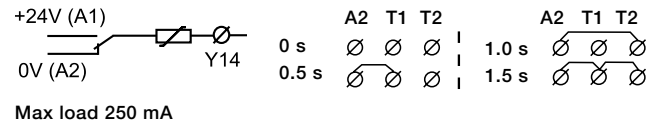

Max load 250 mA

Technical data – BT50(T)

Article number	BT50 BT50T	2TLA010033R0000 2TLA010033R1000
Colour		Black and beige
Operational voltage		24 VDC + 15%/-25%
Power consumption		BT51 1.4W/BT51T
Relay outputs		3 NO + 1 NC
Max. switching capacity		
Resistive load AC		6A/250 VAC/1500 VA
Inductive load AC		AC15 240 VAC 2A
Resistive load DC		6A/24 VDC/150 W
Inductive load DC		DC13 24 VDC 1A
Max. res. load total switching capacity		12A distributed on all contacts
Min. load		10mA/10 V(if load on contact has not exceeded 100 mA)
Contact material		Ag + Au flash
Fuses output (external)		5A gL/gG
Conditional short-circuit current (1 kA)		6A gG
Max Input wire res. at nom. voltage		200 Ohms
Response time at deactivation (input - output)		Version B <20 ms or delayed max 1500 ms (old version of BT50 <60 ms)
Terminals (max. screw torque 1 Nm)		
Single strand		2x1.5 mm ²
Conductor with socket contact		2x1 mm ²
Mounting		35 mm DIN-rail
Protection class enclosure/terminals		IP40 / IP20 IEC 60529
Impulse withstand voltage		2.5kV
Pollution degree		2
Operating temperature range		-10°C to +55°C (with no icing or condensation)
Operating humidity range		35% to 85%
LED indication		Electrical Supply, Relay and X4
Weight		200 g
Performance (max.)		PL e/Cat. 4 (EN ISO 13849-1:2008)
Functional test: The relays must be cycled at least once a year.		SIL 3 (EN 62061:2005) PFH ₀ 1.22E-08

Electrical connection – BT50(T)

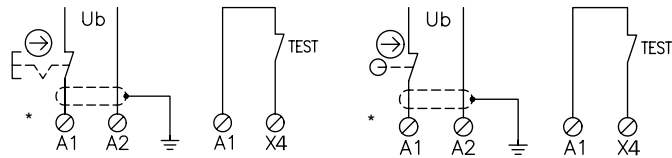

Emergency stop with reset when emergency button returns.

Hatch with automatic reset.

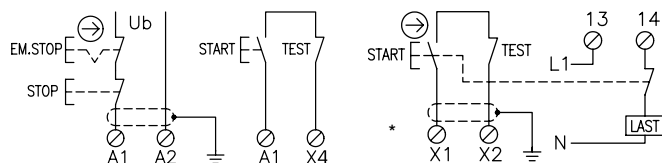

BT50 as emergency stop and control relay with Start and Stop function.

Emergency stop with dual connection direct to the supply voltage.

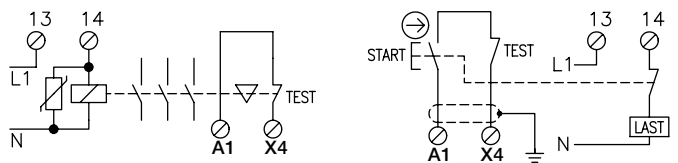

Controlled monitoring of external jockab safety's expansion relays.

Monitoring to ensure that the On button is not stuck in pressed position. A short circuit over the closing contact is not monitored.

* BT50 has additional power terminals A1 and A2.

Safety relay/expansion relay BT51(T)



6

Safety relay/expansion relay to Pluto

The BT51 is designed to connect safety devices, such as emergency stops, directly in the voltage supply circuit to the relay. Despite a maximum built-in width of 22.5 mm the relay is very powerful.

With 4 NO safety outputs, test input and complete internal supervising, the BT51 is quite unique. In addition you can order delayed outputs (BT51T).

In order for the safety outputs to close, the supply voltage, e.g. by means of an emergency stop button, must be connected to A1 and A2 and the test input closed. After actuation of the relay the test input can be opened again.

The test input is intended to supervise that contactors or valves have dropped/returned before a new start can be permitted. The test input can also be used for starting and the start button can be supervised (see connection example on next page).

More outputs

By connecting BT51 to a safety relay/PLC it is easy to increase the number of safe outputs. This means that an unlimited number of dangerous machine operations and functions can be stopped from one safety relay/PLC.

Safety level

BT50 has an internal redundant and monitored safety function. Power failure, internal component faults or external interference cannot result in dangerous functions.

Approvals:



Safety relay for:

- Emergency stop
- Interlocked hatch
- Expansion of Pluto

Features:

- Single and "dual" channel
- Test/"reset" input
- Width 22.5 mm
- LED indication
- 4 NO relay outputs
- Supply 24 VDC
- Quick release connector blocks
- BT51 - Additional power terminals
- BT51T - One changeover relay with a double information output (Y14)
- BT51T - Delay times selectable from 0 - 1.5 s

Input via A1 only is not protected from short circuiting, and therefore installation is critical for the safety level to be achieved. To achieve a higher safety level a screened cable can be used and/or connection made to both A1 and A2 (see example overleaf).

Regulations and standards

The BT51 is designed and approved in accordance with appropriate directives and standards. See technical data.

Connection examples

For examples of how our safety relays can solve various safety problems, please see the chapter "Connection examples".

Technical description – BT51(T)

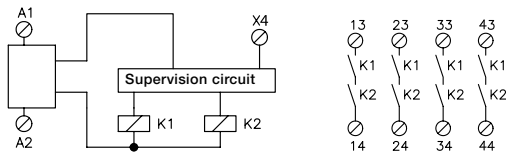

When supply voltage is connected to A1 and A2, relays K1 and K2 are activated. K1 and K2 drop if the supply voltage is disconnected. Both relays K1 and K2 must drop for them to be activated again. Another requirement is that the test circuit, A1 - X4, must be closed for the outputs to be activated. Thereafter A1 - X4 can either be open or constantly closed.

The supervising circuit ensures that both K1 and K2 have dropped before they can be reactivated. The stop function complies with the requirement that a component fault or external interference cannot lead to a dangerous function.

The safety outputs consist of contacts from K1 and K2 connected internally in series across terminals 13 - 14, 23 - 24, 33 - 34 and 43 - 44. These contacts are used to cut the power to components which stop or prevent hazardous movements/functions. It is recommended that all switched loads are adequately suppressed and/or fused in order to provide additional protection for the safety contacts.

BT51T - Info. output

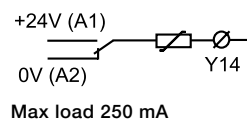

BT51T - Delay times

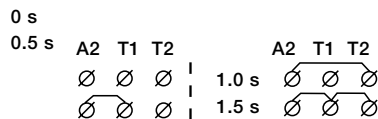

Electrical connection – BT51(T)

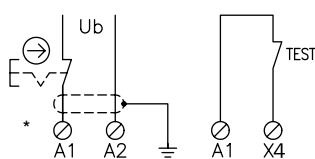

Emergency stop with reset when emergency button returns.

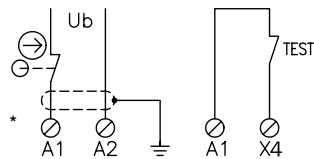

Hatch with automatic reset.

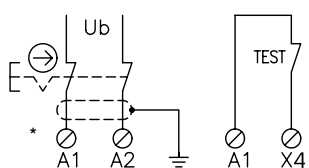

Emergency stop with dual connection direct to the supply voltage.

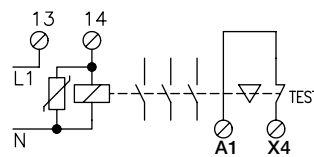

Controlled monitoring of external contactor, relay, valve or ABB Jobab Safety's expansion relays.

Technical data – BT51(T)

Article number	BT51 BT51T	2TLA010033R2000 2TLA010033R3000
Colour		Grey
Operational voltage		24 VDC + 15%/-25%
Power consumption		1.4 W/1.8 W
Relay Outputs		4 NO
Max. switching capacity		Resistive load AC 6A/250 VAC/1500 VA Inductive load AC AC15 240 VAC 2A Resistive load DC 6A/24 VDC/150 W Inductive load DC DC13 24 VDC 1A
Max. res. load total switching capacity		12 A distributed on all contacts
Min. load		10mA/10 V (if load on contact has not exceeded 100 mA)
Contact material		Ag + Au flash
Fuses Output (External)		5A gL/gG
Conditional short-circuit current (1 kA)		6A gG
Max Input Wire res. at nom. voltage		200 Ohms
Response time at deactivation		<20 ms or delayed max 1500 ms (BT51T)
Terminals (Max. screw torque 1 Nm)		Single strand: 2x1.5 mm ² Conductor with socket contact: 2x1 mm ²
Mounting		35 mm DIN-rail
Protection class enclosure/terminals		IP40 / IP20 IEC 60529
Impulse Withstand Voltage		2.5kV
Pollution Degree		2
Operating temperature range		-10°C to +55°C (with no icing or condensation)
Operating humidity range		35% to 85%
LED indication		Electrical Supply, Relay and X4
Weight		200 g
Performance (max.)		PL e/Cat. 4 (EN ISO 13849-1:2008) SIL 3 (EN 62061:2005) PFH _b 1.63E-08
Functional test: The relays must be cycled at least once a year.		
Conformity		2006/42/EC, 2006/95/EC, 2004/108/EC, EN 62061:2005 EN ISO 13849-1:2008

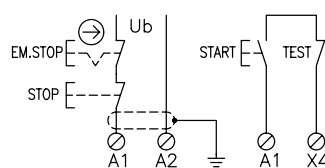

BT51 as emergency stop and control relay with Start and Stop function.

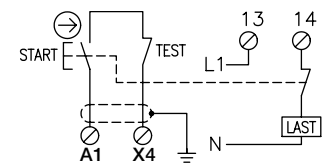

Monitoring to ensure that the On button is not stuck in pressed position. A short circuit over the closing contact is not monitored.

* BT51 has additional power terminals A1 and A2.

Safety relay JSBT5(T)



Approvals:



Safety relay for:

- Emergency stop
- Interlocked hatch

Features:

- Single and “dual” channel
- Test/start input
- Width 22.5 mm
- LED indication
- 3 NO/1NC relay outputs
- (T) = delayed outputs 0.5 sec.
- Supply 12 VDC, 24 VDC/AC

6

Single channel safety relay

The JSBT5 is designed to connect safety devices, such as emergency stops, directly in the voltage supply circuit to the relay. Despite a maximum built-in width of 22.5 mm the relay is very powerful.

With 3 NO safety outputs, 1 NC, test input and complete internal supervising, the JSBT5 is quite unique. In addition you can order delayed outputs (JSBT5T).

In order for the safety outputs to close, the supply voltage, e.g. by means of an emergency stop button, must be connected to A1 and A2 and the test input closed. After actuation of the relay the test input can be opened again.

The test input is intended to supervise that contactors or valves have dropped/returned before a new start can be permitted. The test input can also be used for starting and the start button can be supervised (see connection example on next page).

Safety level

The JSBT5 has a twin and supervised internal safety function. Power failure, internal component faults or external interference cannot result in dangerous functions.

Input via A1 only is not protected from short circuiting, and therefore installation is critical for the safety level to be achieved. To achieve a higher safety level a screened cable can be used and/or connection made to both A1 and A2 (see example overleaf).

Regulations and standards

The JSBT5 is designed and approved in accordance with appropriate directives and standards. See technical data.

Connection examples

For examples of how our safety relays can solve various safety problems, please see the section “Connection examples”.

Technical description – JSBT5(T)

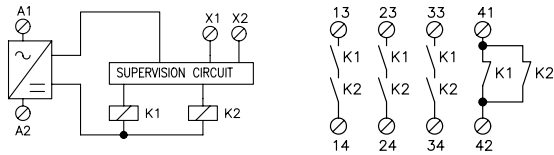

When supply voltage is connected to A1 and A2, relays K1 and K2 are activated. K1 and K2 drop if the supply voltage is disconnected. Both relays K1 and K2 must drop for them to be activated again. Another requirement is that the test circuit, X1 - X2, must be closed for the outputs to be activated. Thereafter X1 - X2 can either be open or constantly closed. The supervising circuit ensures that both K1 and K2 have dropped before they can be reactivated. The stop function complies with the requirement that a component fault or external interference cannot lead to a dangerous function.

The safety outputs consist of contacts from K1 and K2 connected internally in series across terminals 13 - 14, 23 - 24, and 33 - 34. These contacts are used to cut the power to components which stop or prevent hazardous movements/functions. It is recommended that all switched loads are adequately suppressed and/or fused in order to provide additional protection for the safety contacts.

The NC output 41 - 42 should only be used for monitoring purposes e.g. indication lamp for emergency stop pressed.

Electrical connection – JSBT5(T)

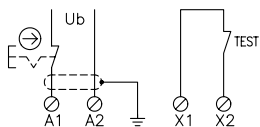

Emergency stop with automatic reset when emergency button returns.

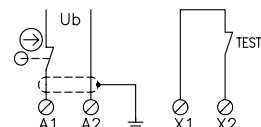

Hatch with automatic reset.

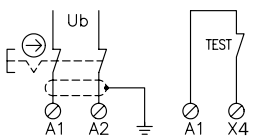

Emergency stop with dual connection direct to the supply voltage.

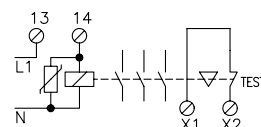

Controlled monitoring of external contactor, relay, valve or ABB Jokab safety's expansion relays.

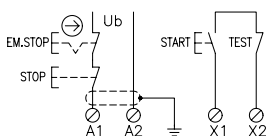

JSBT5 as emergency stop and control relay with Start and Stop function.

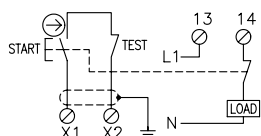

Monitoring to ensure that the On button is not stuck in pressed position. A short circuit over the closing contact is not monitored. The JSBR4 has built in short circuit monitored resetting.

Technical data – JSBT5(T)

Article number	JSBT5 24 VAC/VDC JSBT5 12 VDC JSBT5T 24 VAC/VDC	2TLA010005R0100 2TLA010005R0700 2TLA010005R1100
Colour		Grey
Operational voltage	JSBT5: JSBT5T:	24 VDC/AC + 15%–25%, 50–60 Hz 12 VDC, 24 VDC/AC + 15% – 25%, 50 - 60 Hz
Power consumption		1 W/1.9 VA
Relay Outputs		3 NO + 1 NC
Max. switching capacity	Resistive load AC Inductive load AC Resistive load DC Inductive load DC	6A/250 VAC/1500 VA AC15 240 VAC 2A 6A/24 VDC/150 W DC13 24 VDC 1A
Max. res. load total switching capacity:		9A distributed on all contacts
Min. load		10mA/10 V (if load on contact has not exceeded 100 mA)
Contact material		AgCuNi
Fuses Output (External)		5A gL/gG
Conditional short-circuit current (1 kA)		6A gG
Max Input Wire res. at nom. voltage		200 Ohm
Response time at deactivation		<60 ms or delayed max 500 ms (JSBT5T)
Terminals (Max. screw torque 1 Nm)	Single strand: Conductor with socket contact:	2x1.5 mm ² 2x1 mm ²
Mounting		35 mm DIN-rail
Protection class enclosure/terminals		IP40 / IP20 IEC 60529
Impulse Withstand Voltage		2.5kV
Pollution Degree		2
Operating temperature range		-10°C to +55°C (with no icing or condensation)
Operating humidity range		35% to 85%
Function indication		Electrical Supply
Weight		200 g
Performance (max.)	Functional test: The relays must be cycled at least once a year.	PL e/Cat. 4 (EN ISO 13849-1:2008) SIL 3 (EN 62061:2005) PFH _b 1.22E-08
Conformity		2006/42/EC, 2006/95/EC, 2004/108/EC, EN 62061:2005 EN ISO 13849-1:2008

Safety timer JSHT1



6

The JSHT1A/B closes two independent relay outputs during a guaranteed maximum time when the inputs are opened.

Time reset

Time reset can prevent unintentional reset of safety systems when someone is still in the dangerous area of the machine. During a guaranteed maximum time, one or several PB's for reset must be activated. The reset buttons should be sited in such a way that operatives have a clear overview of the whole area which is guarded. Time reset is made by the combination of a safety relay and the timer relay JSHT1A/B.

Time bypassing

The JSHT1 can also be used for time bypass of light beams for e.g. autotruck into a dangerous area.

Operation

When the inputs open the output contacts close. The output contacts open when the inputs close or when the time period has expired. The time period is hardwire selectable on terminals T1, T2 and T3. The time given is the maximum time. One or two channel operation is also hardwire selectable.

Regulations and standards

The JSHT1A/B is designed and approved in accordance with appropriate directives and standards. See technical data.

Connection examples

For examples of how our safety relays can solve various safety problems, please see the section "Connection examples".

Approvals:



Safety relay for:

- Time reset
- Time bypassing

Features:

- Hardwire time selection 5 – 40 s
- Selectable single or dual channel input
- Test input
- Width 45 mm
- LED indication for supply, inputs and outputs
- 1+1 NO relay outputs
- Supply 24 VDC
- Quick release connector blocks



Light beam being bypassed for a maximum pre-set time e.g. 5 sec. by the jsht1 during entrance and exit with the JSHD4 Three Position Enabling device.

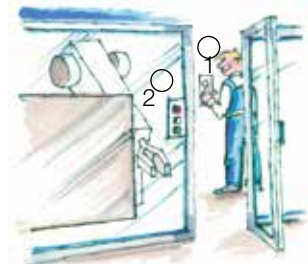

Time reset procedure. First push PB1, then exit dangerous area and close the door, then push PB2 (PB1 and PB2 must be pressed within the predetermined time period selected). After this procedure the machine can be safely restarted.

Technical description – JSHT1 A/B

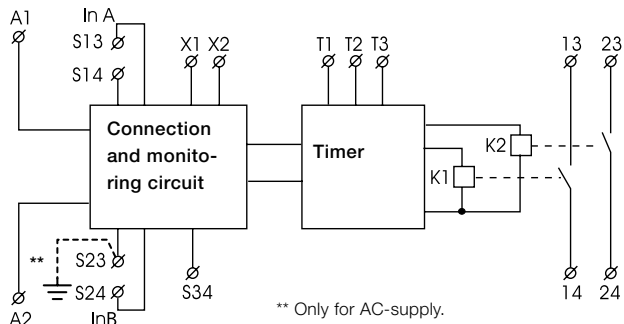

The electrical supply is connected across A1 and A2. The internal supervising circuit is activated directly when the supply is on. The inputs A and B must both be closed and then opened. Thereafter K1 and K2 are activated and the outputs close. K1 and K2 are activated for the hardwired selected time (set by connections on the terminals T1, T2 and T3). If there is a short circuit between the inputs or the inputs are closed again before the set time period has expired the outputs will open. In order to close the outputs again both the inputs have to be closed and both internal relays K1 and K2 deactivated (controlled by the supervising circuit) and the inputs again opened.

By external hardwire connections the JSHT1 can be made single or dual channel input. See figure below.

Electrical connection – JSHT1 A/B

Connection for single channel input

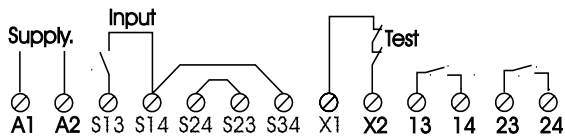

Connection for dual channel input

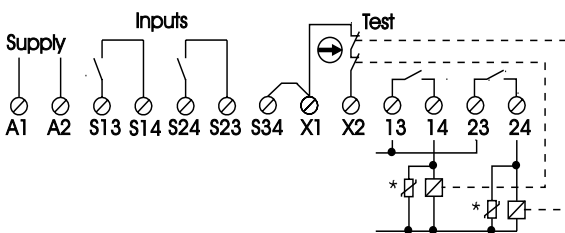

Selection of time by hardwire links

JSHT1A

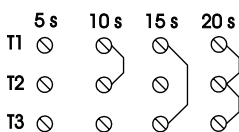

JSHT1B

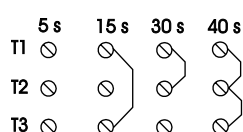

* It is recommended that all switched loads are adequately suppressed and/or fused in order to provide additional protection for the safety contacts. In the figure the monitoring of two contactors in the test input is shown.

Technical data – JSHT1 A/B

Article number	JSHT1A 24 VDC	2TLA010011R0000
	JSHT1B 24 VDC	2TLA010011R1000
Colour		Grey
Power supply		24 VDC $\pm 15\%$
Power consumption		1.8 W/3.7 VA
Max Input wire res. at nom voltage/channel		100/200 Ohm (1 Channel/ 2 Channel)
Response time at activation		<30ms
Response time at deactivation		< 15 ms
Selectable time ($\pm 15\%$ at nom. V.)		JSHT1A: 5-10-15-20 sec JSHT1B: 5-15-30-40 sec
Relay outputs		2 x 1 NO
Max. switching capacity resistive load AC		4A/250 VAC/1000 VA
Inductive load AC		AC15 250 VAC 3A
Resistive load DC		4A/24 VDC/100 W
Inductive load DC		DC13 24 VDC 2A
Max. total switching capacity:		8A distributed on all contacts
Min. load		10mA/10 V (if load on contact has not exceeded 100 mA)
Contact material		AgCuNi
Fuses output (external)		3A gL/gG or 4A fast
Conditional short-circuit current (1 kA)		6A gG
Max input wire res. at nom. voltage		100 Ohm
Terminals (max. screw torque 1 Nm)		
Single strand		1x4 mm ² , 2x1.5 mm ²
Conductor with socket contact		1x2.5 mm ² , 2x1 mm ²
Mounting		35 mm DIN-rail
Protection class enclosure/terminals		IP20 / IP40 IEC 60529
Impulse withstand voltage		2.5kV
Pollution degree		2
Operating temperature range		-10°C to +55°C (with no icing or condensation)
Operating humidity range		35% to 85%
LED indication		Electrical Supply, Inputs, Outputs
Weight		24 VDC: 330 g 24/48/115/230 VAC: 430 g
Performance (max.)		
Functional test: The relays must be cycled at least once a year.		PL e/Cat. 4 (EN ISO 13849-1:2008) SIL 3 (EN 62061:2005) PFH _d 4.42E-09
Conformity		2006/42/EC, 2006/95/EC, 2004/108/EC EN 62061:2005 EN ISO 13849-1:2008

Safety timer JSHT2



6

The JSHT2A/B/C closes two independent relay outputs during a guaranteed maximum period of time when the inputs are closed.

Time bypassing

Sensors detect the autocarrier and are connected to the JSHT2 which supervises the sensors and bypasses the light beam for a maximum predetermined time.

Inching

Inching applications require safety outputs to be closed for a predetermined maximum period of time, allowing the machine to move only a short distance each time the inching control is activated. For each new motion the inching control e.g. PB or pedal must be released and activated again.

Operation

When the inputs close the output contacts close. The output contacts open when the input opens or when the time period has expired. The time is hardwire selectable on the terminals T1, T2 and T3. The time given is the maximum time. Single or dual channel operation is also hardwire selectable.

Regulations and standards

The JSHT2A/B/C is designed and approved in accordance with appropriate directives and standards. See technical data.

Connection examples

For examples of how our safety relays can solve various safety problems, please see the section "Connection examples".

Approvals:



Safety relay for:

- Time bypassing
- Inching

Features:

- Hardwire time selection
- 0.2 – 40 s
- Selectable single or dual channel input
- Test input
- Width 45 mm
- LED indication for supply, inputs and outputs
- 1+1 NO relay outputs
- Supply 24 VDC
- Quick release connector blocks

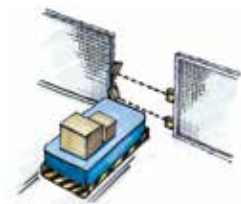

Light beam being bypassed only for the time it takes the autocarrier to pass.



Shaft only turns a small amount each time the PB is pressed.

Technical description – JSHT2 A/B/C

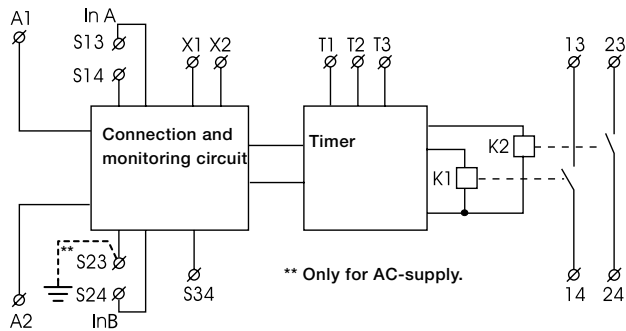

The electrical supply is connected across A1 and A2. The internal supervising circuit is activated directly when the supply is on. The inputs A and B must both be opened and then closed. Thereafter K1 and K2 are activated and the outputs close. K1 and K2 are activated for hardwired selected time (set by connections on the terminals T1, T2 and T3). If there is a short circuit between the inputs or the inputs are opened again before the set time period has expired the outputs will open. In order to close the outputs again both the inputs have to be opened and both internal relays K1 and K2 deactivated (controlled by the supervising circuit) and then the inputs closed again.

By external hardware connectors the JSHT2 can be made to operate from either single or dual channel inputs. See figure below.

Electrical connection – JSHT2 A/B/C

Connection for single channel input

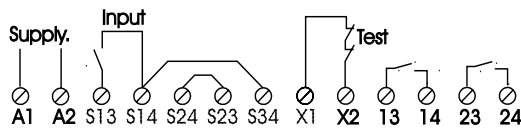

Selection of time by hardwire links

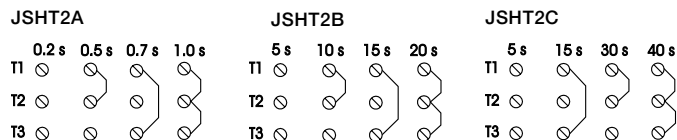

Connection for dual channel input

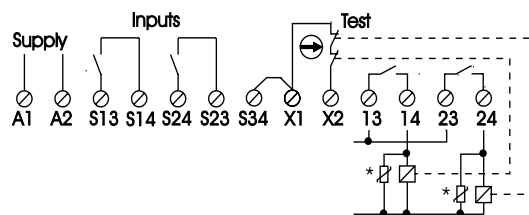

* It is recommended that all switched loads are adequately suppressed and/or fused in order to provide additional protection for the safety contacts. In the figure the monitoring of two contactors in the test input is shown.

Technical data – JSHT2 A/B/C

Article number	
JSHT2A 240 VDC	2TLA010012R0000
JSHT2B 24 VDC	2TLA010012R1000
JSHT2C 24 VDC	2TLA010012R2000
Colour	
Grey	
Power supply	
24 VDC \pm 15 %	
Power consumption	
1.8 W/3.8 VA	
Max input wire res. at nom voltage/channel	
100/200 Ohm (1 Channel/ 2 Channel)	
Response time at activation	
< 30 ms	
Response time at deactivation	
< 15 ms	
Selectable time (\pm 15 % at nom. V.)	
JSHT2A: 0.2 - 0.5 - 0.7 - 1.0 sec	
JSHT2B: 5 - 10 - 15 - 20 sec	
JSHT2C: 5 - 15 - 30 - 40 sec	
Relay outputs	
2 x 1 NO	
Max. switching capacity	
Resistive load AC	4A/250 VAC/1000 VA
Inductive load AC	AC15 250VAC 3A
Resistive load DC	4A/24 VDC/100 W
Inductive load DC	DC13 24VDC 2A
Max. total switching capacity:	
8A distributed on all contacts	
Min. load	
10mA/10 V (if load on contact has not exceeded 100 mA)	
Contact material	
AgCuNi	
Fuses output (external)	
3A gL/gG or 4A fast	
Max input wire res. at nom. voltage	
100 Ohm	
Terminals (max. screw torque 1 Nm)	
Single strand:	1x4 mm ² or 2x1.5 mm ²
Conductor with socket contact:	1x2.5 mm ² or 2x1 mm ²
Mounting	
35 mm DIN-rail	
Protection class	
IP20 / IP40 IEC 60529	
Impulse withstand voltage	
2.5kV	
Pollution degree	
2	
Operating temperature range	
-10°C to +55°C (with no icing or condensation)	
Operating humidity range	
35% to 85%	
LED indication	
Electrical Supply, Inputs, Outputs	
Weight	
24 VDC: 310 g	
24/48/115/230 VAC: 410 g.	
Performance (max.)	
Functional test: The relays must be cycled at least once a year.	PL e/Cat. 4 (EN ISO 13849-1:2008) SIL 3 (EN 62061:2005) PFH _D 4.42E-09
Conformity	
2006/42/EC, 2006/95/EC, 2004/108/EC EN 62061:2005 EN ISO 13849-1:2008	

Expansion relay E1T



6

More outputs

By connecting expansion relays to a safety relay it is easy to increase the number of safe outputs. This means that an unlimited number of dangerous machine operations and functions can be stopped from one safety relay.

Safe soft stop

When a gate is opened a program stop is first given to the machine's PLC/servo which brakes the dangerous operations in a soft and controlled way. The safety outputs then break the power to the motors, that is, when the machine has already stopped. Normally between 0.5 and 1 second is needed to brake a dangerous machine operation softly.

Soft stop ensures many advantages:

- The machine lasts longer.
- Parts being processed are not damaged.
- Restart from stopped position is enabled and simplified.

A safe soft stop is achieved by means of a safety relay which gives the program stop, and an expansion relay, E1T, which gives safe delayed stop signals. See section "Connection examples". The drop time delay on a E1T can as standard be selected from 0 to 3 seconds. By connecting several E1T's in series even longer times can be achieved.

When are delayed safe stops used?

Delayed safety stop signals can be used for emergency stops according to EN ISO 13850:2008 § 4.1.4. Stop category 1, i.e. a controlled stop with power to the actuator(s) available to achieve the stop and then removal of power when stop is achieved.

Approvals:



Safety relay for:

- More safety outputs
- Delayed safety outputs

Features:

- Width 22.5 mm
- Supply 24 VDC
- LED output indication
- 4 NO relay outputs
- Single or dual channel operation option
- Quick release connector blocks

Stop category 1 may also be permitted when it is not possible to gain physical access to the machine before the safe stop is affected e.g:

- Gates, access time is normally over 1 sec.
- Covers and gates which are locked until dangerous operations and functions have been stopped.
- Long distances between a safety device and a dangerous machine function.

Safety level

The E1T has twin stop functions, that is, two relays with mechanically operated contacts. A monitored stop function is achieved by connecting the test output (terminals X1 and X2) to the test or reset input on the safety relay which is being expanded.

One condition for a safe delayed stop is that the delay time cannot increase in the event of a fault. The E1T complies with this requirement.

Regulations and standards

The E1T is designed and approved in accordance with appropriate directives and standards. See technical data.

Connection examples

For examples of how our safety relays can solve various safety problems, please see the section "Connection examples".

Technical description – E1T

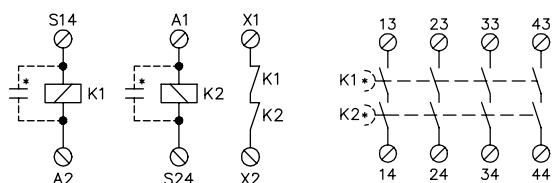

The E1T has to be connected to a safety relay in order to fulfill the necessary safety requirements (see connection examples below). The safety relay controls and monitors the E1T (The E1T can be connected for single or dual channel operation - see below). When the inputs S14 and S24 close, relays K1 and K2 are activated. A stop signal is given, K1 and K2 drop, if the inputs are opened or during power failure. K1 and K2 drop either directly or after a delay* (if incorporated). Delay time of module is fixed and shown on front panel of device. The delay circuit is so arranged that the design time cannot be exceeded.

To check that both the relays K1 and K2 drop during a stop signal they must be monitored. This is achieved by connecting X1 and X2 to the test or reset input on the safety relay which is expanded (see below). K1 and K2 are mechanically operated relays, therefore, if one of the output contacts should stick closed then the relay's contact in X1-X2 cannot be closed thus preventing a new ready signal being given to the safety relay.

Inductive loads should be equipped with an arc suppressor to protect the output contacts.

Diodes are the best arc suppressors but will increase the switch off time of the load.

Electrical connection – E1T

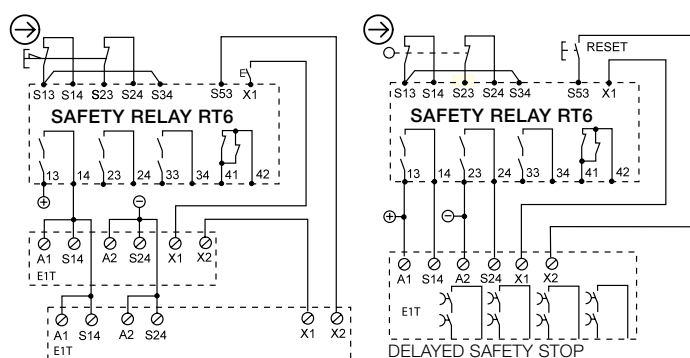

Single channel expansion of outputs for a safety relay connected to an emergency stop.

Dual channel expansion with delayed safety outputs for a safety relay monitoring a gate.

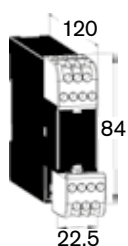

Connector blocks are detachable (without cables having to be disconnected)

Technical data – E1T

Article number	E1T 0 s 24 VDC E1T 0.5 s 24 VDC E1T 1 s 24 VDC E1T 1.5 s 24 VDC E1T 2 s 24 VDC E1T 3 s 24 VDC	2TLA010030R0000 2TLA010030R1000 2TLA010030R2000 2TLA010030R3000 2TLA010030R4000 2TLA010030R5000
Colour		Grey
Operational voltage		24 VDC ± 15%
Power consumption		1.5 W
Relay Outputs		4 NO
Max. switching capacity		
Resistive load AC		6A/250 VAC/1500VA
Inductive load AC		AC15 240 VAC 2A
Resistive load DC		6A/24 VDC/150W
Inductive load DC		DC13 24 VDC 1A
Max. total switching capacity		12A distributed on all contacts
Min. switching load		10 mA/10 V (if load on contact has not exceeded 100 mA)
Contact material		Ag + Au flash
Fuses output (external)		5A gL/gG
Conditional short-circuit current (1 kA)		6A gG
Maximum external resistance at a nominal voltage		150 Ohm (S14, S24)
Response time at deactivation (input - output)		< 0,020 s, 0,5 s, 1 s, 1,5 s, 2 s, 3 s, ± 20%
Response time at activation (input-output)		<30 ms
Terminals (max. screw torque 1 Nm)		
Single strand:		1x4 mm ² / 2x1.5 mm ²
Conductor with socket contact:		1x2.5 mm ² / 2x1 mm ²
Mounting		35 mm DIN-rail
Protection class		
enclosure		IP40 IEC 60529
terminals		IP20 IEC 60529
Impulse withstand voltage		2.5kV
Pollution degree		2
Operating temperature range		-10°C – +55°C (with no icing or condensation)
Operating humidity range		35% to 85%
LED indication		Output status
Weight		220 g
Performance (max.)		PL e/Cat. 4
Functional test: The relays must be cycled at least once a year.		(EN ISO 13849-1:2008) SIL 3 (EN 62061:2005) PFH ₀ 1.55E-08
Conformity		2006/42/EC, 2006/95/EC, 2004/108/EC EN 62061:2005 EN ISO 13849-1:2008

Expansion relay JSR1T



Approvals:



Safety relay for:

- More safe outputs
- Delayed safe outputs
- Information output

Features:

- Width 45 mm
- Supply 24 VDC
- LED function indication
- 4 NO/1 NC relay outputs
- Single and dual channel
- Quick release connector blocks

More outputs

By connecting expansion relays to a safety relay it is easy to increase the number of safe outputs. This means that an unlimited number of dangerous machine operations and functions can be stopped from one safety relay.

Safe soft stop

When a gate is opened a program stop is first given to the machine's PLC/servo which brakes the dangerous operations in a soft and controlled way. The safety outputs then break the power to the motors, that is, when the machine has already stopped. Normally between 0.5 and 1 second is needed to brake a dangerous machine operation softly.

Soft stop ensures many advantages:

- The machine lasts longer.
- Parts being processed are not damaged.
- Restart from stopped position is enabled and simplified.

A safe soft stop is achieved by means of a safety relay which gives the program stop, and an expansion relay, JSR1T, which gives safe delayed stop signals. See section "Connection examples". The drop time delay on a JSR1T can as standard be selected from 0 to 10 seconds. By connecting several JSR1T's in series even longer times can be achieved.

When are delayed safe stops used?

Delayed safety stop signals can be used for emergency stops according to EN418 § 4.1.4 Stop category 1, i.e. a controlled stop with power to the actuator(s) available to achieve the stop and then removal of power when stop is achieved.

Stop category 1 may also be permitted when it is not possible to gain physical access to the machine before the safe stop is affected e.g:

- Gates, access time is normally over 1 sec.
- Covers and gates which are locked until dangerous operations and functions have been stopped.
- Long distances between a safety device and a dangerous machine function.

Safety level

The JSR1T has twin stop functions, that is, two relays with mechanically operated contacts. A monitored stop function is achieved by connecting the test output (terminals X1 and X2) to the test or reset input on the safety relay which is being expanded.

One condition for a safe delayed stop is that the delay time cannot increase in the event of a fault. The JSR1T complies with this requirement.

Regulations and standards

The JSR1T is designed and approved in accordance with appropriate directives and standards. See technical data.

Connection examples

For examples of how our safety relays can solve various safety problems, please see the section "Connection examples".

Technical description – JSR1T

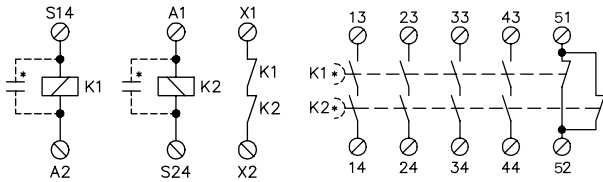

The JSR1T has to be connected to a safety relay in order to fulfill the necessary safety requirements (see connection examples below). The safety relay controls and monitors the JSR1T. (The JSR1T can be connected for single or dual channel operation - see below). When the inputs S14 and S24 close, relays K1 and K2 are activated. A stop signal is given, K1 and K2 drop, if the inputs are opened or during power failure. K1 and K2 drop either directly or after a delay* (If incorporated). Delay time of module is fixed and shown on front panel of device. The delay circuit is so arranged that the design time cannot be exceeded.

To check that both the relays K1 and K2 drop during a stop signal they must be monitored. This is achieved by connecting X1 and X2 to the test or reset input on the safety relay which is expanded (see below). K1 and K2 are mechanically operated relays, therefore, if one of the output contacts should stick closed then the relay's contact in X1-X2 cannot be closed thus preventing a new ready signal being given to the safety relay.

Inductive loads should be equipped with an arc suppressor to protect the output contacts.

Diodes are the best arc suppressors but will increase the switch off time of the load.

Electrical connection – JSR1T

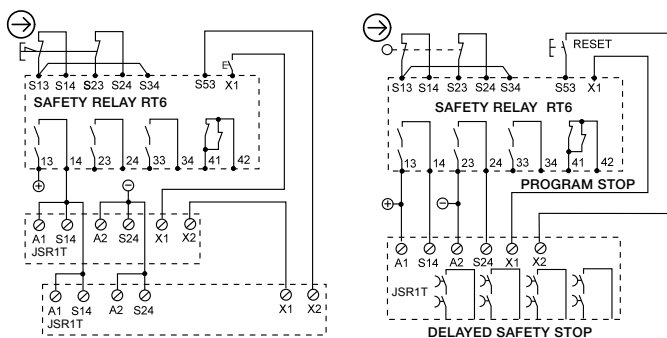

Expansion of outputs for safety relay connected to emergency stop with automatic reset.

Dual-channel expansion with delayed safety outputs for safety relay monitoring a gate.

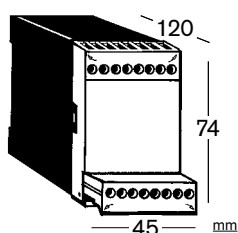

Connector blocks are detachable (without cables having to be disconnected)

Technical data – JSR1T

Article number	
JSR1T 0	2TLA010015R0000
JSR1T 1.5	2TLA010015R0500
JSR1T 8	2TLA010015R0600
JSR1T 0.5	2TLA010015R1000
JSR1T 10s	2TLA010015R2000
JSR1T 1	2TLA010015R3000
JSR1T 2	2TLA010015R4000
JSR1T 3	2TLA010015R5000
JSR1T 5	2TLA010015R6000
Colour	Grey
Power supply	24 VDC ±15%
Power consumption	1.2 W
Relay outputs	4 NO + 1 NC
Max. switching capacity	
Resistive load AC	6A/250 VAC/1500 VA
Inductive load AC	AC15 240 VAC 2A
Resistive load DC	6A/24 VDC/150 W
Inductive load DC	DC13 24 VDC 1A
Max. total switching capacity:	16A distributed on all contacts
Min. load	10mA/10 V (if load on contact has not exceeded 100 mA)
Contact material	Ag + Au flash
Fuses output (external)	5A gL/gG
Conditional short-circuit current (1 kA)	6A gG
Max. Input wire res. at nom. voltage	150 Ohm (S14, S24)
Response time at deactivation (input- output)	< 0.020 s, 0.5 s, 1 s, 1.5 s, 2 s, 3 s, 5 s, 8 s, 10 s ± 20 %
Terminals (max. screw torque 1 Nm)	
Single strand:	1x2.5 mm ² / 2x1 mm ²
Conductor with socket contact:	1x4 mm ² / 2x1.5 mm ²
Mounting	35 mm DIN-rail
Protection class enclosure/terminals	IP40 / IP20 IEC 60529
Impulse withstand voltage	2.5kV
Pollution degree	2
Operating temperature range	-10°C to +55°C (with no icing or condensation)
Operating humidity range	35% to 85%
LED indication	Output Relay Supplies
Weight	280 g
Performance (max.)	PL e/Cat. 4 (EN ISO 13849-1:2008)
Functional test: The relays must be cycled at least once a year	SIL 3 (EN 62061:2005) PFH _D 1.55E-08
Conformity	2006/42/EC, 2006/95/EC, 2004/108/EC EN 62061:2005 EN ISO 13849-1:2008

Expansion relay JSR2A



6

More outputs

The JSR2A expansion relay is used to provide increased switching capacity and number of safety outputs to a safety relay. This means that an unlimited number of dangerous machine operations and functions can be stopped from one safety relay.

Greater current switching capacity

The JSR2A Expansion relay enables switching of up to 10 amps per output contact.

Safety level

The JSR2A has twin stop functions, that is, two relays with mechanically positively guided contacts. A monitored stop function is achieved by connecting the test output (terminals X1 and X2) to the test or reset input on the safety relay which is to be expanded.

Regulations and standards

The JSR2A is designed and approved in accordance with appropriate directives and standards. See technical data.

Connection examples

For examples of how our safety relays can solve various safety problems, please see the section “Connection examples”.

Approvals:



Safety relay for:

- More safe outputs
- Greater current switching capacity
- Information output

Features:

- Switching capacity of up to 10 A/250V per output
- Width 45 mm
- LED function indication
- 4 NO/1 NC relay outputs
- 5 supply versions
- Supply 24 VDC/VAC, 115 and 230 VAC
- Quick release connector blocks

Technical description – JSR2A

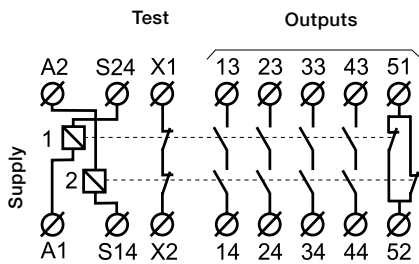

The JSR2A has to be connected to a suitable safety relay in order to fulfill the necessary safety requirements (see chapter “Connection examples”). The Safety Relay controls and monitors the JSR2A unit. (The JSR2A can be connected for single or dual channel operation - see Electrical connection diagrams below). When the inputs to S14 and S24 close, internal relays K1 and K2 are activated. A stop signal is given, K1 and K2 drop, if the inputs are opened or during power failure.

To check that both the K1 and K2 relays drop during a stop signal they must be monitored. This is achieved by connecting X1 and X2 to the test or reset input on the safety relay which is expanded. K1 and K2 have mechanically positively guided contacts, therefore, if one of the output contacts should stick closed then the relay’s contact in X1-X2 cannot be closed thus preventing a new ready signal being given to the safety relay.

Electrical connection – JSR2A

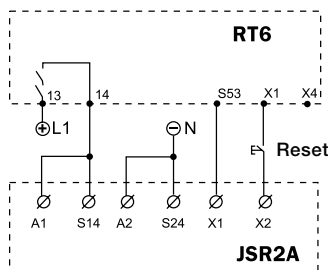

One channel expansion of RT6 with JSR2A connected for manual reset.

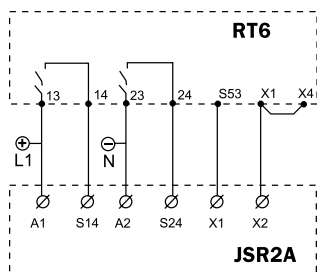

Dual channel expansion of RT6 with JSR2A connected for automatic reset.

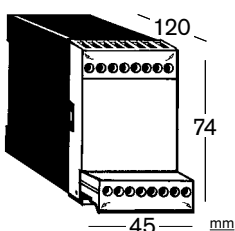

Connector blocks are detachable (without cables having to be disconnected)

Technical data – JSR2A

Article number	JSR2A 10 A 24 VAC/VDC	2TLA010027R0100
	JSR2A 10 A 115 VAC	2TLA010027R0400
	JSR2A 10 A 230 VAC	2TLA010027R0500
Colour	Grey	
Supply A1 - A2	24 VDC/AC, 115, 230 VAC + 15%, 50-60 Hz	
Power consumption	2.7W/2.4-4 VA	
Relay outputs	4 NO + 1 NC	
Max. switching capacity		
Resistive load AC	8A/230 VAC/1840 VA 10A/115VAC/48VAC/24VAC/ 1840 VA	
Inductive load AC	AC15 230 VAC 4A (NO-contact) 1.5A (NC-contact)	
Resistive load DC	8A/24 VDC/192 W	
Inductive load DC	DC13 24 VDC 1.2A (NO/NC-contact)	
Max. total switching capacity:	16A distributed on all contacts	
Min. load	10mA/10V/100mW (if load on contact has not exceeded 100 mA)	
Contact material	AgSnO ₂ + Au flash	
Fuses output (External)	6A gL (8A fast if short-circuit current >500A)	
Conditional short-circuit current (1 kA)	10A gG	
Max. Input wire res. at nom. voltage	24 VDC/VAC: 100 Ohm 48/115/230 VAC: 200 Ohm	
Mechanical operational Life	>10 ⁷ operations	
Response time at		
deactivation (input- output)	<25 ms	
activation (input - output):	<15 ms	
Terminals (removable)		
Max. screw torque	1 Nm	
Connection area (max.)		
Single strand	1x4 mm ² or 2x1.5 mm ² / 12AWG	
Conductor with socket contact	1x2.5 mm ² or 2x1 mm ²	
Mounting	35 mm DIN-rail	
Protection class terminals		
Enclosure	IP40 IEC 60529	
Terminals	IP20 IEC 60529	
LED indication		
On <input type="radio"/>	Supply voltage	
<input checked="" type="checkbox"/> <input type="radio"/> 1 <input checked="" type="checkbox"/> <input type="radio"/> 2	Output relays 1 and 2	
Impulse withstand voltage	2.5kV	
Pollution degree	2	
Operating temperature range	-10°C to +55°C (with no icing or condensation)	
Operating humidity range	35% to 85%	
Weight	313 g	
Performance (max.)	PL e/Cat. 4	
Functional test: The relays must be cycled at least once a year	(EN ISO 13849-1:2008) SIL 3 (EN 62061:2005) PFH _d 1.55E-08	
Conformity	2006/42/EC, 2006/95/EC, 2004/108/EC EN 62061:2005 EN ISO 13849-1:2008	

Expansion relay JSR3T



Approvals:



Safety relay for:

- Safe delay of stop signals with selectable value
- Delayed safe outputs

Features:

- Width 22.5 mm
- Supply 24V AC/DC
- Output indication
- 2 x 1 NO relay outputs
- Hardwire Selectable
Delay 0.5 - 10.0 sec by
hardwire links and Time trim
potentiometer

6

Delayed outputs

By connecting the JSR3T expansion relay to a compatible Safety relay it is easy to obtain safe "delayed" outputs.

The JSR3T provides the system designer with the facility to hardwire selected time delays in steps between 0.5 and 10 seconds.

Use of delayed outputs

There are many applications where delayed outputs are necessary and permissible. For example delayed stop signals can be used for emergency stops according to EN ISO 13850:2008 § 4.1.4 Stop Category 1 (a controlled stop with power to the machine actuator(s) available to achieve the stop and then removal of power when stop is achieved). Stop Category 1 may also be permitted when it is not possible to gain physical access to the machine before the safe stop is effected e.g. by:

- Covers and Gates which are locked until dangerous operations and functions have been stopped.
- Long distances between a safety device and dangerous machine functions.
- Using this technique of stopping a machine provides many advantages i.e.:
- Machines last longer as they are not subjected to excessive loading etc when requested to stop.
- Parts being processed are not damaged.
- Restarting machines from stopped position is simplified.

A safe "Soft" stop is achieved by means of a safety relay giving a programme stop to the machine control system. e.g. when a gate is opened or emergency stop is activated. The output of the Safety relay is used to provide both a stop signal

to the machine control system i.e. via a PLC which applies the necessary braking/stopping of the machine in a controlled way, and to switch a delayed expansion relay e.g JSR3T. The delayed safety outputs of the JSR3T expansion relay are then used to control the safe disconnection of the power to the actuators/motors etc. of the machine.

Safety level

The JSR3T has twin stop functions, using two positively guided contact relays.

In order to achieve the level of monitoring required the JSR3T must be used with a suitable Safety Relay e.g. JSBR4, or RT6. The JSR3T test output (terminals X1 and X2) must be connected to the test input of the Safety relay being expanded (see connection examples).

The JSR3T provides delay times that even in the event of an internal fault condition complies with the requirement that the set delay cannot increase in time.

Regulations and standards

The JSR3T is designed and approved in accordance with appropriate directives and standards. Examples of such are 98/37/EC, EN ISO 12100-1/-2, EN 60204-1, EN 954-1/ EN ISO 13849-1.

Connection examples

For examples of how our safety relays can solve various safety problems, please see the section "Connection examples".

Technical description – JSR3T

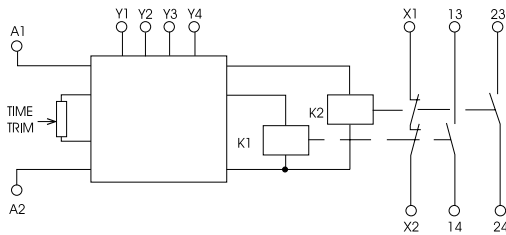

When supply voltage is connected to A1 and A2, relays K1 and K2 are activated. When the supply voltage is removed relays K1 and K2 remain energized for a time period determined by the hardwire link configuration chosen (set by connecting links on the terminals Y1, Y2, Y3 and Y4.) and the setting of the Time Trim potentiometer.

NOTE 1! Max. time set by hardwire links can only be reduced (up to approx. 30% reduction) by Time Trim potentiometer.

NOTE 2! Both the output contacts of K1 and K2 (13 - 14 and 23 - 24) must be used. Output contacts must be either connected in series (forming one safety output) or used in parallel circuits in order to obtain necessary redundancy.

Electrical connection – JSR3T

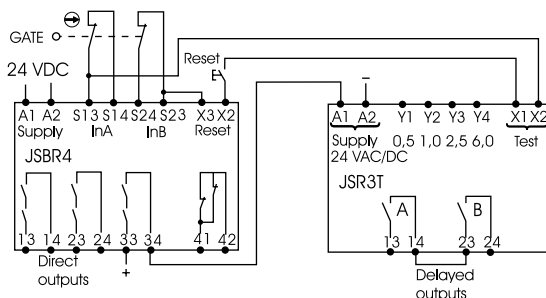
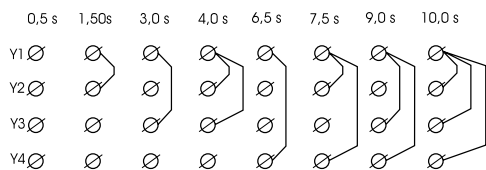
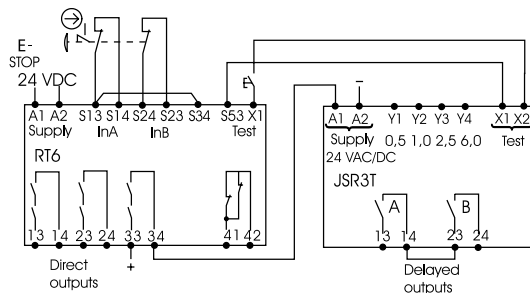

Technical data – JSR3T

Article number	JSR3T 24 VAC/VDC	2TLA010017R0100
Colour		Grey
Power supply		24 VAC/VDC, 50 - 60 Hz
Power consumption		1.3 VA/W
Relay outputs		2 x 1 NO (See Connection examples)
Max. switching capacity		Resistive load AC 4A / 250 VAC/1000 VA Inductive load AC AC15 240 VAC 3A Resistive load DC 4A / 24 VDC /100 W Inductive load DC DC13 24 VDC 2A
Max. res. load total switching capacity:		6A distributed on all contacts
Min. load		10mA/10V (if load on contact has not exceeded 100 mA)
Contact material		AgNi
Fuses output (external)		3A gL/gG or 4A fast
Conditional short-circuit current (1 kA)		6A gG
Max Input wire res. at nom. voltage		100 Ohm
Response time at activation		<20ms
Response time at deactivation		<0.5 - 10.0 sec. at nom. voltage. Selected delay can be lowered by up to approx. 30% by means of preset potentiometer on front panel.
Terminals (max. screw torque 1 Nm)		Single strand: 2x1.5 mm ² Conductor with socket contact: 2x1mm ² .
Mounting		35 mm DIN-rail
Protection class enclosure/terminals		IP40 / IP20 IEC 60529
Impulse withstand voltage		2.5kV
Pollution degree		2
Operating temperature range		-10°C to +55°C (with no icing or condensation)
Operating humidity range		35% to 85%
LED indication		Outputs
Weight		158 g
Performance (max.)		PL e/Cat. 4
Functional test: The relays must be cycled at least once a year.		(EN ISO 13849-1:2008) SIL 3 (EN 62061:2005) PFH _D 3.67E-09
Conformity		2006/42/EC, 2006/95/EC, 2004/108/EC EN 62061:2005 EN ISO 13849-1:2008

Selection of time delay by hardwire links (Y1, Y2, Y3, Y4).

Selected delay can be lowered by up to approx. 30% by means of preset potentiometer on front panel.

It is recommended that all switched loads are adequately suppressed and/or fused in order to provide additional protection for the safety contacts.

Connection examples

HA5400A Connection examples JSBR4	6/45
HA6400A Connection examples JSBT4	6/45
HA6500A Connection examples JSBT5	6/46
HA6500B Connection examples BT50	6/46
HA6501B Connection examples BT50T	6/47
HA6500C Connection examples BT51	6/47
HA6501C Connection examples BT51T	6/48
HA7100A Connection examples JSBRT11	6/48
HA7600A Connection examples RT6	6/49
HA7600B Principle drawing RT6	6/49
HA7672A Enabling device JSHD4 - EX with RT6	6/50
HA7700A Connection examples RT7	6/50
HA7900A Connection examples RT9	6/51
HE3811B Safety Light Beam Spot with time-limited reset	6/51
HE3824C-01 Lightbeam with time-limited bypass 0.2–40 s	6/52
HE3824E-01 Lightbeams with time-limited bypass 0.2–40 s	6/52
HG7636B Focus light grid/curtain with three-position device	6/53
HG7611A Interlocked door with RT6 and pre-reset	6/53
HG7636A Interlocked door with three-position device	6/54
HG7646A Interlocked door with three-position device	6/54
HG7654A Interlocked door with RT6 and output expansion JSR1T	6/55
HG7658A Interlocked door with RT6 and output expansion JSR2A	6/55
HG7673A Interlock switch JSNY8 with RT6	6/56
HG7674A Safety interlock switch JSNY9M/MLA with RT6	6/56
HG7674B Safety interlock switch JSNY9S/SLA with RT6	6/57
HH0000C Three-position device JSHD4 with various safety controllers	6/57
HI8552A Connection examples JSHT2 intermittent running	6/58
HK7600A Safety mat/Contact strip with RT6	6/58
HL7600B Several JSNY7 connected to one RT6 with unique indication	6/59
HM0000A Magnetic switch JSNY7 with various safety controllers	6/59
HN7660A Delayed outputs RT6 with output expansion JSR3T and RT7	6/60
HP7600A Machine control - Isolation of PLC inputs and outputs	6/60
HP7600B Machine control-Isolation of PLC outputs	6/61
HR7200B Focus light curtain/beam	6/61
HR7800B Focus lightbeam/curtain	6/62
HT5400A Two-hand device with safety relay JSBR4	6/62
HB0008A Focus light curtain/light beam with RT9 and M12-3D	6/63

Connection examples

HA5400A Connection examples JSBR4

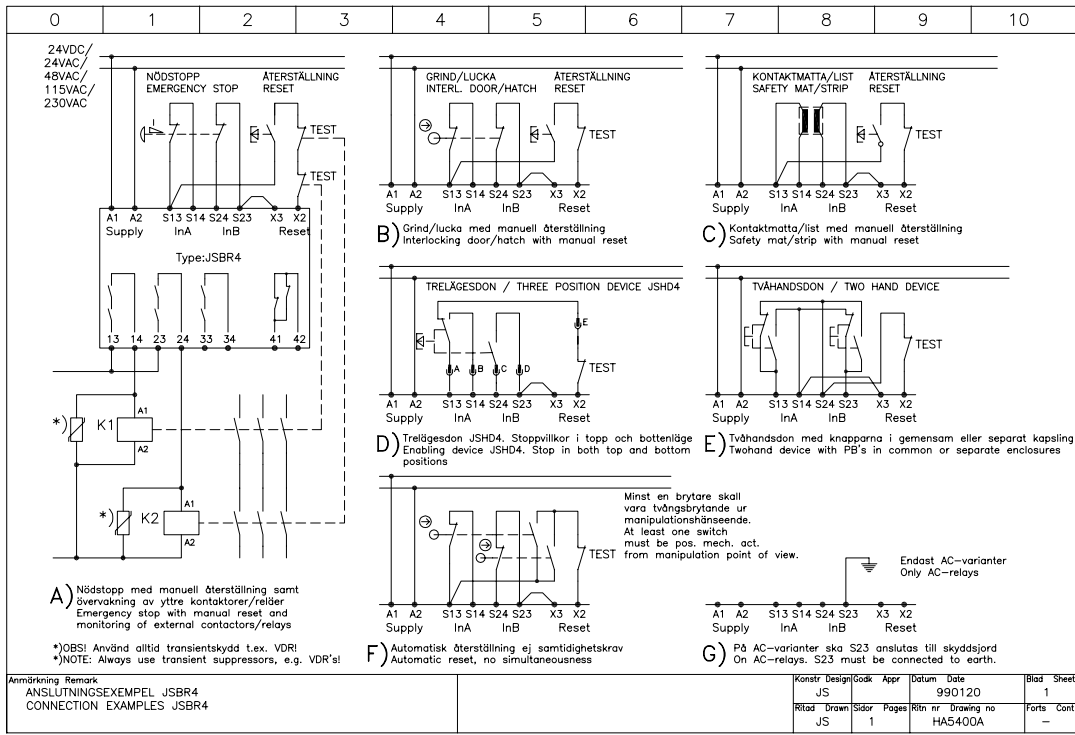

HA6400A Connection examples JSBT4

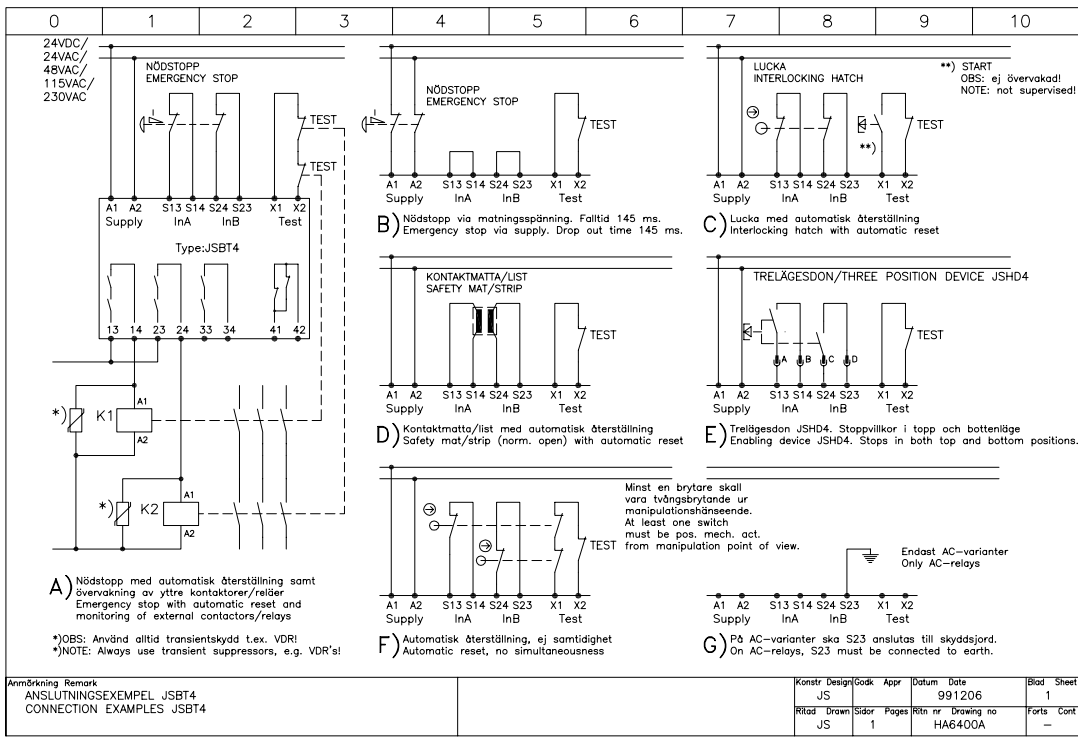

Connection examples

HA6500A Connection examples JSBT5

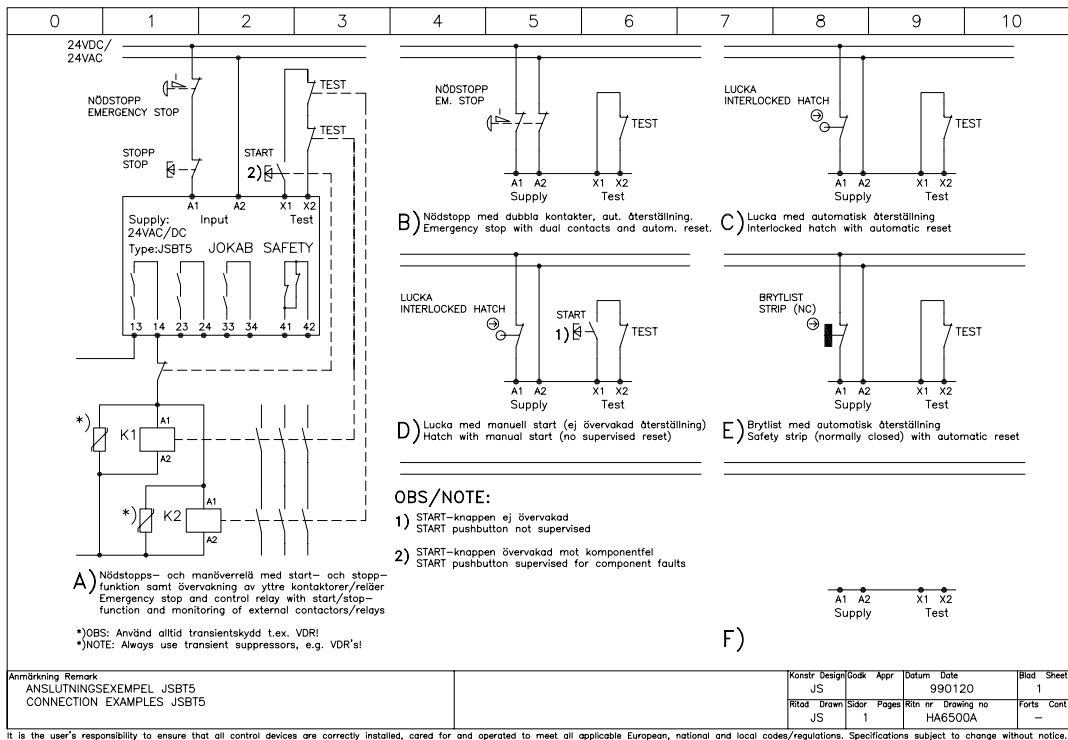

HA6500B Connection examples BT50

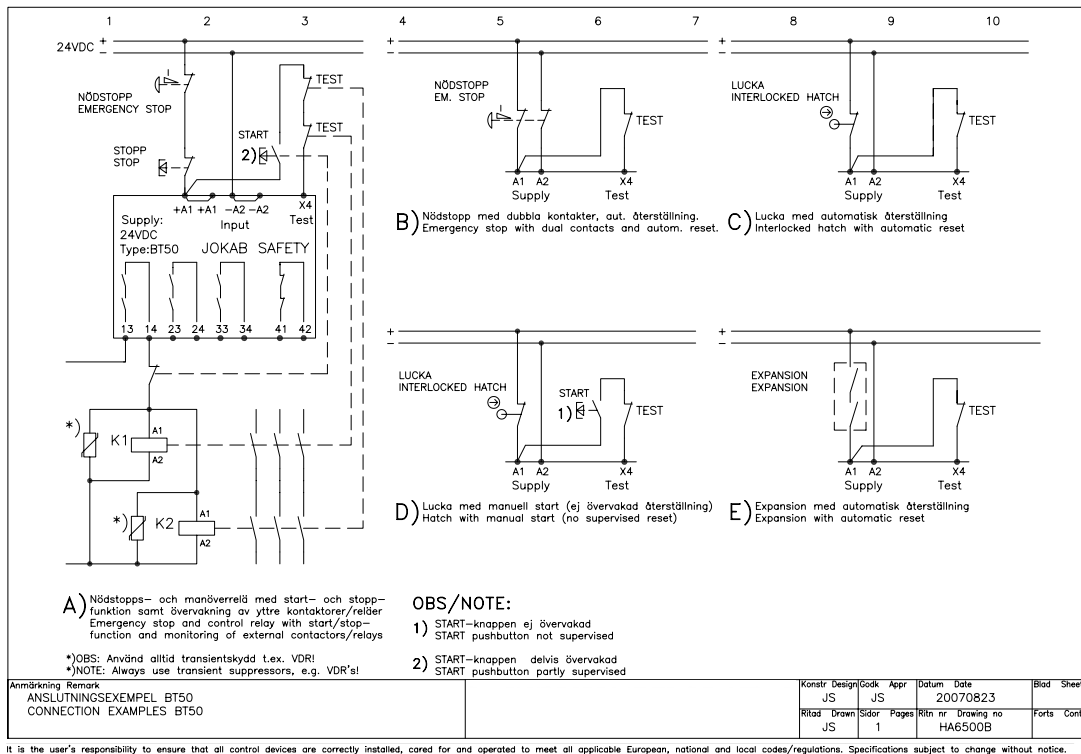

Connection examples

HA6501B Connection examples BT50T

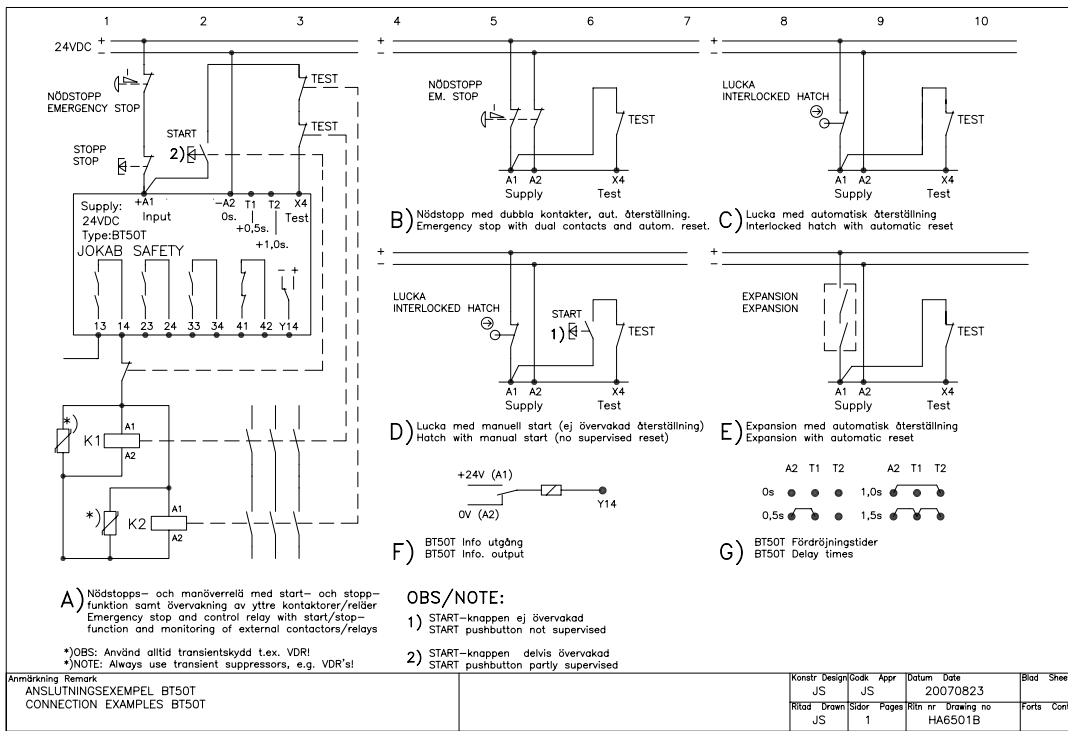

HA6500C Connection examples BT51

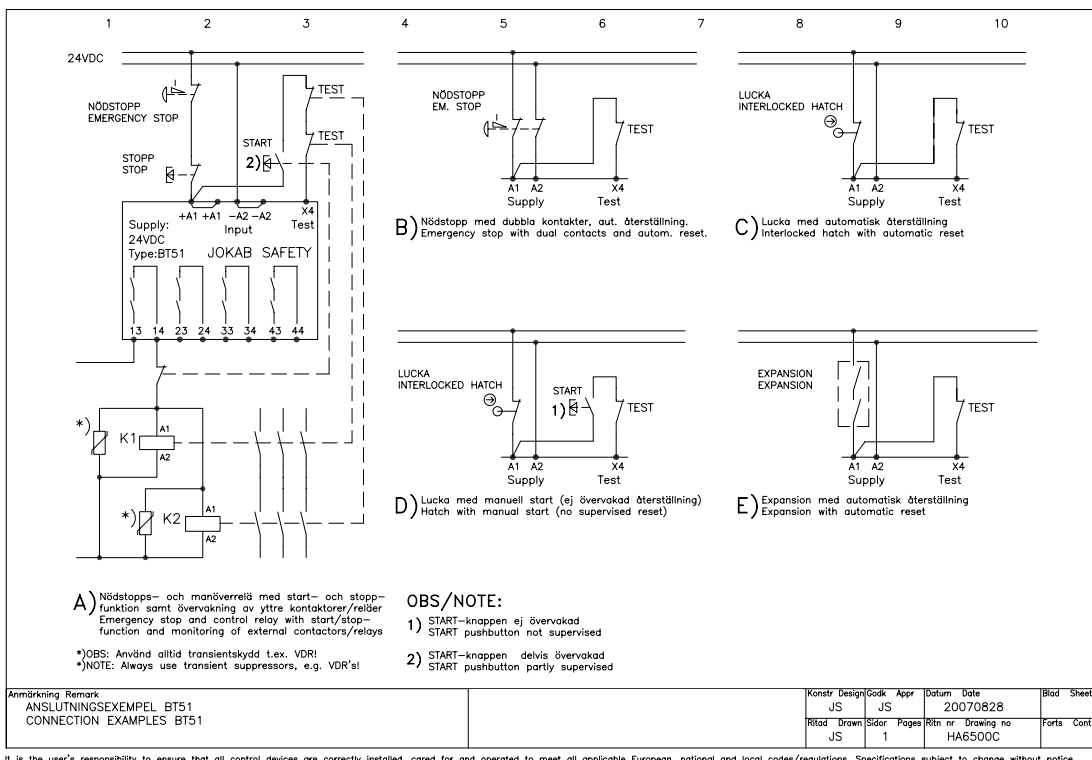

Connection examples

HA6501C Connection examples BT51T

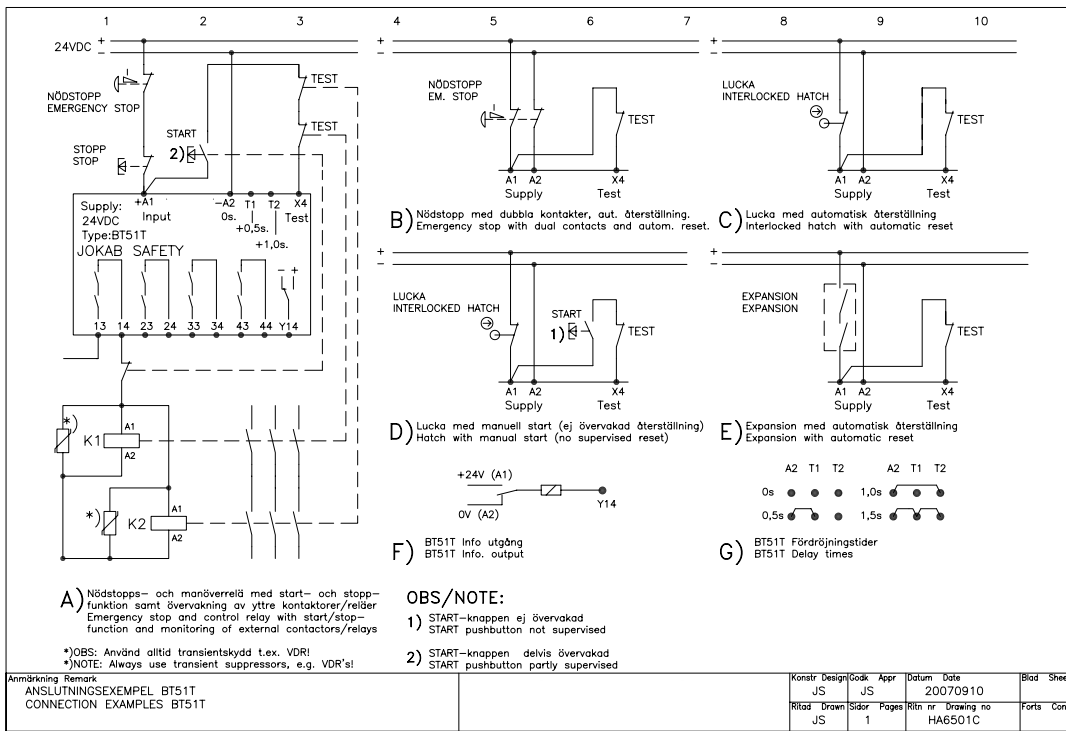

HA7100A Connection examples JSBRT11

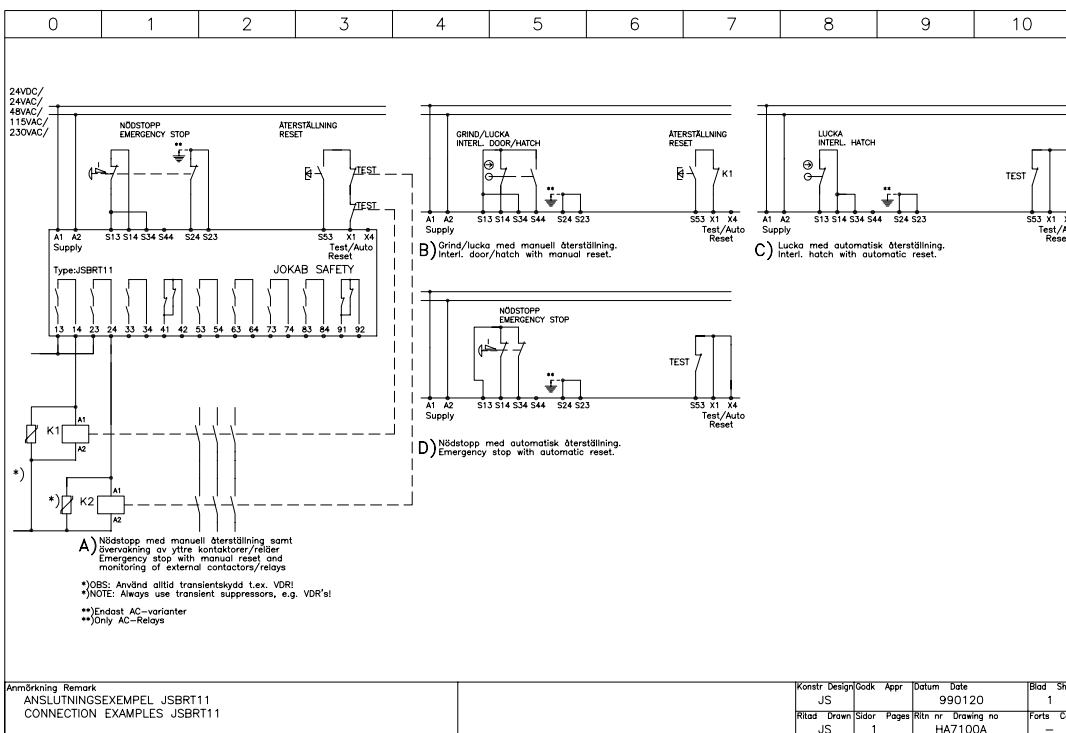

Connection examples

HA7600A Connection examples RT6

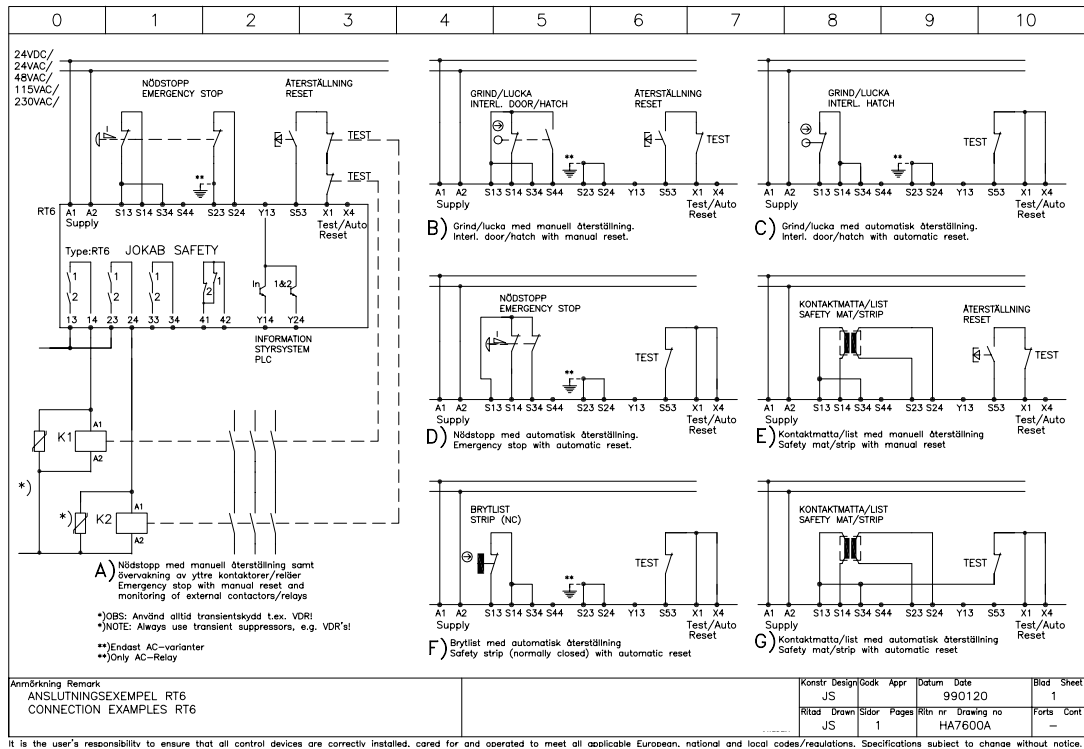

HA7600B Principle drawing RT6

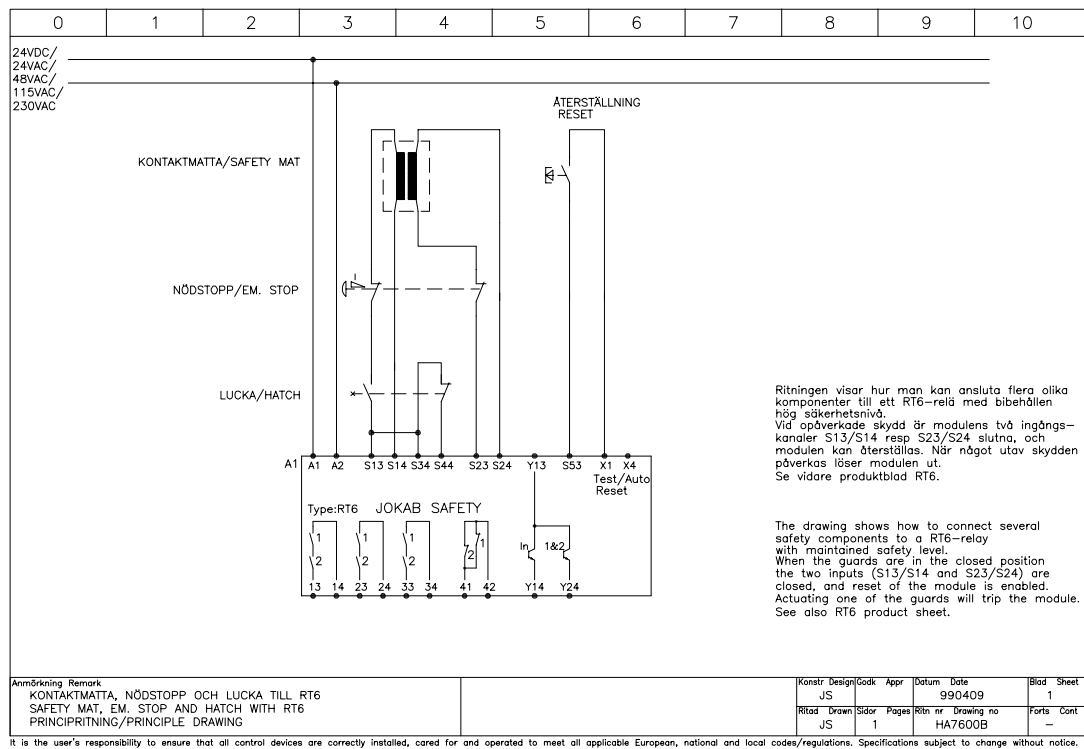

Connection examples

HA7672A Enabling device JSHD4 - EX with RT6

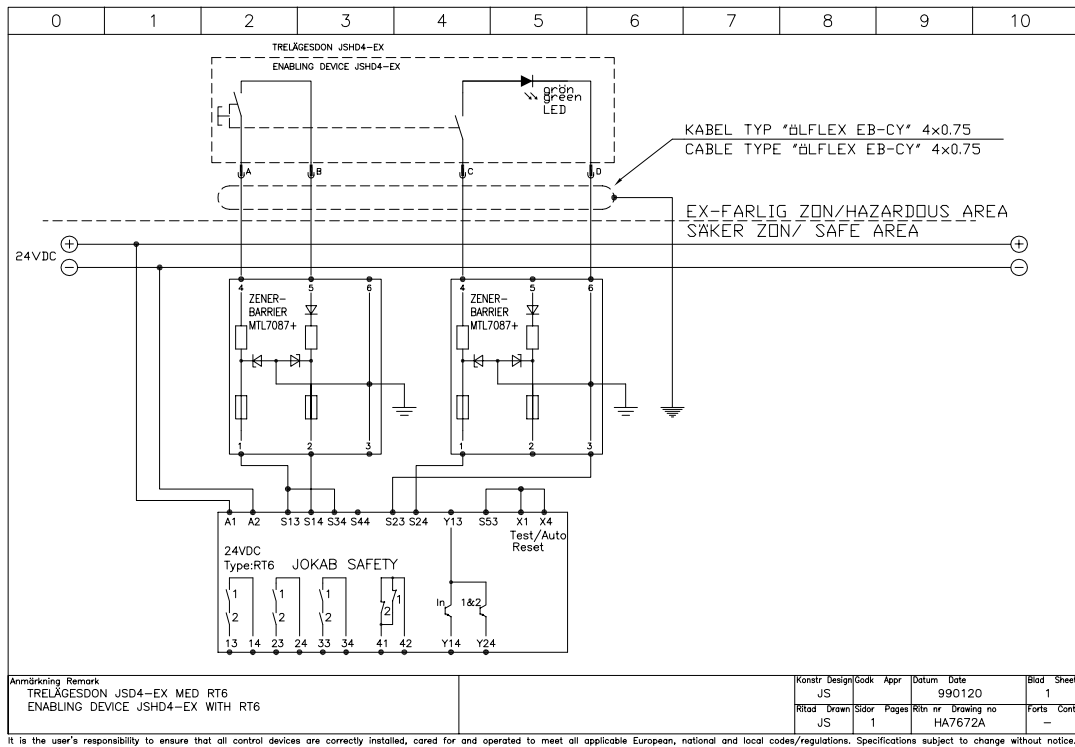

HA7700A Connection examples RT7

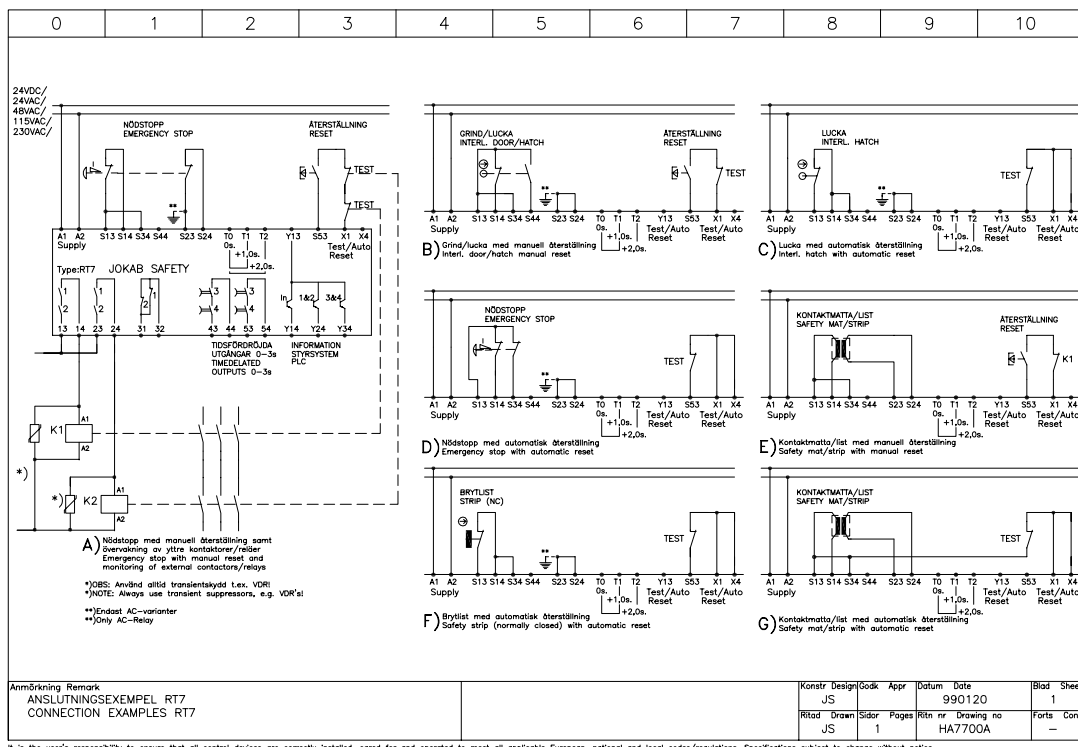

Connection examples

HA7900A Connection examples RT9

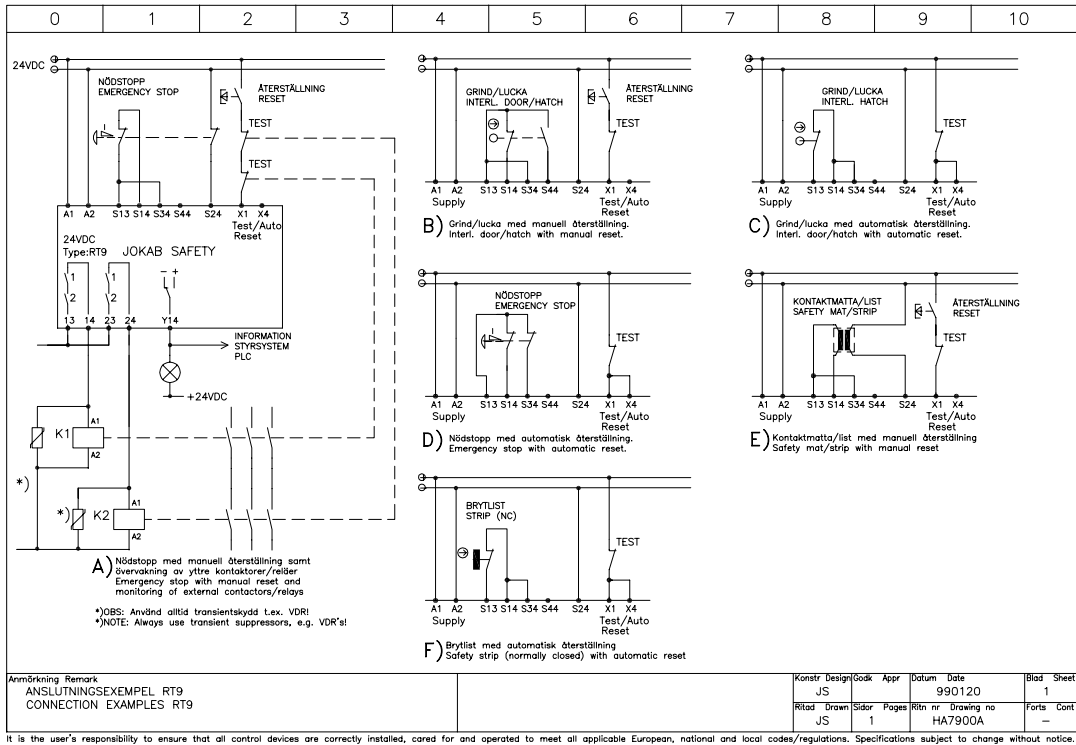

HE3811B Safety Light Beam Spot with time-limited reset

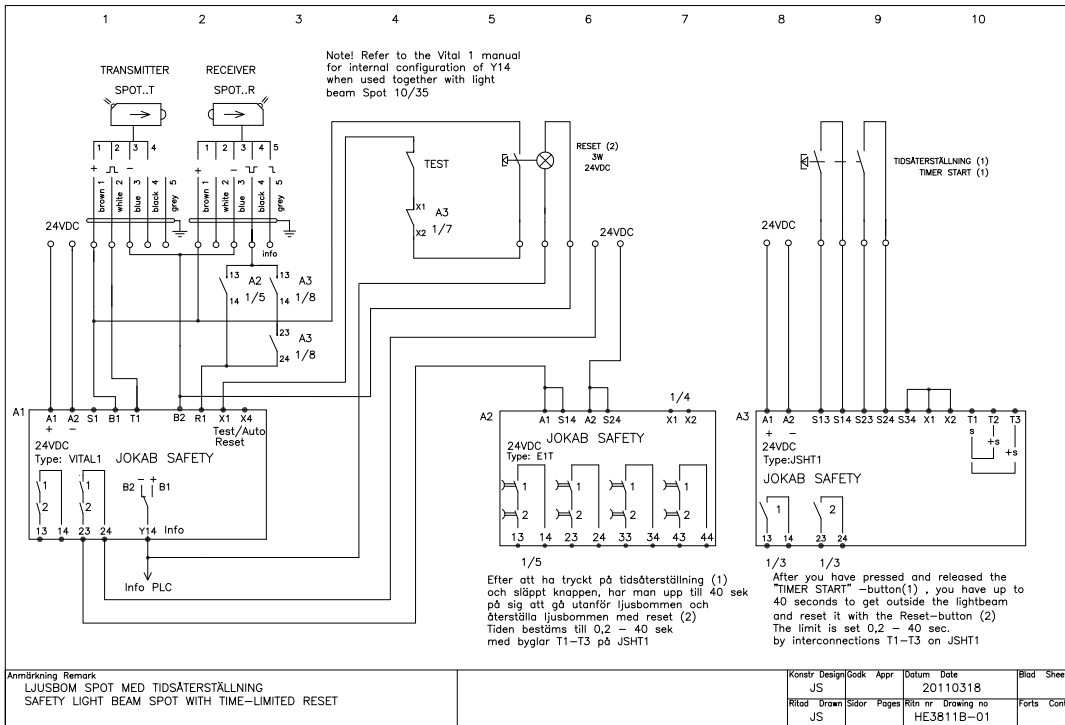

Connection examples

HE3824C-01 Lightbeam with time-limited muting 0.2–40 s

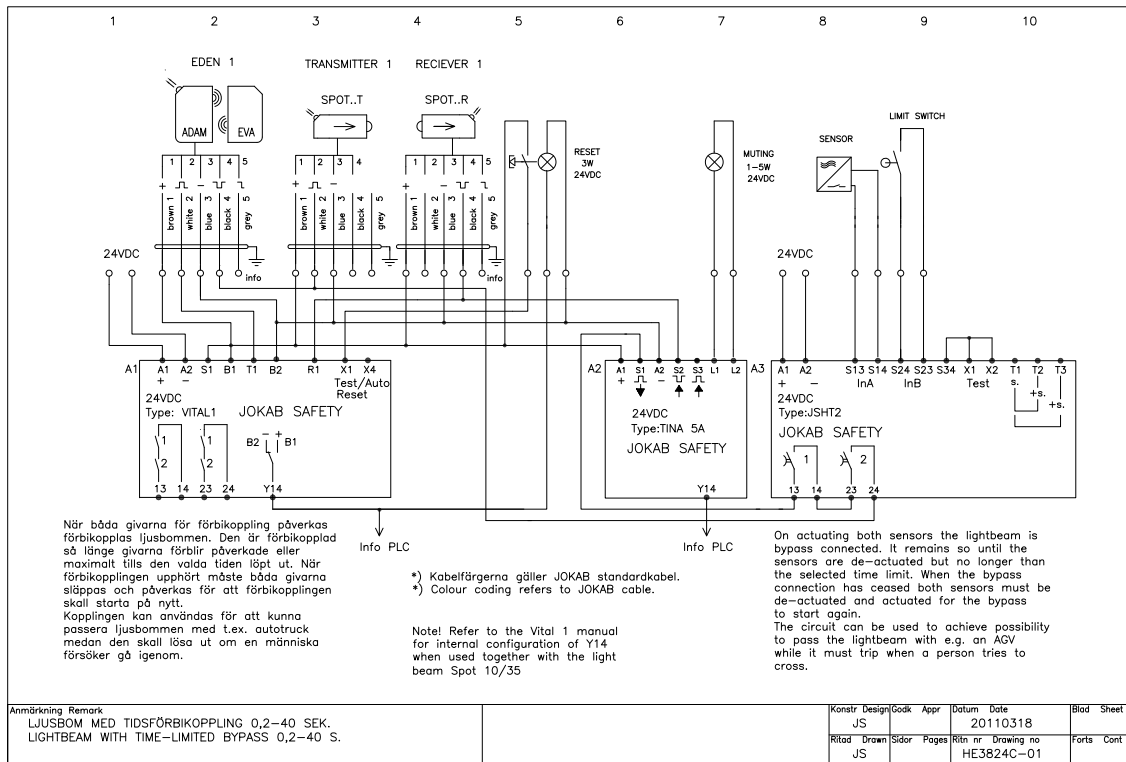

HE3824E-01 Lightbeams with time-limited muting 0.2–40 s

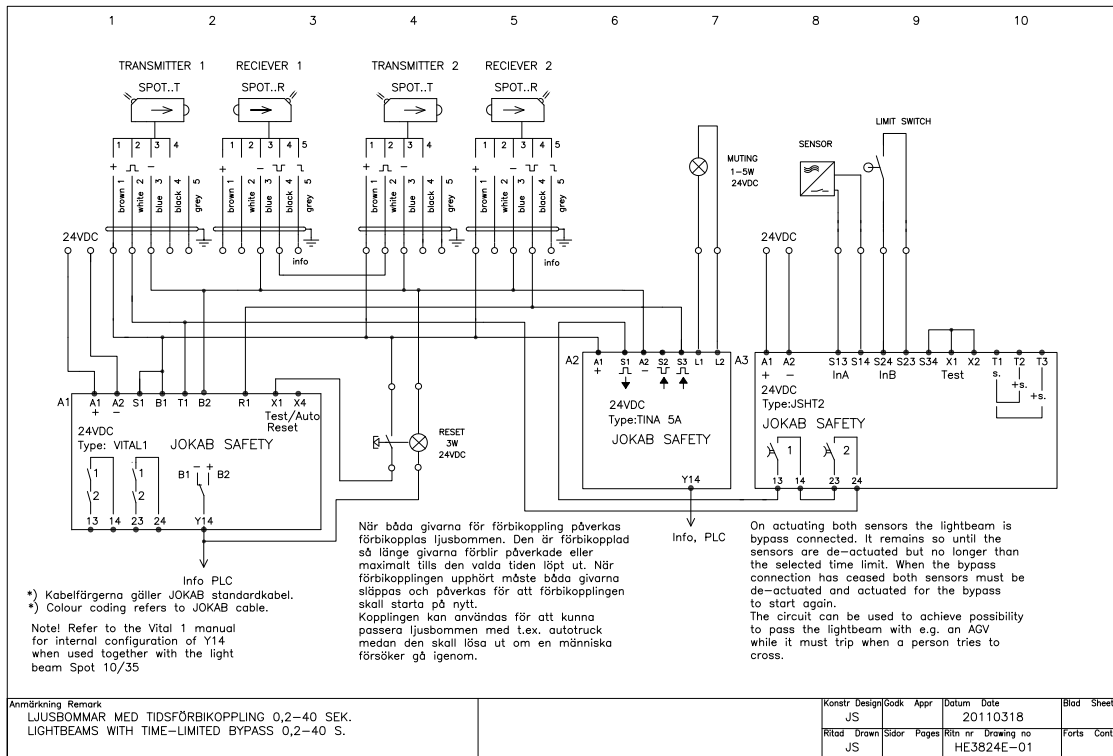

Connection examples

HG7636B Focus light grid/curtain with three-position device

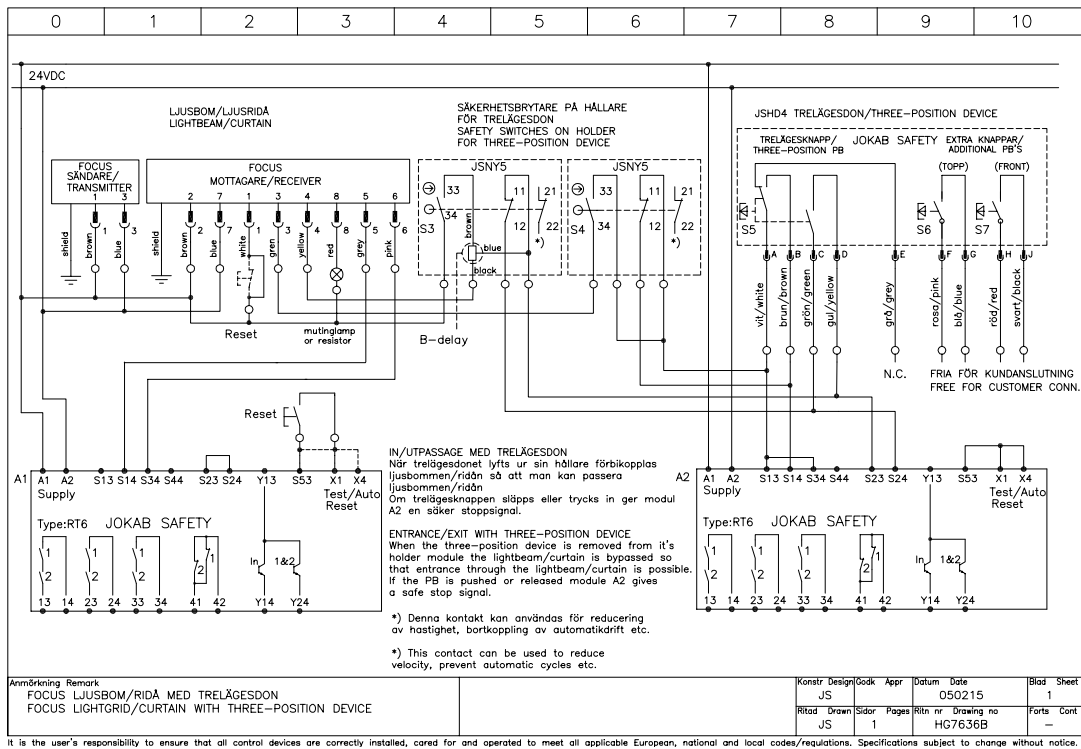

HG7611A Interlocked door with RT6 and pre-reset

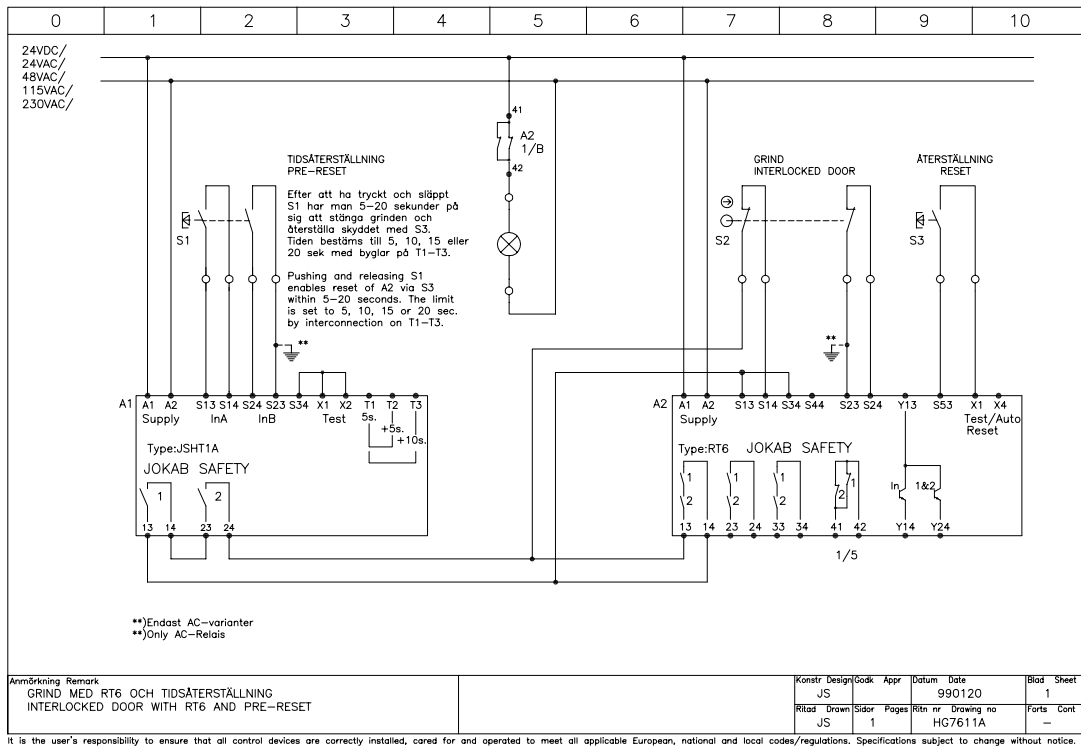

Connection examples

HG7636A Interlocked door with three-position device

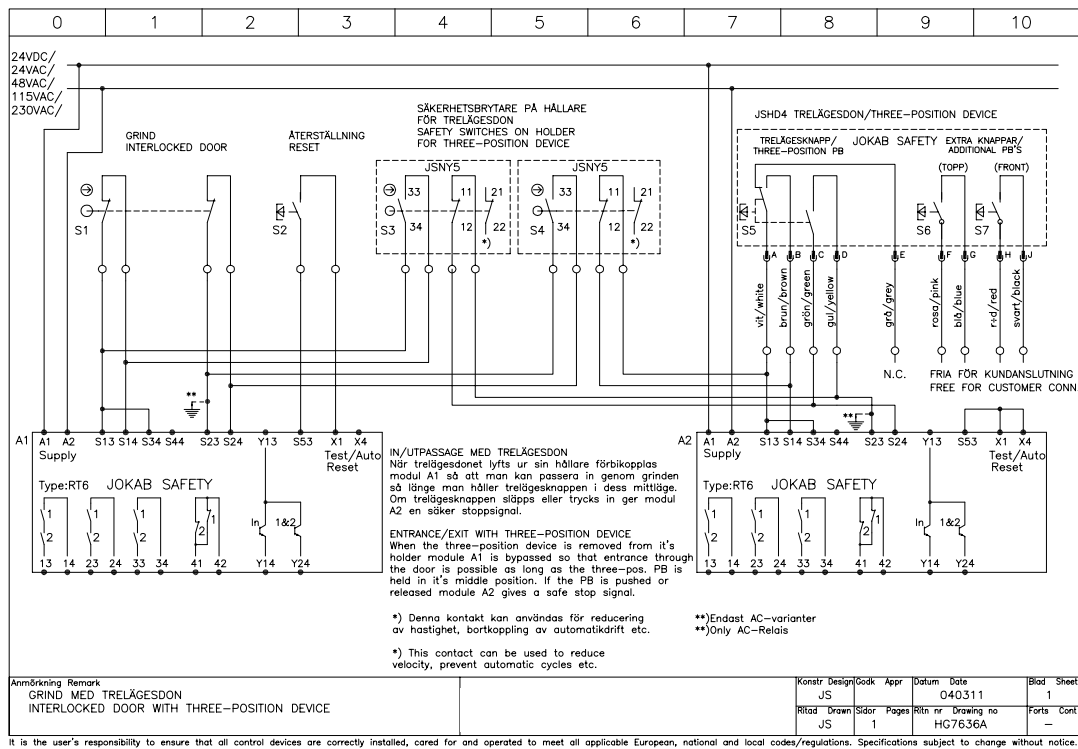

HG7646A Interlocked door with three-position device and time-limited entrance/exit

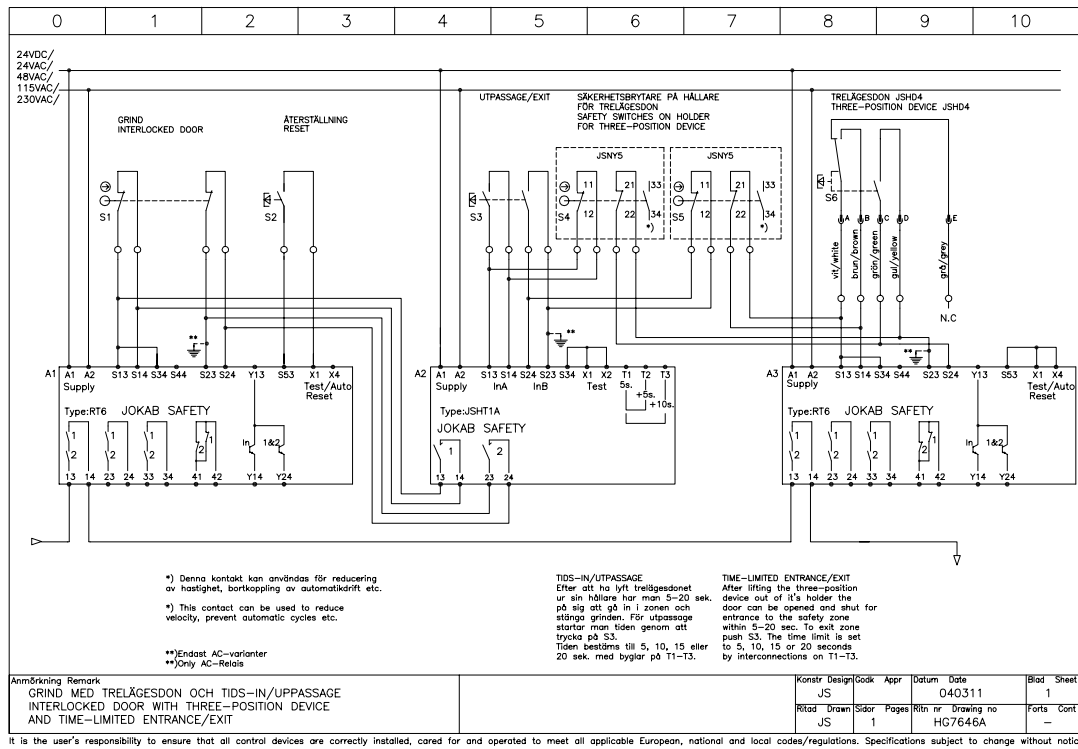

Connection examples

HG7654A Interlocked door with RT6 and output expansion JSR1T

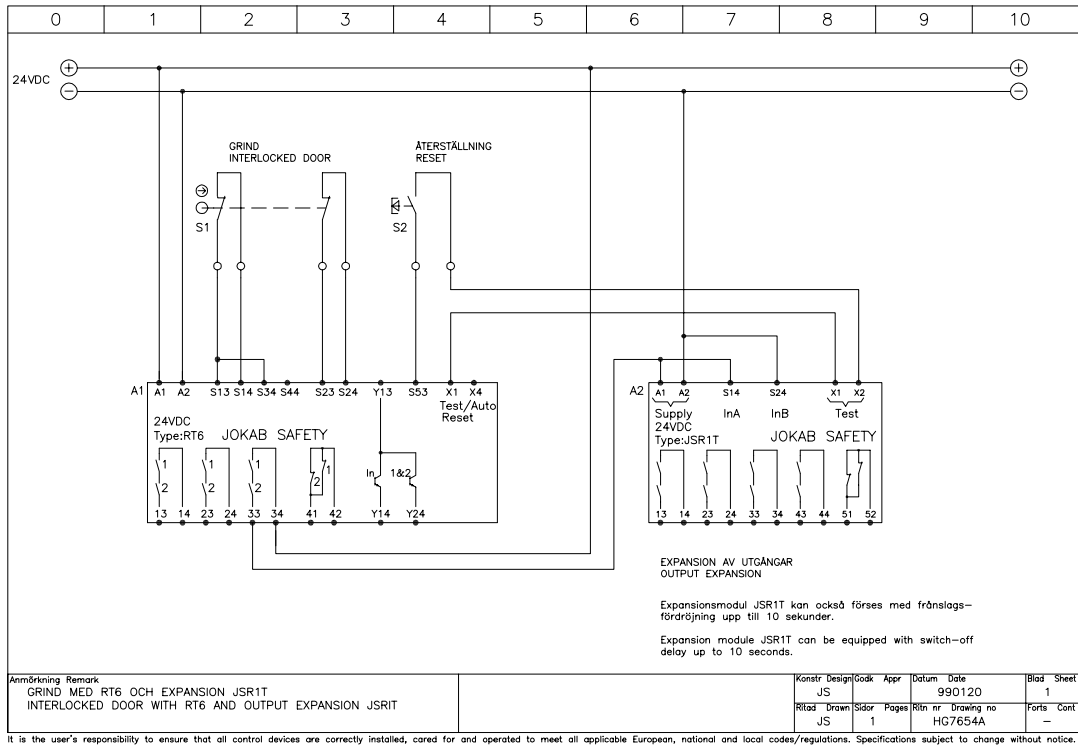

HG7658A Interlocked door with RT6 and output expansion JSR2A

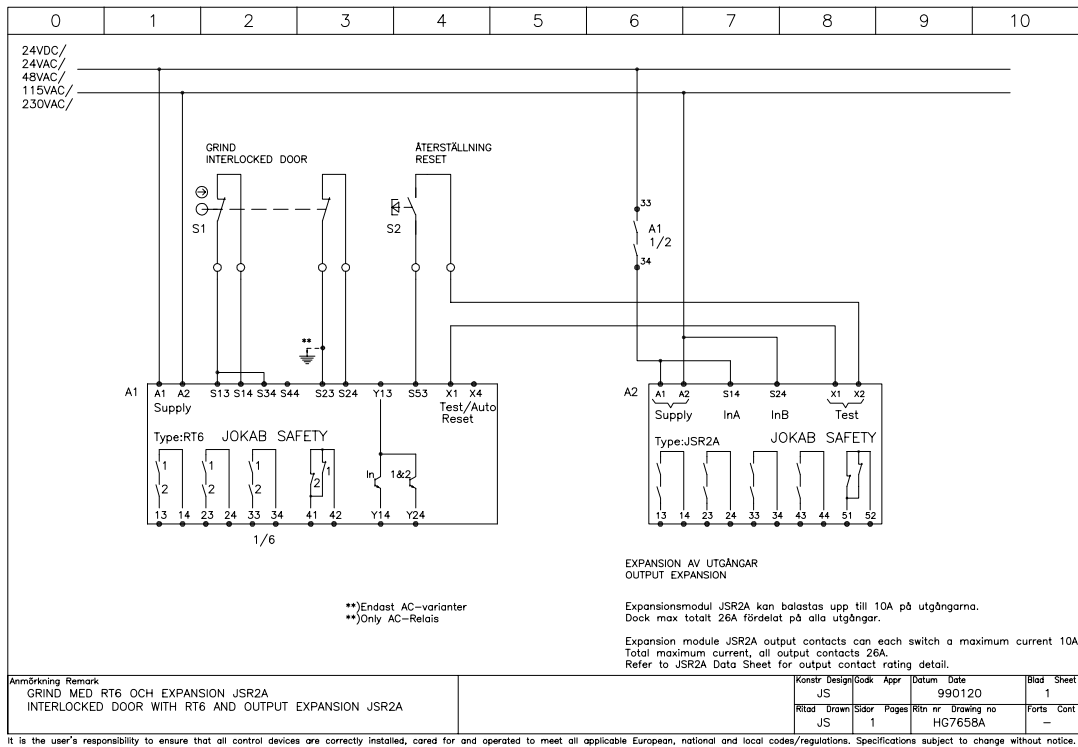

Connection examples

HG7673A Interlock switch JSNY8 with RT6

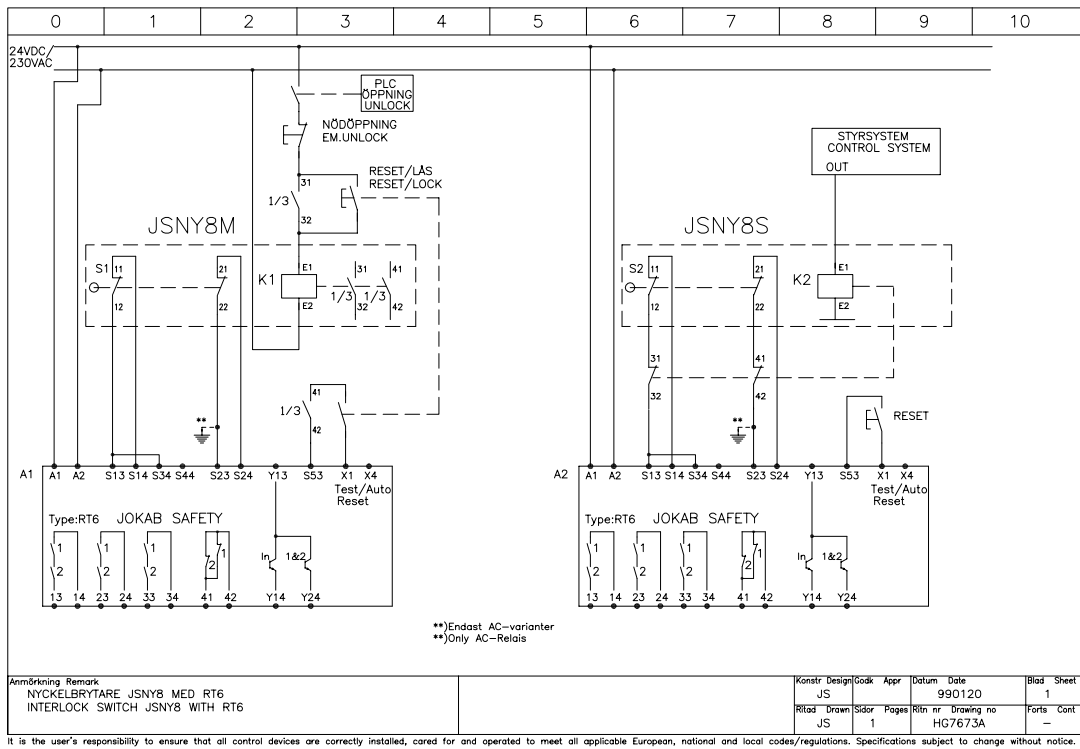

HG7674A Safety interlock switch JSNY9M/MLA with RT6

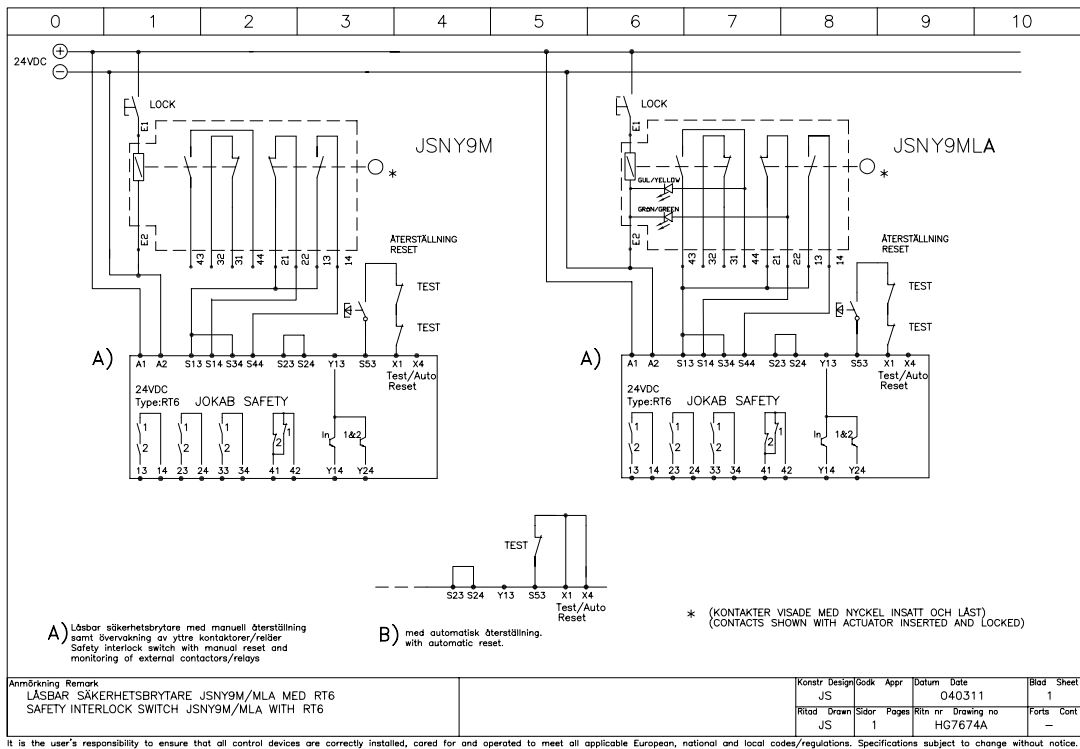

Connection examples

HG7674B Safety interlock switch JSNY9S/SLA with RT6

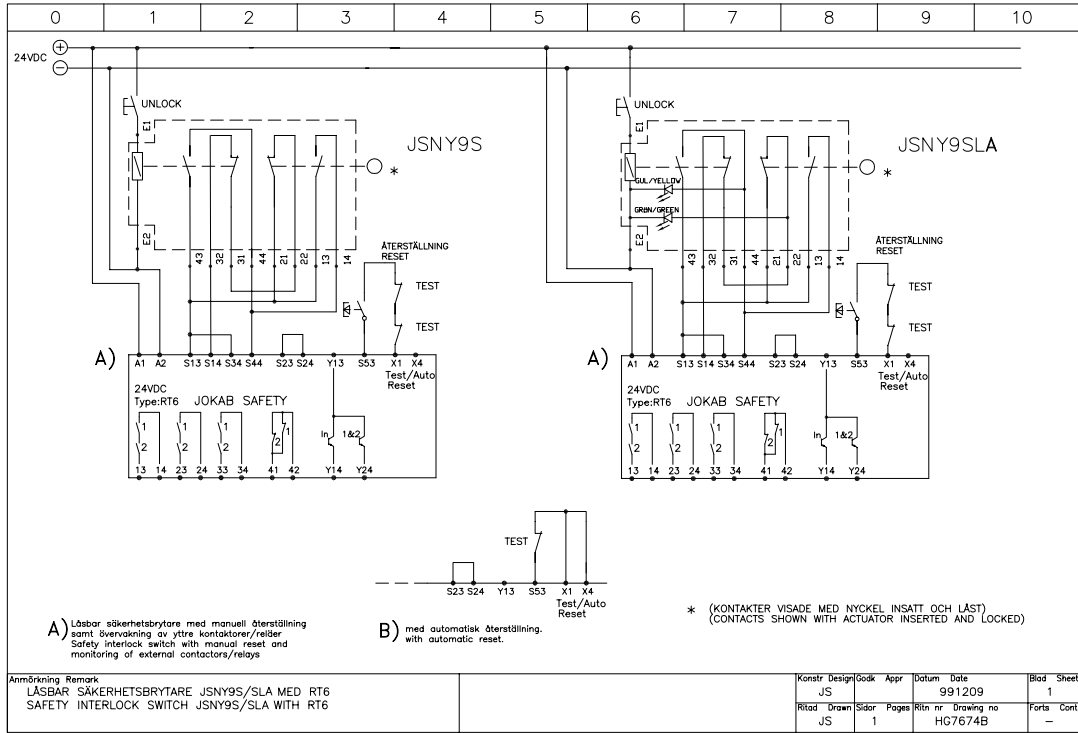

HH000C Three-position device JSHD4 with various safety controllers

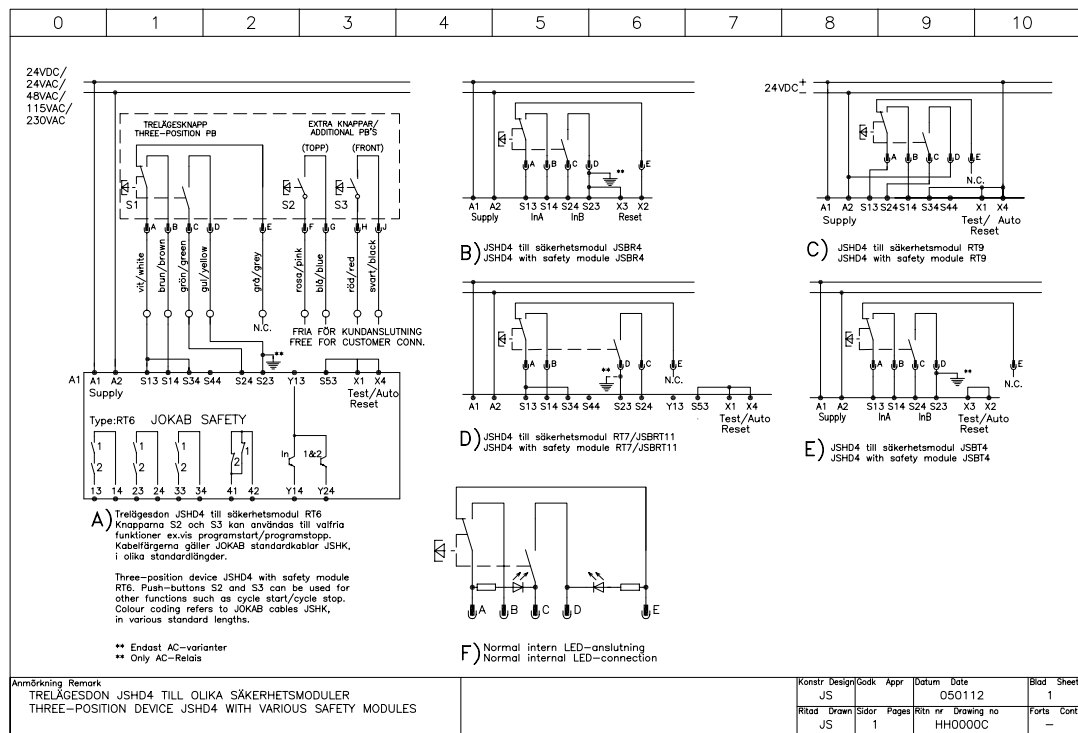

Connection examples

HI8552A Connection examples JSHT2 intermittent running

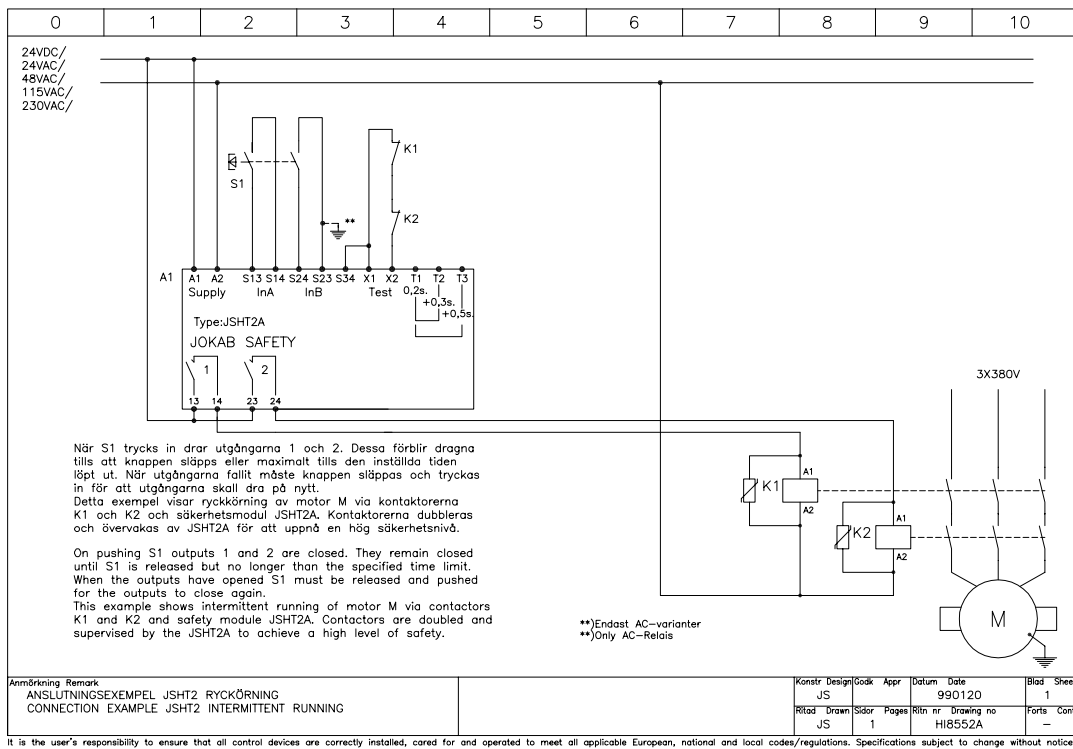

HK7600A Safety mat/Contact strip with RT6

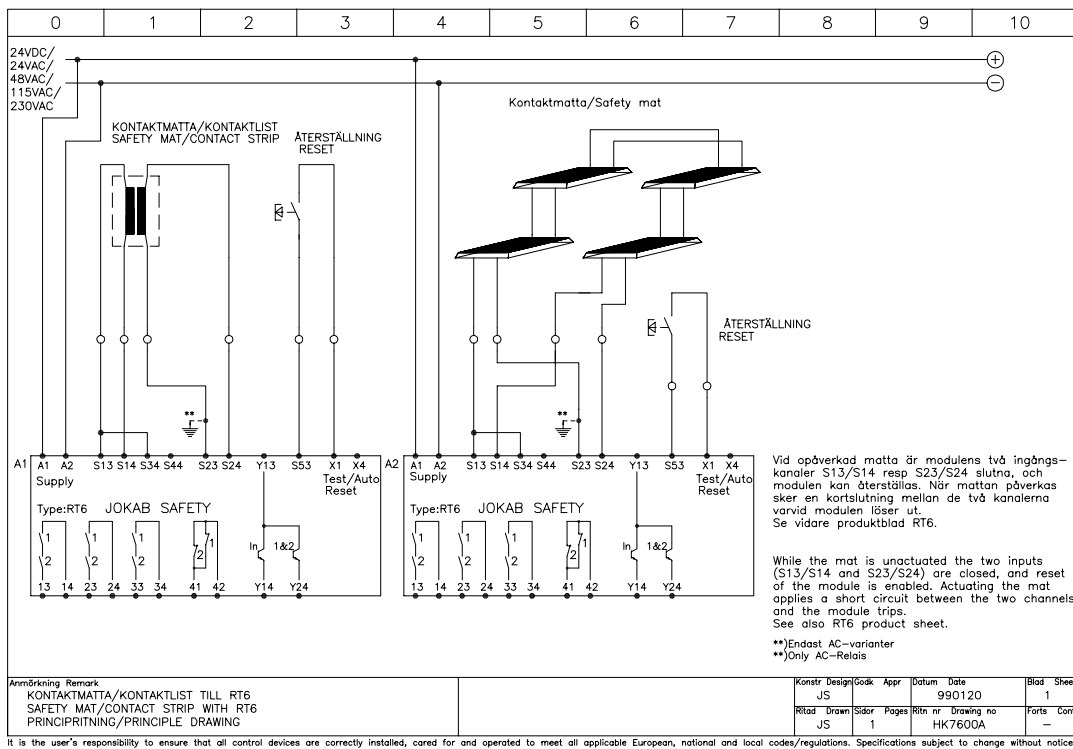

Connection examples

HL7600B Several JSNY7 connected to one RT6 with unique indication

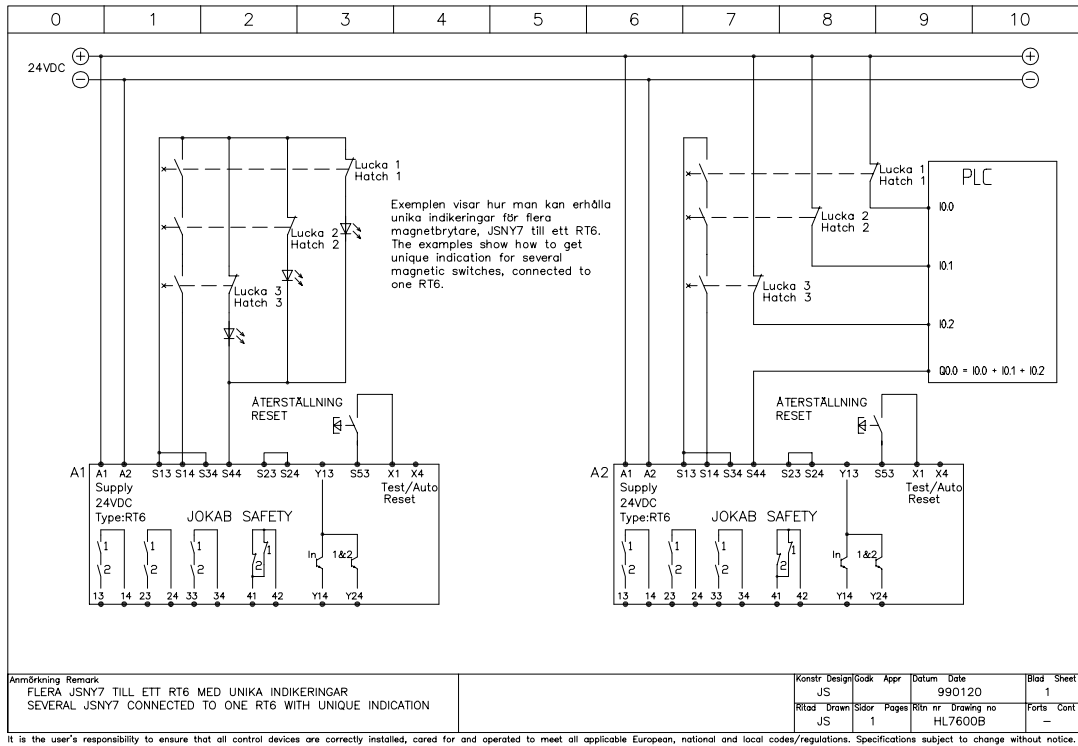

HM0000A Magnetic switch JSNY7 with various safety controllers

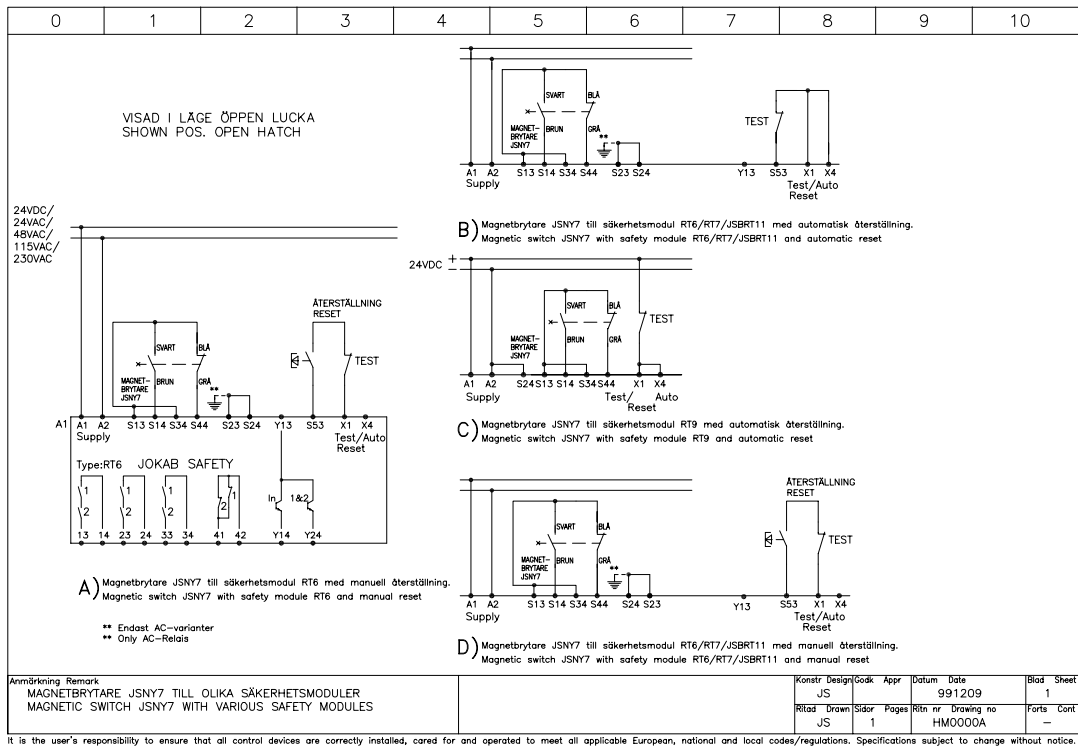

Connection examples

HN7660A Delayed outputs RT6 with output expansion JSR3T and RT7

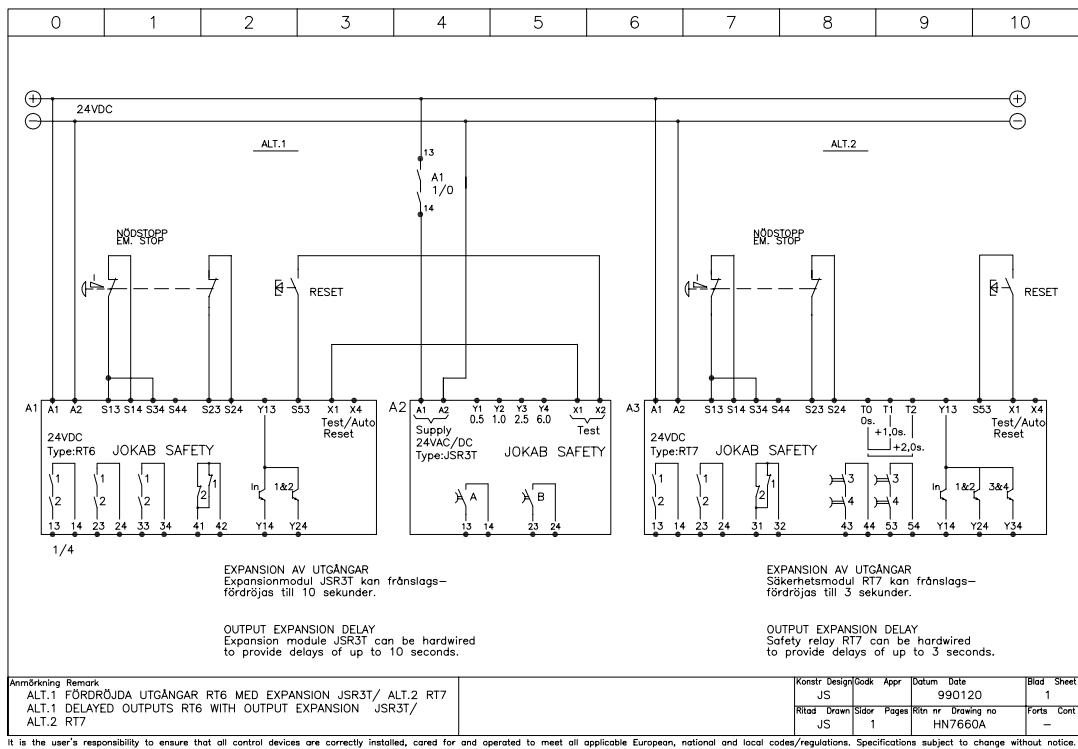

HP7600A Machine control - Isolation of PLC inputs and outputs

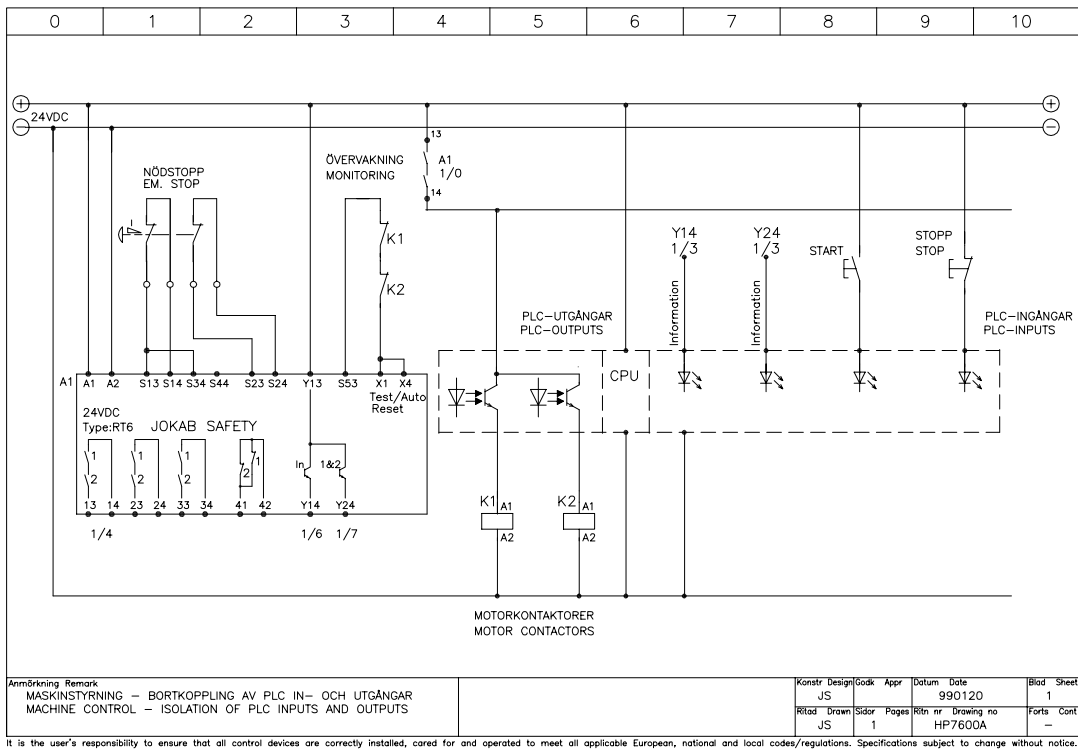

Connection examples

HP7600B Machine control-Isolation of PLC outputs

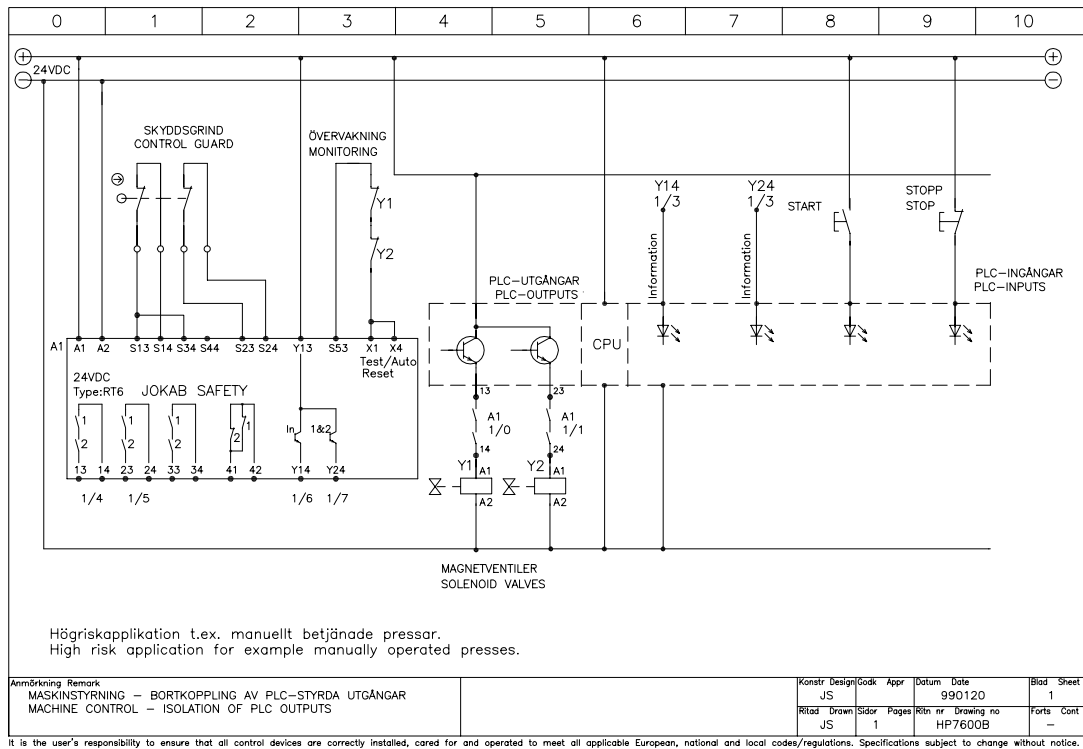

HR7200B Focus light curtain/beam

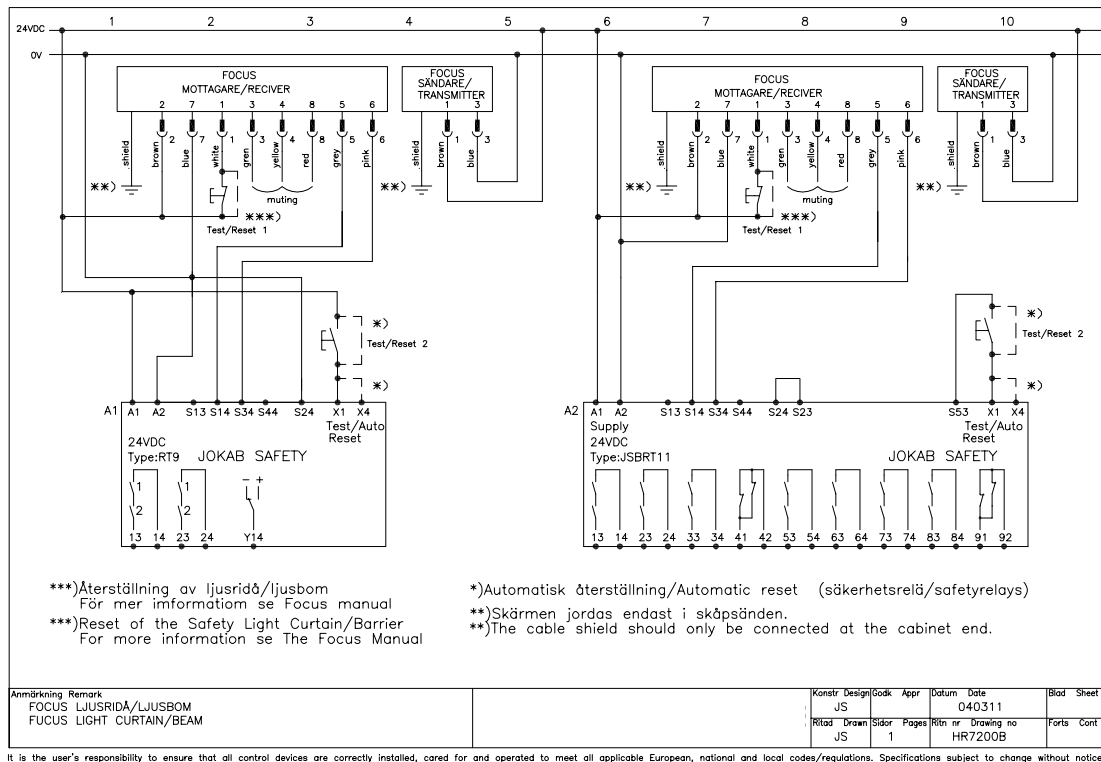

Connection examples

HR7800B Focus lightbeam/curtain

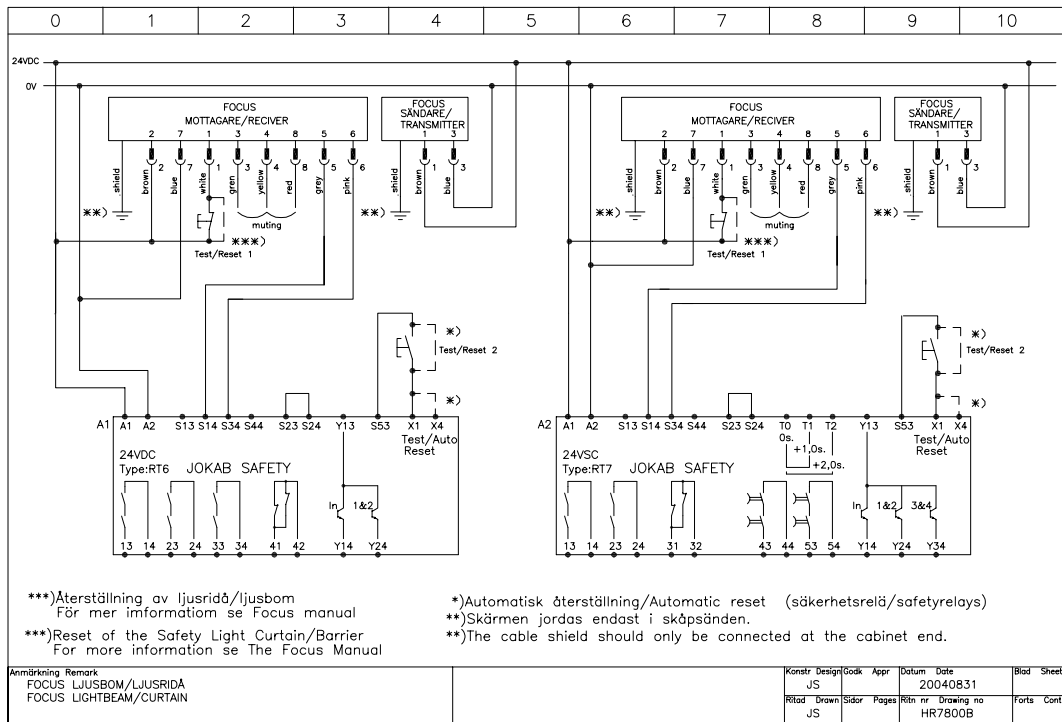

It is the user's responsibility to ensure that all control devices are correctly installed, cared for and operated to meet all applicable European, national and local codes/regulations. Specifications subject to change without notice.

HT5400A Two-hand device with safety relay JSBR4

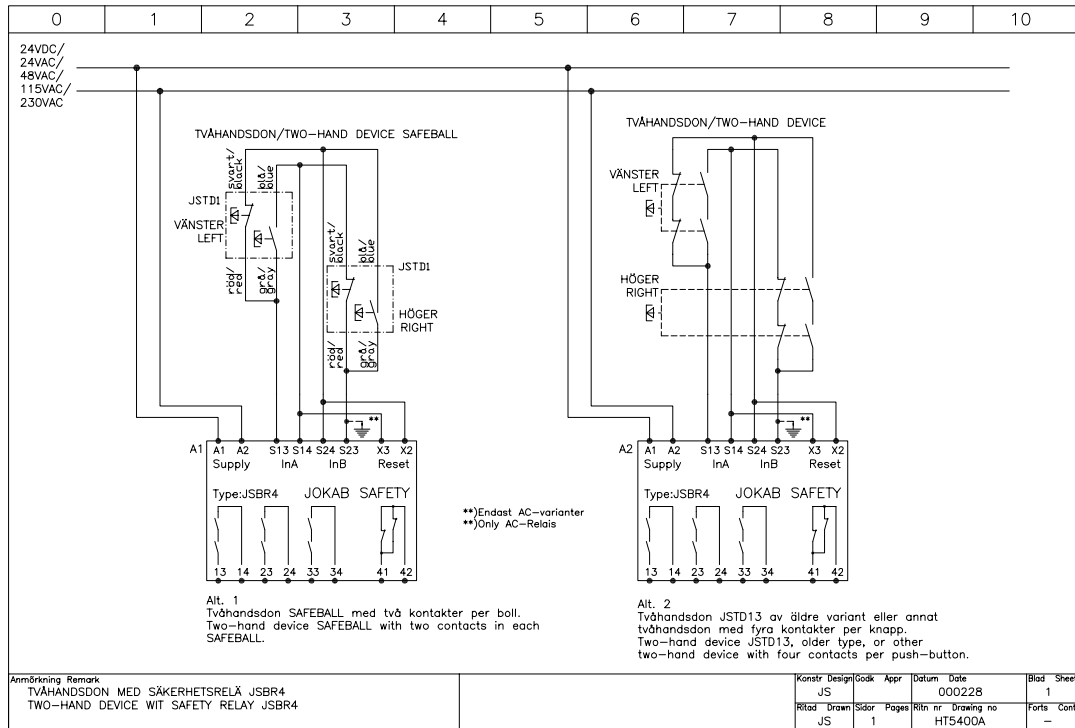

It is the user's responsibility to ensure that all control devices are correctly installed, cared for and operated to meet all applicable European, national and local codes/regulations. Specifications subject to change without notice.

Connection examples

HB0008A Focus light curtain/light beam connected to an RT9 with the aid of a M12-3D

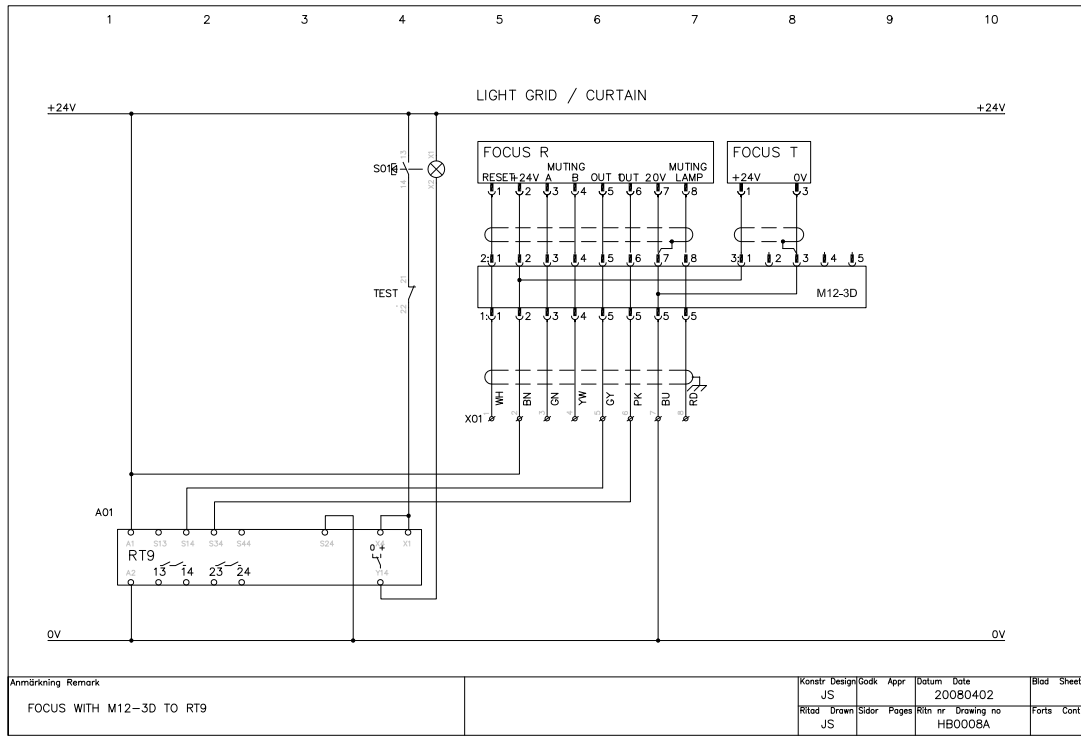



Light curtains, Light grids and Light beams

Why use light grids and light curtains?	7/3
Reset - 3 alternatives	7/5
Muting and blanking	7/6
Light curtain for short safety distance	7/7
Cycle initiation with light curtain	7/8
Safety distance	7/9

Light curtains, Light grids

Focus II	7/11
Muting units - MF-T, MF-L	7/16
Muting sensors - Mute R	7/18
Muting accessories - FMC, FMI	7/20
Accessories - MFII mirrors	7/22
Light protection stand - Bjorn	7/23
Protection against water and dust - WET	7/25
Blanking program - BP-1	7/26
Connection examples Focus II	7/27

Safety Light Beam

Spot	7/34
Connection examples	7/37

Why use light grids and light curtains?

Light grids and light curtains are production friendly safety components that causes no physical obstruction for the machine operator. Light barrier protection is also a good safety component to use when goods are to be passed in and out of a hazardous area.

How does a light grid/light curtain work?

Both light grids and light curtains utilise optical transmitter and receiver units. From the transmitters beams of infrared light are sent to the receiver. When a light beam is interrupted a dual stop signal is given to the dangerous machines inside the light grid/curtain protected area.

What is the difference between a light curtain and a light grid?

A light curtain has several beams that are placed closely together whereas a light grid consists of only one, two, three or four light beams. The beams are closest on a light curtain that is used for finger detection. Then the resolution is 14 mm. For light grids the beams are normally placed at a relative distance of 300 to 500 mm. The choice between light grid or light curtain is often a question of available safety distance, reach and price. Light curtains are often chosen for short safe/minimum distances. Light grids are chosen for longer safe/minimum distances, long range up to 40 m and for a low price.



Light grids for long distances

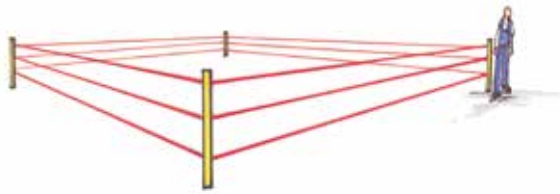

Light grids with monitored by-passing during material transport



Light curtain for short safe/minimum distances



Light curtain to protect during cycle initiation



Light curtain as area protection

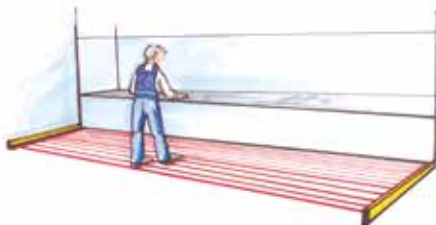

Light curtain for inner area limiting



What safety requirements are there for a light protection device?

High safety demands are stated in the standard EN 61496-1 which deals with light protection. The main demands are on a safe stopping function and that light from light sources other than the transmitter or other disturbances do not affect the safety function.

Depending on how the safety function is built up there are safety components of type 2 and 4 to choose between. Type 2 and 4 relates in principle category 2/PL c and category 4/PL e according to EN ISO 13849-1.

Type 4 which has the highest safety level, states that a fault is not allowed to affect the safety function and that the fault shall be detected by the outputs falling immediately or that they do not re-connect after being disconnected. Maximum allowed scattering angle for the light is $\pm 2.5^\circ$.

Type 2 states that a simple but monitored safety function is required, which means that the safety function shall be monitored through periodic tests which break the output when a fault occurs. Between the testing times there can though be faults which result in the safety component malfunctioning. The test function can either be built into the safety device or an external unit (e.g. the machine's control system) can initiate a test. Maximum allowed scattering angle for the light is $\pm 5^\circ$.

Light grids and light curtains are included among the products in the machine directive's appendix 4, which means that an external certifying procedure with an officially recognised institution is called for.

Reset – 3 alternatives

Supervised manual reset

When a light curtain/grid is interrupted it will give a stop signal to dangerous machines within the hazardous area it protects and a reset-lamp can be lit. For a new start of the machine the light curtain/grid has to be reset. This is done with the reset button which is placed where the whole hazardous area can be supervised and can not be reached from within the area which it protects.. There are high requirements on the reset function - neither a short circuit nor a component fault shall give automatic reset. When the reset button has been set the outputs are activated and the reset-lamp is turned off.

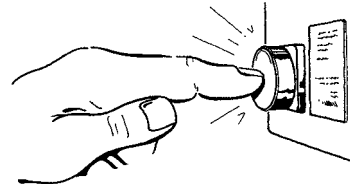

Reset button with light indication.

7 Supervised time-reset

When supervised time-reset (pre-reset) is in use, its purpose is not to allow a reset from outside the protected area without first having confirmed that no-one is out of sight within the area. To reset the light beam (see figure) button 1 must first be pressed and afterwards button 2 within e.g. 5 seconds. This is especially important when one cannot see the entire area that is protected by the light beam.

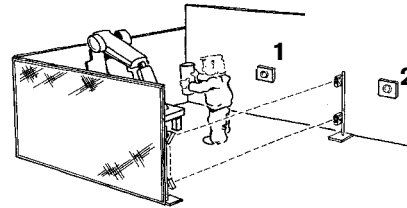

Button 1 is pressed and afterwards, within a chosen time e.g. 5 seconds, button 2 is pressed for resetting the light beam.

Automatic reset

Automatic reset is used when the light beam is used for area monitoring. When the light beam is actuated this indicates that e.g. a robot is in the area. The robot is stopped if a person enters the same area e.g. through a gate. When the light beam is free again the control unit will be reset automatically.

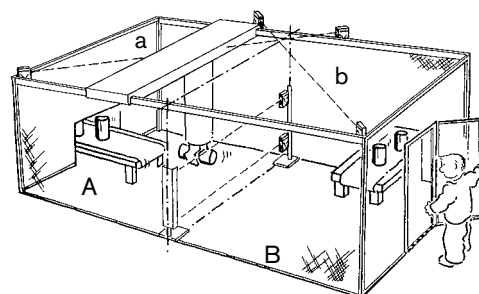

A light beam b indicates that the robot is situated in area A. In this position it is possible to walk in through the gate to area B without stopping the robot.

Muting (bypassing)

Bypassing may be needed for different reasons. One of the most common reasons for bypassing is during in and out feeding of material on a conveyor, Automated guided vehicle (AGV), etc. Another common application is bypassing while passing with a three-position device to the hazardous area.

Important aspects for bypassing is that it shall be safe, not be activated by mistake and be difficult to defeat. In other words it shall give a reliable bypassing when a loading carrier enters but not allow a human to pass. To achieve the highest safety level a dual and supervised bypassing system is needed (usually with at least two independent signals). If this is done with sensors, it is recommended they be of different kinds, because of the probability of them both malfunctioning for the same reason e.g. common cause failure. An example of a solution is to use a mechanical limit switch and a photo-cell sensor.

To avoid deliberate defeating/manipulation of the bypassing sensors/signals a safety relay or a safety-PLC is connected thereby monitoring that the sensors are both activated and deactivated in every bypassing cycle.

The number of variations in bypassing systems are almost infinite. This depends on the specific requirements of each plant/machine. For Focus II there are a number of bypassing possibilities prepared.

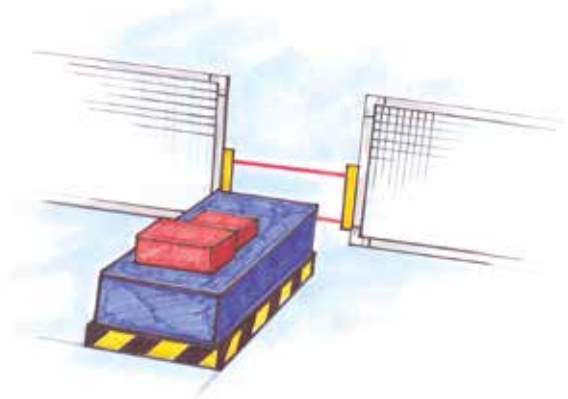

Automatic bypassing of light grid when an Automated guided vehicle passes.

Blanking

Blanking means permanent switching off of a number of beams in the detection zone of a light curtain. This is a function that is permitted and used when an object that is larger than the resolution of the light curtain is permanently located in the detection zone, without deactivating the safety outputs (OSSD). If the object is removed from the detection zone, the safety outputs are deactivated.

Blanking function has different tolerance settings that allow movement or vibration of the objects that obscure the detection zone.

One tolerance setting can be called "Floating blanking", that means that the part of the zone which is intentionally blocked can be moved around in the detection zone while the machinery is operating. Other beams are active and providing normal protection, but often with reduced resolution.

When a "blanking" function is used, it is very important that the light curtain provides protection and can detect objects, as small as a finger or hand, depending on the resolution, anywhere outside the zone that is rendered inactive because the object is there. Blanking may require an additional fixed guard and may require additional minimum distance to the dangerous movement.

It must not be possible to select the "blanking function" without using a key, tool or similar unlocking device.

Light curtain for short safety distance

A light curtain can be used in a machine or a production plant in the same way as a hatch. There is a great difference though when it comes to the risk situation. When one has a light curtain installed with a short minimum distance in front of a dangerous machine, there is a high risk for spontaneous engagement into the machine, often called after-grasp. If the dangerous machine movement does not stop during such an engagement, one has a small chance of avoiding injury.

Therefore it is of great importance that the whole chain in the stopping circuit is dual and supervised. Even valves and contactors which ultimately control dangerous movements normally have to be doubled up and supervised.

Regulations concerning safety distances are given in specific C-standards such as EN 692 for mechanical presses. If no specific C-standard is available, EN ISO 13855 is used.

Automatic machines

7

For light curtains on automatic machines there shall be a reset function which is active when the machine is set for automatic production whether or not it is a passable protection. After affected a light curtain, one must first use a reset function then the restart of the cycle shall be made with a separate starting device. The same reset applies for machines with semi-automatic drive.

Operator protection during manually serviced machines

Manually operated machines where one or more operators pick in and out parts between every cycle are the most risky light curtain applications. This because of the number of engagements into the machine's hazardous area is often several times per minute.

Light curtains on presses

Light curtains have traditionally been a common protection method among press applications and there has since long existed detailed information on the usage of light curtains on presses. (see next spread for "Cycle initiation with light curtain"). Only light curtains of type 4 are accepted on presses.

Reset

On the servicing side i.e. the side or sides where there is an operator that picks in and out parts, there shall be a separate reset function for the light curtain, usually a button. If there are several light curtains e.g. on the front and back there shall be one for each. If the light curtain is actuated during a dangerous movement the press shall not be able to restart without being reset. During engagement after the end of the cycle no reset is needed.



Hand resolution



Finger resolution

Cycle initiation with light curtain

Cycle initiation

Cycle initiation is a concept when the machine is designed so that a new cycle initiated by affecting the light curtain. A cycle is defined as the hand being placed in and taken out once. Usually it is possible to choose between one-cycle and two-cycle operation. During one-cycle a new action is started when the light curtain has been actuated once and during two-cycle when the light curtain has been actuated twice. The operator thereby operates the machine by the action of putting parts in and out.

On presses this "Cycle initiation" function is very common. But because the press starts without any particular command there are some risks involved and therefore many conditions have to be met before the machine operates.

Smaller presses which cannot be entered have certain regulations that means some limitations: The table height may not be lower than 750 mm, the stroking length may not be larger than 600 mm and the table depth may not be larger than 1000 mm. The light curtain shall have 30 mm or higher resolution. If the press is not started within approx. 30 seconds after the end of the cycle, a new cycle shall not be accepted without the light curtain being again manually reset. **NB.** For machines with cycle initiation, the installation of the light curtain must be in accordance with machine parameters and all relevant standards and regulations.

Installation of light curtain

The light curtain must be installed so no-one can reach a trapping/crushing risk without actuating the light curtain. The most important thing is that there are no gaps under, on the sides and over the top during cycle operation. The lower edge of the light curtain must therefore be slightly below the

Installation – correct and incorrect during cycle initiation



Correctly installed.

The operator cannot reach into the machine without actuating the light curtain.



Incorrect installation.

Gap below the light curtain. The operator can reach into the machine without actuating the light curtain.



Incorrect installation.

Gap above the light curtain. The operator can reach into the machine without actuating the light curtain.



Correctly installed.

Light curtain complemented with a horizontal light curtain to detect the operator.

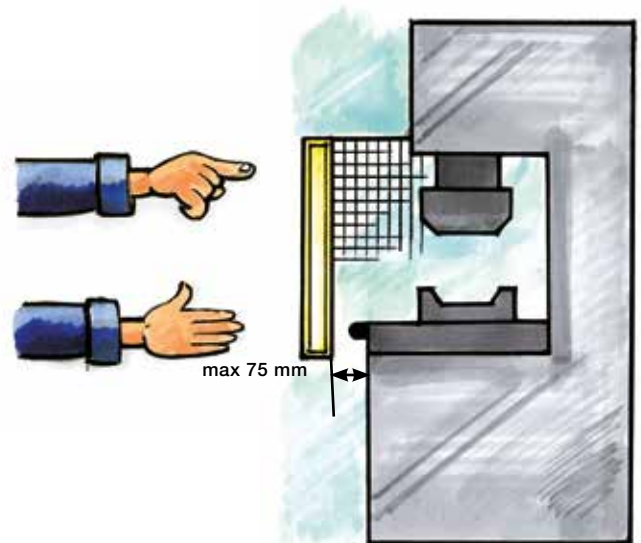

press table edge. Also if it is open above the light curtain the height must be adapted so that it is not possible to reach over the detection zone (see ISO 13855). Physical adjustment possibilities must be limited so that dangerous motions are placed out of reach.

Between the light curtains detection zone and mechanical parts there shall only be max 75 mm gap to prevent a person from standing there. In practise to achieve this demand and the required safety distance one usually has to complement with e.g. additional mechanical protection or additional horizontally positioned light curtains i.e. step-in light curtain. Another solution could be a lying or an angled light curtain.

Minimum distance for light protection according to EN ISO 13855

The distance 'S' is a minimum distance between a light curtain and a hazardous area. The distance shall prevent that a person is not able to reach a hazardous machine part before the machine movement has stopped. This is calculated with the formula from EN ISO 13855 - Safety of machinery - Positioning of safeguards with respect to the approach speeds of parts of the human body.

$$S = (K \times T) + C$$

S = minimum distance in mm

K = body/part of body (e.g. hand) speed in mm/s

T = T1 + T2

where

T1 = the safety device's reaction time in seconds

T2 = the machine's reaction time in seconds

C = additional distance in mm based upon the body's intrusion towards the hazardous area before the safety device has been actuated.



Resolution for finger (≤ 14 mm) gives C = 0

NB If it is possible to reach the hazard zone by reaching over the light beam, an addition is made to the formula. In table 1 in EN ISO 13855 an alternative safety distance addition (C_{ro}) is given to the formula $S = (K \times T) + C$. The greatest value out of C and C_{ro} is to be used to prevent reaching the hazard zone by reaching over the light curtain/grid.

Minimum distances for vertical and horizontal installed light curtains according to EN ISO 13855

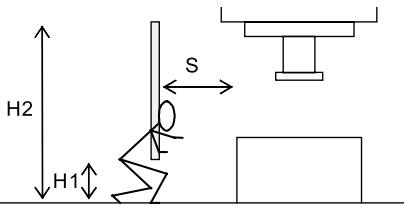

S = minimum distance in mm

H1 = the lower beam may not be situated higher than 300 mm above the ground

H2 = the upper beam may not be situated lower than 900 mm above the ground

For $S \leq 500$ mm the minimum distance for vertical installation is calculated with the following formula:

$$S = (2000 \times T) + 8 \times (d - 14)$$

where d is the light curtain's resolution in mm.

K here is 2000 mm/s which represents the speed of the hand. The expression $(8 \times (d - 14))$ may never be less than 0. Minimum distance S is 100 mm.

If the minimum distance according to the formula above gets larger than 500 mm one can instead use:

$$S = (1600 \times T) + 8 \times (d - 14)$$

K is 1600 mm/s which represents the speed of the body. Minimum distance according to this formula is 500 mm.

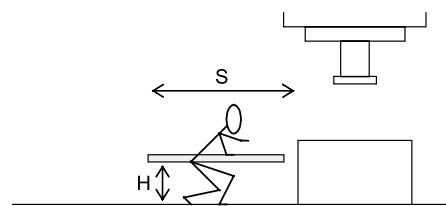

S = minimum distance in mm

H = the light curtain detection zone must be positioned between 0 and 1000 mm above the floor

The minimum distance for horizontal installation is calculated with the following formula:

$$S = (1600 \times T) + (1200 - 0.4 \times H)$$

where H is the height of the detection zone above the reference plane, e.g. the ground

$(1200 - 0,4 \times H)$ may not be less than 850 mm. Depending on the resolution, d, that the light curtain has, there is a minimum height that the detection zone may be placed. This is calculated with:

$$H = 15 \times (d - 50).$$

H cannot be less than 0. With a resolution $d = 14$ or 30 mm one can therefore install the light curtain from $H = 0$ and up. The higher it is situated, the shorter the minimum distance gets. The highest permissible height H of the detection zone is 1000 mm.

When you use a horizontal light curtain as entry protection, the depth of the light curtain shall be at least 750 mm to prevent people from inadvertently stepping over it. The estimated minimum distance is measured from the machine's hazardous section to the outermost beam of the horizontal light curtain (seen from the machine).

Minimum distance for light beams according to EN ISO 13855

For light beams the minimum distance is calculated from the following:

$$S = (1600 \times T) + 850 \text{ mm}$$

NOTE! The additional distance will in most cases be more than 850 mm due to the possibility to reach over a light beam. (C_{ro})

The formula applies whether one installs 2,3 or 4 beams. It is the risk assessment that decides the number of beams that are to be chosen. The following possibilities must be considered.

- to crawl under the lowest beam;
- to reach over the top beam;
- to reach in between two beams;
- that the body passes in between two beams.

To fulfill the requirements the beams shall be installed at the following heights:

Number of beams	Height over the reference plane, e.g. ground
4	300, 600, 900, 1200
3	300, 700, 1100
2	400, 900

Minimum distances for new and old presses

New presses

For new CE-marked presses there are specific requirements from the standards EN 692 Machine tools – Safety – Mechanical presses – Safety and EN 693 Machine tools – Safety – Hydraulic presses.

The same requirements apply for vertical installation on presses as with vertical installation on other machines with the difference that C is given according to the following:

Resolution, d, (mm)	Minimum distance addition, C (mm)	Cycle initiation
≤ 14	0	Permitted
>14 - 20	80	
>20 - 30	130	
>30 - 40	240	Not permitted
>40	850	

Other manually serviced machines

The rules for presses may well be applied to other machines which function in a similar way and that have the same risk situation. There is no other standard which is as detailed on the usage of light curtains.

For cycle initiation the light curtains resolution, d, must be ≤ 30 mm. This applies to both old and new (CE-marked) presses.

Old presses

“NB” For old presses there are different rules for each country.

The formula that applies here is:

$$S = (2500 \times T) + C$$

The minimum distance addition C for different resolutions of the light curtain is given in the following table

Resolution, d, (mm)	Minimum distance addition, C (mm)
<16	0
16	70
20	110
25	130
30	140
35	240
40	270
45	300
50	330
55	360
>55	850

Safety Light Grids and Safety Light Curtains Focus II

Approvals:



Application:

- Optical protection in an opening or around a hazardous area

Features:

- Type 4 according to EN 61496
- Flexible assembly
- LED indication
- High protection class (IP65)
- Range 0.2-40 m
- Time reset
- Fixed / floating blanking
- Muting
- Single/Double Break funktion
- External Device Monitoring (EDM)
- Available with different resolutions
- Up to PL e according to EN ISO 13849-1



7

A light grid/light curtain with many possibilities

Focus II is a new version of our previous light grid/light curtain Focus. Features such as muting and override are standard in all Focus II light curtains and light grids. For light curtains, blanking and break functions are also standard. The optical sensors on Focus II also have variable coding. The Focus II units are light grids/curtains with safety functions intended for applications where it is of great importance to protect persons from a dangerous machine, robot or other automated systems where it is possible to access to a hazardous area.

Focus II creates a detection zone with infrared beams. If any beam is interrupted the safety mechanism is triggered and the dangerous machine is stopped. Focus II fulfills the requirements for non-contact safety equipment type 4 according to the international regulation standard EN 61496-1.

Units are available with safety heights between 150 and 2400 mm. All electronic control and monitoring functions are included in the light curtain profiles. External connection is made via a M12 connection at the end of the profile. Synchronization between transmitter and receiver is achieved optically. No electrical connection between the units is required. Control and monitoring of the beam transmission is carried out by two micro-processors which also give information on the status and alignment of the light curtain via several LEDs.

Muting and Override included in all Focus II

The "Muting" and "Override" functions are available on all Focus II light grids/curtains and is enabled directly when an indication lamp LMS is connected. Muting implies that one or more segments or the whole light curtain can be bypassed during in and out passage of material.

In the Focus II with muting enabled there is also an Override function which makes it possible to bypass the light grid/curtain i.e. activate the outputs if a machine start is necessary even if one or more light beams are interrupted. This is the case when the muting function is chosen and the A and B inputs are activated. If for example during the muting operation a loading pallet has stopped inside the detection zone after a voltage loss, the override function is used to enable the pallet to be driven clear.

Blanking

It is also possible to obtain the Focus II light curtains with blanking. Floating blanking is a tolerance setting that makes it possible to 'disconnect' a defined number of beams from the detection zone. The object is then free to move in the detection zone without the safety function being triggered. Other tolerance settings allows less movement of the interfering object. Blanking may require an additional fixed guard and may require additional minimum distance to the dangerous movement.

Safety outputs OSSD1 and OSSD2

Focus II has two PNP outputs - OSSD1 and OSSD2. If the load to be switched is alternating current or requires a higher current than 500 mA then one should use a safety relay e.g. RT9, Pluto PLC or the FRM-1 unit (converts the outputs to relay contacts) from ABB Jokab Safety. The FMC-Tina and Tina 10A/10B/10C converts the outputs to a dynamic signal for connection to Pluto or Vital. Pluto can also work directly with the OSSD-outputs.

Single/Double Break function

This function is used for presses when the operator prepares or picks out a detail. With the Single Break function the light curtain allows operation after entry and withdrawal out of the curtain. Similarly, the Double Break function allows operation after entry and withdrawal twice.

External Device Monitoring (EDM)

In all light grids and light curtains an EDM function is available which allows Focus II to test if the external control element responds correctly. A test channel is connected through the respective contactor, in order to detect any faults and thereby prevent a reset.

Reset

On every Focus II there are inputs for reset. The reset option is chosen through dual switches in the Focus II receiver. At delivery, Focus II is set to automatic reset.

- Automatic reset – When the detection zone is free the outputs are closed directly. (Setting when delivered).
- Manual reset – When the light field detection zone is free, the reset button has been actuated before the outputs are activated.
- Time reset – To reset the Focus II a pre-reset button must first be actuated and afterwards within 8 seconds a reset button outside the hazardous area must be actuated.

Focus II light curtain

Standard:

- Muting (bypassing) partly or completely
- Supervised output for muting lamp
- Override
- Manually supervised or automatic reset
- Time-reset
- Blanking
- Single/Double Break
- EDM

Focus II light grid

Standard:

- Muting (bypassing) of one, two, three or four beams
- Supervised output for muting lamp
- Override
- Manually supervised or automatic reset
- Time-reset.
- EDM

Option:

- Light grids for tough environments with parallel beams of light for improved reliability.



With the switches at the bottom of Focus II you can choose the function you desire.

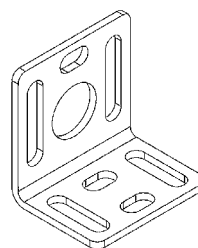

JSM 66
2TLA022090R1300
JSM 66 Bracket for Focus II

Focus II light curtain/grid, Type 4 (FII-4) Summary

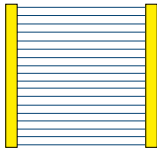
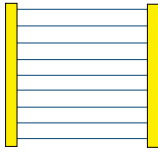
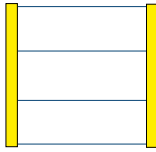
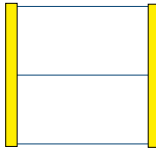
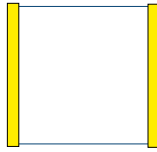
						
Model name	FII-4-14-zzzz	FII-4-30-zzzz	FII-4-K4-zzzz		FII-4-K3-800	FII-4-K2-500
Resolution	14	30				
Beam distance			300	400	400	500
Height (mm=zzzz)	150 300 450 600 750 900 1050 1200 1350 1500 1650 1800 1950 2100 2250 2400	150 300 450 600 750 900 1050 1200 1350 1500 1650 1800 1950 2100 2250 2400	900	1200	800	500
Range (m) SR LR	0.2-3 3-6	0.2-7 7-14	0.5-20 20-40		0.5-20 20-40	0.5-20 20-40
Reaction time off (ms)	18-103	14-47	13		13	13
Reaction time on (ms)	138-104	141-119	142		142	142
Manual reset	•	•	•		•	•
Automatic reset	•	•	•		•	•
Pre reset	•	•	•		•	•
Muting inputs	•	•	•		•	•
Muting lamp supervision	•	•	•		•	•
Override	•	•	•		•	•
Muting T/L/X	• / • / •	• / • / •	• / • / •		• / • / •	• / • / •
Blanking 3 types	• / • / •	• / • / •	- / - / -		- / - / -	- / - / -
Single/Double break	• / •	• / •	- / -		- / -	- / -
EDM	•	•	•		•	•
Dyn. Adaption to Vital/Pluto	☒	☒	☒		☒	☒

• Standard ☒ With Tina 10A/10B/10C or FMC-Tina

NOTE! For ordering data and article number see the product list. For more information see the manual on our home page.

FII-4-K4-zzzz D		FII-4-K3-800 D		FII-4-K2-500 D		FII-4-K2C-zzzz		FII-4-K2C-800		FII-4-K1C-500	
300	400	400	400	500	500	300	400	400	400	500	500
900	1200	800	800	500	500	900	1200	800	800	500	500
0.5-20 20-40	0.5-20 20-40	0.5-20 20-40	0.5-20 20-40	0.5-20 20-40	0.5-20 20-40	0.5-7	0.5-7	0.5-8	0.5-8	0.5-12	0.5-12
13	13	13	13	13	13	13	13	13	13	13	13
142	142	142	142	142	142	142	142	142	142	142	142
•	•	•	•	•	•	•	•	•	•	•	•
•	•	•	•	•	•	•	•	•	•	•	•
•	•	•	•	•	•	•	•	•	•	•	•
•	•	•	•	•	•	•	•	•	•	•	•
•	•	•	•	•	•	•	•	•	•	•	•
•	•	•	•	•	•	•	•	•	•	•	•
•/•/•	•/•/•	•/•/•	•/•/•	•/•/•	•/•/•	•/•/•	•/•/•	•/•/•	•/•/•	•/•/•	•/•/•
-/-/-	-/-/-	-/-/-	-/-/-	-/-/-	-/-/-	-/-/-	-/-/-	-/-/-	-/-/-	-/-/-	-/-/-
-/-	-/-	-/-	-/-	-/-	-/-	-/-	-/-	-/-	-/-	-/-	-/-
•	•	•	•	•	•	•	•	•	•	•	•
□	□	□	□	□	□	□	□	□	□	□	□

Technical data – Focus II

Article number	
Light curtains	
FII-4-14-150	2TLA022200R0000
FII-4-14-300	2TLA022200R1000
FII-4-14-450	2TLA022200R2000
FII-4-14-600	2TLA022200R3000
FII-4-14-750	2TLA022200R4000
FII-4-14-900	2TLA022200R5000
FII-4-14-1050	2TLA022200R6000
FII-4-14-1200	2TLA022200R7000
FII-4-14-1350	2TLA022200R8000
FII-4-14-1500	2TLA022200R9000
FII-4-14-1650	2TLA022201R0000
FII-4-14-1800	2TLA022201R1000
FII-4-14-1950	2TLA022201R2000
FII-4-14-2100	2TLA022201R3000
FII-4-14-2250	2TLA022201R4000
FII-4-14-2400	2TLA022201R5000
FII-4-30-150	2TLA022201R6000
FII-4-30-300	2TLA022201R7000
FII-4-30-450	2TLA022201R8000
FII-4-30-600	2TLA022201R9000
FII-4-30-750	2TLA022202R0000
FII-4-30-900	2TLA022202R1000
FII-4-30-1050	2TLA022202R2000
FII-4-30-1200	2TLA022202R3000
FII-4-30-1350	2TLA022202R4000
FII-4-30-1500	2TLA022202R5000
FII-4-30-1650	2TLA022202R6000
FII-4-30-1800	2TLA022202R7000
FII-4-30-1950	2TLA022202R8000
FII-4-30-2100	2TLA022202R9000
FII-4-30-2250	2TLA022203R0000
FII-4-30-2400	2TLA022203R1000
Light grids	
FII-4-K2-500	2TLA022204R0000
FII-4-K3-800	2TLA022204R1000
FII-4-K4-900	2TLA022204R2000
FII-4-K4-1200	2TLA022204R3000
FII-4-K2-500D	2TLA022204R4000
FII-4-K3-800 D	2TLA022204R5000
FII-4-K4-900 D	2TLA022204R6000
FII-4-K4-1200 D	2TLA022204R7000
FII-4-K1C-500	2TLA022204R8000
FII-4-K2C-800	2TLA022204R9000
FII-4-K2C-900	2TLA022205R0000
FII-4-K2C-1200	2TLA022205R1000
Supply voltage	24 VDC ±20%
Power consumption	
Transmitter	70 mA maximum
Receiver	100 mA maximum
Protective height	Light curtains: 150 mm - 2400 mm Light grids: 500 mm - 1200 mm
Object resolution	Light curtains: 14 mm and 30 mm

PFH _D	2.5x10 ⁻⁹
Light source	Infrared Emitting LEDs, Wavelength 880 nm
Enclosure	Housing: Aluminium painted yellow Front: Polycarbonate Connector: Polyamide End cap: Polyamide
Profile dimensions	37 x 48 mm
Protection class	IP65
Operating temperature	-10 to +55° C
Storage temperature	-25 to +70° C
Safety outputs (OSSD)	Two PNP safety outputs, each sourcing 500 mA 24 VDC. Short circuit protection.
Response time ON to OFF	Maximum: 13-103 ms (depending on model)
Connection transmitter	M12 5-pin male
Connection receiver	M12 8-pin male
Indication	LED's on transmitter and receiver indicating alignment, dirt, power supply and outputs
Safety level	
EN/IEC 61496	Type 4
EN ISO 13849-1	PL e/Cat. 4
IEC 61508	SIL 3
Conformity	EN ISO 12100-1:2010, EN ISO 13849-1:2008, EN 62061:2005, EN 60204-1:2007+A1:2009, EN 61496-1/AC:2010, EN 60664-1:2007, EN 61000-6-2:2005, EN 61000-6-4:2007

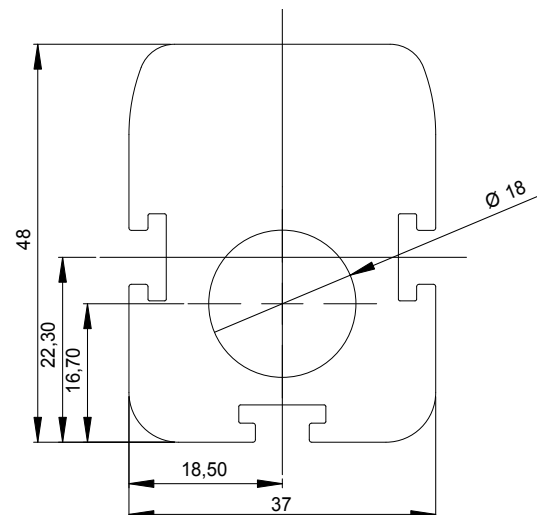

Focus II

Muting (bypassing)

Focus II muting types

- T-muting. Four NO muting sensors are used in two pairs (OR function), allowing bi-directional transport of material. Maximum muting time is 600 s. Muting A and Muting B need an activation time difference of 30 ms.
- L-muting. Two NO muting sensors works together with the light protection, allowing transport out from the hazardous area. Maximum muting time is 600 s. Muting A and Muting B need a activation time difference of 30 ms.
- X-muting. One NO and one NC muting sensor is like a cross through the light protection, allowing bi-directional transport of material. An alternative X-muting (only on Focus Light beams) with 2 NO muting sensor is also possible, but then with the condition of a 30 ms activation time difference on the muting sensors. Both solutions gives an infinite muting time.

Built-in muting for Focus II is available in three ways:

- Pre-made muting units MF-T and MF-L, which have integral photocells.
- Connection of muting sensors via a FMC.
- Separate connection of muting sensors (Mute R) directly to the Focus II receiver unit.

Muting-lamp

To the Focus II receiver unit it is also possible to directly connect a external muting-lamp. It is also possible to connect the muting-lamp via a FMC. During bypassing the muting-lamp is lit. Bypassing is only possible if the muting-lamp is functioning or a resistor of 220 Ohm is used in its place.

Muting with MF-T and MF-L units

MF-T and MF-L are muting units with integrated photocells built into a aluminum profile. They work with all Focus II light grid and curtain. No additional sensors are required because the muting units contain the required components. MF-T/MF-L is connected between the Focus II and the supervising unit (e.g safety relay, safety PLC). The cable between the Focus II and MF-T/MF-L is included with the muting unit.

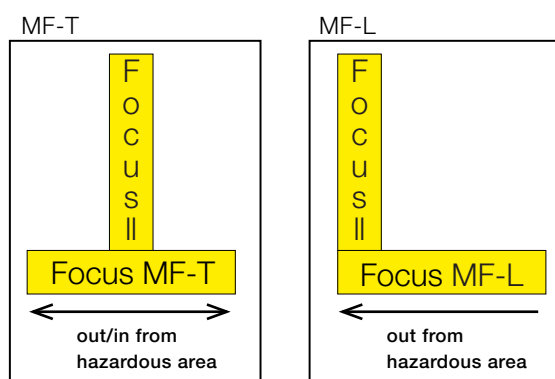

MF-T

The muting unit MF-T consist of a transmitter unit and a receiver unit with four photocells A1, B1, B2 and A2. A1 and A2 are connected in parallel and B1 and B2 connected in parallel. In this way the unit is configured for installations where material is transported into and/or out of a hazardous area.

MF-L

The muting unit MF-L consist of a transmitter unit and a receiver unit with two photocells A1 and B1. The A1 and B1 sensor are actuated before the material is transported through the light grid/curtain. The light grid is an active part in upholding the muting function once A1 and B1 have been passed by the material. The light grid/curtain is being bypassed just as long as the material exiting. Unit MF-L is primarily intended for material transport out of a hazardous area.

MF-T Reflex

The muting unit MF-T Reflex consist of a transmitter/receiver side and a reflector unit. The active side contains four transmitters/receivers photocells. The MF-T Reflex works as the MF-T with a limited range (6m). These units, together with a light grid with one active and one passive side provides a good solution were electrical connections is only necessary on one side!

MF-L Reflex

The muting unit MF-L Reflex consist of a transmitter/receiver unit and a reflector unit. The active side contains two transmitters/receivers photocells. The MF-L Reflex works as the MF-L with a limited range (6m). These units, together with a light grid with one active and one passive side provides a good solution were electrical connections is only necessary on one side!

Focus II

Muting with MF-T and MF-L

A solution with Focus Muting unit MF-T with integrated muting sensors.

Possible direction of movement - in/out of hazardous area.

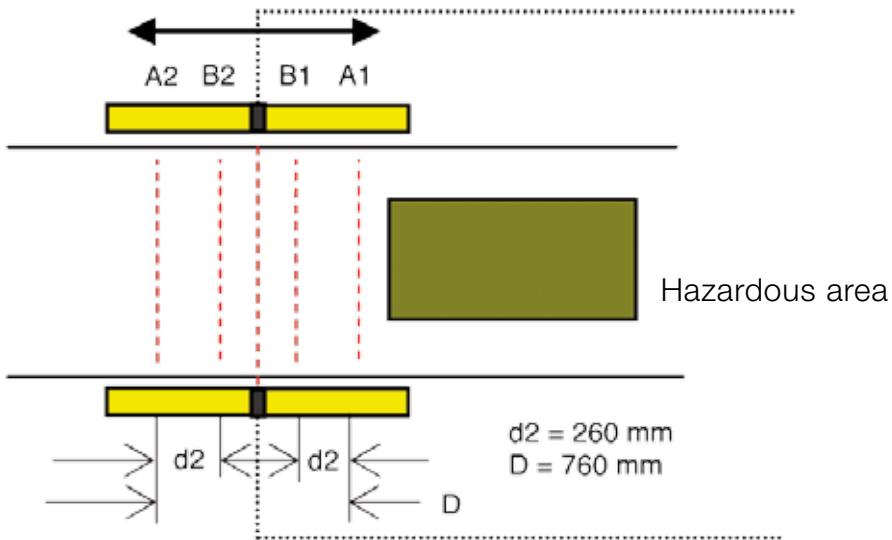

7

A solution with Focus Muting unit MF-L with integrated muting sensors

This solution shall only be used for movement out from a hazardous area.

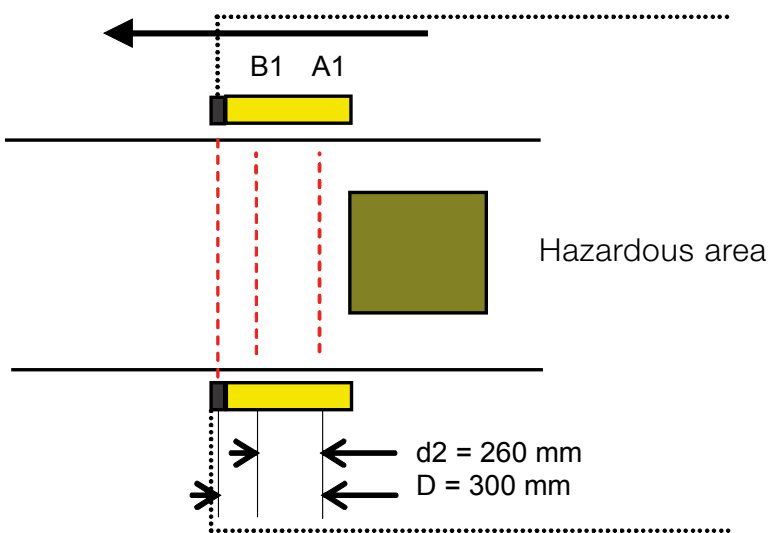

NOTE! The muting sensors A and B must be placed so that the sensor A is always activated at least 30 ms before sensor B.

D: indicates the minimum length of the material that is to actuate the muting sensors that must be maintained during the passage through the light grid/curtain.

d2: indicates the measurement between the two/four pre-assembled muting sensors within the MF-L and MF-T.

Muting sensors – Mute R

Retro-reflective with polarizing filters

Approvals:



Features:

- Range adjustable
- Light reserve warning indicator
- Transistor output, PNP
- 1000 Hz switching frequency
- Short-circuit protection, reverse polarity protection and power-up output suppression
- Connector M12
- EMC tested according to IEC 801 and EN50081-1/EN 50082-2

Technical data

Article number	Mute R (FSTR-1)	2TLA022044R0000
Output	PNP, dark on	
Connection	Connector M12	
Range adjustment	Yes	
Range	0.15... 2.5 m (with reflector FZR 1)	0.15...5m (with reflector FZR 2A)
Light source	Visible-red, 660 nm, pulsed with polarizing filter	
Supply voltage	10...30 VDC	
Allowable ripple	± 10% of Us	
Current consumption (without load)	<15 mA	
Max. load current	100 mA	
Residual voltage	<1.6 V	
Max. switching frequency	1000 Hz	
Protection class	IP67	
Temperature (operating and storage)	-25 to +65° C	
Weight	approx. 15 g	

All technical data at 25° C and 24V.

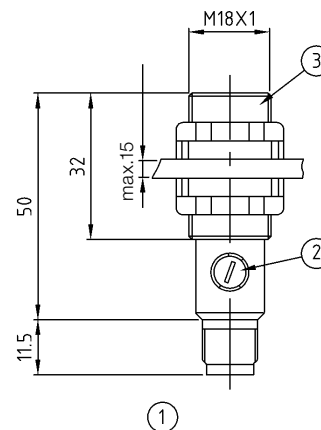

1. Connector M12
2. Range adjustment and function indicator
3. Plastic housing

PNP output

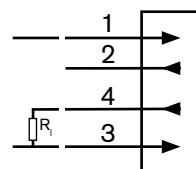

- 1 (+) Supply voltage 10...30 V
- 4 Dark-on output
- 3 (-) Supply voltage

Dark-on output

The output is activated when an object interrupts the light.

Connector M12

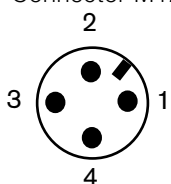

10...30 VDC
PNP
Dark-on output

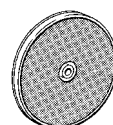
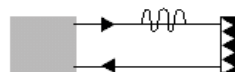

FZR 1 2TLA022044R0100
Reflector Ø 80 mm incl.screw MC6S M5 x 14 + Locking nut M5.

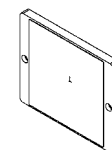

FZR 2A 2TLA022044R0400
Reflector 100 x 100 mm incl. screw MC6S M5 x 14 + Locking nut M5.

Muting with Mute R

A solution with two sensors and one movement direction for material transport:

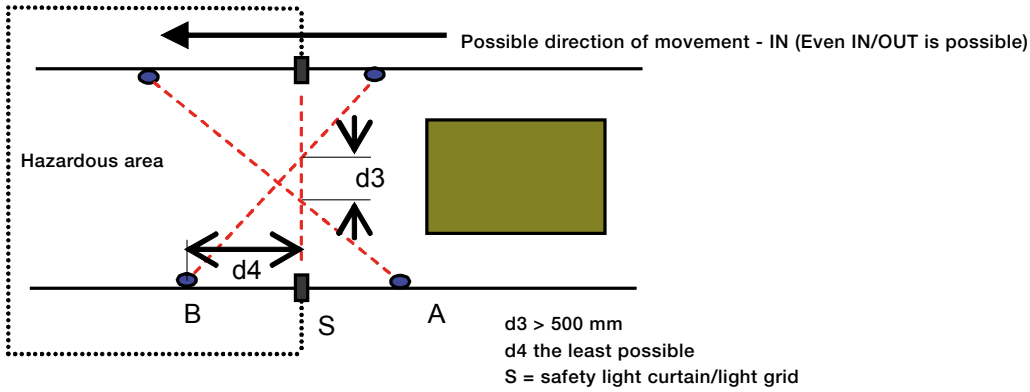

A solution with four sensors and one movement direction for material transport:

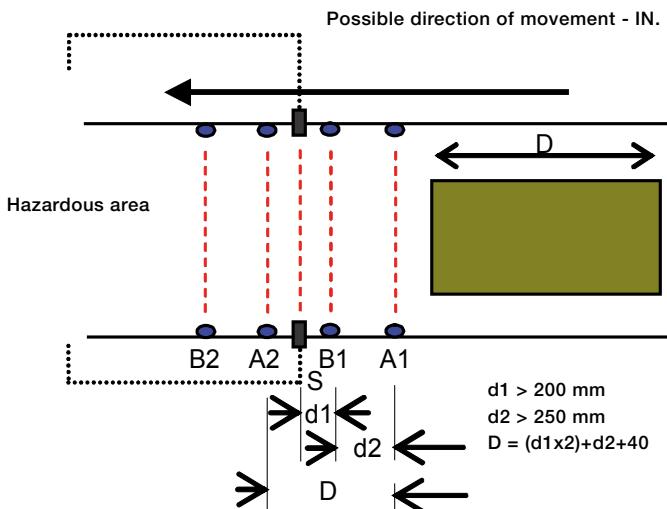

A solution with four sensors and two movement directions for material transport:

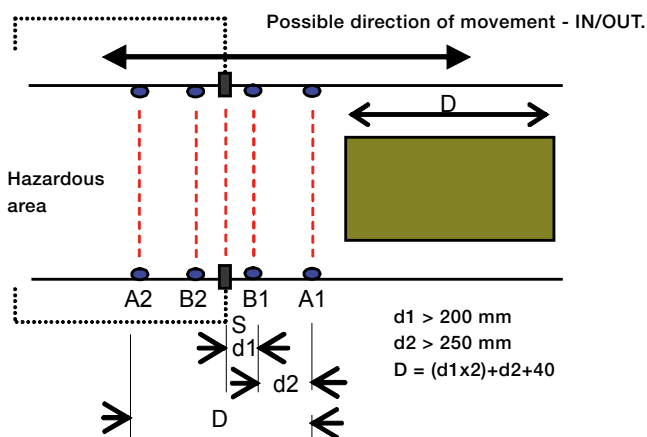

D: indicates the minimum length on the material that is to actuate the muting sensors that must be maintained during the passage through the light grid/curtain.

$d1$ must be as short as possible, and definitely less than 200 mm
 $d2$: indicates the distance between A1 and B1

Muting accessories FMC and FMI units



Approvals:



Application:

- FMC: Muting connection box
- FMI: Muting Indicator

Features:

- Small
- Easy to connect

Various FMC, FMI, FRM- versions and Tina units

The Tina-versions have dynamic safety outputs for Vital/Pluto.

Model	Description
FMC-1(2)	with connectors for muting sensors (A+B), reset, power off and muting lamp (R) and muting lamp (M).
FMI-1A	with muting lamp only.
FMI-1B	with reset, power off and muting lamp.
FMI-1C	with reset and power off.
FMI-1D	with reset, power off and internal resistor for the muting lamp.
FMI-1E	as pre reset connected to connector A (A2) on FMC-1(2) (Tina).
FMI-1G	with reset, and internal resistor for the muting lamp.
FMC-1 (2) Tina	same as FMC-1(2) but connected to Vital or Pluto.
Tina 10A	adaptor unit for connecting Focus II to Vital or Pluto.
Tina 10B	simplified FMC-1(2) Tina including only the connector (R).
Tina 10C	simplified FMC-1(2) Tina including only power supply on con.no.3.
FRM-1A	translates the two OSSD outputs to relay outputs (and power supply).
JS SP-1	protection plug for not used connectors.
JS AP-1	adaptor for FMC units to use instead of FMI-1B or -1D on the (R) connector including muting resistor.

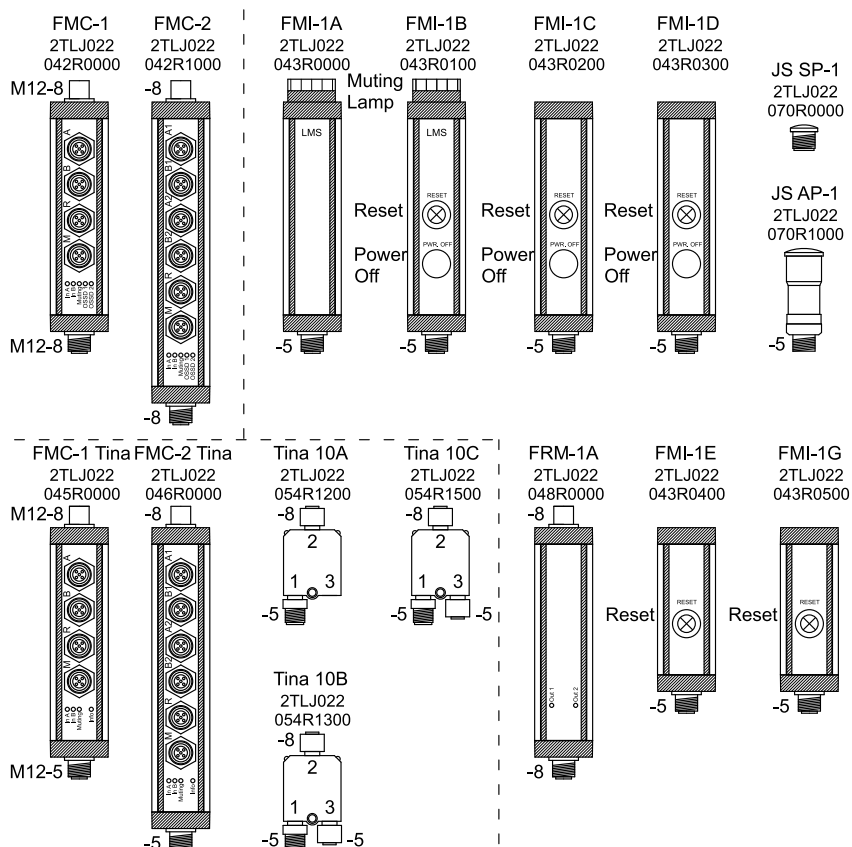

Muting with FMI and FMC

Connection of Focus II and muting components as FMC and FMI

Ex 1. Connection of light curtain with connection block FMC-1, test/reset button and switch for supply voltage placed in (by) the control cabinet.

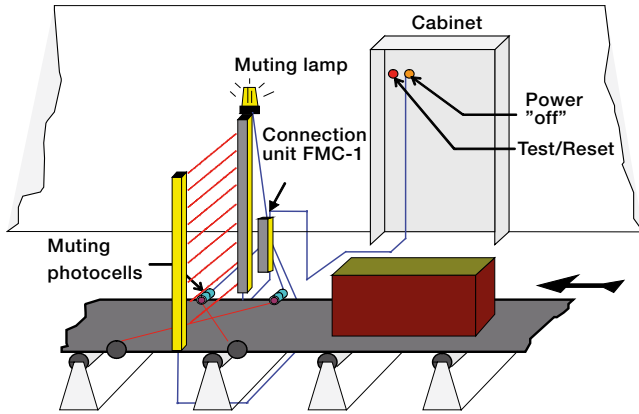

Ex 2. Connection of light curtain with connection block FMC-1. The Reset unit FMI must be placed out of reach from the hazardous area.

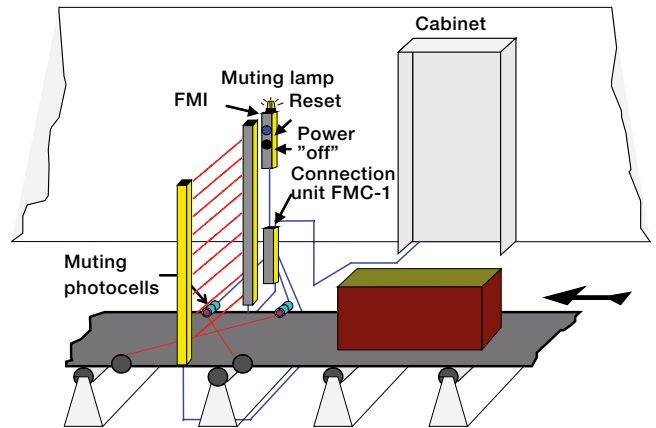

7

Connection of Focus II and muting components directly to the control cabinet

- The TEST /RESET button shall be placed so the operator can see the protected area during reset, testing, and bypassing. It shall not be possible to reach the button from within the hazardous area.
- The LMS lamp for indication of muting and bypassing shall be placed so that it can be seen from all directions from where it is possible to access the hazardous area.
- If photocells are used as muting sensors then the sensor receivers shall be assembled on the light curtain's transmitter side to minimise the interference risk.
- The system is protected against dangerous functions caused by damage on the transmitter cable and/or the receiver cable. However, we recommend that the cables be protected so that physical damage to them can be minimised.

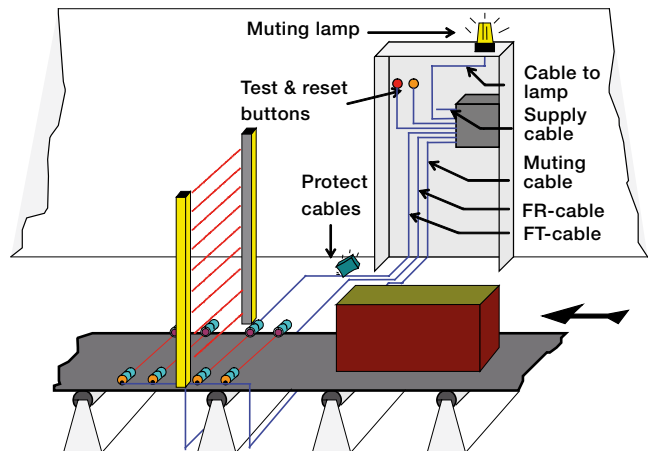

Accessories

MFI mirrors for light curtain

Technical data – Mirrors

Type	Article No	Height mirror glass, mm	Height total, mm
MFI-300	2TLA022041R0200	356	361
MFI-450	2TLA022041R0300	506	511
MFI-600	2TLA022041R0400	653	658
MFI-750	2TLA022041R0500	796	801
MFI-900	2TLA022041R0700	953	958
MFI-1050	2TLA022041R1200	1103	1108
MFI-1200	2TLA022041R0800	1253	1258
MFI-1350	2TLA022041R1300	1403	1408
MFI-1500	2TLA022041R0900	1546	1551
MFI-1650	2TLA022041R1000	1703	1708
Bracket for MFI mirrors.	2TLA022041R2000		

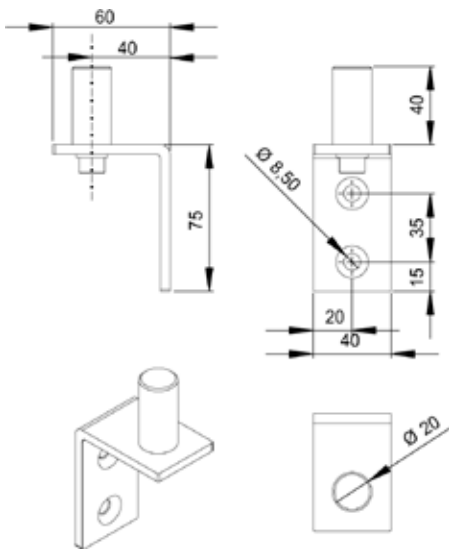

Bracket for MFI mirrors. 2 pcs needed for each mirror.

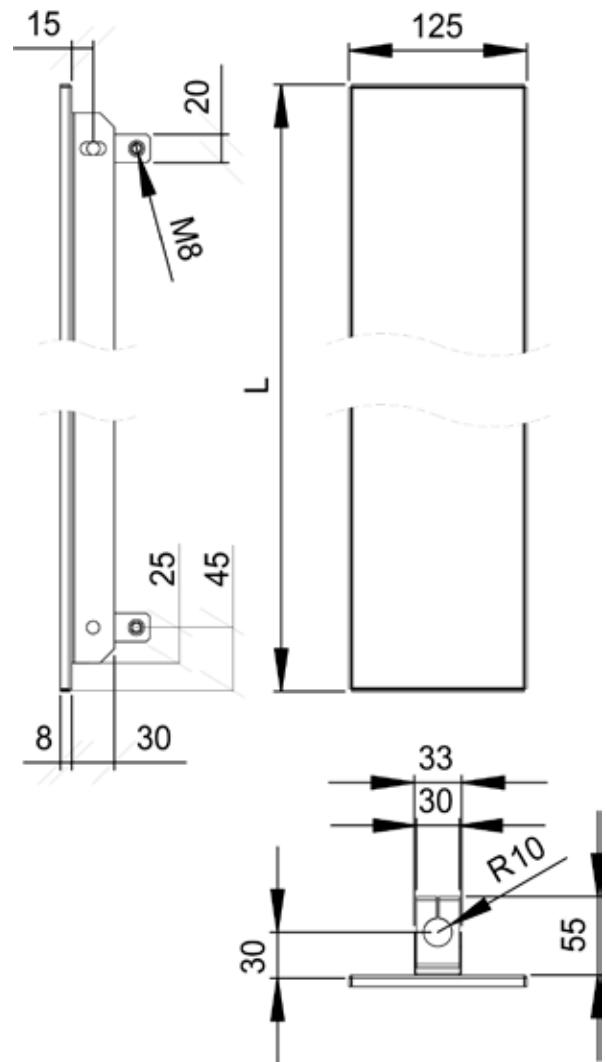

Adjustment plate

JSM 70, 2TLA040001R1500.
Plate for easy adjustment on uneven floors.

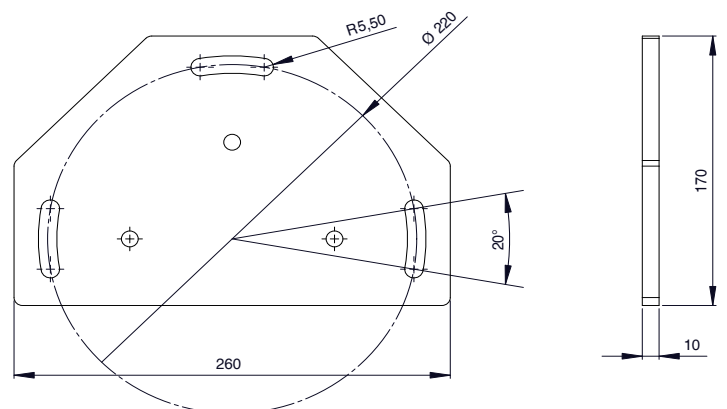
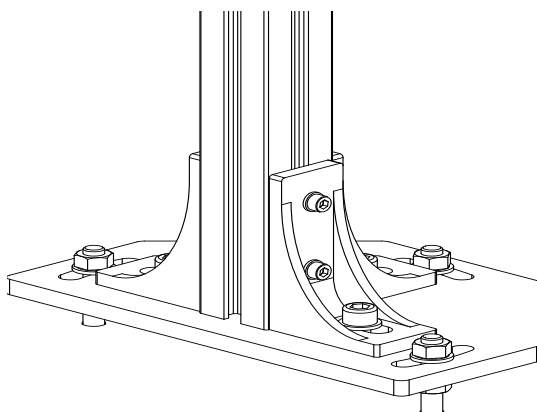

Light protection stand Bjorn



Application:

- Protects light curtain, light grids and mirror

Features:

- Robust
- Adjustable

7

Bjorn is a very stable and flexible stand system in which Focus II safety light grids/curtains and mirrors are mounted in the stand. The fixings for the mirrors in the stand can be turned to provide either vertical or horizontal angles. The robust material of the Bjorn protects Focus II units from direct collisions, and thus prevents unnecessary material damage and halts in production.

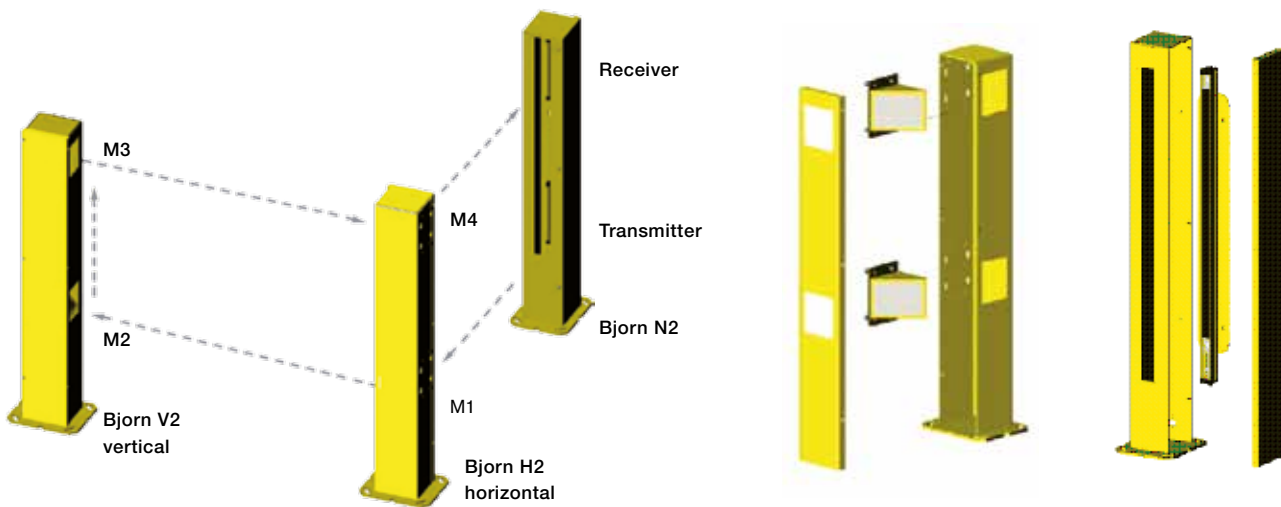

Technical data – Bjorn

Article number	
Bjorn H2	2TLA022041R4000
Bjorn V2	2TLA022041R4100
Bjorn H3	2TLA022041R4200
Bjorn H4-1	2TLA022041R4300
Bjorn H4-2	2TLA022041R4400
Bjorn N2	2TLA022041R4500
Bjorn N3	2TLA022041R4600
Bjorn N4-1	2TLA022041R4700
Bjorn N4-2	2TLA022041R4800
Bjorn N5	2TLA022041R4900
H = Horizontal reflection V = Vertical reflection N = For the light guard unit	
Colour	Yellow powder-coated (RAL 1018)
Material	3 mm steel
Dimensions	
Cross section	146 mm x 130 mm
Foot	230 mm x 190 mm
Weight	
N2	14 kg/piece
H2, V2	15 kg/piece
N3	17 kg/piece
H3, N4-1	18 kg/piece
H4-1	20 kg/piece
N4-2:	22 kg/piece
H4-2	24 kg/piece
N5	27 kg/piece
Mirror reduction	~10 % per mirror

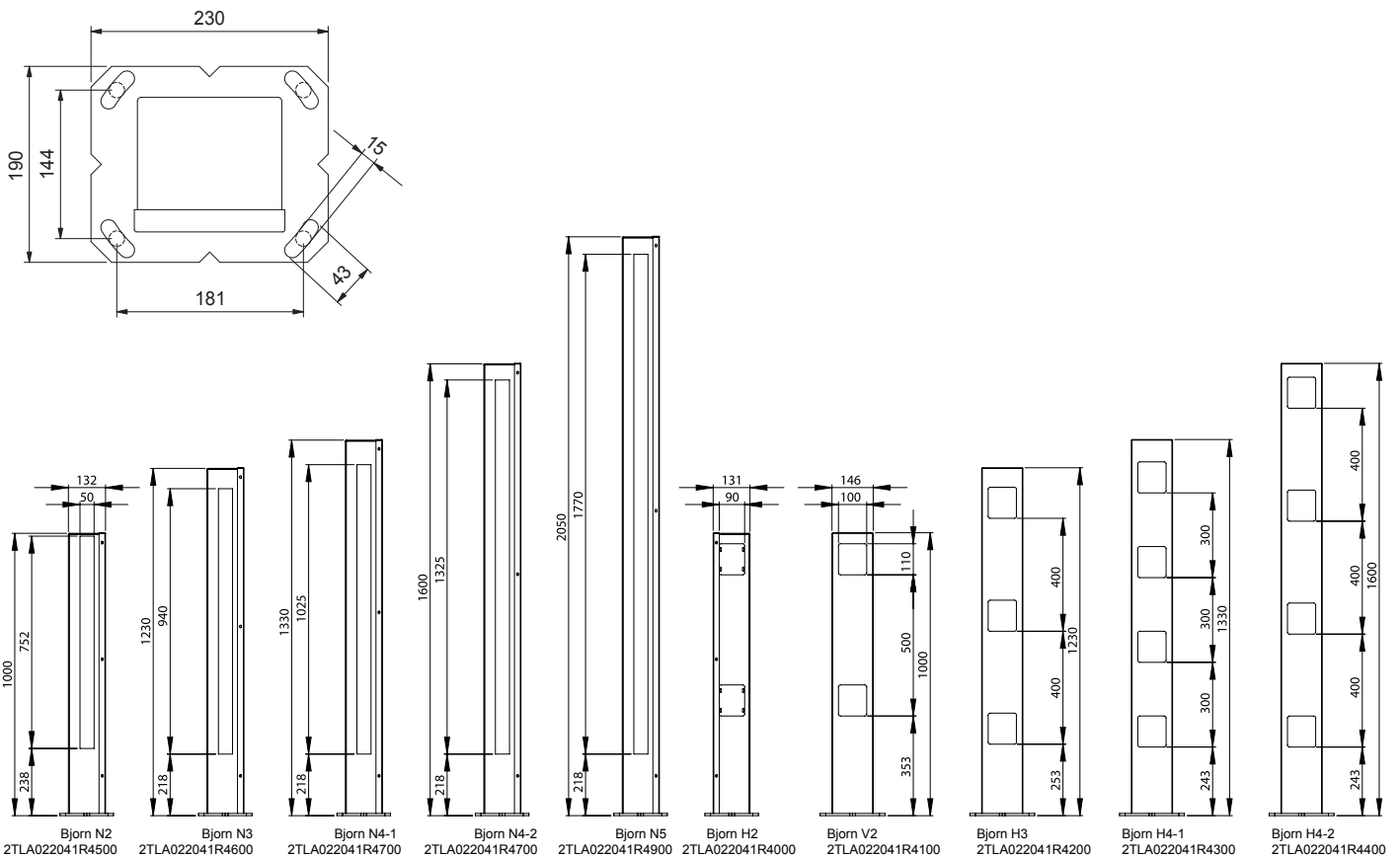

Protection against water and dust

WET



Application:

- Protection in severe environments

Features:

- Adjustable
- IP68

7

Technical data – WET

Article number	
WET-150 FII	2TLA022038R4000
WET-300 FII	2TLA022038R4100
WET-450 FII	2TLA022038R4200
WET-600 FII	2TLA022038R4300
WET-750 FII	2TLA022038R4400
WET-900 FII	2TLA022038R4500
WET-1050 FII	2TLA022038R4600
WET-1200 FII	2TLA022038R4700
WET-1350 FII	2TLA022038R4800
WET-1500 FII	2TLA022038R4900
WET-1650 FII	2TLA022038R5000
WET-1800 FII	2TLA022038R5100
WET-K-500 FII	2TLA022038R5200
WET-K-800 FII	2TLA022038R5300
WET-K-900 FII	2TLA022038R5400
WET-K-1200 FII	2TLA022038R5500
WET-L FII	2TLA022038R5600
WET-T FII	2TLA022038R5700
Colour	Transparent plastic
Length including lid	light curtain/light grid + 54 mm
Material	
Tube	PC
Lid	PEHD-300
Angle bracket	Stainless steel
Max. ambient temperature	+55°C
Installation adjustment	± 20°
Protection rating	IP68 (IP69K)

WET is used for protection against water (or dust) where extreme washing conditions are encountered. The protective encapsulation rating (IP68) now enables Focus II light curtains and light grids to be used for such applications as the food industry where the use of high pressure washing for cleaning machinery often occurs.

WET, with Focus II light curtains or light grids, is pre-assembled complete with cabling, on request. During installation on a machine a WET unit can be adjusted by ± 20° with the accompanying angle bracket.

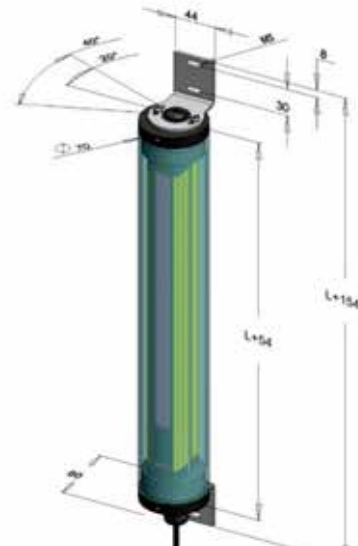

Blanking programmer BP-1



Application:

- Program blanking

Features:

- Easy to connect
- Can stay fitted during operation

Technical data – BP-1 Blanking programmer

Article number

BP-1 Blanking programmer

2TLA022090R2300

Colour

yellow and black

Programming blanking is made easy by using the Blanking programmer BP-1. The BP-1 is easily connected between the receiver unit of the light curtain and the cable otherwise connected to the receiver. The blanking object is placed in the light curtain detection zone and the button on the BP-1 is then pressed. 11 seconds later blanking is programmed for the object.

If the object needs to be changed a new programming is needed.

The unit can stay fitted during operation if required.

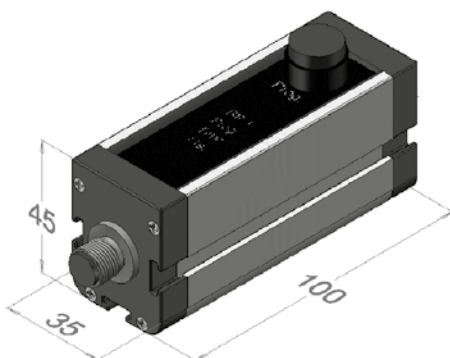

Connection examples

HR7000C-01 Focus II - Connection without and with muting function

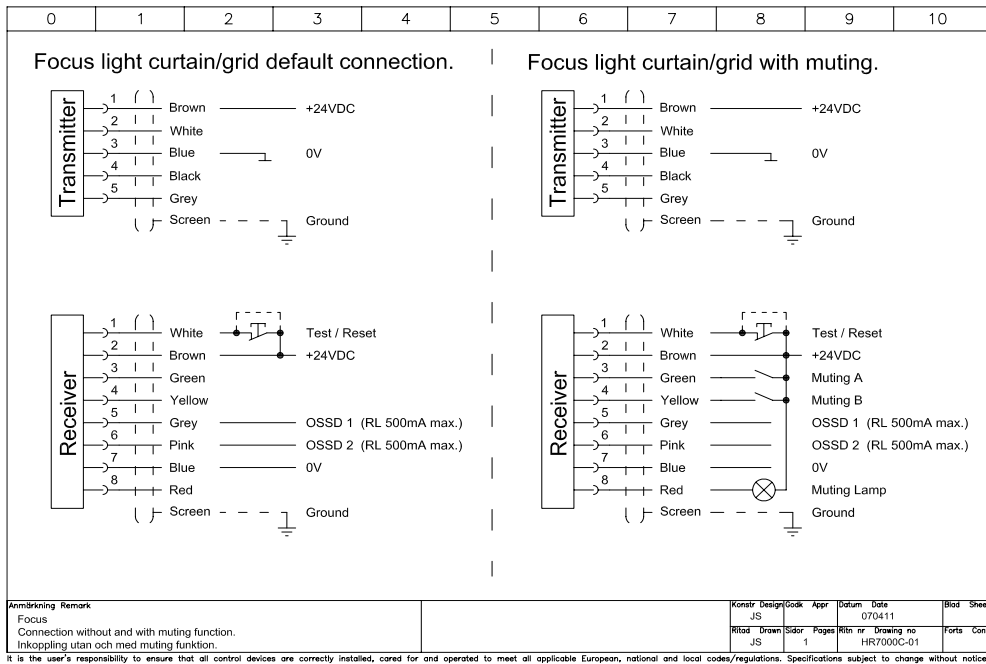

HR7000E-01 Focus II - Connection with pre-reset function

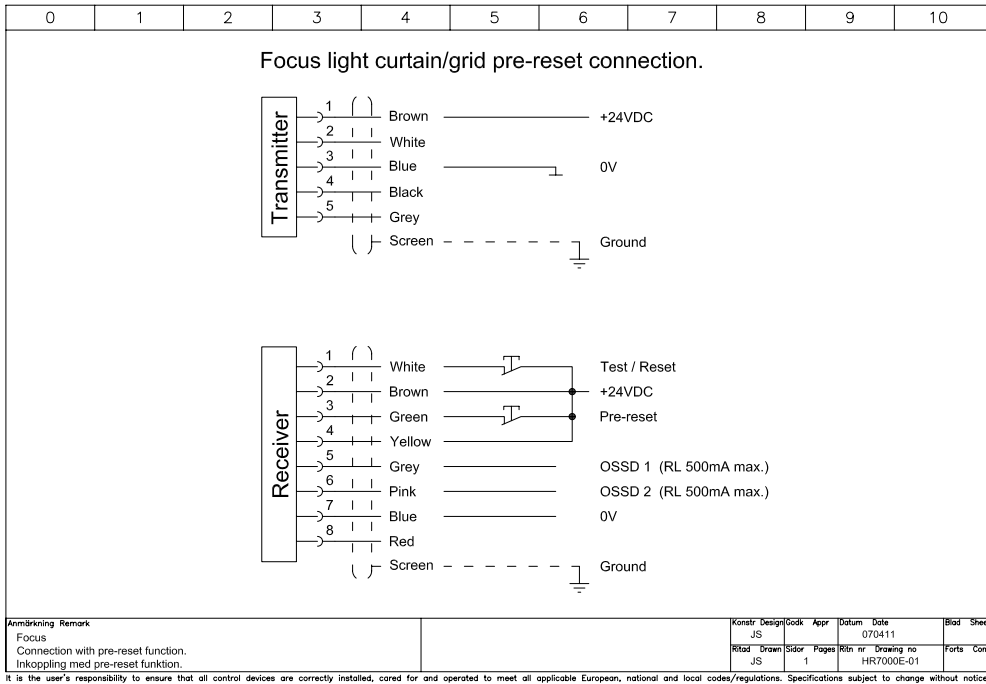

Connection examples

HR7000F-01 Focus II - Connection with muting to safety relay

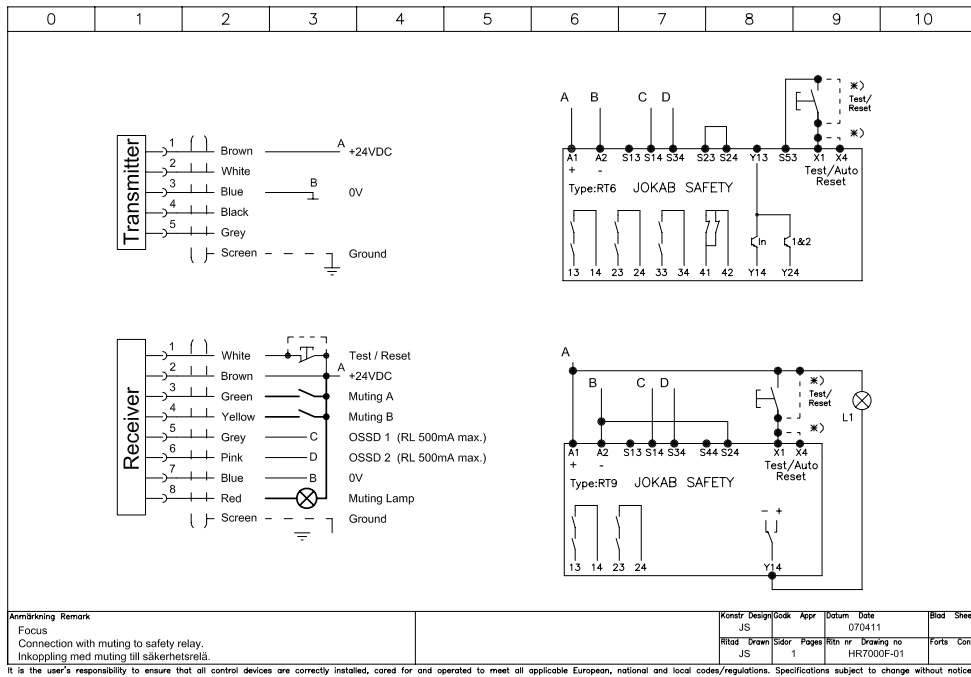

HR7000G-01 Focus II - Connection with MF-T/MF-L units

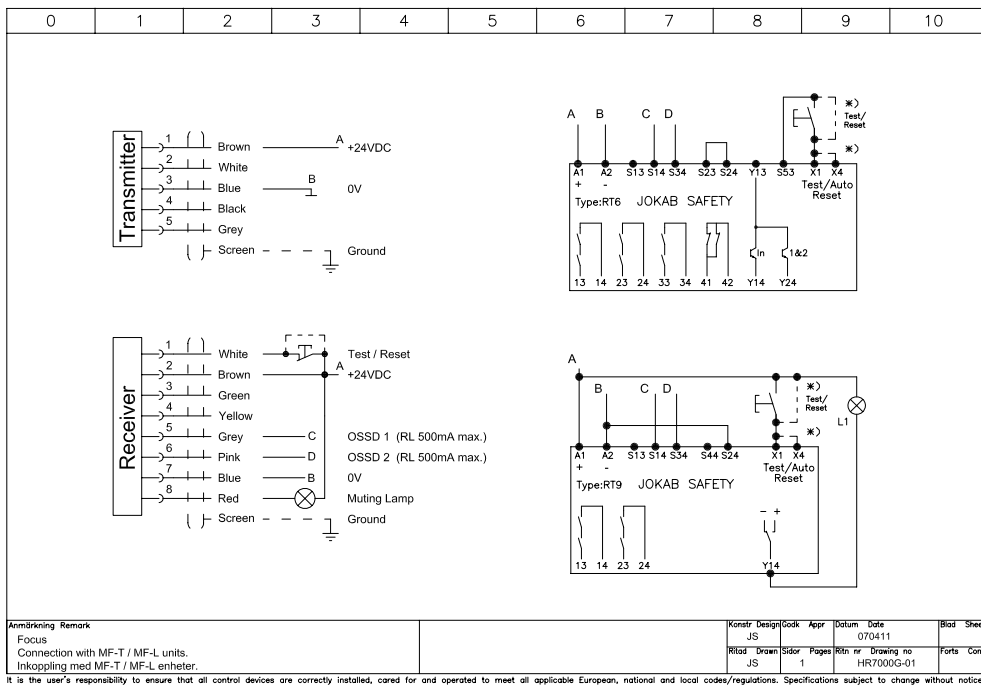

Connection examples

HR7000H-01 Focus II - Connection with FMC/Tina Interface

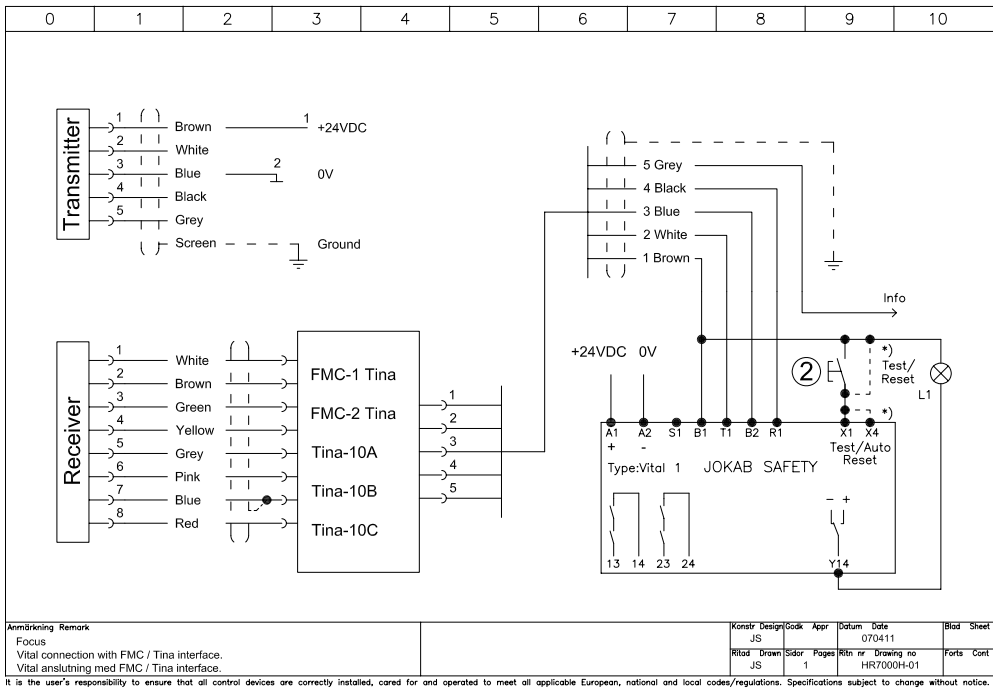

FMC - Connection possibilities

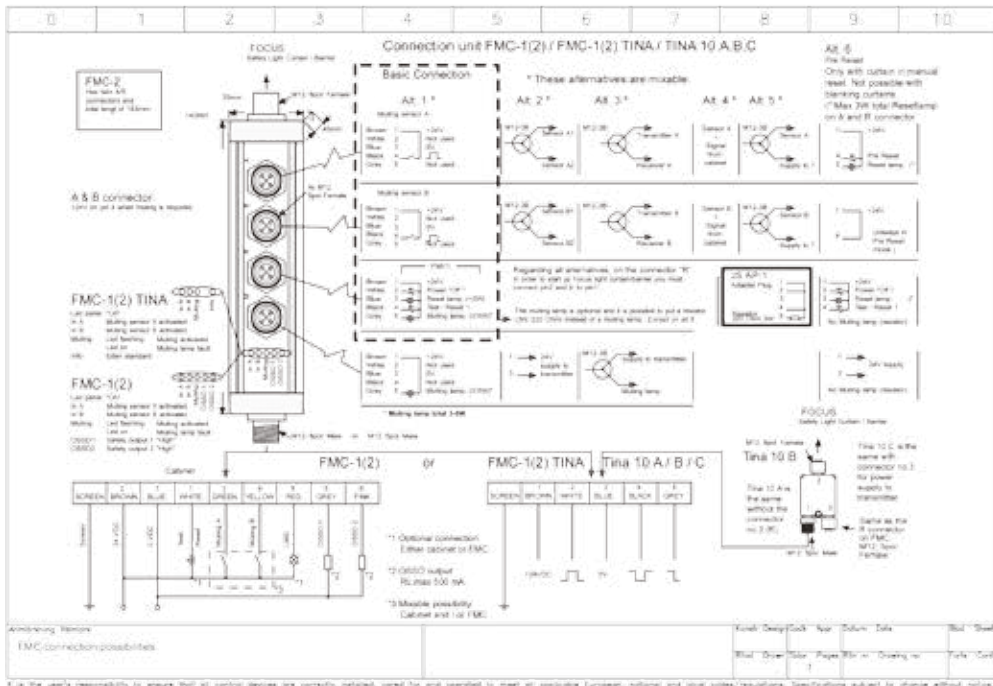

Connection examples

HR7000J-01 FMC-1 or FMC-1 Tina with muting sensors and reset unit

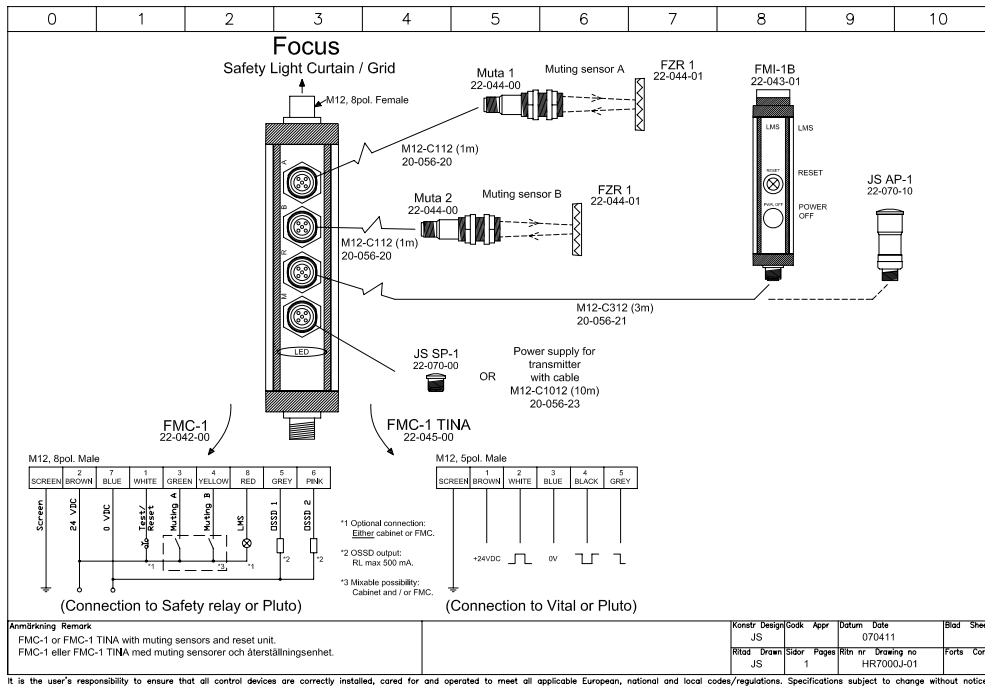

HR7000K-01 FMC-1 or FMC-1 Tina connected with Pre-Reset

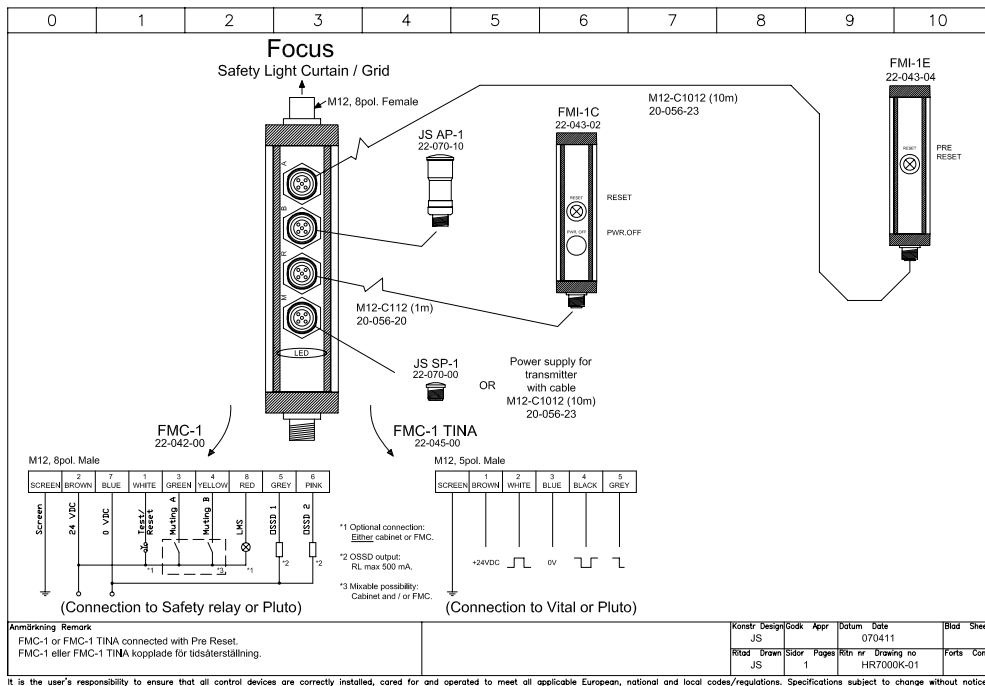

Connection examples

HR7000L-01 Tina 10A, 10B and 10C connection example

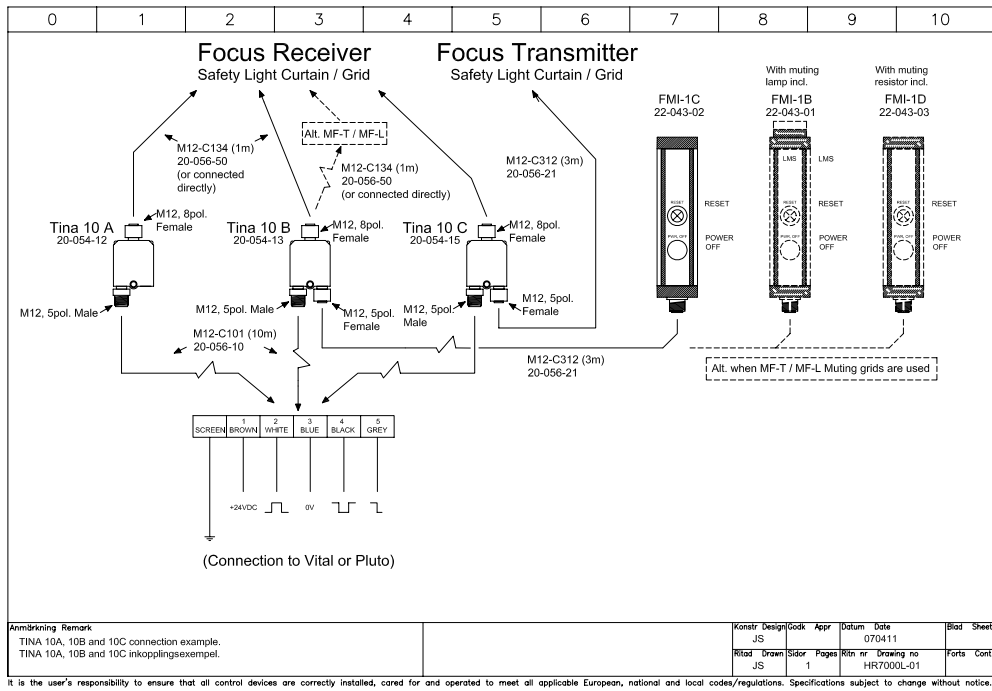

7

HR7000M FRM-1 - Changing OSSD outputs to relay contacts

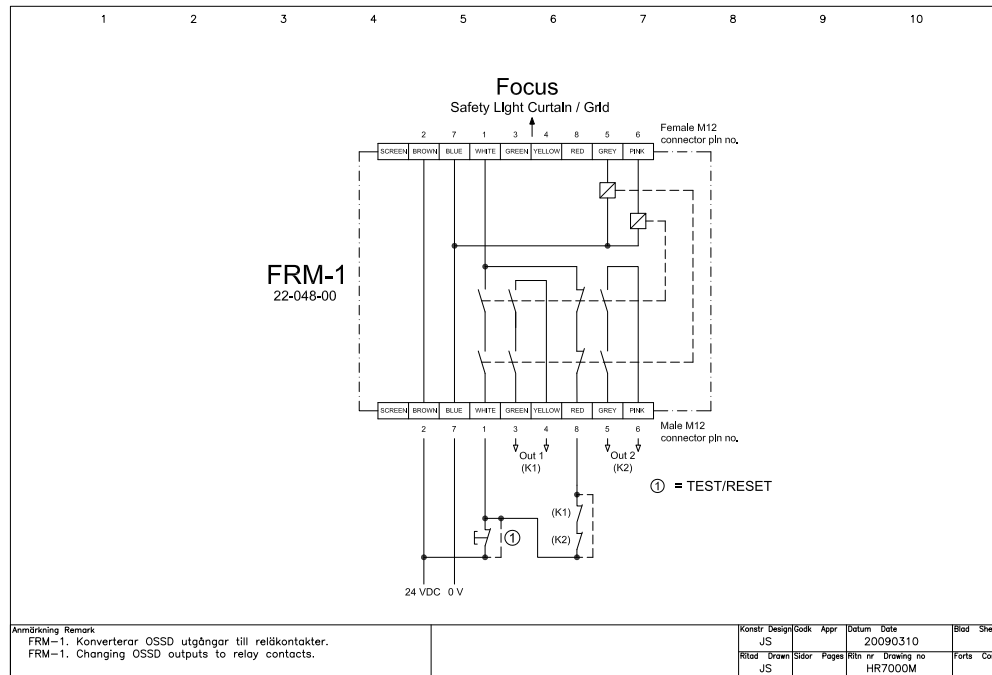

Connection examples

HR7000-01 Connection example FMC/FMI

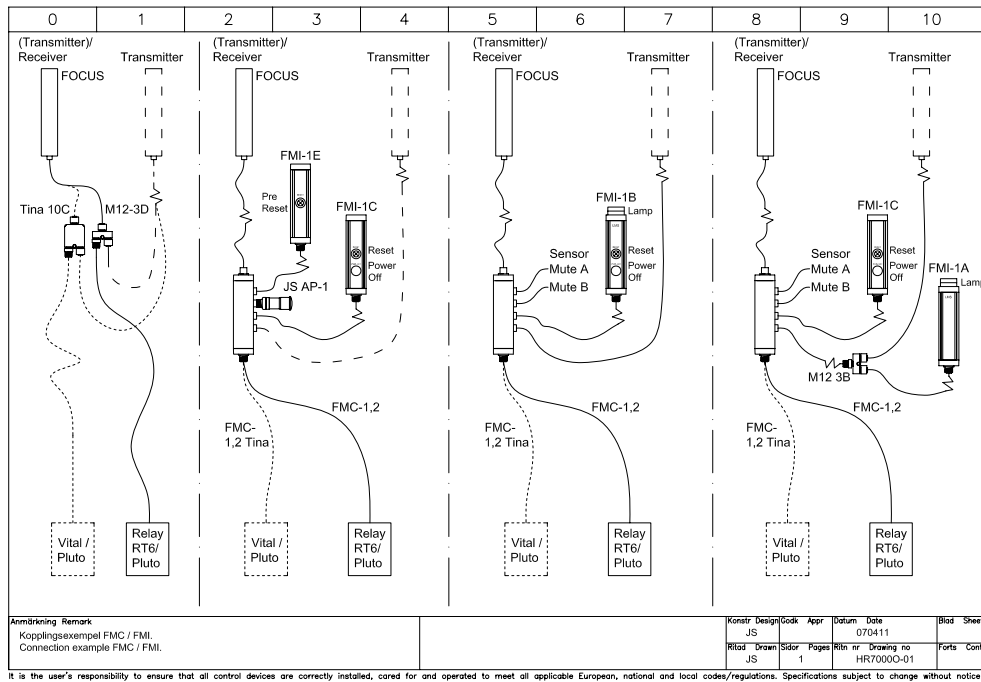

HR7000P Cable connection example

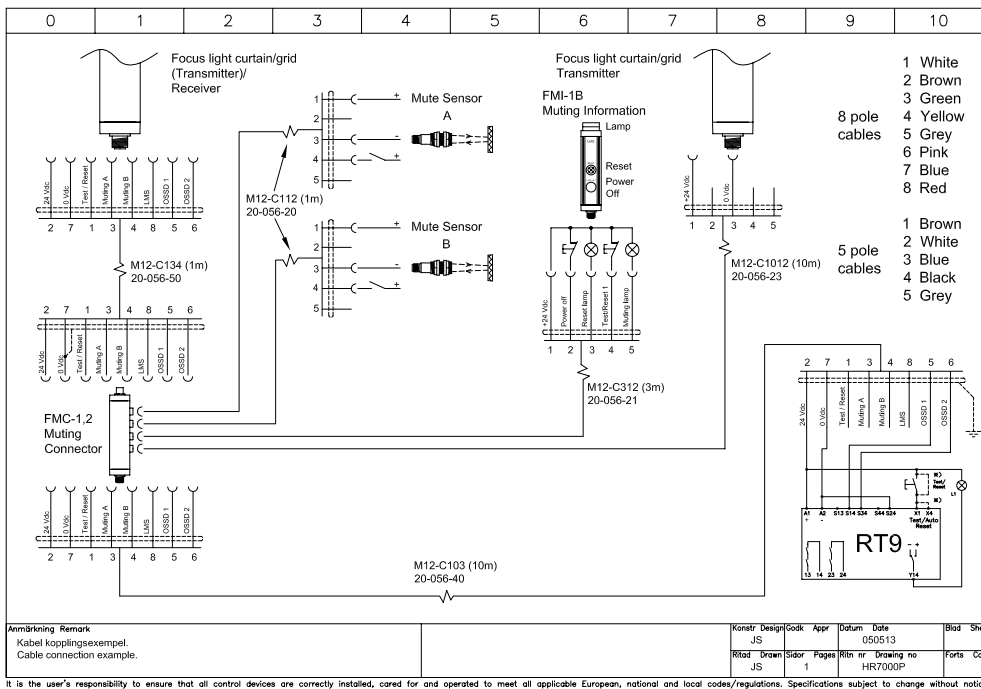

Connection examples

HR7000Q Cable connection example

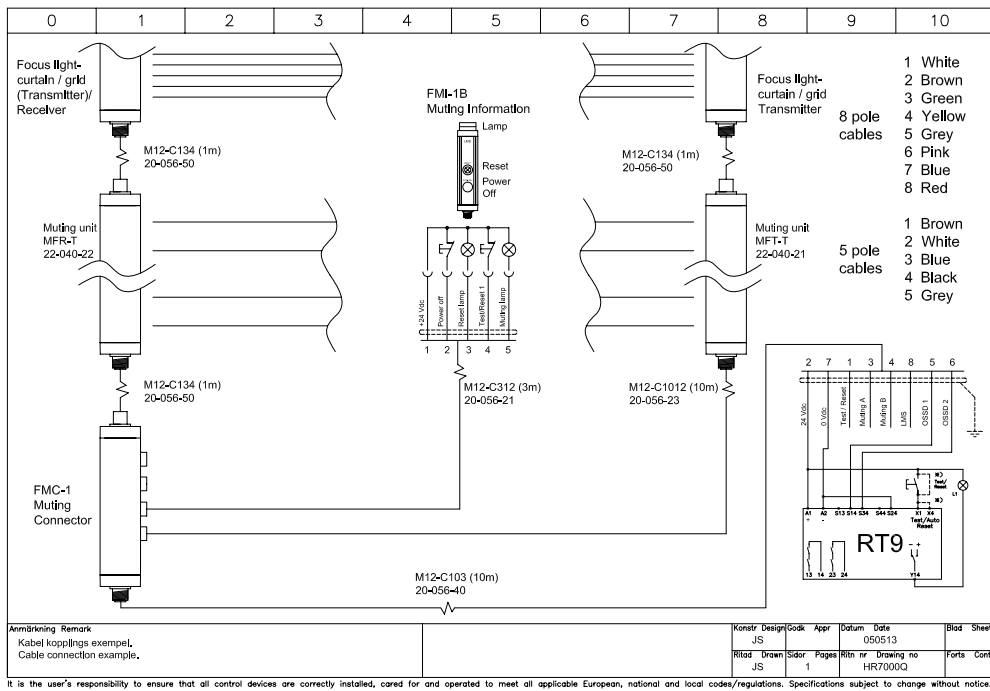

HR7000S Focus II; Muting with the aid of Pluto, FMC and a transfer cable

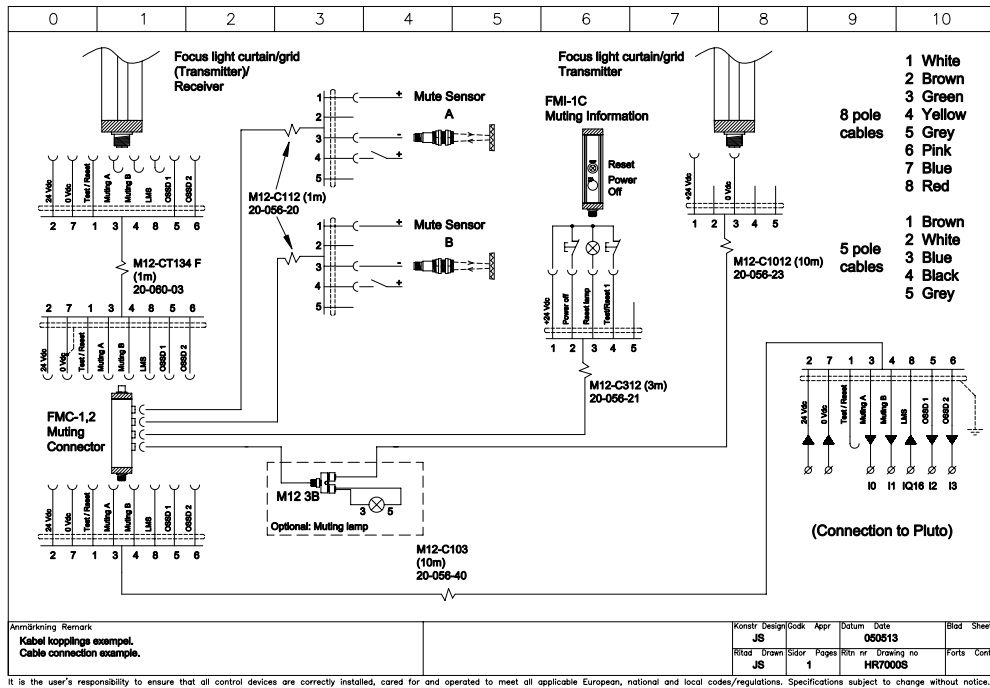

Safety Light Beam Spot



Approvals:



Application:

- Photoelectric guarding of an entrance or around a risk area

Features:

- Safety level Type 4 according to EN 61496
- Versatile mounting
- LED indication
- IP67
- 10 m or 35 m range
- Bypassing possibility
- Light beam, emergency stop and Eden in the same safety circuit together with Vital/Pluto achieves PL e according to EN ISO 13849-1

A light beam for the highest safety level

The light beam is available in two versions Spot 10 for distances up to 10 m and Spot 35 for up to 35 m. The light beams can be mounted at different heights and be angled around a machine using our mirrors and brackets.

Spot and Vital/Pluto in combination fulfils the requirements for PL e according to EN ISO 13849-1 and type 4 according to EN 61496. Several light beams, Eden sensors and emergency stops can be connected in series achieving the high safety level for the safety circuit. A number of solutions for bypassing of light beams for material transport are available.

For indication there are LED's on the transmitter and on the receiver which indicate 'contact' between transmitter and receiver and safety status. The 'contact' information is available via the light beam receiver connection cables.

Function

The Spot light beam is supervised by the Vital safety controller or by the Pluto safety-PLC. A unique coded signal is sent out from the control unit to the transmitter (Spot T). The signal which comes back from the receiver (Spot R) is then compared in the Vital/Pluto. If the correct coded signal is received the Vital/Pluto switches the necessary safety output contacts to permit dangerous machine movements. Coding guarantees that no output signals can be produced by light from other sources, interference or faults in components in the transmitter or receiver. The light beam is dynamically

supervised which means that if the signal stops pulsating at the correct frequency it is immediately detected. By means of coding, the dynamic signal can pass between up to 6 pairs of transmitters and receivers, with only one pair needing to be electrically connected to a Vital.

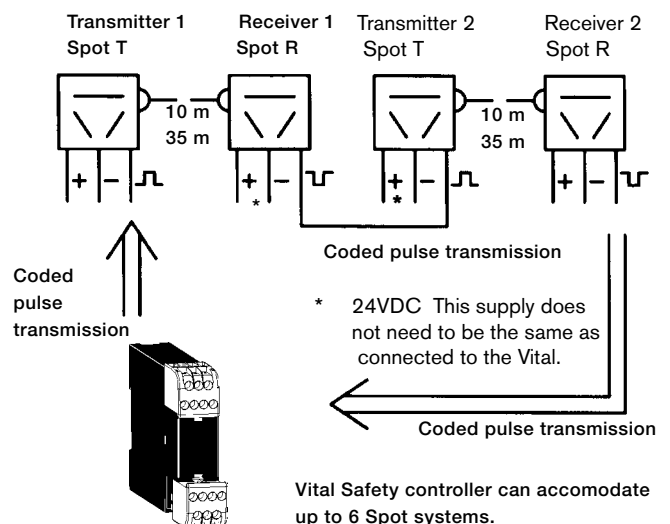

Spot Mounting and alignment

Safety distance

The basic principle is that dangerous machine movements should be stopped before a person reaches the dangerous area, which should be at least 850 mm from the light beams. When determining the correct safety distance the stopping time of the machine and the risk level must be taken into account (see also EN ISO 13855).

Accessories and Mounting

The Spot light beam can be mounted using a variety of brackets, posts and mirrors.

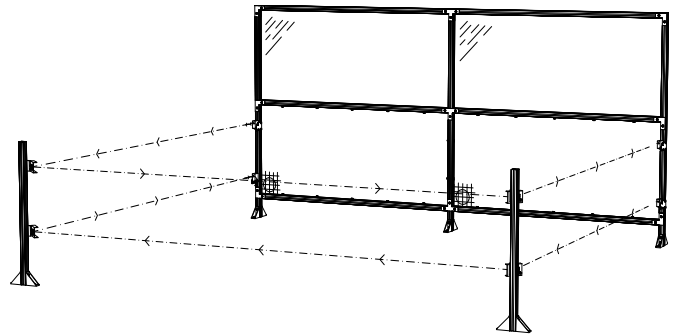

7

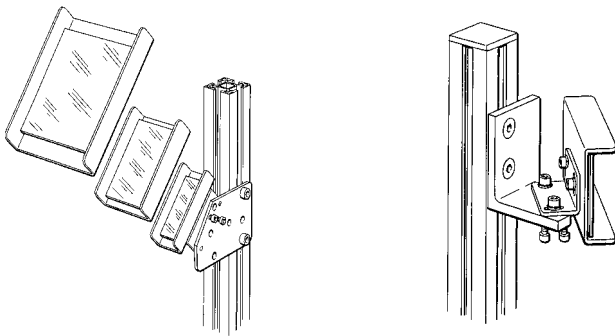

Different sizes of mirrors, mounting brackets and profiles are available.

NOTE! Every mirror reduces the sensing distance of the beam by approx. 20%.

Alignment

When aligning the light beam, look towards the transmitter. In the lens will be seen a strong red light. When this light is seen from the receiver (via mirrors if fitted) the light beam is basically aligned. The LED on the receiver is on when the receiver is aligned with the transmitter. By moving the transmitter up/down and left/right the best alignment can be found.

When vertically mounting, (as shown in the diagram) the receiver should be mounted above the transmitter as this will simplify the alignment and minimise the risk of extraneous light disturbance. In exceptional light disturbance environments the received light can be adjusted by a screw on the rear of the Spot 35 receiver. On Spot 10 this adjustment can be made on the transmitter.

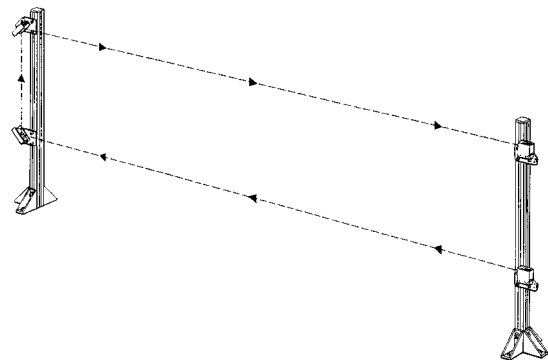

JSM64

Pivot M18 bracket for Spot 10 or MUTE R (FSTR1) for example

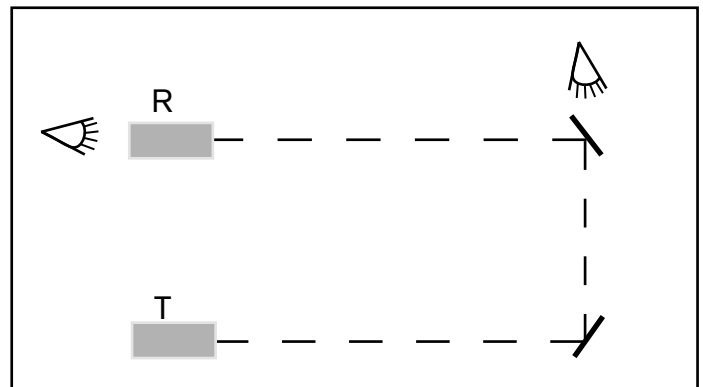
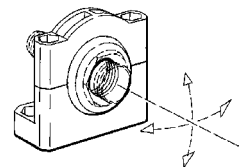

Technical data - Spot

Article number	
Spot 10 T/R	2TLA020009R0600
Spot 35 T/R	2TLA020009R0500
Safety level	
EN/IEC 61496	Type 4 with Vital/Pluto
EN ISO 13849-1	PL e/Cat. 4
PFH_D	1.14x10 ⁻⁸
Power supply	
	17 – 27 VDC, ripple ±10%
Current consumption	
Transmitter	< 25 mA
Receiver	< 15 mA
Output currents	
Info. output	10 mA max.
Dynamic signal out	30 mA max.
Light source	
	Red visible light, 660 nm, <±2°
Optical power	
Spot 10	< 0.1 mW
Spot 35	< 0.2 mW
LED indication	
Green LED on transmitter (power)	Power supply OK
Green LED on receiver status	
On	Alignment OK, safety circuit closed
Flashing	Alignment OK, earlier safety circuit open
Off	Beam interrupted, safety circuit open
Protection class	
	IP67
Range	
Spot 10	0 - 10 m
Spot 35	0 - 35 m
Range adjustment	
Spot 10	Trim pot. on transmitter
Spot 35	Trim pot. on receiver
Installation	
Spot 10	2xM18 nuts (provided)
Spot 35	Either via mounting holes in the casing or with angle bracket JSM63 (provided)
Operating temperature range	
	-25°C – +65°C
Cable connection	
	M12 fixed connector
Casing Material	
Spot 10	Steel housing with polyacryl lens protection.
Spot 35	Polyamide housing with polyacryl lens protection.
Colour	
Spot 10	Steel grey
Spot 35	Yellow/black
Weight	
Spot 10	2 x 21 g
Spot 35	2 x 100 g

Connections	
Transmitter:	
Brown (1)	+24 VDC
White (2)	Dynamic signal in
Blue (3)	0 VDC
Receiver:	
Brown (1)	+24 VDC
White (2)	
Blue (3)	0 VDC
Black (4)	Dynamic signal out
Grey (5)	Info output
	24 VDC when LED is green or flashing (tolerance -2 VDC)
	0 VDC when LED is off (tolerance +2 VDC)
Conformity	
	EN ISO 12100:2010, EN ISO 13849-1:2008, EN 62061:2005, EN 61508:2010, EN 60204-1:2006+A1:2009, EN 61496-1:2004+A1:2008, EN 60664-1:2007, EN 61000-6-2:2005, EN 61000-6-4:2007
Certifications	
	TÜV Nord, cCSAus

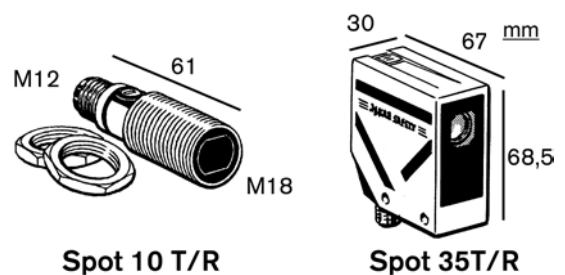

Connection examples

HD3800A-01 Connection of Spot T/R to Vital1

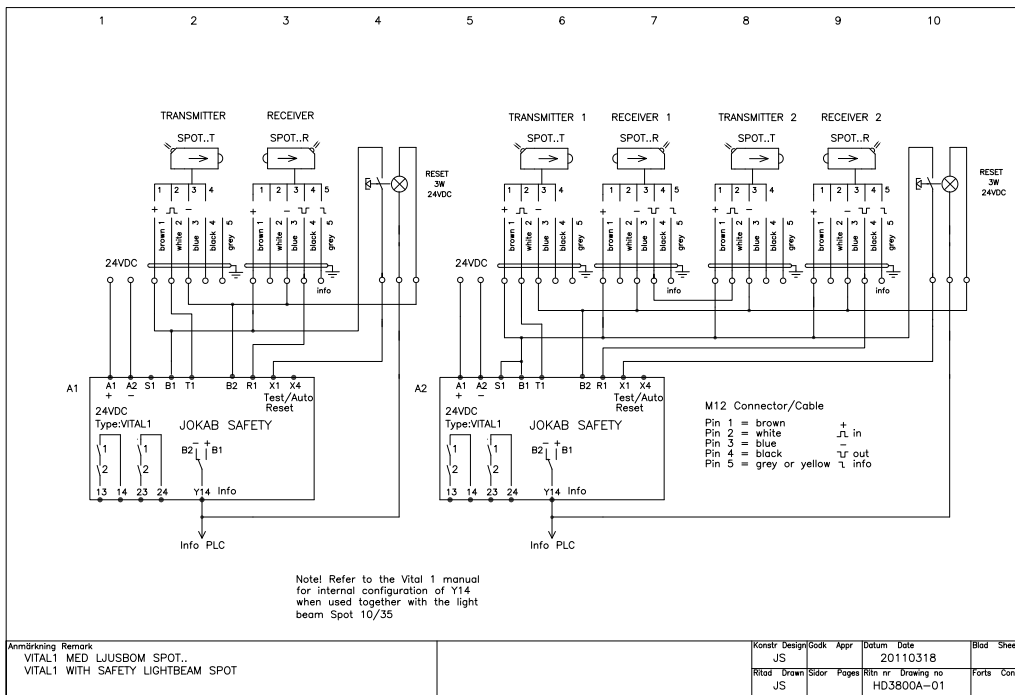

7

HA3306D Vital 1 with 3 lightbeams Spot

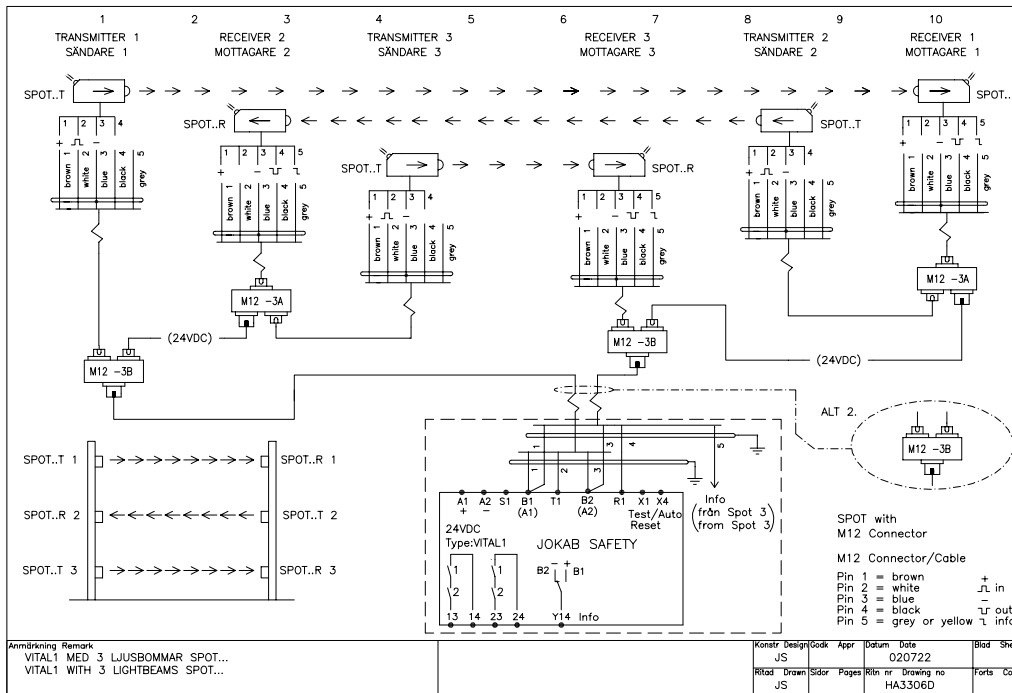

*For more connection examples see chapters for Vital or Pluto



Stopping time and machine diagnosis tool

Smart

Why measure stopping time?	8/3
Smart	8/4
Smart Manager	8/5
Smart and accessories	8/7

Stopping time

Why measure stopping time?

– to find out which safety arrangements can be used in a certain area around a machine, and where they should be located.

Stopping time

The safety distance (how far away from the risk area a safety component must be placed) is based upon the machines stopping time. The basic idea is that a safety component should be placed so far from the risk area that it is not possible to enter the area before the machine has stopped.

The stopping time for manually operated machines is especially important when light beams and light curtains are used as safety components. By reflex action the operator tries to grab or adjust if something has gone wrong in the machine tool, even if the machine has started. It is then imperative that the machine stops before the hand reaches the risk area. A short stopping distance is also of importance for getting good ergonomics.

Grabbing or adjusting is also common when using automatic machines. Usually this is done to prevent production downtime by quickly adjusting a work piece. The stopping time is also of great importance if someone trips and falls into the machine.

Stopping time, walking speed (1.6 m/s) and hand speed (2.0 m/s) is used for the calculation of safety distances. Sometimes a fixed minimum distance is also used. See the standard EN ISO 13855 for more details on the calculation of safety distances.

Stopping distance

For safety contact strips it is extra important that the stopping distance is monitored. An incorrect stopping distance could in many cases result in very high risks. The stopping distance is also needed during area limiting e.g. for robots when dividing the working area into sectors.

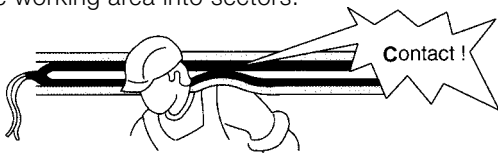

For door sensitive edges, it is important that the stopping distance is shorter than the soft part of the sensitive edge.

Regulations and standards

It is also important to measure the stopping time, to meet the requirements set by the machinery standards, directives and regulations. Here we can help, with our long experience in the practical application of regulations and standards, from the viewpoints of both the authorities and production. In addition we collaborate with the standardisation committees responsible for producing these standards. One example is



Where the safety distance is small, one can for example sit close to the machine and work, as in the picture on the left. If the safety distance is greater, it may be necessary to approach the machine to intervene, and also perhaps use additional protection to prevent starting when someone is within the protected distance.

EN ISO 13855, which deals with the placing of safety devices around a machine based on its stopping time. The standard is general for all types of machinery, although for some, where there is a harmonised C standard, the requirements for minimum distance and stopping time measurement will apply. In the case for example of mechanical press tools there is also a requirement in EN 692 for how stopping time measurements are to be performed, and in the case of hydraulic press tools this is in EN 693.

Annual checks

Wear in a machine is something that can affect braking and motors, which means that the stopping time of a machine can change with time. Certain other changes in a machine, such as changing the weight of a workpiece or alterations in pneumatic pressure, can also affect the stopping time. For these and other reasons it is important to perform an annual check on the stopping time.

How the stopping time affects the choice of protective equipment – an example

There was a case where we measured the stopping time of the rollers in a textile industry company. The company had planned to place light beams or a light curtain in front of the rollers to prevent the operators from being caught in the material and dragged in. The stopping time measurement showed that it took over one second for the rollers to stop. During this time the material was pulled in by almost two metres. In order to obtain sufficient protection distance, the light beams would have needed to be positioned almost three metres from the machinery, and a light curtain about two metres away. The factory did not have so much space, nor was it realistic. The solution became instead vertical sliding safety barriers.

Stopping time and Machine Diagnosis Tool Smart

Approvals:



Smart shows graphs/
values for:

- Stopping time
- Stopping distance
- Speed
- Position of stopping signal

Features:

- Easy to use
- Measurements with or without electrical connection
- Ideal for machine performance diagnosis
- Calculation of correct safety distances

Smart is ideal for safety supervision and for diagnosis of machine operation

Smart has many valuable features for machine diagnosis:

- Graphic presentation of measurements
- Easy to analyse stopping characteristics and movement
- Gives parameters for safety design (e.g. stop time)
- Calculates minimum allowed safety distance
- Shows how the stop distance can be optimised
- Electrical reaction time and mechanical/hydraulic breaking can be identified and analysed
- Digital in/out signals and analogue inputs

Smart is perfect for periodic monitoring of safety parameters and other conditions for the maintenance and trouble-shooting of machines. Because Smart can compare old and new graphs, it becomes easy to find out the reasons for machine malfunctions. One can also supervise machines during operation and compare how they perform over time.

Stopping units and sensors

Smart is a further development of our well established JSSM1 Stopping Analyser. All the stopping units and sensors for the JSSM1 can also be used with Smart. The amount of connection possibilities have also increased. Smart has 9 digital I/O, one input for an incremental sensor (for position and speed) and two analogue inputs. This makes it easy to measure sequences in conjunction with motion lapse and other analogue values.

Smart Manager

Smart is controlled in real time by a computer using the Smart Manager program. This performs measurements, and the measured data can be saved and analysed. The measurements are saved in an SQL database, with the ability to export data to Microsoft Excel if necessary. The program calculates the stopping time and protective distance, and can print out the results, together with a graph of the event sequence. Smart Manager is available in several languages: English, Swedish, Danish, German, French, Czech and Polish. Translation into other languages can easily be arranged as necessary. The program is free, and is available for downloading from our web site when purchasing equipment to measure stopping times.

Benefits:

- Simple program structure
- Shows the entire stop sequence
- Provides a machine movement "fingerprint"
- Compares measurements
- Calculates stopping time
- Saves measurements to a database
- Exports measured data to Excel
- Prints out a complete measurement report

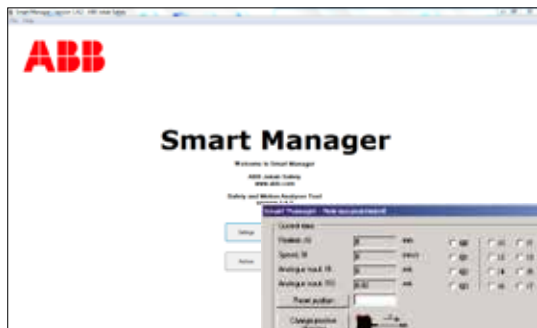

Start menu

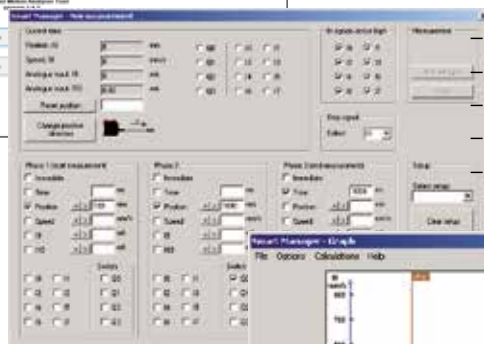

Measuring form

- Current values from sensors and the system
- Start conditions
- Stop signal conditions
- Shutdown conditions
- Measuring settings can be saved

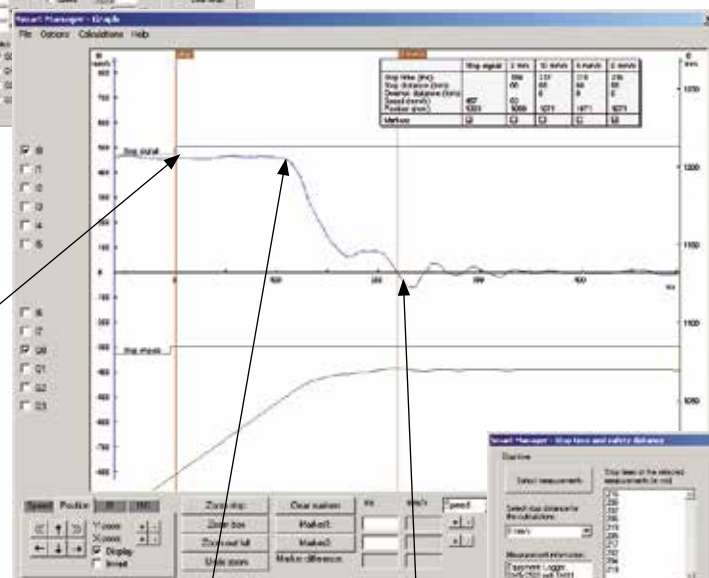

Stop signal given

- Stop time data
- Zoom control
- Own cursors

Measured result

Relay contacts drop out

Machine stopped



Calculations

- Min., max. and average value and standard deviation from a series of measurements
- Protective distance can be calculated



Saving

- Select measurement series
- State extra information, e.g. the conditions and special circumstances for the measurements.



Archiving

- Search filter
- Saved measurements
- Exported measurements

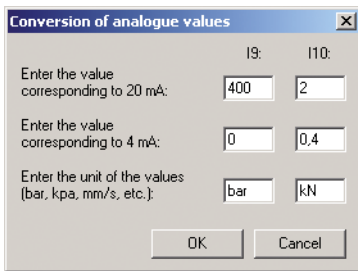

Conversion of analogue signals

Smart can measure and show graphs for two different analogue sensors at the same time, with its inputs for 0/4-20 mA. Conversion of the measured current values can be done automatically by setting minimum and maximum values and the units for the inputs. In this way, for example, the results from an analogue pressure sensor can be shown and calculated as 0-400 bar instead of 4-20 mA, or an analogue load cell as 0-2 kN. This also means that if it is desired for the system to be triggered at a certain force, that force can be defined instead of needing to calculate the equivalent current value.

Printout

Printing out is one of the most important functions of the program. Here is shown all the vital information about the measurements that is needed for such items as annual checking or providing the basis for CE labelling of a machine. Since the entire measuring sequence is shown in graphical format, one can understand why the stopping time has a certain value and also, in some cases, see what needs to be done to minimise the stopping time. The graph also acts as a kind of "fingerprint" of the machine movements, which means that different measurements can be compared with each other to see how the stopping sequence varies from time to time, or from year to year. In this way the effects of e.g. worn brakes or the effect on the machine control system can be seen. In order to get a complete basis from a measurement it is also important to state what assumptions have been made and what conditions applied when deciding when and how the stop signal was given.

Among other things, the stop signal details the person measuring, the measuring equipment, the machinery, the calculations and the protective distance. The printout also has a replaceable company logo and a field for extra information.

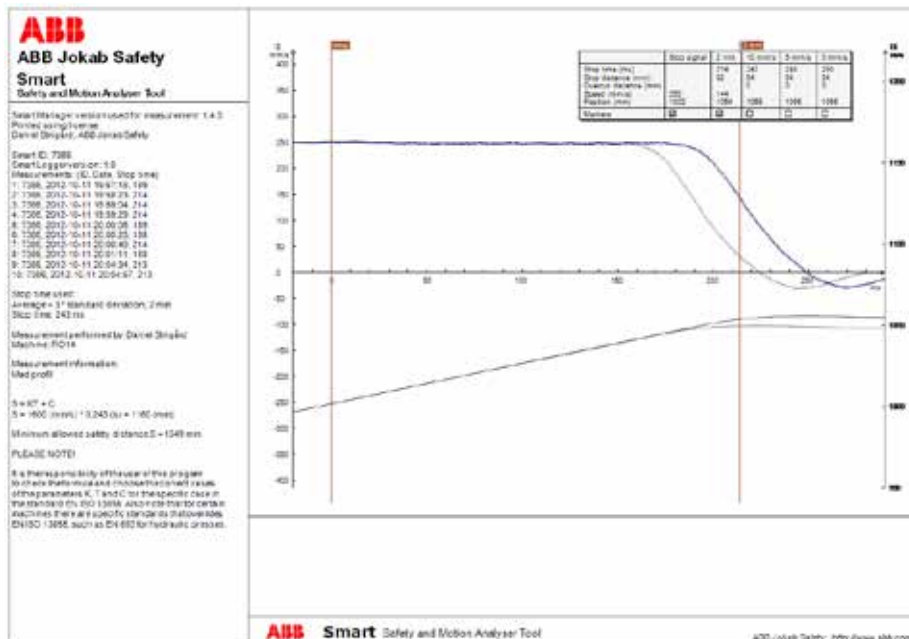

Smart and accessories

Smart Logger

Article number	2TLA070300R0100	<p>The Smart Logger is the principal unit for data collection. The logger has a USB connection to the PC and 8 M12 connections: one for the power supply to the I/O, one connection for an incremental sensor, two connections for analogue sensors and four connections for other I/O signals.</p> <p>The Logger encapsulation is watertight, with M12 connections to prevent the entry of particles and fluids in the workshop environment. To prevent the Smart Logger from being damaged by incorrect currents and voltages from external equipment, all inputs and outputs, and external units, are electrically isolated from the processor in the Smart Logger by means of opto-couplers.</p>	
Dimensions	62 x 220 x 80 mm. (wxhxd)		
Weight	0.5 kg		
Protection class	IP67		
Supply voltage	24 VDC		
Response speed	max 1 ms		
Positional accuracy	+/- 0.1 mm		
Digital I/O	8 inputs, 4 outputs (NPN OC)		
Analogue inputs	2 off, 0/4-20 mA		
Encoder	1 connection for a pulse sensor		

SM2 Button unit

Article number	2TLA070300R0200	<p>The SM2 is used in conjunction with the Smart Logger for measuring with a manual stop impulse, without an electrical connection to the machine. When an SM2 is, for example, pressed against an emergency stop button to stop the machine, the SM2 sends a signal to the Smart Logger to start the measurement. An LED on the SM2 lights when the desired stop position is reached. The SM2 is connected to the Smart Logger by an M12 connection.</p>	
Dimensions	Size: 50 x 100 x 25 mm. (wxhxd)		
Weight	0.2 kg		
Application area	Two-handed control unit, Emergency stop, etc.		
Supply voltage	Fed from the Smart Logger		

SM3 Relay unit

Article number	2TLA070300R0300	<p>The SM3 is used in conjunction with the Smart Logger for automatic stopping time measurements at the set position, or alternatively a manual stop pulse. When a stop signal comes from the Smart Logger a relay switches in the SM3.</p> <p>The SM3 then sends a signal to the Smart Logger to start measuring, and also activates the relay outputs to stop the machine. The relay in the SM3 is reset via the software when a new measurement is to be made. The SM3 is connected to the Smart Logger by an M12 connection.</p>	
Dimensions	85 x 72 x 49 mm. (wxhxd)		
Weight	0.2 kg		
Application area	Electrical connection providing a stop pulse.		
Supply voltage	Fed from the Smart Logger		
Relay outputs	2 NO, 2 NC, 6A/250 VAC.		
Encoder	1 connection for a pulse sensor		

SM11 Flag unit

Article number	2TLA070300R1100	<p>The Smart Logger is used in conjunction with the SM11 for automatic measurements of the stopping time and stopping distance. The unit is located in a light curtain with the flag parallel to the beam.</p> <p>When the flag is activated, the light beam/light curtain is interrupted, and the machine stops. The SM11 is connected to the Smart Logger by an M12 connection.</p>	
Dimensions	145 x 85 x 37 (wxhxd). Shaft ø3 x 45 mm		
Weight	0.6 kg		
Application area	Light curtain, light beam		
Protection class	IP40		
Batteries	10 rechargeable 1.2 V NiMH batteries. Total 12 V		
Power	Max 1200 mAh (approx. 200 operations).		
Temperature	0 to +45°C.		
Installation	On a table or a standard ¼" camera tripod		
Charger	SM14		

SM5 1250/2500 Linear sensor

Article number	SM5/1250 Linear sensor: 2TLA070300R0400 SM5/2500 Linear sensor: 2TLA070300R0500	The SM5 is an incremental pulse sensor for connection to a Smart Logger. The sensor is protected by a robust enclosure. The sensor and end of the cable are secured to the machine by powerful magnets. The SM5 is connected to the Smart Logger by an M12 connection.	
Dimensions	1250: 106 x 88 x 100 mm (wxhxd) 2500: 114 x 125 x 116 mm (wxhxd)		
Weight	SM5/1250: 1 kg SM5/2500: 1.4 kg		
Application area	Linear movement, e.g. press tools		
Supply voltage	Fed from the Smart Logger		
Max length	1250 or 2500 mm		
Max speed	5 m/s		
Resolution	0.1 mm		

SM7 Rotation sensor

Article number	2TLA070300R0700	The SM7 is an incremental sensor for connection to a Smart Logger. The sensor detects rotational movement via a wheel rolling against a shaft. The stand secures the sensor with the aid of just one knob. The stand itself is secured to the machine by a powerful magnetic foot. The SM7 is connected to the Smart Logger by an M12 connection.	
Dimensions	Sensor size: 46 x 40 x 59 (wxhxd) Stand size: Extended, approx. 400 x 50 x 80 (wxhxd)		
Weight	1.7 kg including stand		
Application area	Rotating motion, e.g. lathes, rollers		
Supply voltage	Fed from the Smart Logger		
Max speed	5 m/s		
Resolution	0.1 mm		
Wheel circumference	125 mm		

SM13 Battery pack

Article number	2TLA070300R2300	SM13 is a battery pack for the Smart Logger, which makes the Smart a completely mobile measuring tool. With the SM13 you don't need to connect the Logger to a wall socket for power, and can easily move it from one machine to another when you are measuring. Since the SM13 battery pack is the same physical size as the SM11 flag unit, it fits snugly into the SM9 carrying case. The charger for the SM13 is called the SM14 and provides a charging time of about 3 hours 15 minutes (2100 mAh). The SM14 also acts as a fast charger for the SM11.	
Dimensions	145 x 85 x 37 mm (LxWxH)		
Weight	0.8 kg		
Protection class	IP40		
Connector	Negative pole at the centre of the charging connector		
Current rating	Maximum 0.9A		
Power	2100 mAh. With normal use lasts about 10-12 hours. (Higher capacity on request.)		
Batteries	20 rechargeable 1.2 V NiMH batteries of size AA (R06). Total 24 V		

SM9 Carrying case

Article number	2TLA070300R0900	The SM9 is a practical carrying case with pockets to suit the various Smart units. Part of the protective foam insert in the lid of the case can be removed to make room for a laptop computer, so that all the equipment required can be carried in a single case.	
Dimensions	535 x 155 x 430 mm (LxWxH)		
Weight	3.5 kg		

Other accessories

Name	Article number	Description
SM6	2TLA070300R0600	AC/DC converter for Smart
SM14	2TLA070300R2400	Charger for flag unit SM11 and battery pack SM13.
USB cable	2TLA070300R1500	USB cable for communication with computer
Extension cables		ABB Jokab Safety's extension cables with 5 conductors ideal for all Smart accessories



Sensors/Switches/Locks

Why should you use sensors/switches? 9/3

Non-contact safety sensor

Eden 9/5

Eden AS-i 9/7

Safety Magnetic Switch - Sense7 9/13

Magnetic lock

Magne 9/15

Process lock

Dalton 9/21

Safety and process lock

Knox 9/27

Safety Interlock Switch

Safety Interlock Switch - MKey5 9/33

Safety Interlock Switch - MKey8 9/35

Safety Interlock Switch - MKey9 9/39

Why should you use sensors/switches?

– to supervise doors and hatches around dangerous machines!

Assurance that a machine stops, when a door or a hatch is opened, can be solved by using different types of switches and sensors, which are monitored with a safety relay or a safety PLC. Switches and sensors are available both as non-contact (dynamic or magnetic) and various types of interlocking devices. Interlocking devices can be used when it is required, via a signal, to lock a gate during processes that cannot be stopped during certain operations. They are also used with machines that have a long stopping time to prevent someone from entering before the machine has stopped.

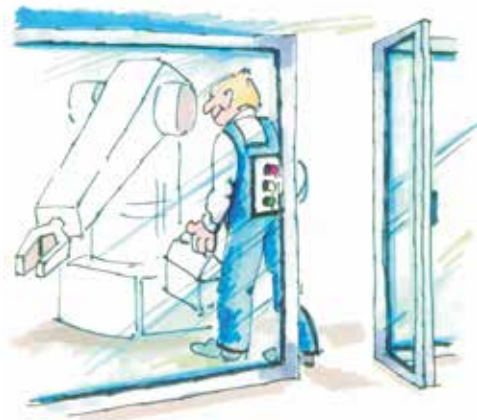

– to ensure that a position is reached!

The sensor monitors that the robot is standing still in a monitored position when someone enters the robot's working area. The robot is then only stopped by the program, not by loss of power. If the robot leaves the position the power will be cut directly. This is used when the robot can not be stopped safely without resolving in restarting problems.

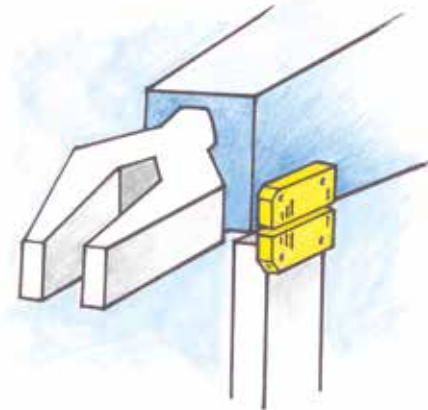

– to manage the safety in harsh environments!

Non-contact dynamic sensors have a long lifetime because they are not physically mechanically operated. They also endure very harsh environments, e.g. cold, heat, high-pressure wash-down which is important in the food industry for example. Because the sensors are small, they are very easy to position and can even be completely concealed in doors and hatches.



Eden – highest safety level and reliability

Our recommendation is to use the Eden sensor because it is the safest and most reliable solution. The Eden sensor is a non-contact switch and has a dynamic function. Also it is possible to connect up to 30 Eden sensors in series and still achieve PL e according to 13849-1.

What requirements should one have on sensors/switches?

The sensor/switch shall be reliable from both the safety and production point of view.

- A person must be able to trust that dangerous movements and functions are safely stopped by the sensors/switches.
- From the production point of view unintentional stops should be avoided.
- Standard EN ISO 13855 now includes requirements for safety distances for interlocked doors without locking function.

Safety level

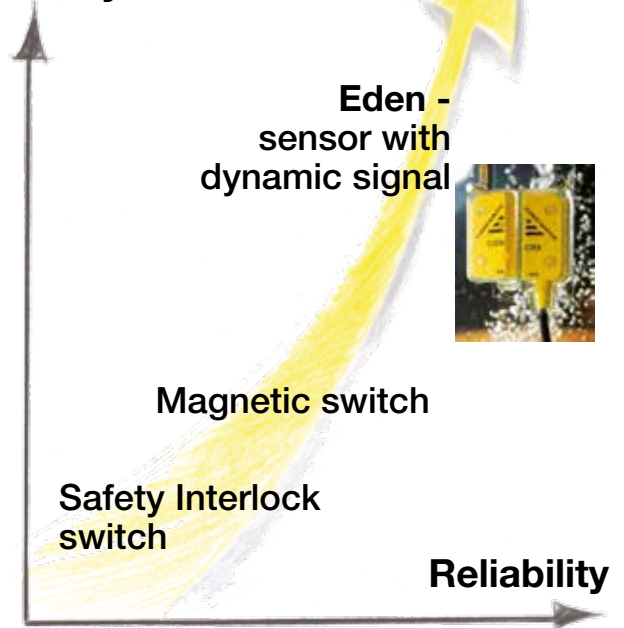

How safe is a sensor/switch?

In order to trust the safety function it is essential to be aware that a safety sensor/switch must be mounted and be used according to the specifications. The certification authorities only test the product according to the appropriate standards and to the specifications from the manufacturer.

Mechanical switches

For mechanical switches, e.g. key operated, this means that a door or a hatch has to be constructed to small tolerances in order for the switch, the key or the mounting brackets to last according to the life time specification from the supplier. The screws holding the parts have to be locked in such a way that they cannot be loosened. In order to prevent material from getting into the slot for the key the environment has to be clean. If a door goes outside the design tolerances from wear, the screws loosen or material comes into the slot, this may lead to the interlocked switch not giving a stop signal when the door is opened. Even two mechanical switches on a door could fail to an unsafe state if the door somehow gets outside the tolerances of the switches. To prevent accidents the mechanical switch normally needs continuous checks of both the switch and the installation.

Non-contact sensors/switches

For non contact sensors the risks associated with mechanical switches (see above) do not exist. If screws, brackets or sensors get loose, it will lead to a stop signal. Therefore only one sensor with dual or dynamic function is needed in order to reach the high-

est safety level. There are two types of non-contact sensors - active and passive. The active sensor, Eden, is constantly communicating via a dynamic signal between the two parts and any failure will directly lead to a stop signal. The passive type, a magnet switch, has two reed contacts which are activated by a coded magnet. Both the passive and the active sensors are checked every time a door is opened. From a safety point of view the active sensor, Eden, is to be preferred because it is checked constantly whereas the passive sensor is only checked when a door opens.

From the reliability point of view a long detection distance with large tolerances and a well defined on and off position is needed. The active sensor, Eden, fulfils these demands. A magnet switch has smaller tolerances and an intermediate position where only one contact opens. A bad installation or vibrations can lead to an unintentional stop if one contact opens and closes again. The supervision of a two channel system is based on both contacts having to be operated in order to permit a new start. In a dynamic safety circuit there is only one pulsed signal and therefore no intermediate position.

Non-contact safety sensor Eden

Approvals:



Application:

- Door and hatches
- Position control
- Sector detection
- Slot detection

Features:

- PL e/Cat. 4 according to EN ISO 13849-1 together with Vital or Pluto
- Non-contact detection, large sensing distance 0 - 15 mm +/- 2 mm
- Up to 30 sensors in series with the highest level of safety PL e
- Versatile mounting, 360° detection
- Protection class IP67/IP69K
- The dynamic signal passes through wood and plastic (not metal)
- Status information with LED on the sensor and in the cable connection,
- Small hysteresis (< 1mm)

A non-contact safety sensor for the highest safety level

Eden - Adam and Eva is a non-contact safety sensor for use on interlocked gates, hatches etc. The safety sensor Eden is built on the principle of a dynamic safety signal that can be generated and interpreted by the control device Vital, or Safety PLC Pluto. The maximum sensing distance between Adam and Eva is 15 mm ± 2 mm.

Up to 30 Edens can be connected in series to Vital and still achieve the same safety level in the safety circuit. It is also possible to connect safety light beams and E-stops in the same safety circuit.

Adam is available with only a M12 connector or with cable lengths up to 20 m (also with M12 connector). For harsh environments there is a special version of Eden cast in Polyurethane; Eden E.

In addition to the safe signal out from Adam, there is also a non-safe status signal (on pin 5) that indicates contact/non-contact between Adam and Eva.

LED indication

The LED on Adam provides a green indication of contact between Adam and Eva, and a red indication indicates a non-contact. A rapid flash indicates that an alignment of the sensor is necessary. If the LED is flashing between red and green the sensor is not receiving a dynamic signal from previous sensor or Vital/Pluto.

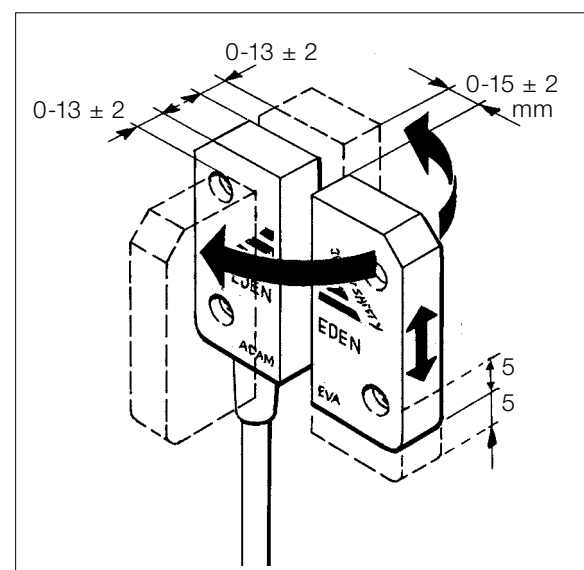

Flexible mounting

Technical data – Eden

Article number	
Eva	2TLA020046R0000
Eva E	2TLA020046R0600
Adam M12 (with 4 DA1)	2TLA020051R0000
Adam 3 m (with 4 DA1)	2TLA020051R0200
Adam 10 m (with 4 DA1)	2TLA020051R0400
Adam 20 m with (4 DA1)	2TLA020051R0500
Adam E 10 m	2TLA020051R0600
Adam E 0.5 M12	2TLA020051R0700
Adam E 20 m	2TLA020051R0800
Level of safety	
IEC/EN 61508-1...7	SIL3
EN 62061	SIL3
EN ISO 13849-1	PL e/Cat. 4
PFH_D	4.50×10 ⁻⁹
Colour	Yellow and black
Weight	Eva: 26 g Eva E: 36 g Adam M12: 30 g Adam 3 m: 220 g incl. cable Adam 10 m: 650 g incl. cable Adam E10 m: 660 g incl. cable Adam E 0,5 m + M12: 100 g incl. cable
Power supply	24 VDC +15%-25%
Power consumption	Adam: without info output 45 mA with info output max 55 mA
Max cable length	see Vital technical data
Ambient temperature	
Eden	-25°C ... +70°C (operation) -25°C ... +70°C (stock)
Eden E	-40°C ... +70°C (operation) -25°C ... +70°C (stock)
Protection class	
Eden	IP67
Eden E	IP67 and IP69K
Mounting	
Installation Eden	M4 screw, e.g. safety screw 2TLA020053R4200. Max. torque 2 Nm. Screw to be locked with Loctite or similar.
Installation Eden E	M4 screw, e.g. safety screw 2TLA020053R4300. Max. torque 0.8 Nm. Screw to be locked with Loctite or similar.
Detection distance max	
Adam/Eva 15 ± 2 mm	Flash 2 mm before red position.
Adam E/Eva E 12 ± 2 mm	Flash 2 mm before red position.
Hysteresis approx. 1 mm	
Metal may have influence on detection distance. This can be prevented by protection plates, DA1.	
Minimum distance to metal when there is metal on one or more sides.	
Adam/Eva	One More 0 mm 2.5 mm
Adam E/Eva E	0 mm 0 mm
Minimum distance between Eden pairs	50 mm
Mechanical life	>10 ⁷ cycles

Material	Eden: Macromelt Eden E: Polyurethane (PU)
Chemical resistance	
Macromelt:	Cutting oils, vegetable and animal oils, hydrogen peroxide, diluted acids and bases: good Alcohol and strong acids: not recommended
PU (EdenE):	Cutting oils, vegetable and animal oils, hydrogen peroxide, diluted acids and bases, alcohols: good Strong oxidating acids: not recommended
LED on Adam	
Green:	Eva within range, safety circuit closed (door closed)
Flashing:	Eva within range, earlier safety circuit open (door closed)
Red:	Eva out of range, safety circuit open (door open)
Rapid flashing:	Eva is within 2 mm from maximum sensing distance (door closed)
Cable	3, 10 or 20 m, ø 5.7mm, black, PVC 5 x 0.34 mm ² + screen, UL 2464
Connector	M12: 5-pin male contact
Connections	
Brown (1)	+24 VDC
White (2)	Dynamic signal in
Blue (3)	0 VDC
Black (4)	Dynamic signal out
Grey (5)	Info output, see below
24 VDC when LED is green or flashing (tolerance -2 VDC), 10 mA max 0 VDC when LED is red. (tolerance +2 VDC)	
Warning: Incorrect connection may cause permanent damage to Adam devices.	
Conformity	2006/42/EG EN ISO 12100 1/2, EN 60204-1, EN ISO 13849-1, EN 1088

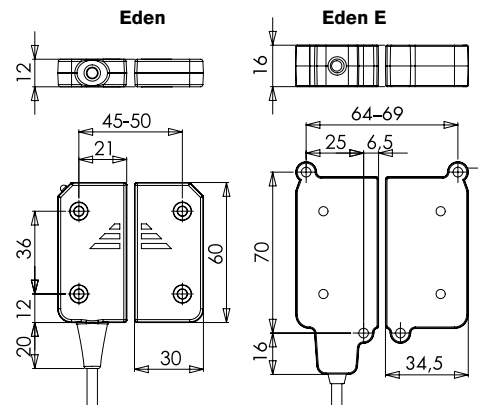

Non-contact safety sensor with integrated AS-i node

Eden AS-i



A non-contact safety sensor for the highest safety level

Eden AS-i is a non-contact safety sensor for use on inter-locked gates, hatches etc. Eden AS-i consists of two complementary parts called Adam and Eva. The sensor is only activated if the gate or hatch is closed e.g. when Adam and Eva are within sensing distance. Eden AS-i is constantly communicating between the two parts and any failure will directly lead to a stop signal.

A non-contact safety sensor for AS-i

Eden AS-i has an integrated AS-i node and is connected via an M12 connection directly to the AS-i cable.

Eden AS-i has a protective encapsulation that enables Eden AS-i to be used in harsh environments. Each Eden AS-i is individually coded which makes it secure against manipulation.

The advantage of safety within AS-i is that it is very easy to install since connection of the safety devices is just to the buss cable. The function of the safety devices is determined by the software program in the safety monitor/master. Each safety device (node) has its own address and a unique safety code.

It is simple to add, move and disconnect safety devices on the AS-i cable as well as to extend the AS-i cable. Traditional safety systems require new cable running from the electrical cabinet for each new protection. Connection with Eden AS-i is simple as all units are connected to the same cable.

Approvals:



Application:

- Door and hatches
- Position control
- Sector detection
- Slot detection

Features:

- PL e/Cat. 4 according to EN ISO 13849-1
- Non contact detection 0-15 mm +/- 2 mm
- Versatile mounting, 360 degrees
- Protection class IP69K
- The signal passes through wood and plastic (not metal)
- Status information LED
- Small hysteresis (1-2 mm)
- Individually coded

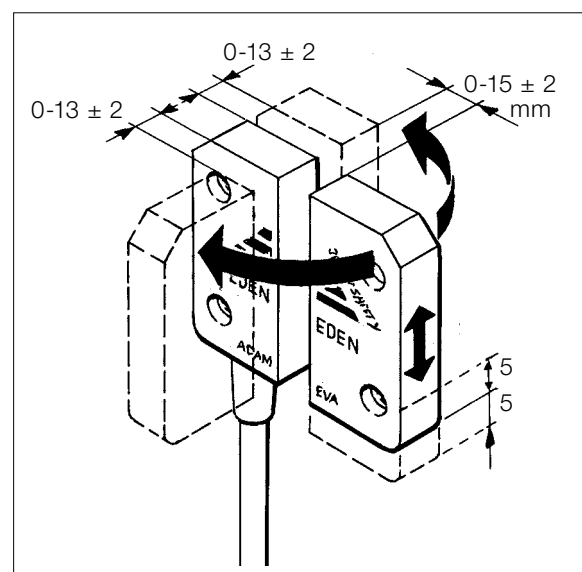

Flexible mounting

Connection to the AS-i bus

AS-i makes safety easy

Installation is easy as all units are connected to the same yellow AS-i cable/bus. This thereby minimises the risk of faulty connection. Each safety node has its own address and a unique safety code.

Eden AS-i has a built-in AS-i safety node and is supplied with 30 VDC from the AS-i bus.

Connection to the AS-i bus is through a flat cable connector to M12, making it possible to quickly and easily connect Eden AS-i to the AS-i cable.

Our Pluto is the most flexible AS-i Safety Controller on the market. Pluto can be used as Safety Master, Monitor or I/O and can control and monitor the safety of a machine at the same time.



Manual Status LED indication

LED	Setting (hex)	Setting (binary)	Description
LED on Adam AS-i	1	0,0,0,1	LED lights red
	3	0,0,1,0	LED lights green
	All other	All other	LED OFF

Automatic Status LED indication

LED	Indication	Description
LED on Adam AS-i	Green	Eva within sensing distance of Adam
	Green and/or Red (fast flash) or both lights at the same time	Eva within ~2 mm of maximum sensing distance
	Red	Eva not within sensing distance of Adam

Status LED indication (independent of manual or automatic control)

LED	Indication	Description
LED on Adam AS-i	Green-Red (flash)	No contact with AS-i master
	Red (flash)	Internal fault. Power cycle, replace if still present

AS-i LED and Fault LED in combination

AS-i (green)	Fault (red)	Description
OFF	OFF	AS-i power missing
ON	OFF	Normal operation
ON	ON	No data exchange with master
Flash	ON	No data exchange because address = 0

Technical data – Eden AS-i

Article number	Adam AS-i with 4 DA2 B Eva AS-i	2TLA020051R6000 2TLA020051R8000
AS-i data	AS-i profile	S-7.B.E
Slave address at delivery	0	
Addressing via	M12-connector	
Response time over AS-i bus	10 ms	
Safety data - annual usage	PFH _d	6.0*10e-10
Proof test interval (life)	20 years	
Power supply, operating voltages	30 VDC, AS-i bus. Tolerance	26.5-31.6 VDC
Switching distance (target to target)	15 +/- 2 mm	
Total current consumption	65 mA	
Assured release distance (Sar)	45 mm	
Assured operating distance (Sao)	7.5 mm	
Enclosure protection	IP67 and IP69K	
Cable type	M12-connector 4-pole male (only pin1 and pin3 used)	
Ambient temperature	Storage: -40...+85°C Operation: -25...+55°C	
Weight	~150 g	
Material	Housing: Polybutylene terephthalate (PBT) Moulding: Epoxy	
Colour	Yellow, black text	
Mounting bolts	SM4	
EN ISO13849-1	Up to PL e/Cat. 4	
EN62061	Up to SIL3	
IEC/EN 61508-1...7	SIL3, PFH _d : 9.11x 10 ⁻¹⁰	
Approved standards	European Machinery Directive 2006/42/EG EN ISO 12100-1:2003+A1:2009, EN ISO 12100-2:2003+A1:2009, EN ISO 13849-1:2008, EN 62061:2005, EN 60204-1:2006+A1:2009, EN 60664-1:2007, EN 61000-6-2:2005, EN 61000-6-4:2007, EN 60947-5-1:2003+A1:2009, EN 1088+A2:2008	

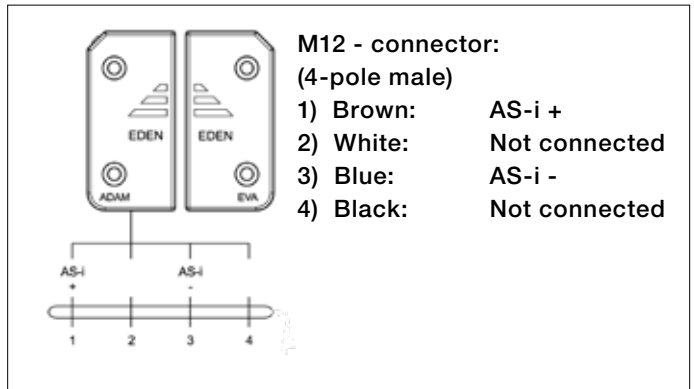

Eden AS-i electrical connections

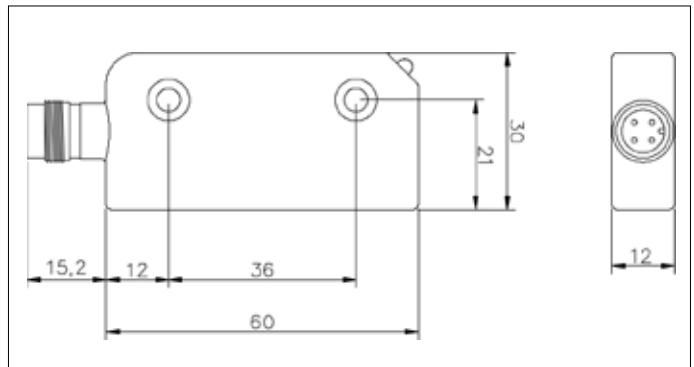

Dimensions

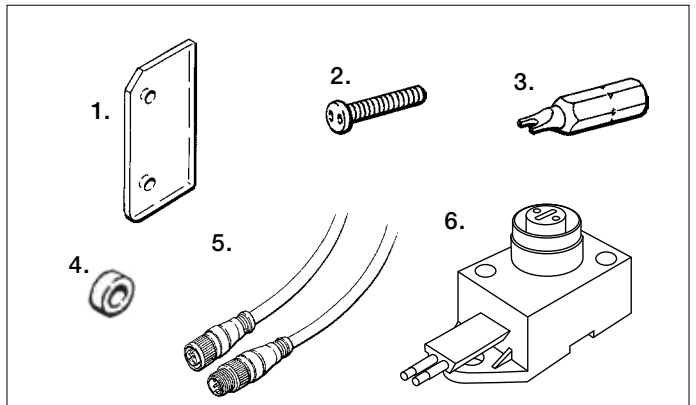

Accessories:

1. Protection plate DA1: 2TLA020053R0000
2. Safety screws, SM4 x 20: 2TLA020053R4200
3. SBITS: 2TLA020053R5000
4. DA2B, Mounting spacer: 2TLA020053R0300
5. M12-C112 1 m cable, 5-pole, 0.34 mm², M12 female + male: 2TLA020056R2000,
M12-C312 3 m cable, 5-pole, 0.34 mm², M12 female + male: 2TLA020056R2100
6. AS-i T-connector with M12, Flat cable connector to M12: 2TLA020073R0000

Eden and Eden AS-i

Application examples

Eden to detect position

Adam and Eva can be used to ensure that a safe position is kept/reached. The safety sensor has contact if they are within 15 mm from each other.

Eden is used for sector detection

Additional Eden sensor(s) can be mounted on a machine to detect working place.

Eden can communicate through wood and plastic

Wood, plastic and other non-metallic materials between Adam and Eva let the communication signal pass.

Eden can be hidden in doors and hatches

Because of the small size, Eden can easily be hidden in frames or guards.

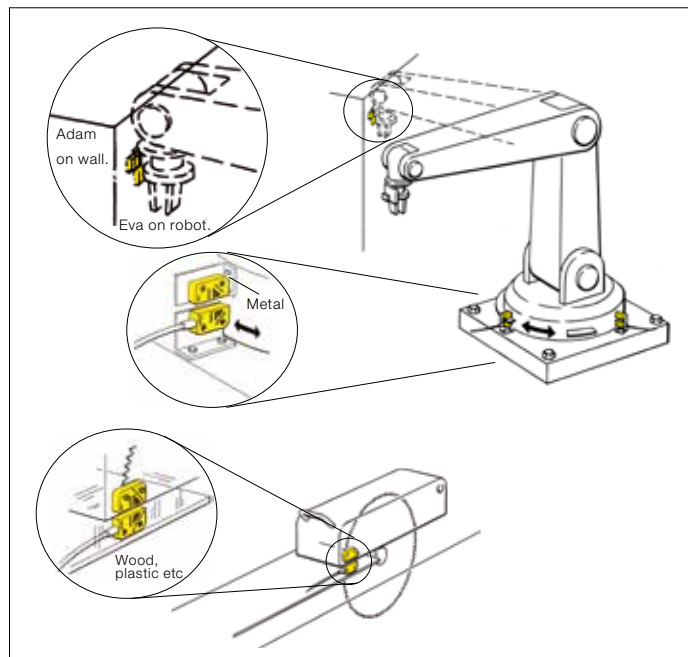

Mounting – Eden

Installation and maintenance for Eden

Eva can be turned in a number of different ways relative Adam. Depending on the cable connector used to connect Eden, different protection plates can be necessary in order to avoid damage to Adam. The protection plates (DA1) supplied with Adam M12-models connector are recommended for this, see figure below. Also, the mounting spacers supplied must be used in order to physically protect Eden from damage.

- Mounting with one protection plate (DA1) for Adam M12 using prewired moulded M12 connector. For M12 connection, a straight contact is recommended.
- Mounting with two protection plates (DA1) for Adam M12 using M12 connector with glanded cable.
- Wrong mounting without protection plate may cause permanent damage to sensor.

Sensing distance between Adam and Eva: 0-15 mm +/- 2 mm
 Minimum distance between two Eden pairs: 100 mm

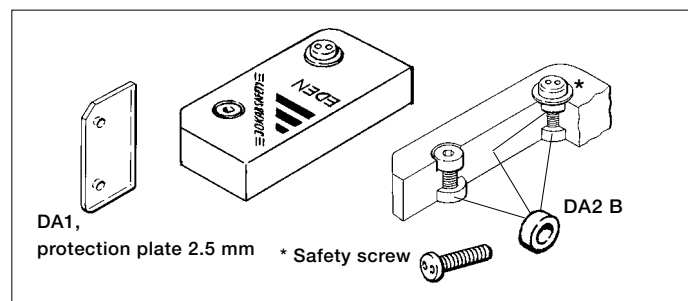
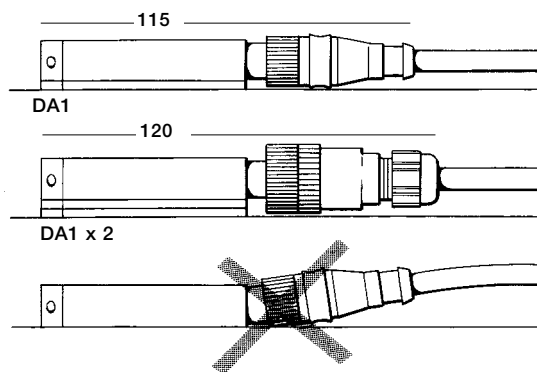

Adam M12 Dimensions

Adam M12

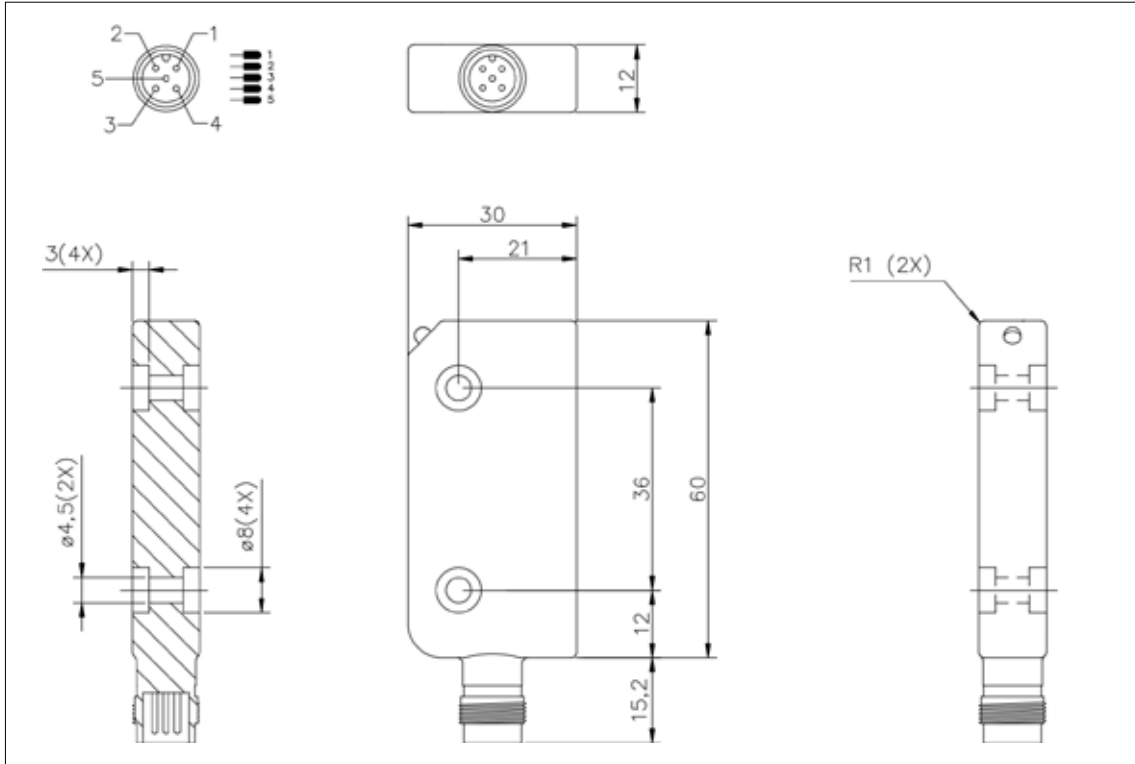

9

Adam M12 AS-i

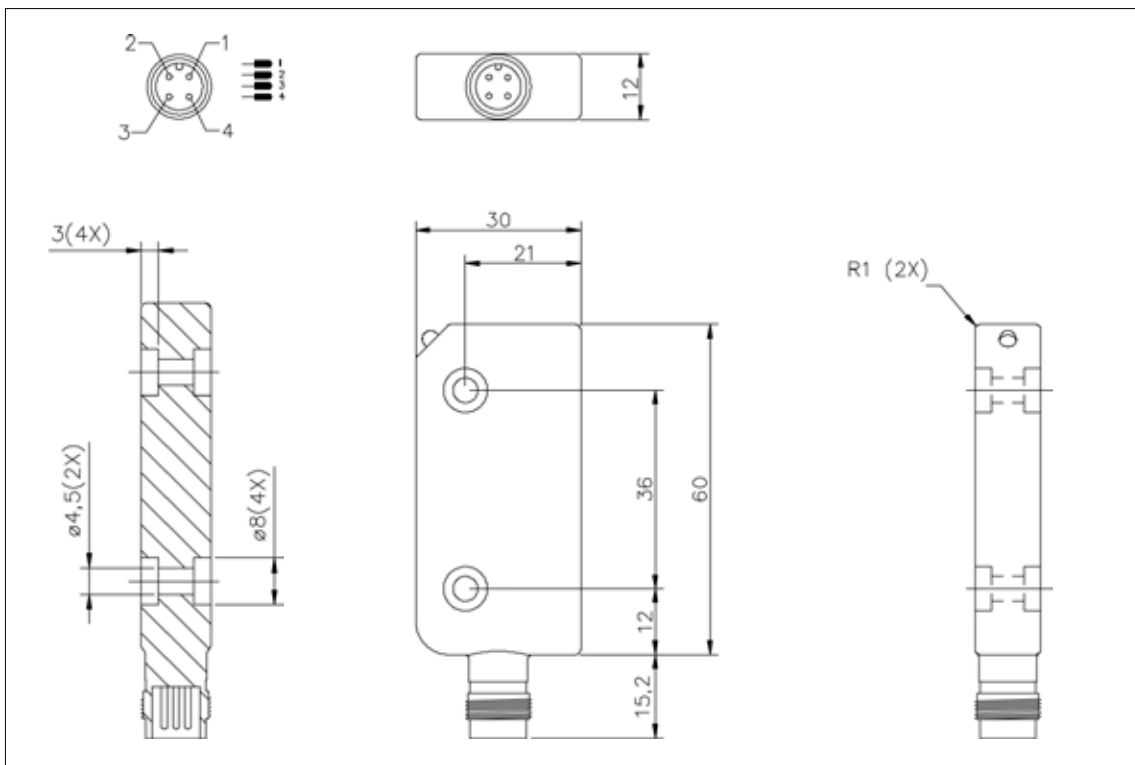

Eden

Connection examples

Connection of Eden to Pluto

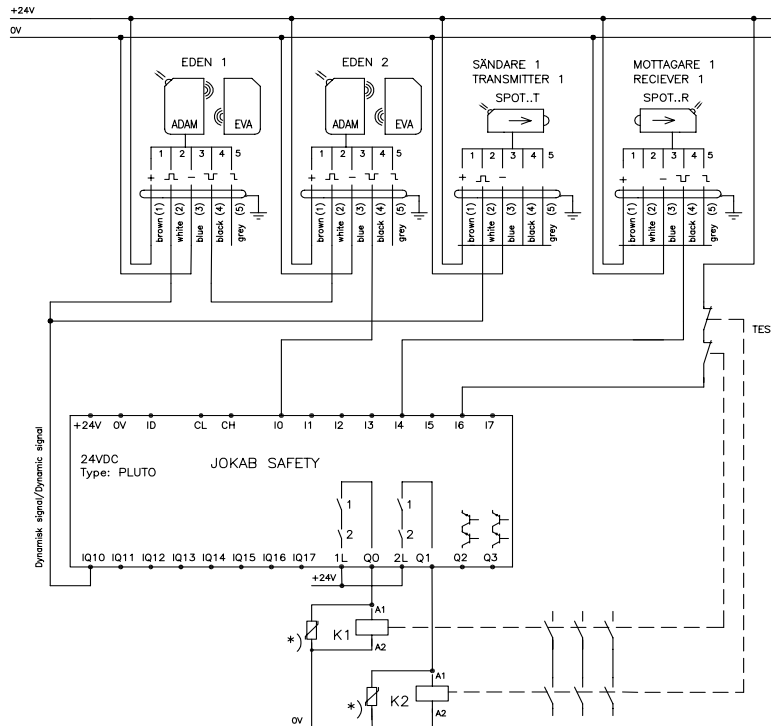

*)OBS: Använd alltid transientkydd t.ex. VDR!
 *)NOTE: Always use transient suppressors, e.g. VDR's!

Connection of Eden to Vital 1

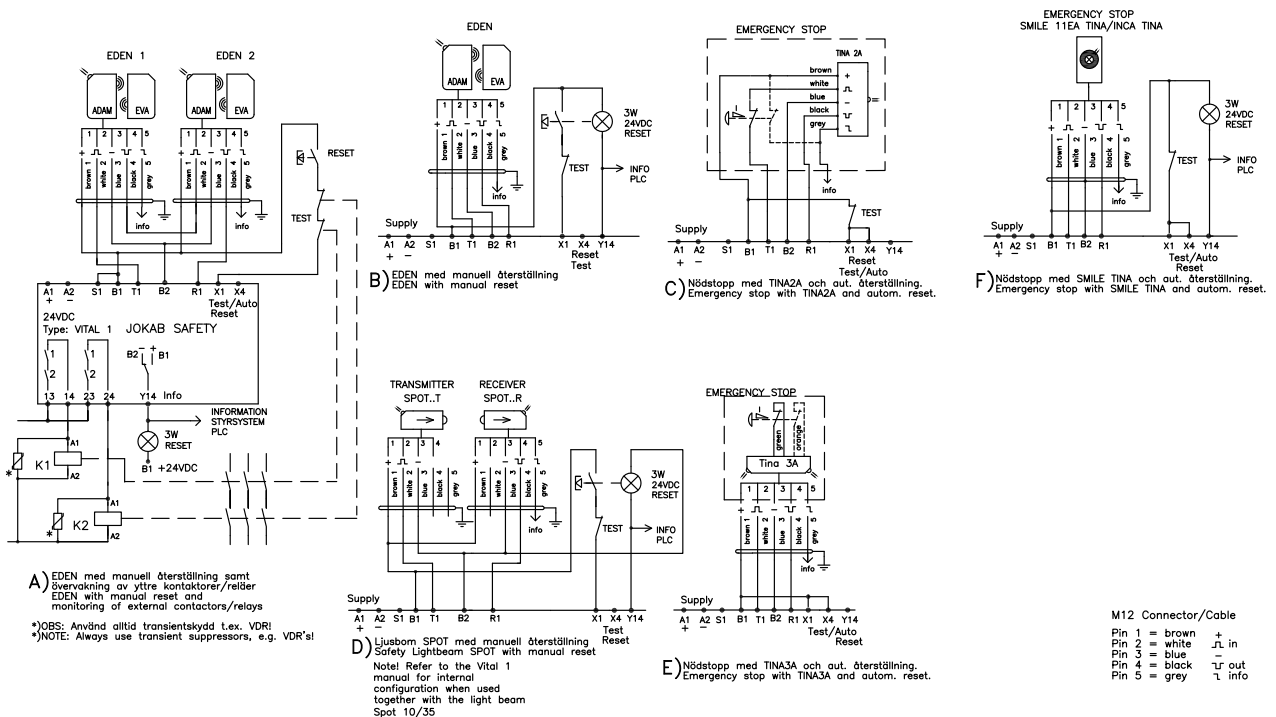

Safety Magnetic Switch Sense7



Approvals:



Application:

- Gates
- Hatches
- Position control

Features:

- Small size
- Up to IP69K
- LED
- 2NC + 1NO
- Solid State outputs

Switch operational description

The coded non-contact switches Sense7 are designed to interlock hinged, sliding or removable guard doors. Its design makes it advantageous to operate in environments that require the highest level of safety.

The magnetic switch is small in size which makes it easy to position and hide on gates and hatches. Sense7 is resistant to both dirt and water, and has no dust collecting cavities, which make it useful in environments where hygiene is paramount. The magnetic switch has a long working life since no mechanical contact is necessary for operation. Sensing distance of Sense7 is 14 mm and it has a high tolerance to misalignment. Actuator is always delivered with the non-contact switch.

Material

The Sense7 switch is available in UL approved polyester and in stainless steel 316. The stainless steel has a mirror polished finished (Ra4) suitable for CIP cleaning - food splash zones according to EHEDG guidelines.

Protection from unauthorised or incidental access

To avoid unauthorised operation of the Sense7 switch, it is only possible to actuate the coded magnetic switch with the coded magnet. Other magnets, screwdrivers and tools have no effect on the switch contacts.

Safety level

The Sense7 has two closing and one opening contact. Two contacts have to be monitored to achieve the highest level of safety regulations, PL e/Cat. 4 according to EN ISO13849-1 together with safety relay or Safety Pluto PLC.

Regulations and Standards

The Sense7 is designed and approved in accordance to relevant standards. Examples of relevant standards are EN1088, IEC/EN 60947-5-3, EN 60204-1, EN ISO 13849-1, EN 62061 and UL 508.



Sensing distance 14 mm



Quick connected version fitted with 250 mm cable and M12.

NOTE! Sense7 versions have 2NC and 1NO circuits. For all Sense7 switches the NC circuits are closed when the guard is closed and the actuator present.

Technical data – Sense7 series

Article number	
Plastic	
Sense7 - 2 m cable	2TLA050056R4100
Sense7 - 5 m cable	2TLA050056R5100
Sense7 - 10 m cable	2TLA050056R6100
Sense7 - 250 mm cable with M12	2TLA050056R2100
Stainless steel	
Sense7Z - 2 m cable	2TLA050056R4120
Sense7Z - 5 m cable	2TLA050056R5120
Sense7Z - 10 m cable	2TLA050056R6120
Sense7Z - 250 mm cable with M12	2TLA050056R2120
Level of Safety	
EN ISO 13849-1	Up to PL e/Cat. 4 depending upon system architecture
EN 62061	Up to SIL3 depending upon system architecture
Safety data	
PFH _D	2.52 x 10 ⁻⁸
Switching reliability	3.3 x 10 ⁶ operations at 100mA load 47 years
Proof test interval (life)	470 years (8 cycles per hour/24 hours per day/365 days)
MTTF _d	hours per day/365 days)
Safety channel 1NC	24 VDC 0.2 A max. rating
Safety channel 2NC	24 VDC 0.2 A max. rating
Safety channel 3NO	24 VDC 0.2 A max. rating
Power supply	24 VDC ±10%
Minimum switched current	10 VDC 1mA
Dielectric withstand	250 VAC
Insulation resistance	100 MOhm
Recommended setting gap	5 mm
Switching distance (target to target)	Sao 10 mm close (on) Sar 20 mm open (off)
Tolerance to misalignment	5 mm in any direction from 5 mm setting gap
Switching frequency	1.0 Hz maximum
Approach speed	200 mm/m to 1000 mm/s
Vibration resistance	IEC 68-2-6, 10-55 Hz 1 mm
Shock resistance	IEC 68-2-27, 11 ms, 30 g
Enclosure protection	IP67 and IP69K
Cable type	PVC 8 core 6 mm O.D
Operating temperature	
Sense7	-25°C to +80°C
Sense7Z	-25°C to +105°C
Material	
Sense7	UL approved polyester
Sense7Z	Stainless steel 316
Colour	Red or stainless steel
Mounting position	Any
Mounting bolts (Tightening torque)	2 x M4 (1.0 Nm)

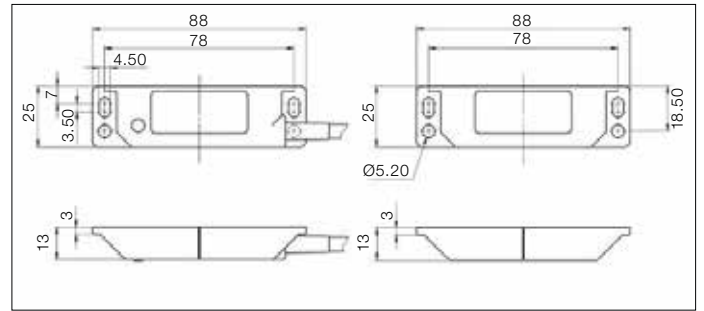

Dimension Sense7

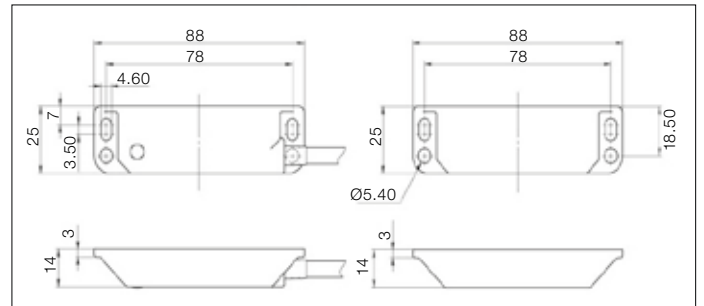

Dimension Sense7Z

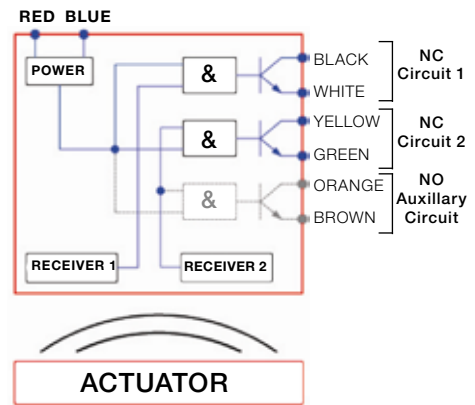

Electrical connection

M12 8pol	Sense7 - 250 mm cable with M12 (Pin view from switch)	Colours
1	1	White
2	2	Red
3	3	Blue
4	4	Yellow
5	5	Brown
6	6	Green
7	7	Black
8	8	Orange

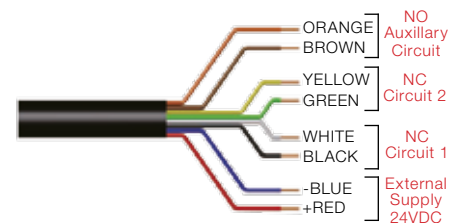

Cable configuration

Magnetic lock Magne



Magnetic lock with indication

Magne is an electro-magnetic lock designed for industrial applications and that can withstand harsh environments. As it is designed with no moving parts, it is durable and long-lasting. The unit is intended for use in preventing unnecessary process stoppages, i.e. it is not a safety lock. Magne, with its electro-magnet, keeps a door locked with a holding force up to 1500 N and magnetic material does not attach to the magnetic surface when the power is off.

Use of M12 connectors makes it easy to connect several Magne units and Eden sensors in series enabling control and monitoring by either a Pluto safety PLC or a Vital safety controller. Via the connection cable it is also possible to obtain an indication signal informing if the Magne unit is locked or not.

Accessories:

- Mounting kit for conventional door, with fitting and screws for assembly on ABB Jokab Safety Quick-Guard fencing system (5-15 mm door gap)
- Plastic handle
- Handle profile for mounting on a hinged door with ABB Jokab Safety's Quick-Guard fencing system (5-15 mm door gap).

Approvals:



Application:

- Electrical locking of doors and hatches for production applications that are sensitive to unintentional/unnecessary interruptions.
- For safety supervision the Magne 2 has an integrated Eden.

Features:

- No moving parts
- Strong Magnetic holding force: 1500N
- Can withstand and operate in harsh environments
- Locked/unlocked indication
- Possible to connect in series with Eden sensors
- No current peaks on activation
- Magne 2 in combination with a handle profile provides a complete door solution



Magne is easy to install, adjust and dismantle in and out of the T-slot of the Quick-Guard fencing system.

Magne

Models and accessories



Magne 1A with installation kit JSM D21B and JSM D27.



Magne 2A with installation kit JSM D21B, JSM D24 and JSM D27.



JSM D28 handle profile which cover Magne completely when the door is closed.



Magne 2A with installation kit JSM D23.

Models and ordering data

Magne 1A v2 1500N	2TLA042022R2100	Electro-magnet with 5-pole M12-contact. Anchor plate. Cell rubber.
Magne 1B v2 1500N	2TLA042022R2200	Electro-magnet with 5-pole M12-contact. Anchor plate with permanent magnet. Cell rubber.
Magne 2A v2 Eden incl. EVA, 8-pol M12	2TLA042022R1600	Magnetic lock with indication. Electro-magnet with 8-pole M12-contact. Anchor plate. Cell rubber. Adam (built-in) + Eva (free) door position sensor.
Magne 2B v2 Eden incl. EVA, 8-pol M12	2TLA042022R1800	Magnetic lock with indication. Electro-magnet with 8-pole M12-contact. Anchor plate with permanent magnet. Cell rubber. Adam (built-in) + Eva (free) door position sensor.
Magne 2Ax v2 Eden incl. EVA, 5-pol M12	2TLA042022R1700	Magnetic lock with indication. Electro-magnet with 5-pole M12-contact. Anchor plate. Cell rubber. Adam (built-in) + Eva (free) door position sensor.
Magne 2Bx v2 Eden incl. EVA, 5-pol M12	2TLA042022R1900	Magnetic lock with indication. Electro-magnet with 5-pole M12-contact. Anchor plate with permanent magnet. Cell rubber. Adam (built-in) + Eva (free) door position sensor.
JSM D28	2TLA042023R0100	Aluminum profile used as both door handle and mounting kit for Magne. Completely covers Magne unit when the door is closed.
JSM D21B	2TLA042023R0500	Mounting kit for Magne. For conventional door (5-15 mm door gap). Fits all Magne. Note: When used with Magne 2A/B, -2Ax/Bx a mounting kit for Eva is also required (JSM D24).
JSM D23	2TLA042023R0200	Mounting kit for Magne. For sliding door. Fits all Magne.
JSM D24	2TLA042023R0300	Mounting kit for Eva. For conventional door.
JSM D27	2TLA042023R1000	Handle/screw for JSM D21 Magne installation kit.
Magne cellular rubber	2TLA042023R3600	Spare part. Cellular rubber t=10 mm
Magne Anchor plate 32A	2TLA042023R1300	Spare part. Anchor plate A (without permanent magnet). Width 32 mm. Included with Magne 1/2
Magne Anchor plate 34A	2TLA042022R2300	Spare part. Anchor plate A (without permanent magnet). Width 34 mm.
Magne Anchor plate 32B	2TLA042023R0400	Spare part. Anchor plate B (with permanent magnet). Width 32 mm. Included with Magne 1/2
Magne Anchor plate 34B	2TLA042022R2400	Spare part. Anchor plate B (with permanent magnet). Width 34 mm.

Technical data – Magne

Level of safety	For interlocking switch Eden. Not valid for locking function. IEC/EN 61508-1...7 EN 62061 EN ISO 13849-1	SIL3 SIL3 PL e/Cat. 4
PFH _b		4.50×10 ⁻⁹
Power supply		Magnet: 24 VDC +/- 15% Eden: 17–27 VDC, ripple max 10%
Power consumption		Magnet: 7 W (300 mA at 24VDC) Eden: 45–55 mA (see data for Eden)
Operating temp. range		-20°C to +50°C
Protection class		IP65
Weight		Magne 1: 610 g, Magne 2: 700 g, Anchor 32A/B: 290 g, Anchor 34A/B: 308 g
Material		Anchor plate and magnet: steel Housing: Aluminium Potting: PUR, epoxy
Holding force		24 VDC: Min 1500 N 0 VDC: 0 N (Magne 1A/2A/2Ax) 0 VDC: 30 N (Magne 1B/2B/2Bx)
Contacts		Reed sensor (not safe)
Switch current max		100 mA
Mechanical life		>10 ⁷ switch operations
Connector		M12 5-pole male connector (Magne 1A/B, 2Ax/Bx) M12 8-pole male connector (Magne 2A/B)
Connections		Magne 1A/B: (1) Brown: Locking, +24 VDC (2) White: Sensor supply (3) Blue: 0 VDC (4) Black: NO-contact (5) Grey: NC-contact Magne 2A/B: (1) White: Dynamic signal input (2) Brown: +24V DC (3) Green: Locking, +24V DC (4) Yellow: Locking, 0V DC (5) Grey: Info closed (max 10 mA) (6) Pink: Dynamic signal output (7) Blue: 0V DC (8) Red: Info locked (max 100 mA) Magne 2Ax/Bx: (1) Brown: +24 VDC (2) White: Dynamic signal input (3) Blue: 0 VDC (4) Black: Dynamic signal output (5) Grey: Locking
Conformity		EN ISO 12100-1:2010, EN ISO 13849-1:2008, EN ISO 13849-2:2008, EN 62061:2005, EN 60204-1:2006+A1:2009, EN 60664-1:2007, EN 61000-6-2:2005, EN 61000-6-4:2007, EN 60947-5-1:2004, EN 1088+A2:2008

Magne Dimensions

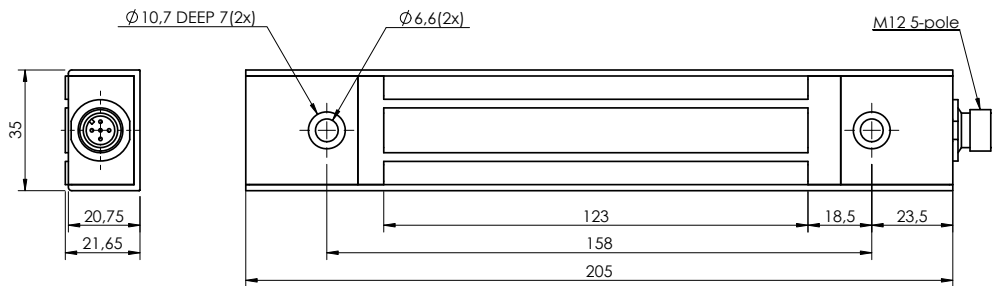

Dimensions Magne 1A/B

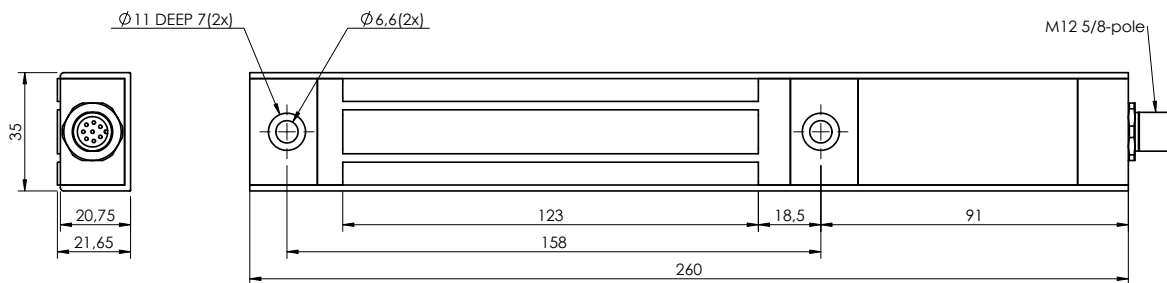

Dimensions Magne 2A/B, -2Ax/Bx

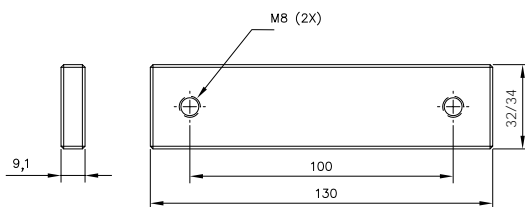

Dimensions Anchor plate 32A/34 (without permanent magnet)

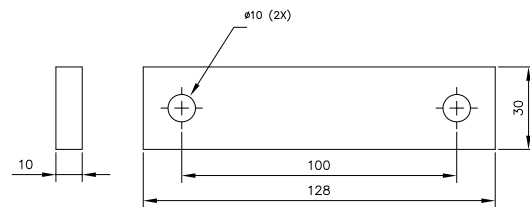

Dimensions - cellular rubber

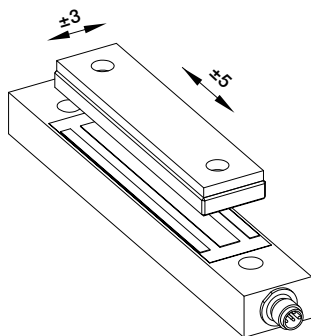

Installation tolerance (general)

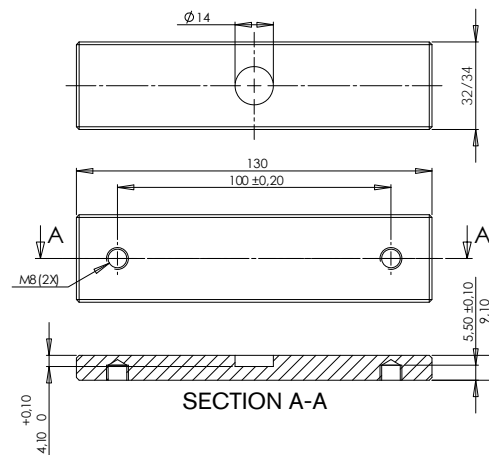

Dimensions Anchor plate 32B/34B (with permanent magnet)

NOTE!
All dimensions are in mm

Magne

Connection examples

Holding force - Magne 1 and 2

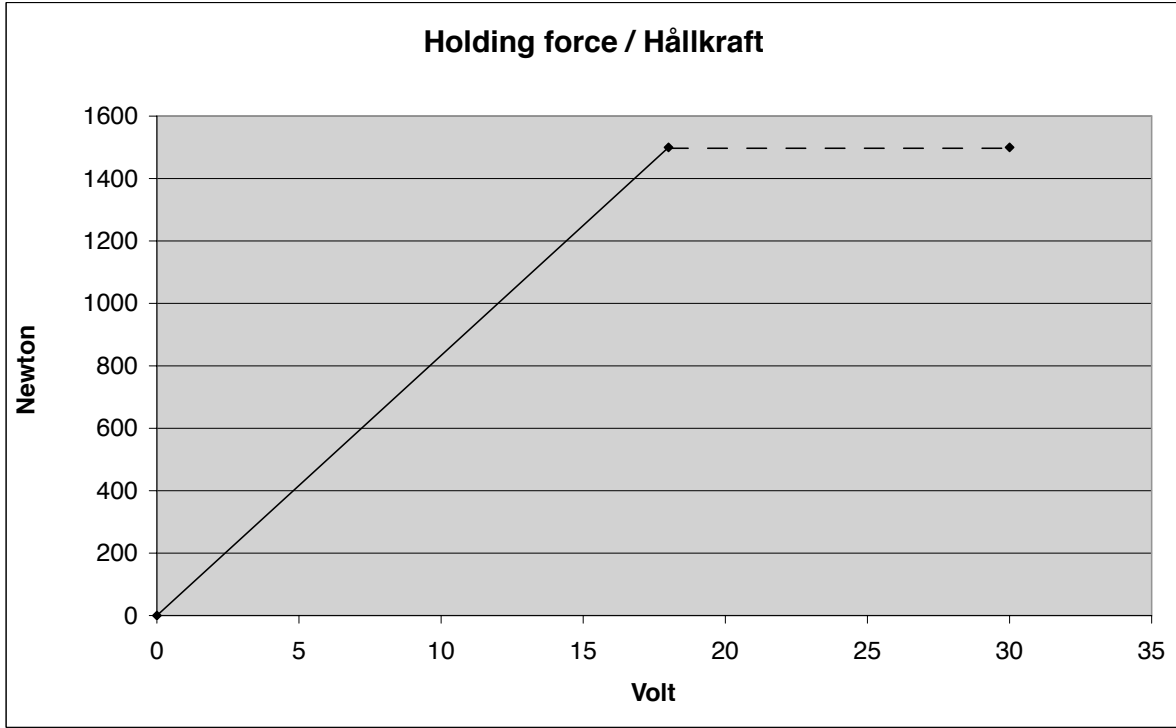

9

Connection example - Magne 1 and 2

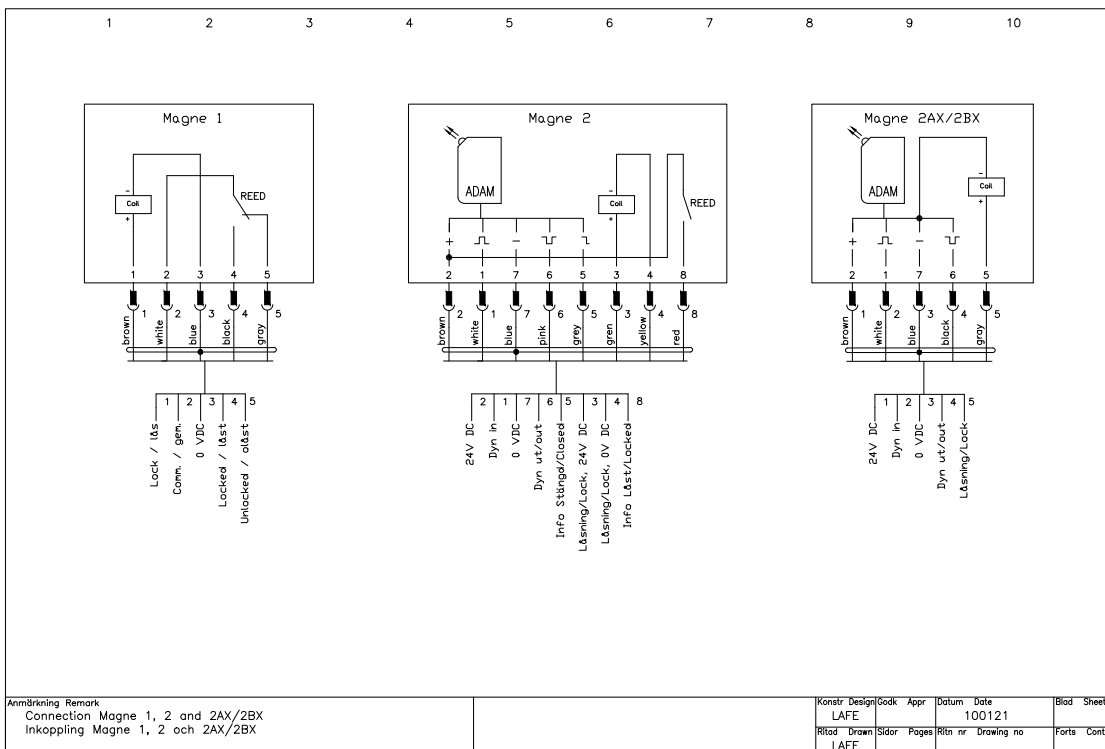

Magne

Connection examples

Connection example - Magne 1 in series

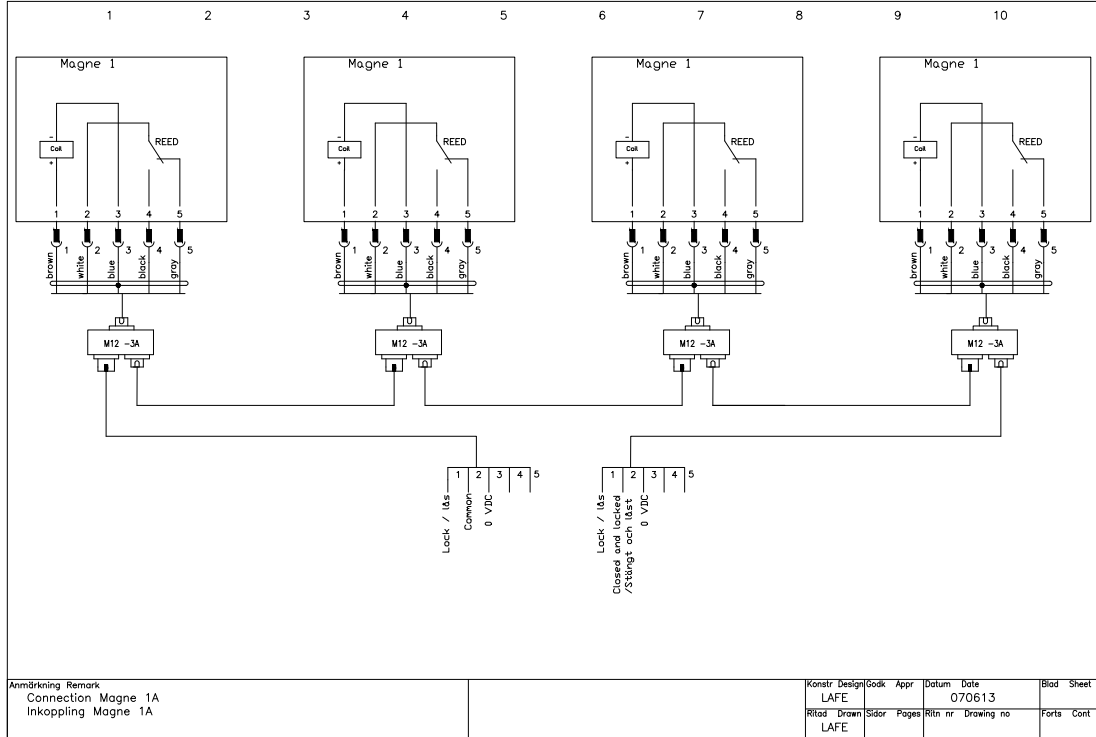

Connection example - Magne 2 in series

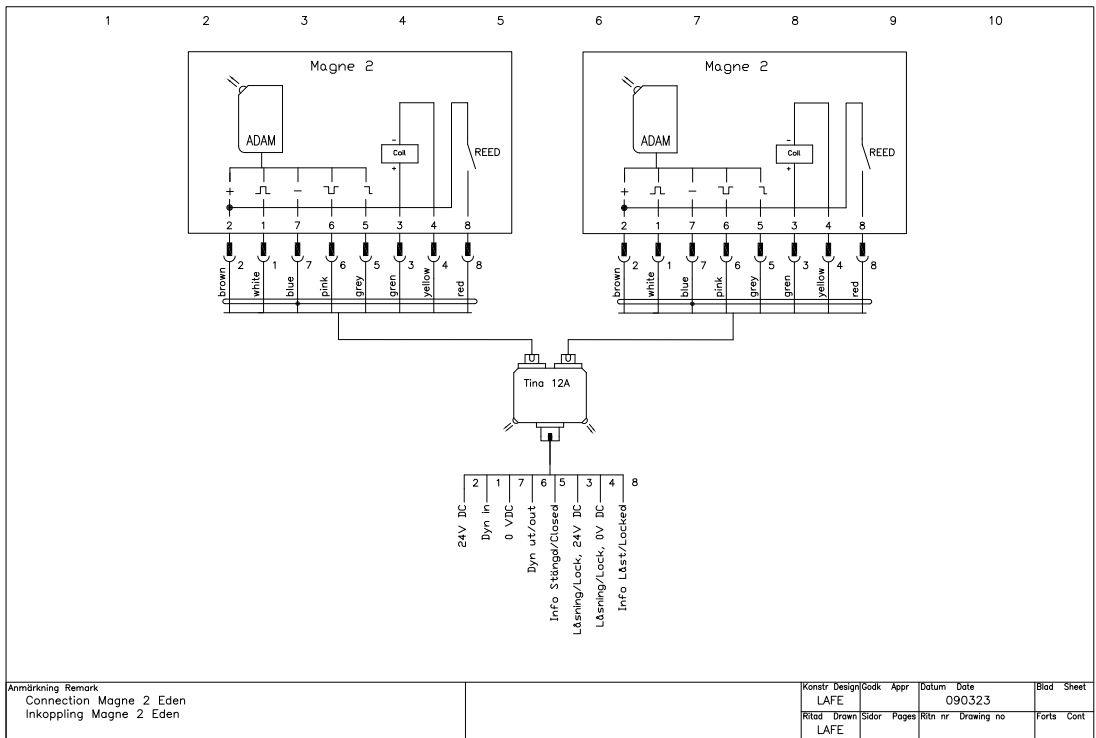

Process lock Dalton



Use:

- Door and hatches

Features:

- Small and robust
- Integrated with Eden
- High enclosure classification IP67
- Withstands harsh environments
- Low current consumption
- Status information with LED on the lock housing and in the cable connection.

Dalton – the intelligent process lock

Dalton is a locking unit that is intended for use in preventing unnecessary process stoppages, i.e. it is not a safety lock. It can be used either as a free-standing lock or integrated with Eden as a safety sensor. In the unlocked state the door is held closed by a ball catch and in locked state the balls are mechanically blocked so the lock tongue can not be pulled out. If necessary, the holding force of the ball catch can be adjusted. The device only allows to lock when the ball latch is centred around the lock tongue, and when Eva is with Adam (depending on version). When an input is supplied with voltage, the ball catch is locked.

Dalton is easily connected with an M12 connector. The Tina junction block can be used for distribution of both the safety and locking functions. The Dalton status is indicated by LEDs and can also be read by a PLC via the information output.

Dalton has a modular structure

The Dalton process lock has a modular structure and can be combined in different ways depending on position, installation and function. You choose the lock housing, lock tongue and fixing plate yourself to create a complete Dalton.

Installation

Dalton offers many different installation possibilities as the lock tongue may enter the ball catch from three directions. In order to ensure that Dalton works without any problems, the ball catch must be resting, i.e. the balls not pressed in by the lock tongue when the door is in closed position. Dalton's brackets are therefore made to ensure easy adjustment of the lock tongue and ball latch positions.

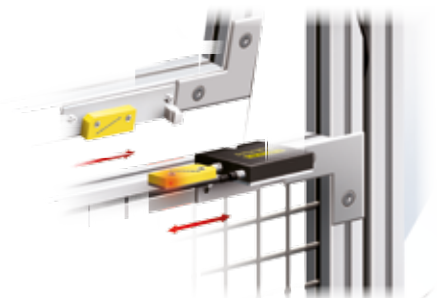

Dalton is easy to install, adjust and dismantle in the Quick-Guard fence system's T-slots.

Dalton

Modular structure

1. Choose Dalton lock housing according to your preferences:

- Dalton M11/M31 If you only need to be able to lock your door/hatch (8-pin/5-pin M12)
- Dalton M12 If you want to lock your door/hatch and also have the interlocking switch Eden installed with one cable, common for both Dalton and Eden.
- Dalton L00 If you only need to use Dalton to keep the door fixed and closed



Dalton M11

with 8-pin male contact

Dalton M12

with 8-pin male contact, 5 pin female contact for Adam

Dalton M31

with 5-pin male contact

Dalton L00

as ball latch, no electrical functions.

2. Choose a lock tongue depending on how the door/hatch is closed.

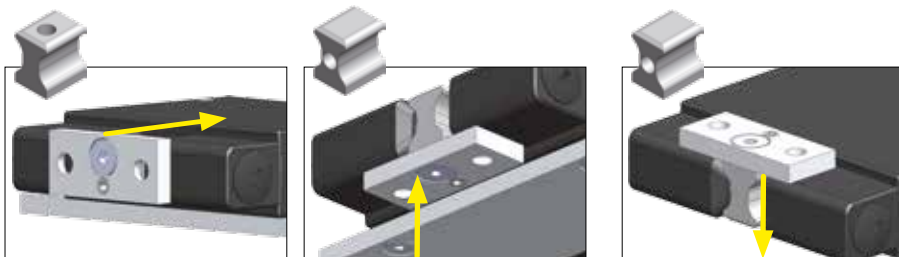

Lock from front - Tongue A

Lock from lower side - Tongue B

Lock from upper side - Tongue B

Lock tongue A

Selected when the door closes to the Dalton front

Lock tongue B

Selected when the door closes to Dalton's upper or lower side

For Dalton L00 both lock tongues can be used regardless of the operating direction

3. Choose a fixing kit that fits your installation.

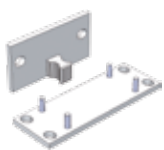

Fixing kit 1
for Dalton and lock tongue

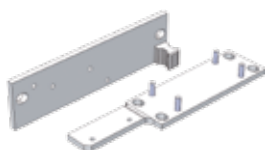

Fixing kit 2
for Dalton and Adam and also for lock tongue and Eva

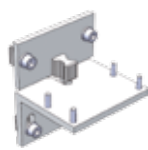

Fixing kit 3
for Dalton adapted to ABB Jokab Safety fencing system

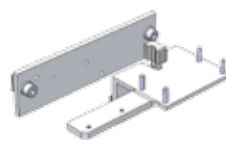

Fixing kit 4
for Dalton and Eden adapted to ABB Jokab Safety fencing system

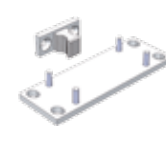

Fixing kit 5
for Dalton, small bracket for lock tongue

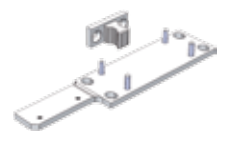

Fixing kit 6
for Dalton and Eden, small bracket for lock tongue

Read the manual for further information about correct installation of Dalton

Accessories - Dalton

Tina 12A junction block

Tina 12A can be used to connect two Daltons with Edens with one cable to the apparatus enclosure. The summed information that indicates the states of both the Dalton and Eden also goes to the apparatus enclosure.

Transfer cables













A transfer cable can be used when the Dalton's 8-pole connector is to be connected to the 5-pole M12 connector of Tina 4A or Tina 8A. Note that the info-signals from Dalton and Adam can not be used.

Technical data – Dalton

Article number	
Dalton L00	2TLA020038R3000
Dalton M11	2TLA020038R3100
Dalton M12	2TLA020038R3200
Dalton M31	2TLA020038R3300
Lock tongue A	2TLA020039R0800
Lock tongue B	2TLA020039R1000
Fixing kit 1	2TLA020039R0000
Fixing kit 2	2TLA020039R0100
Fixing kit 3	2TLA020039R0200
Fixing kit 4	2TLA020039R0300
Fixing kit 5	2TLA020039R0400
Fixing kit 6	2TLA020039R0500
Accessories	
DA 1	2TLA020053R0000
M12-CT0214	2TLA020060R0100
Tina 12A	2TLA020054R1800
Level of safety	
For interlocking switch Eden. Not valid for locking function.	
IEC/EN 61508-1...7	SIL3
EN 62061	SIL3
EN ISO 13849-1	PL e/Cat. 4
PFH_D	
For interlocking switch Eden. Not valid for locking function.	
	4.50×10 ⁻⁹
Locking function	
	M - Locked when energised L - Only ball latch
Colour	
	Black
Operating voltage	
	24 VDC +25/-20%
Current consumption	
Unlocked	40 mA
Locked	130 mA
Lock input	5 mA
Information output	Max. 10 mA
Eden	
	See the data for Adam M12
Operating temp. range	
	-10°C to +55°C
Enclosure classification	
	IP67
Holding force	
Unlocked	25-100 N
Locked	2000 N
Material	
Ball catch, securing plate	Anodised aluminium
Enclosure	Anodised aluminium
Lock tongue, securing plate	Stainless steel
Chemical resistance	
Stainless steel	Good resistance against most acids except hydrochloric acid and sulphuric acid.
Anodised aluminium	Very good resistance against corrosion, good resistance to most acids.

Connections		Connector to connect Dalton (varies depending on type)	
		8-pole male plug, M12	
		5-pole male plug, M12	
		Outlet for externally connected Adam female plug M12, 5-pole	
Colour markings (pins)			
Function	8-pole	Colour	5-pole
Dynamic input signal, Adam	1	(White)	
+24 VDC	2	(Brown)	1 (Brown)
Lock signal	3	(Green)	4 (Black)
Not used	4	(Yellow)	2 (White)
Information Adam	5	(Grey)	
Dynamic output signal, Adam	6	(Pink)	
0 VDC	7	(Blue)	3 (Blue)
Information Dalton	8	(Red)	5 (Grey)
Warning Dalton locks mechanically. If the lock is forced, the Dalton can be permanently damaged.			
Conformity (lock only)		EN 61000-6-4:2007, EN 61000-6-2:2005	

LED indication – Dalton

LED indication		Information function
 =Red	 =Green  =Paus	
		1 Locked
		0 Closed but unlocked
		0 Open
Alarm:		
		1Hz Lock has not entered the unlocked state
		1Hz Eden or ball catch not in position = open
		1Hz Open, locking not permitted
		1Hz Lock has not entered the locked state
		1Hz Undervoltage - locking not permitted
		1Hz Overvoltage
		1Hz Overtemperature (> 80°C)

Dalton Dimensions

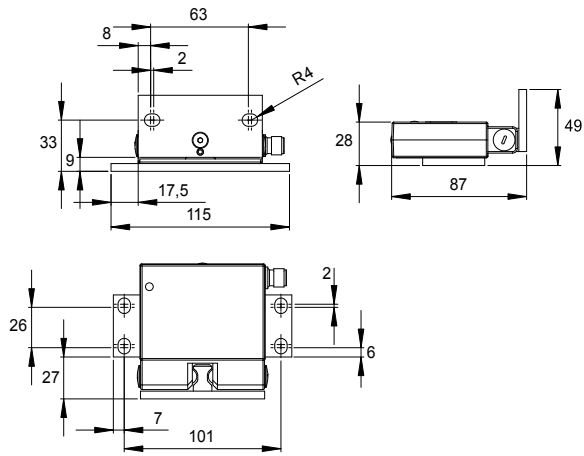

Bracket 1 with Dalton

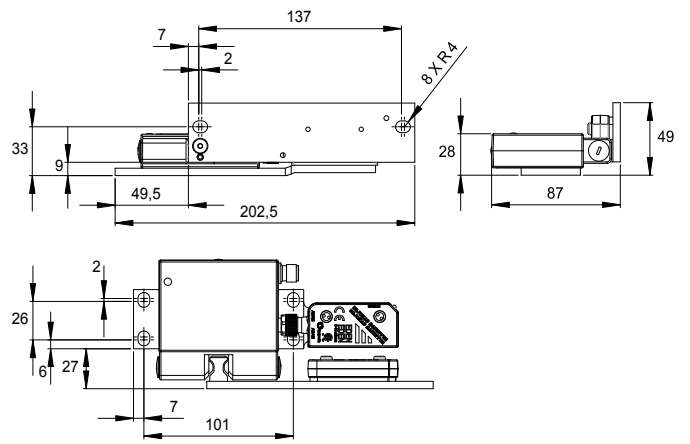

Bracket 2 with Dalton and Eden

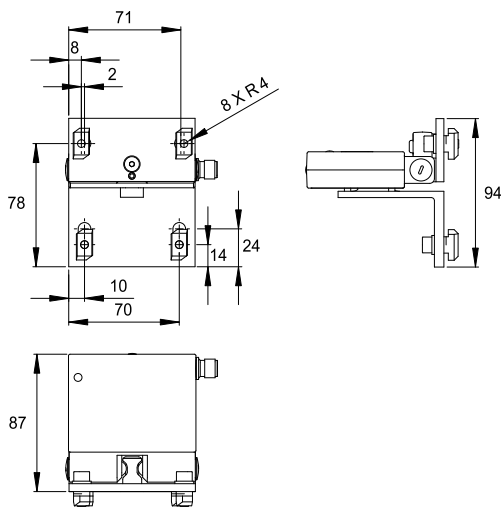

Bracket 3 with Dalton

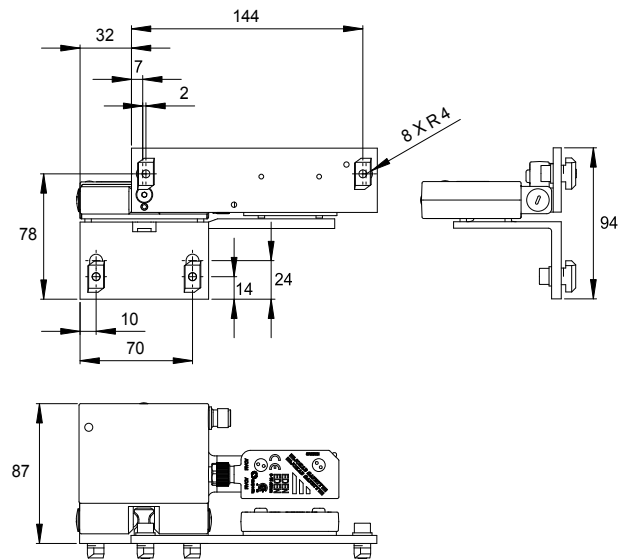

Bracket 4 with Dalton and Eden

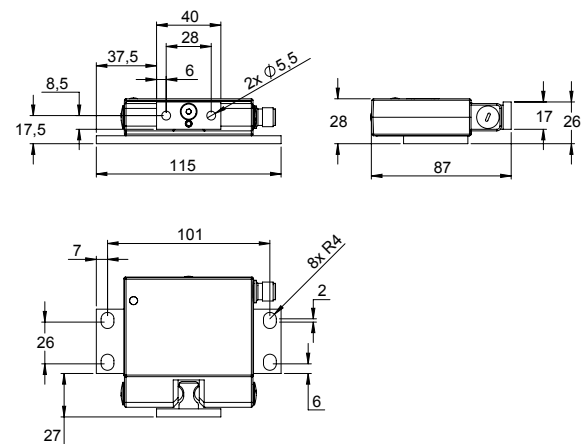

Bracket 5 with Dalton

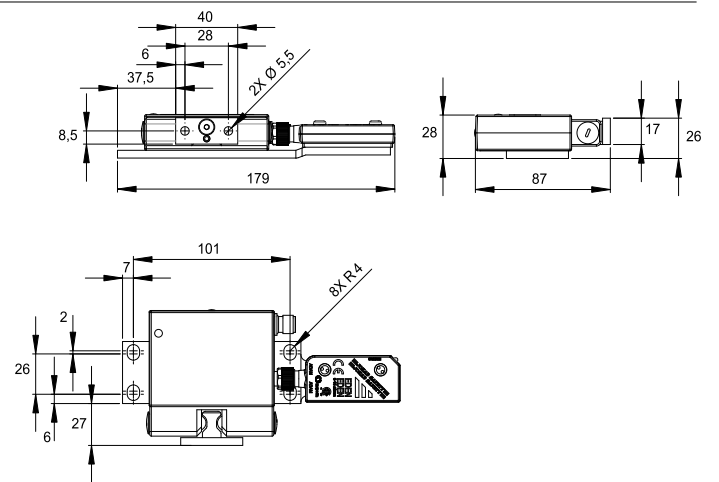

Bracket 6 with Dalton and Eden

Dalton

Connection examples

Connection example – Dalton M11, M31 and M12

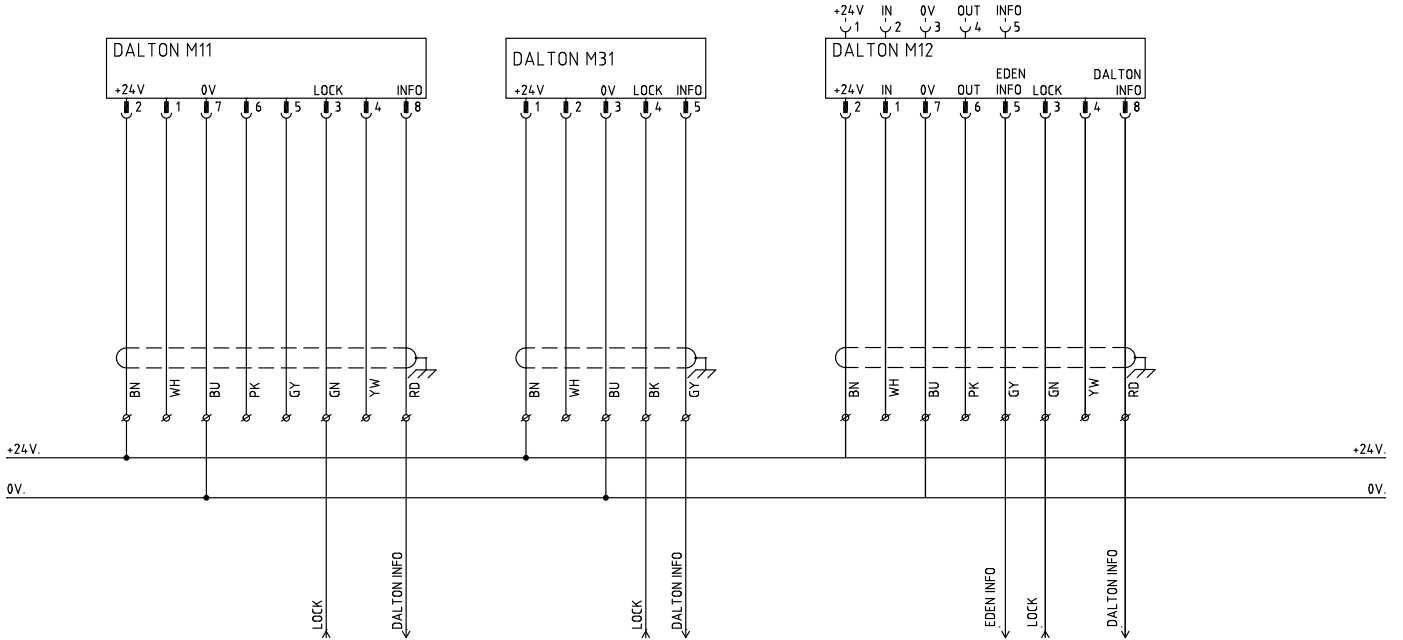

9

Connection example – Dalton M12 and Vital

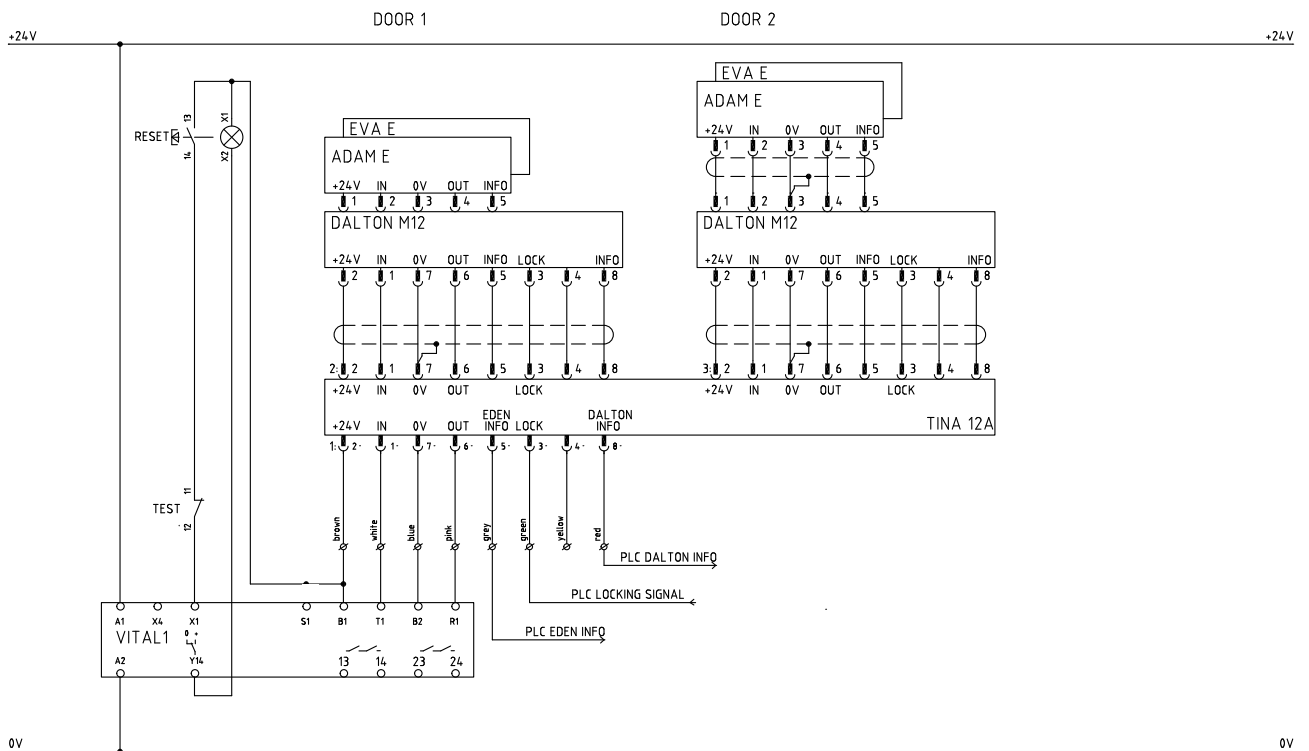

Dalton

Connection examples

Connection example – Dalton M12 and Eden through Tina 4A

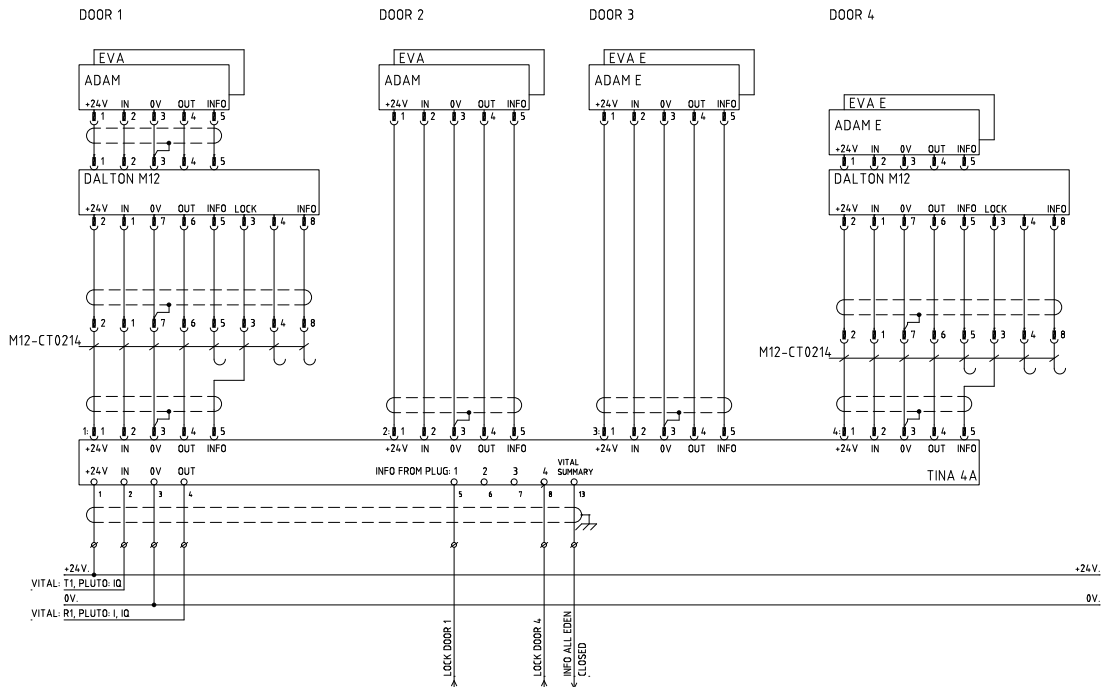

Connection example – Dalton M12 and Eden through Urax (AS-i)

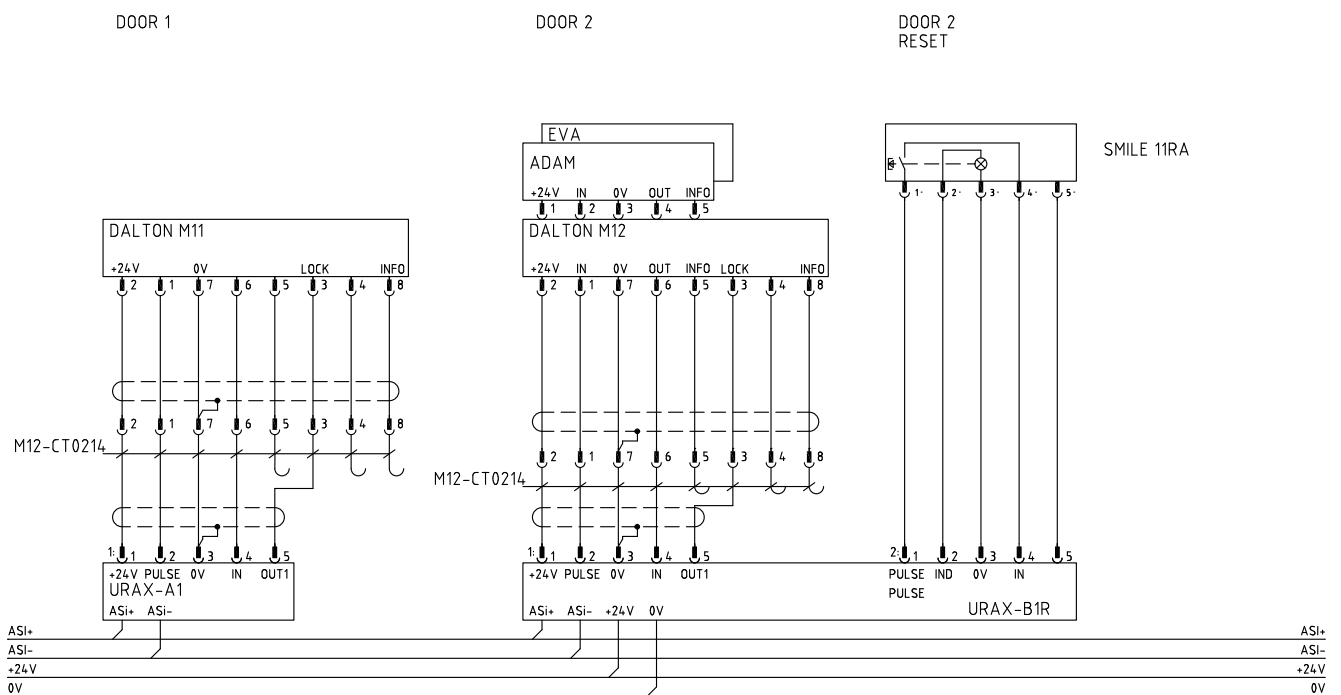

Safety and process lock

Knox



Knox - Double safety lock as specified in PL e/Cat. 4

Knox is a double lock that complies with the highest safety level (two lock cylinders with monitored positions) that can be used both as a safety and process lock. The locking function is electrically controlled and is bi-stable, i.e. it retains its position (unlocked/locked) in the event of a power failure. Dual signal for unlocking is safe at both short-circuits and cable breaks.

The handles operate as they would on a normal door but the exterior handle also have a reset function, why a separate reset button is not necessary and the interior handle that can be used for emergency opening also in locked state. The design and durability of the lock mean that it is ideal for harsh environments as the sensors are non-contact and the lock is manufactured of stainless steel. Knox is available in a number of adaptations such as left-hung door, right-hung door, inward and outward opening, with manual unlocking and for sliding door.

Approvals:



Application:

- Safe locking of door to a cell/line with long stopping time.
- Prevents unintentional interrupts of processes

Features:

- Double locking function as specified in PL e/Cat.4 (EN ISO 13849-1)
- Withstands harsh environments
- Status information with LEDs on the lock and at cable connection.
- Controlled in locked and unlocked positions - position power failure.
- Electronic connection only on the door frame.
- Robust design



Knox is easy to assemble, adjust and dismantle in and out of the T-slot of the Quick-Guard fencing system.

Knox in 4 different states



Open



Emergency opened



Reset, openable



Operational mode locked and reset
(emergency opening only)

Models and ordering data

Door part	Right	Left
Outward opening without manual unlocking	Knox 1A-R v2 2TLA020105R5000	Knox 1A-L v2 2TLA020105R5100
Outward opening with manual unlocking	Knox 1AX-R v2 2TLA020105R5800	Knox 1AX-L v2 2TLA020105R5900
Inward opening without manual unlocking	Knox 1B-R v2 2TLA020105R5200	Knox 1B-L v2 2TLA020105R5300
Inward opening with manual unlocking	Knox 1BX-R v2 2TLA020105R6100	Knox 1BX-L v2 2TLA020105R6300
Sliding door without manual unlocking	Knox 1F-R v2 2TLA020105R6400	Knox 1F-L v2 2TLA020105R6500
Sliding door with manual unlocking	Knox 1FX-R v2 2TLA020105R6400	Knox 1FX-L v2 2TLA020105R6500
Frame part		
Knox safety lock	Knox 2A v2 2TLA020105R2200	
Knox process lock	Knox 2X v2 2TLA020105R2300	
Accessories		
PC plate for Knox on mesh door	2TLA020106R0000	When mounting Knox on door with mesh the accessory PC plate for Knox is recommended. This is to avoid emergency opening from the outside.
Escutcheon plate for Knox (without emergency release handle)	2TLA020106R0600	When mounting Knox on a low door it is recommended to replace emergency release handle to prevent opening from the outside by reaching over.

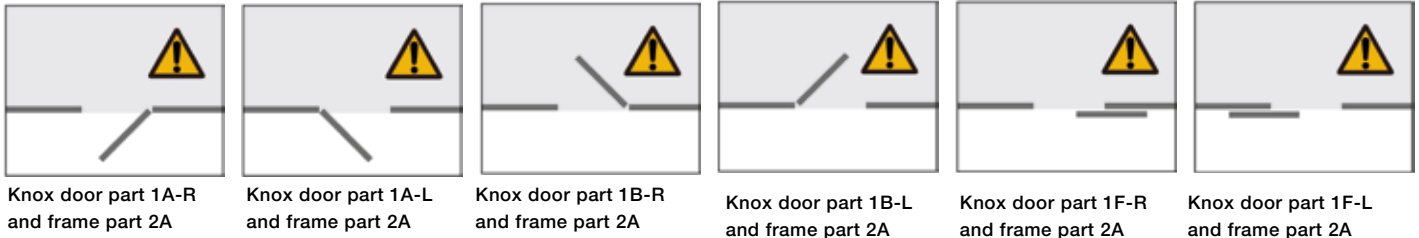

Maintenance mode

If any work is to be carried out inside the hazardous area, a padlock can be put in place in any of the two locking bolts to prevent the door from locking. This can also act as an indication of presence within the hazardous area (only helpful if operators are informed of the use of padlocks).

NOTE! The use of padlocks is not a part of the safety function and only serves as an additional measure to reduce the risk of entrapment.

NOTE! Cable outlet on frame part must be mounted upwards.

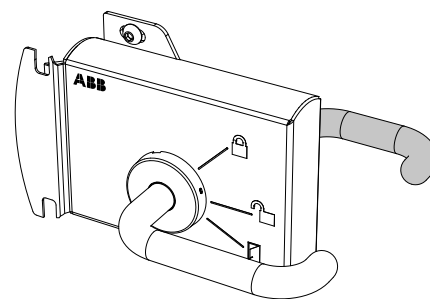
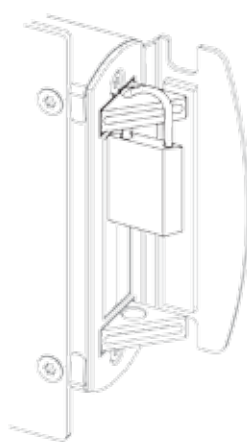

Door part Knox1

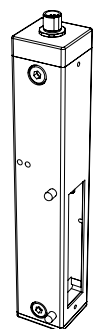

Frame part Knox 2

Technical data – Knox

Level of safety	
EN ISO 13849-1	PL e/Cat. 4
PFH _d	4.50×10 ⁻⁹
Lock function	S/M - unlocked and locked with voltage.
Operating voltage	24 VDC +/- 10%
Operating temperatur	+5°C...+55°C
Power consumption	
Electronics	70 mA (in locked position)
Lock/lock inverse	135 mA (when locking/unlocking)
Total max	Knox 2A 160mA, Knox 2x 165mA
Information output	Max. 10 mA
Insulation class	IP65
Holding strength	
Unlocked	5000 N (10,000 N ultimate breaking strength)
Locked	5000 N (10,000 N ultimate breaking strength)
Connection	Male plug M12, 8-pole
Connections Knox 2A	
Function	8-pole Colour
Dynamic input signal	1 (White)
+24 VDC	2 (Brown)
Lock	3 (Green)
Lock inverse	4 (Yellow)
Information Locked	5 (Grey)
Dynamic output signal	6 (Pink)
0 VDC	7 (Blue)
Information reset	8 (Red)
Connections Knox 2X	
Function	5-pole Colour
+24 VDC	1 (Brown)
Dynamic signal input	2 (White)
0 VDC	3 (Blue)
Dynamic signal output	4 (Black)
Lock	5 (Grey)
Warning	
Knox locks mechanically. Forcing the lock may damage Knox permanently.	
When mounting Knox on door with mesh the accessory PC plate for Knox is recommended. This is to prevent emergency opening from the outside.	
When mounting Knox on a low door it is recommended to replace emergency release handle with the accessory Escutcheon plate for Knox to prevent opening from the outside by reaching over.	
Conformity	2006/42/EG EN ISO 12100-1/2:2003, EN ISO 13849-1:2008, EN 62061:2005, EN 1088

LED indicator – Knox

LED indicator	
<div style="display: flex; gap: 10px;"> ■ =Red ■ =Green =Paus </div>	Function
LED 1 <div style="display: flex; gap: 5px;"> </div>	Locked (and reset) Locked, no dynamic signal in
<div style="display: flex; gap: 5px;"> </div>	Unlocked
LED 2 <div style="display: flex; gap: 5px;"> </div>	Reset Not reset
Alarm LED 2 <div style="display: flex; gap: 5px;"> </div>	Dirt indicator reset sensor Reset Not reset

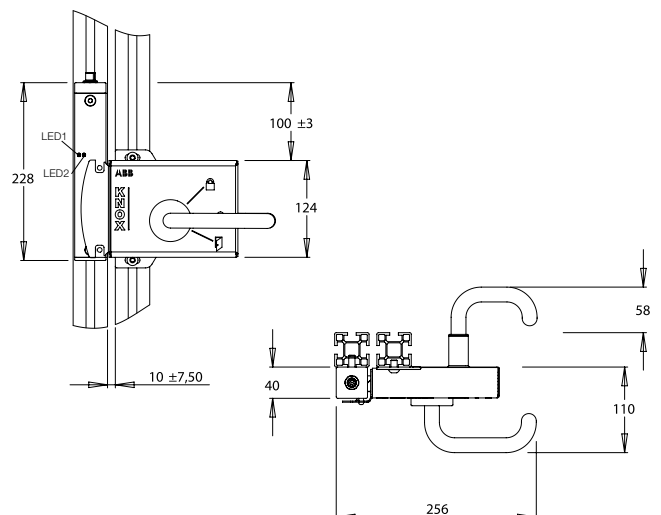

Knox

Connection examples

Connection example - Knox

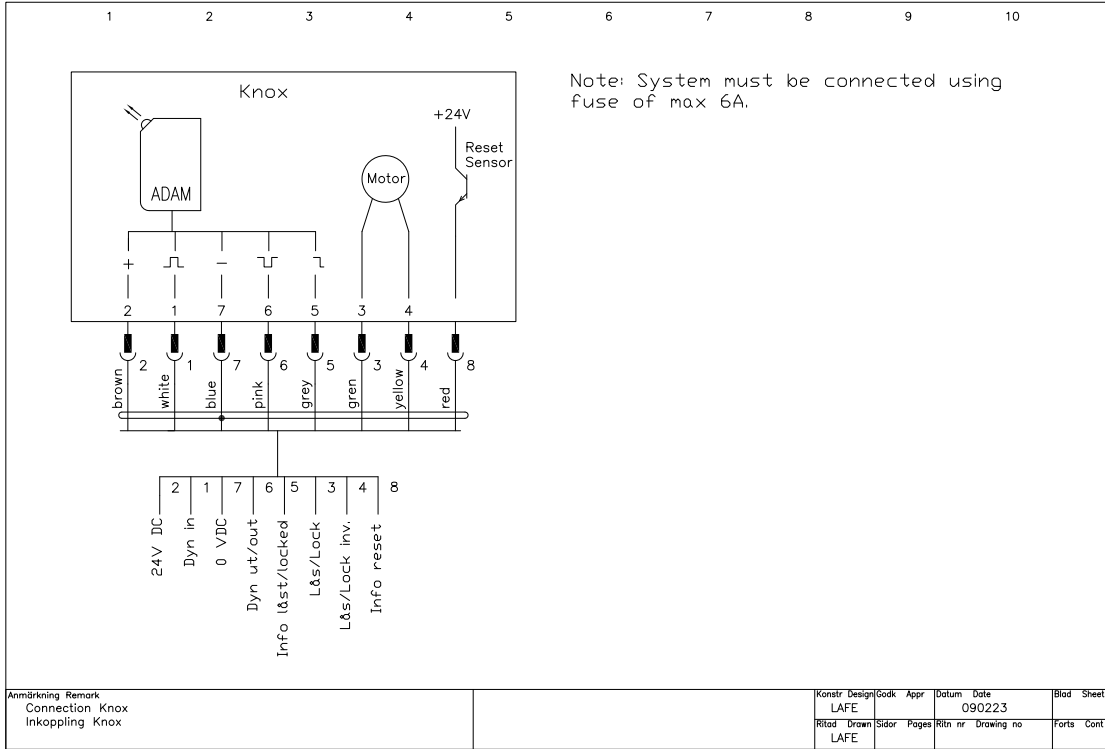

9

Connection example - Knox with other unlocking

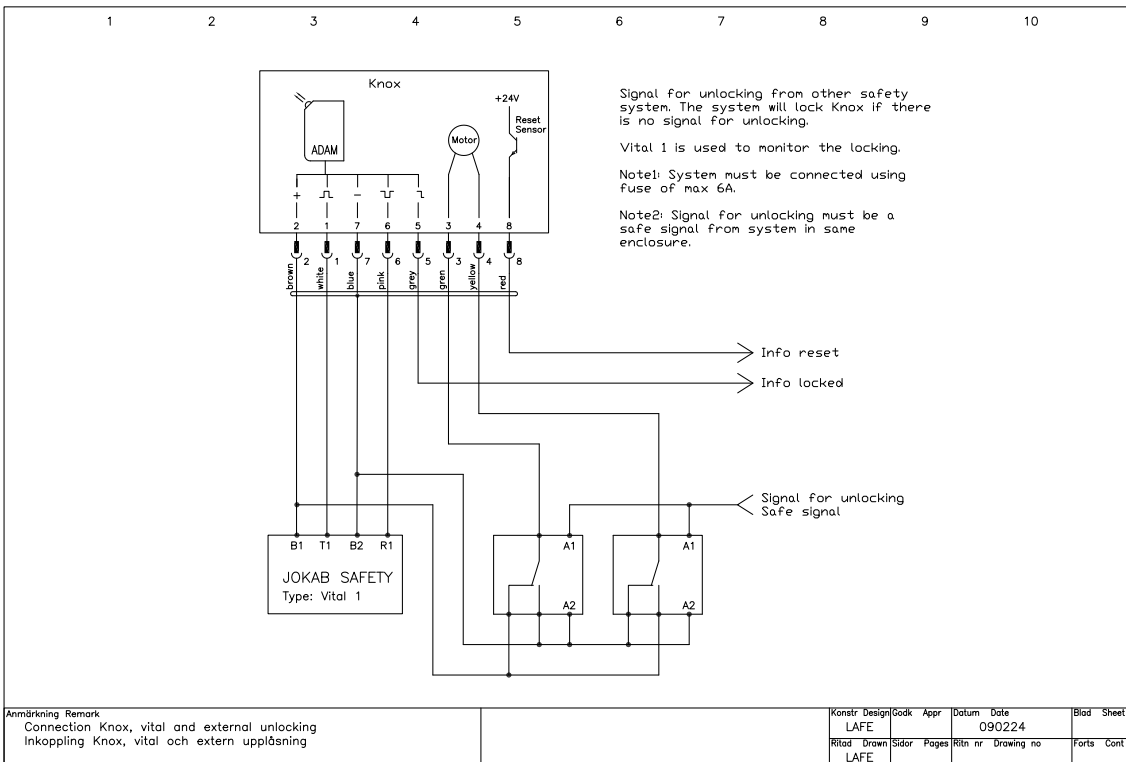

Knox

Connection examples

Connection example - Knox with downtime monitor

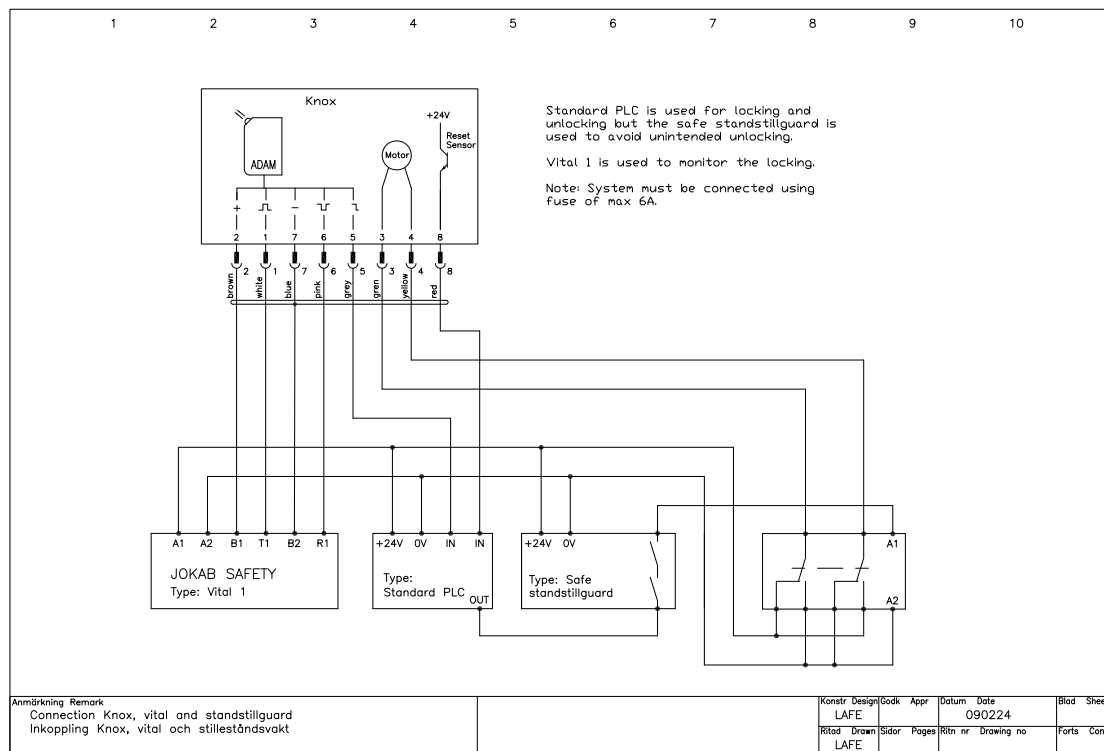

Safety Interlock Switch MKey5



Approvals:



Application:

- Gates
- Hatches

Features:

- 2NC + 1NO (actuator in)
- 4 actuating positions
- Holding force 12 or 40N
- Up to PL e/Cat.4
- Plastic, Plastic with stainless steel head or stainless steel

Switch operational description

MKey5 Interlock switches are designed to provide position interlock detection for moving guards. They are designed to fit the leading edge of sliding, hinged or lift off machine guards. The actuator is fitted to the moving part of the guard and is aligned to the switch entry aperture.

The head can be rotated to provide four given actuator entry positions. When the actuator is inserted into the switch the safety contacts close and allow the machine start circuit to be enabled. MKey5 has two versions regarding holding force, 12N and 40N. MKey5 has several types of actuators as an option. A standard actuator key is always delivered with interlock switches.

Material

Depending on the environment where the switch will be used, different material can be chosen on the Mkey5. The basic version is in a full plastic body (polyester) and in cases where the demands are higher on the interlock switch head, there is a version with a plastic body and with a stainless steel head. Both these types give the MKey5 interlock switch a rating of IP67.

In harsh applications as for food processing and chemical industry there is a MKey5Z Interlock switch with a total rugged stainless steel 316 body. This version has IP69K enclosure protection (maintained by a double seal lid gasket) and can be high pressure hosed with detergent at high temperature.

Positive forced disconnected contacts

A positive forced contact provides a forced disconnect of the safety contacts at the withdrawal of the actuator. The design of the MKey5 ensures that the contacts will not fail or be held in a normally closed position, due to failure of the spring mechanism or that welding/sticking of the contacts can occur.

Safety level

The positive forced disconnect contacts gives a high safety level and the interlock switch has an anti-tamper mechanism. By combining the MKey5 with one of our suitable safety control module, for example a safety relay from the RT-series, Pluto safety-PLC or Vital module, the requirements for both hatch and gate switch supervision can be fulfilled. To obtain the highest level of safety, two switches per gate are required.

Explosion Proof version (X)

MKey5 also exist in versions with certified explosion proof contact block (X-versions). MKey5ZX is in stainless steel and can be used in European Zone 1, 2, 21,22 environments (Gas and Dust). Preassembled with 3 meter cable.

Regulations and Standards

The MKey5 is designed and approved in accordance to relevant standards. Examples of relevant standards are EN 1088, IEC/EN 60947-5-1, EN 60204-1, EN ISO 13849-1, EN 62061 and UL 508.

Technical data – MKey5 series

Article number	
Standard	
MKey5 - 12N	2TLA050003R0100
Mkey5+ - 40N	2TLA050003R0101
Stainless steel head	
MKey5 - 12N	2TLA050003R0110
MKey5+ - 40N	2TLA050003R0111
Full stainless steel	
MKey5Z - 12N	2TLA050003R0120
MKey5+Z - 40N	2TLA050003R0121
MKey5ZX (EX)	2TLA050003R0125
Level of safety	
EN ISO 13849-1	Up to PL e/Cat. 4 depending upon system architecture
EN 62061	Up to SIL3 depending upon system architecture
Safety data	
Mechanical reliability B_{10d}	2.5×10^6 operations at 100mA load
Proof test interval (life)	35 years
MTTF _d	356 years (8 cycles per hour/24 hours per day/365 days)
Utilisation category	
	AC15 A300 3A
Force/travel for positive opening	
	6 mm
Acuator entry mini. radius	
	175 mm Standard Key 100 mm Flexible Key
Max. approached/withdrawal speed	
	600 mm/s
Actuator	
	Stainless steel
Mechanical life	
	1 million switch operations
Rated insulation/withstand voltage	
	500VAC / 2500VAC
Vibration resistance	
	IEC 68-2-6, 10-55Hz+1Hz, excursion: 0.35 mm, 1 octave/min
Contacts (actuator key inserted)	
	2NC + 1NO (NC are direct opening action)
Thermal current (Ith)	
	10A
Enclosure protection	
MKey5	IP67
MKey5Z(X)	IP69K and IP67
Operating temperature	
	-25°C to +80°C
Conduit entries	
	3 x M20
Material	
MKey5	Polyester or/and stainless steel 316
MKey5Z(X)	Stainless steel 316
Colour	
	Red or stainless steel
Mounting position	
	Any
Mounting bolts	
	Body 2 x M5, actuator 2 x M5
Explosion Proof version (X)	
Classification	
	Ex d IIC T6 (-20°C ≤ Ta ≤ +60°C) Gb Ex tb IIIC T85°C (-20°C ≤ Ta ≤ +60°C) Db
Rated Voltage	
	250V AC/DC
Rated Current	
	2 pole 4A 4 pole 2.5A

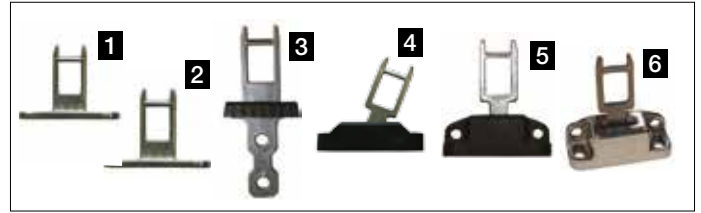

Actuator

1. Standard Key for plastic head	2TLA050040R0201
2. Standard Key for SS head	2TLA050040R0202
3. Flat Key	2TLA050040R0220
4. Flexible Key with plastic housing	2TLA050040R0221
5. Flexible Key with metal housing	2TLA050040R0203
6. Flexible Key with SS housing	2TLA050040R0204

(Key always in Stainless steel)

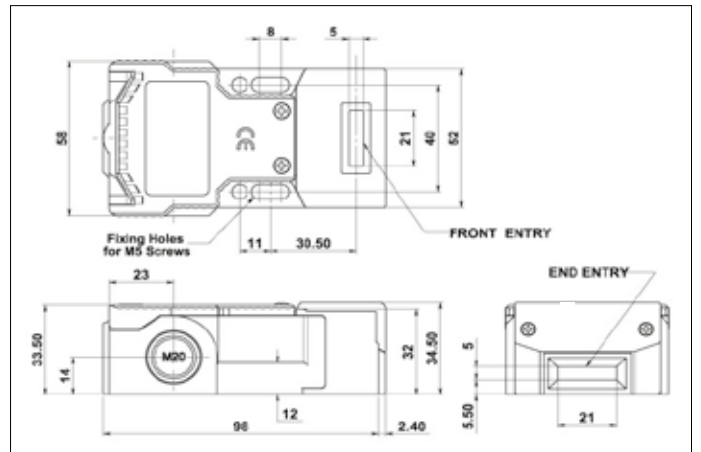

Dimension MKey5

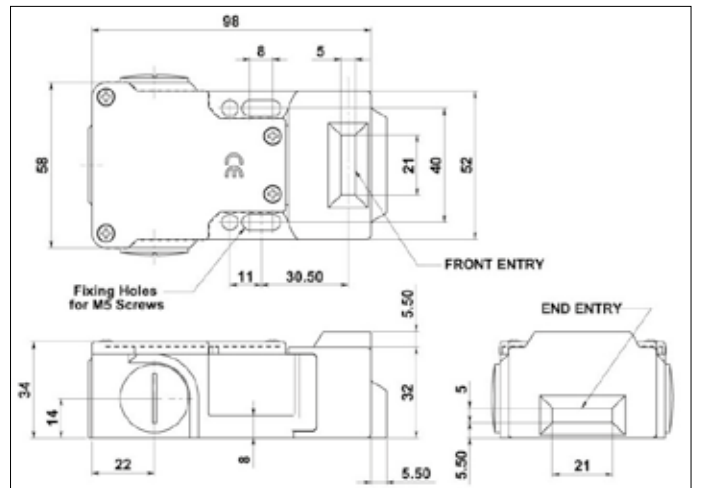

Dimension MKey5Z

For all MKey the normally closed (NC) circuits are closed when the guard is closed (actuators inserted).

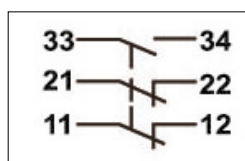

2 NC 1 NC 6.80 6 0 mm		
11/12	Open	
21/22	Open	
33/44		Open

Contact block configuration on 2NC, 1NO

Contacts at withdrawal of actuator

Safety Interlock Switch MKey8



Approvals:



Application:

- Gates
- Hatches

Features:

- Robust design
- 8 actuating positions
- High holding force
- Up to PL e/Cat.4
- Painted metal or stainless steel
- LED status indication

Switch operational description

MKey8 interlock safety switches are designed to provide position interlock detection and locking for moving guards. They are designed to fit the leading edge of sliding, hinged or lift off machine guards. The actuator is fitted to the moving part of the guard and is aligned to the switch entry aperture. The possibility to lock the switch in the protective position prevents unwanted access to machinery until dangerous operations have ceased.

The locking is useful when applications include:

- processes which cannot be interrupted, such as welding.
- machinery with a long stopping procedure, such as paper machinery that requires a long braking operation.
- prevention of unauthorised access to a particular area.

The head can be set in four positions, thus providing the safety device with eight different operating positions. The leading edges of the actuator key are reinforced and beveled in order to guide it properly into the hole. The MKey8 series have been developed with a high holding force of 2000N. MKey8 has several types of actuators as an option. A standard actuator key is always delivered with interlock switches.

Material

Depending on the environment where the switch will be used, different material can be chosen for the MKey8. The basic version has a rugged die cast housing with a rating of IP67. In harsh applications as for food processing and chemical industry there is a MKey8 Interlock switch with a total rugged stainless steel 316 body. This version has IP69K enclosure protection (maintained by a double seal lid gasket and seals) and can be high pressure hosed with detergent at high temperature.

Two ways to interlock

The MKey8 is available in two basic versions, either with a spring lock or an electro-magnetic lock.

In the spring lock version, the locking mechanism moves into the locked position directly when the door is closed and the actuator key is pushed into the switch. The actuator key can only be released and the gate opened by supplying operational voltage to the solenoid (A1-A2). The MKey8 also has an emergency rear release 'unlocking' facility to enable the actuator key to be released without the energisation of the solenoid (A1-A2). This version is called MKey8ER.

MKey8M is the electro-magnetic lock version, the locking mechanism is only in the locked position when the solenoid (A1-A2) is supplied with operating voltage. Release of the actuator key is only possible when the operating voltage is removed from the solenoid (A1-A2). The solenoid voltage can be 24 VDC or 230 VAC depending on choice.

Safety level

The MKey8 has double forced disconnection contacts connected to the actuator key and the locking mechanism. The actuator key is designed to protect against unauthorised access; no tools, magnets or similar allow that the MKey8 can be tampered with. To achieve highest safety level in connection with the machine control system, it is recommended that the MKey8 is monitored by an appropriate ABB Jokab Safety safety relay, Pluto safety-PLC or Vital system. To obtain the highest level of safety, two switches per gate are required.

MKey8, MKey8M and MKey8Z

MKey8 -Standard version with spring lock

The version of MKey8 with die cast housing and spring lock. The switch has a contact block configuration of 2NC + 2NC with positive force disconnection contacts. One pair closes when the actuator key is pushed into the head (2NC). The other pair closes when the locking mechanism is in the locked position (2NC). There are two NO auxiliary circuits, 1NO circuit with indication of guard open and on another 1NO circuit indication of lock status.

MKey8Z - Stainless Steel version with spring lock

The version of MKey8 with rugged stainless steel housing and spring lock. The switch has a contact block configuration of 2NC + 2NC with positive force disconnection contacts. One pair closes when the actuator key is pushed into the head (2NC). The other pair closes when the locking mechanism is in the locked position (2NC). There are two NO auxiliary circuits, 1NO circuit with indication of guard open and on another 1NO circuit indication of lock status.

MKey8M - Power to lock version with magnetic lock

The version of MKey8 with die cast housing and magnetic lock. The switch has a contact block configuration of 2NC + 1 (NC + NO) with positive force disconnection contacts. One pair closes when the actuator key is pushed into the head (1NC + 1NO). The other pair closes when the locking mechanism is in the locked position (2NC). A 1NO/1NC circuit gives an indication of actuator status.

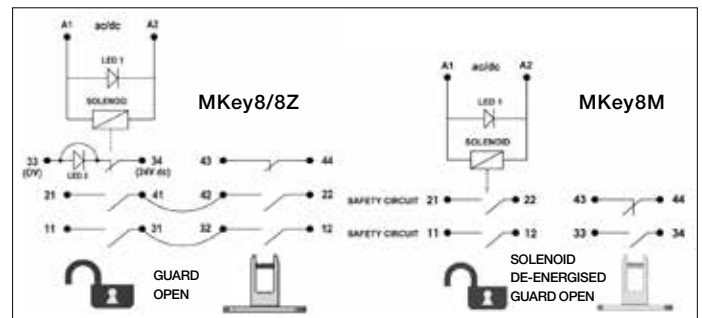

Schematic circuit: LED1 status of solenoid, LED2 status of lock (Terminals 33 - 34 are selectable to be used either as power feed to LED2 or as a voltage free auxiliary circuit to indicate lock status).

	6.0	5.0	0 mm
11/12	Open		
21/22	Open		
33/44			Open
43/44			Open

MKey8/8Z, Contacts at withdrawal of actuator.

	6.0	5.0	0 mm
11/12	Open		Solenoid energised
21/22	Open		Solenoid energised
33/34	Open		Tongue Inserted
43/44		Open	Tongue Inserted

MKey8M, Contacts at withdrawal of actuator.

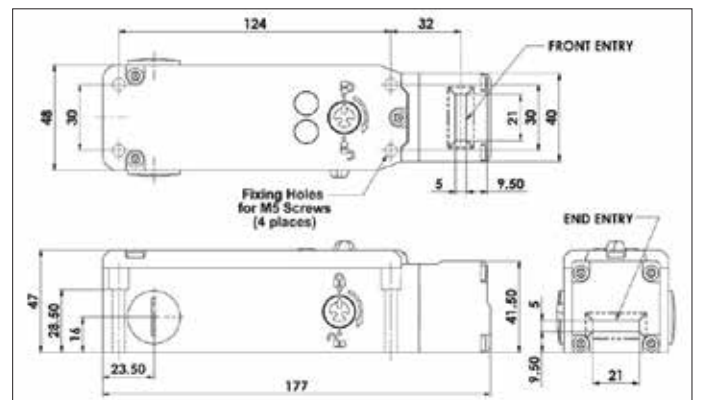

Dimensions MKey8, MKey8M and MKey8Z

MKey8ER

MKey8ER - Standard version with escape release

The version of MKey8 with die cast housing and spring lock with escape release. The switch has a contact block configuration of 2NC + 2NC with positive force disconnection contacts. One pair closes when the actuator key is pushed into the head (2NC). The other pair closes when the locking mechanism is in the locked position (2NC). There are two NO auxiliary circuits, 1NO circuit that indicates guard open and 1NO circuit that indicates lock status.

Features

The MKey8ER has manual release button at the rear of the housing. This can be used where the risk assessment for the application permit, a non latching manual escape of the switch lock in case of emergency. The switch must be mounted so that the release button is reachable from inside the active guard area. Press and holding the red button will release the lock mechanism and lock monitoring contacts while the guard can be pushed open.

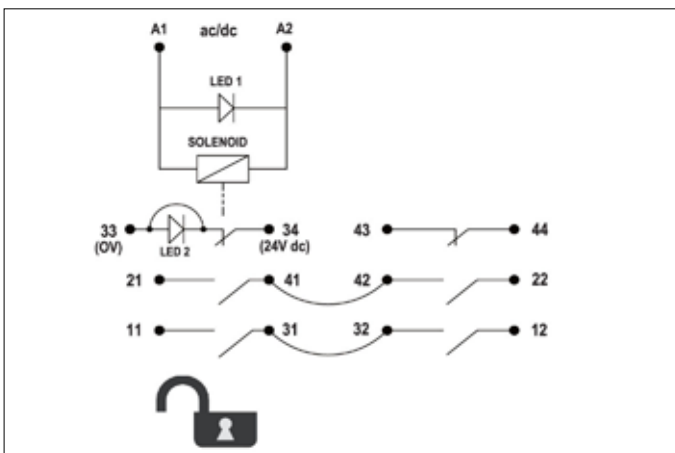
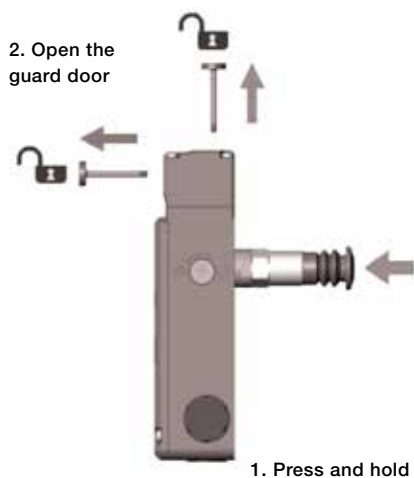

LED1 status of solenoid LED2 status of lock (terminals 33-34 are selectable to be used either as power feed to LED2 or as a voltage free auxiliary circuit to indicate lock status).

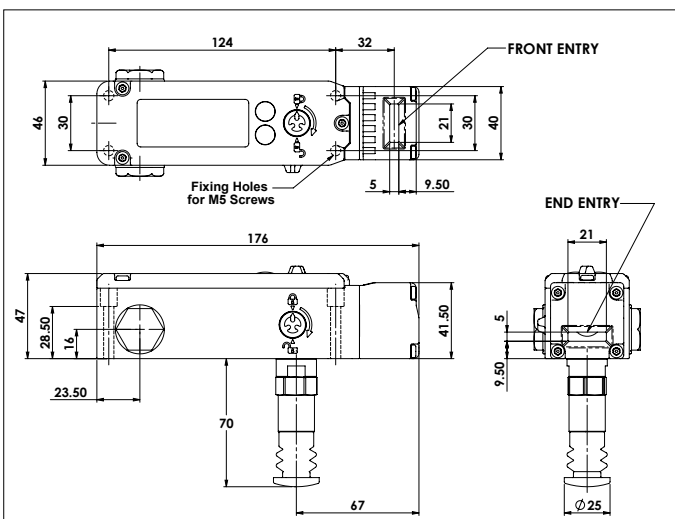

Dimensions MKey8ER

Technical data – MKey8 series

Article number	
MKey8 - Standard	
MKey8 - 24 VDC	2TLA050011R0132
MKey8 - 230 VAC	2TLA050011R0134
MKey8M - Power to Lock	
MKey8M - 24 VDC	2TLA050013R0132
MKey8M - 230 VAC	2TLA050013R0134
MKey8ER - Escape release	
MKey8ER - 24 VDC	2TLA050015R0132
MKey8ER - 230 VAC	2TLA050015R0134
MKey8Z - Stainless Steel	
MKey8Z - 24 VDC	2TLA050011R0122
MKey8Z - 230 VAC	2TLA050011R0124
Level of safety	
EN ISO 13849-1	Up to PL e/Cat. 4 depending upon system architecture
EN 62061	Up to SIL3 depending upon system architecture
Safety data	
Mechanical reliability B_{10d}	2.5×10^6 operations at 100mA load 35 years
Proof test interval (life)	356 years (8 cycles per hour/24 hours per day/365 days)
MTTF _d	
Utilisation category	
	AC15 A300 3A
Solenoid voltage (by part number)	
	24 VDC or 230 VAC, +/- 10%
Solenoid power consumption	
	12 W (MKey8M inrush 50 W)
LED 2 supply voltage	
	24 VDC, +/- 10% (MKey8, MKey8ER, MKey8Z)
Travel for positive opening	
	10 mm
Actuator entry mini. radius	
	175 mm Standard Key 100 mm Flexible Key
Max. approached/withdrawal speed	
	600 mm/s
Rated insulation/withstand voltages	
	600VAC / 2500VAC
Vibration resistance	
	IEC 68-2-6, 10-55 Hz+ 1 Hz excursion: 0.35 mm 1 octave/min.
Thermal current (Ith)	
	5A
Enclosure protection	
MKey8/M/ER	IP67
MKey8Z	IP69K and IP67
Operating temperature	
MKey8	-25°C to +55°C
MKey8M	-25°C to +40°C
MKey8ER	-25°C to +55°C
MKey8Z	-25°C to +55°C
Conduit entries	
	3 x M20
Material	
MKey8/M/ER	Die cast painted red
MKey8Z	Stainless steel 316
Colour	
	Red or stainless steel
Mounting position	
	Any
Mounting bolts	
	4 x M5

Regulations and Standards

The MKey8 is designed and approved in accordance to relevant standards. Examples of relevant standards are EN 1088, IEC/EN 60947-5-1, EN 60204-1, EN ISO 13849-1, EN 62061 and UL 508.



Actuator

1. Standard Key for SS head	2TLA050040R0202
2. Flat Key	2TLA050040R0220
3. Flexible Key with metal housing	2TLA050040R0203
4. Flexible Key with SS housing	2TLA050040R0204

(Key always in Stainless steel)



Manual release key for MKey8Z
2TLA050040R0400



Top or side manual release points (not on MKey8M)

8 actuators entry positions rotatable head

Safety Interlock Switch MKey9



Approvals:



Application:

- Gates
- Hatches

Features:

- Compact and robust
- 8 actuating positions
- High holding force
- Up to PL e/Cat.4
- LED status indication

Switch operational description

The MKey9 interlock safety switches are design to provide position interlock detection and locking for moving guards. They are designed to fit the leading edge of sliding, hinged or lift off machine guards. The actuator is fitted to the moving part of the guard and is aligned to the switch entry aperture. The possibility to lock the switch in the protective position prevents unwanted access to machinery until dangerous operations have ceased.

The locking is useful when applications include:

- processes which cannot be interrupted, such as welding.
- machinery with a long stopping procedure, such as paper machinery, that requires a long braking operation.
- prevention of unauthorised access to a particular area.

The head can be set in four positions, thus providing the safety device with eight different operating positions. The leading edges of the actuator key are reinforced and bevelled in order to guide it properly into the hole. The safety switch is design to have a high holding force of 2000N. MKey9 has several types of actuators as an option. A standard actuator key is always delivered with interlock switches.

Material

The MKey9 is made in a rugged polyester housing with a stainless steel head which give the switch a rating of IP67.

Two versions

The MKey9 is available in two basic versions, either with a spring lock or an electro-magnetic lock.

In the spring lock version, the locking mechanism moves into the locked position directly when the door is closed and the actuator key is pushed into the switch. The actuator key can only be released and the gate opened by supplying operational voltage to the solenoid (A1-A2).

MKey9M is the electro-magnetic lock version, the locking mechanism is in the locked position when the solenoid (A1-A2) is supplied with operating voltage. Release of the actuator key is only possible when the operating voltage is removed from the solenoid (A1-A2). The solenoid voltage is 24VDC.

Safety level

The MKey9 has double forced disconnection contacts to the actuator key and the locking mechanism. The actuator key is designed to protect against unauthorised access; no tools, magnets or similar allow that the MKey9 can be tampered with. To achieve maximum safety level in connection with the machine control system, it is recommended that the MKey9 is monitored by an appropriate ABB Jokab Safety safety relay, Pluto safety-PLC or Vital system. To obtain the highest level of safety, two switches per gate are required.

Regulations and Standards

The MKey9 is designed and approved in accordance to relevant standards. Examples of relevant standards are EN 1088, IEC/EN 60947-5-1, EN 60204-1, EN ISO 13849-1, EN 62061 and UL 508.

Technical data – MKey9 series

Article number	
MKey9 - 24VDC	2TLA050007R0112
MKey9M - 24VDC (power to lock)	2TLA050009R0112
Level of Safety	
EN ISO 13849-1	Up to PL e/Cat. 4 depending upon system architecture
EN 62061	Up to SIL3 depending upon system architecture
Safety data	
Mechanical reliability B_{10d}	2,5 x 10 ⁶ operations at 100mA load 35 years
Proof test interval (life)	356 years (8 cycles per hour/24 hours per day/365 days)
MTTF _d	
Utilisation category	AC15 A300 3A
Solenoid voltage	24 VDC or 230 VAC, +/- 10%
Solenoid power consumption	
MKey9	12 W
MKey9M	12 W (Inrush 50W)
LED 2 supply voltage	24 VDC, +/- 10%
Travel for positive opening	10 mm
Actuator entry mini. radius	175 mm Standard Key 100 mm Flexible Key
Max. approached/withdrawal speed	600 mm/s
Rated insulation/withstand voltages	600VAC / 2500VAC
Vibration resistance	IEC 68-2-6, 10-55 Hz+ 1 Hz excursion: 0.35 mm 1 octave/min.
Thermal current (I _{th})	5A
Conduit entry	1 x M20
Enclosure classification	IP67
Operating temperature	
MKey9	-25°C to +55°C
MKey9M	-25°C to +40°C
Head/body material	Stainless steel 316/polyester
Colour	Red
Mounting position	Any
Mounting bolts	4 x M5

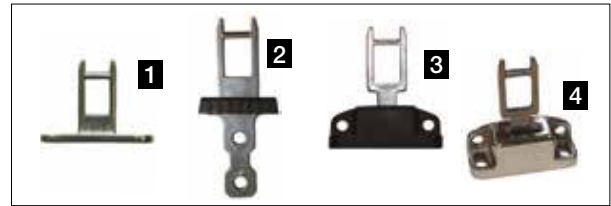

Actuator

- | | |
|------------------------------------|-----------------|
| 1. Standard Key for SS head | 2TLA050040R0202 |
| 2. Flat Key | 2TLA050040R0220 |
| 3. Flexible Key with metal housing | 2TLA050040R0203 |
| 4. Flexible Key with SS housing | 2TLA050040R0204 |
- (Key always in Stainless steel)



Top or side manual release points (not on MKey9M)

8 actuator entry positions rotatable head

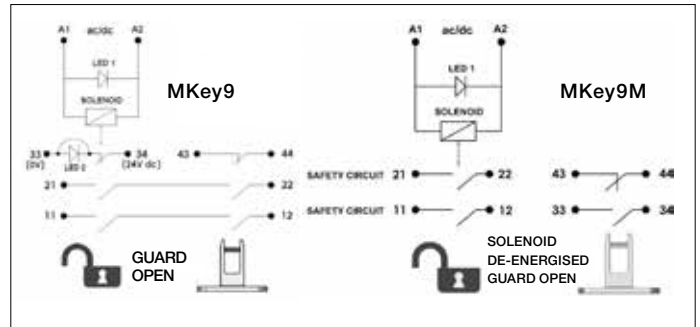

Schematic circuit MKey9 LED1 status of solenoid LED2 status of lock (Terminals 33 - 34 are selectable to be used either as power feed to LED2 or as a voltage free auxiliary circuit to indicate lock status).

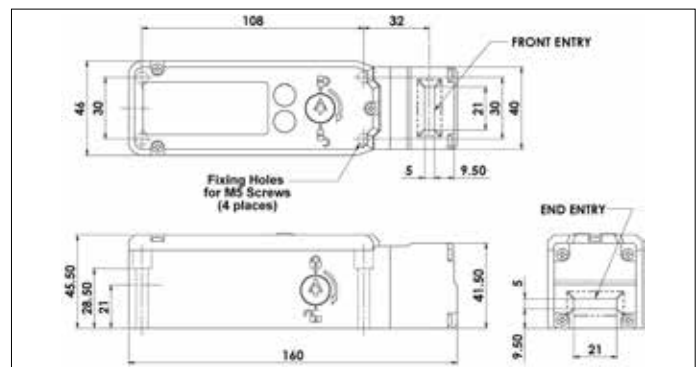

Dimensions MKey9 and MKey9M

	6.0	5.0	0 mm
11/12	Open		
21/22	Open		
33/34			Open
43/44			Open

MKey9, Contacts at withdrawal of actuator.

	6.0	5.0	0 mm
11/12	Open		Solenoid energised
21/22	Open		Solenoid energised
33/34	Open		Tongue Inserted
43/44		Open	Tongue Inserted

MKey9M, Contacts at withdrawal of actuator.



Control devices

Why should control devices be used? 10/3

Three-position devices

JSHD4 10/5

Safeball

One- and two-hand devices - Safeball 10/15

Two-hand control station JSTD25 10/19

Two-hand device

JSTD20 10/23

Why should Control Devices be used?

-for the machine operator to be able to directly start and stop dangerous machine movement.

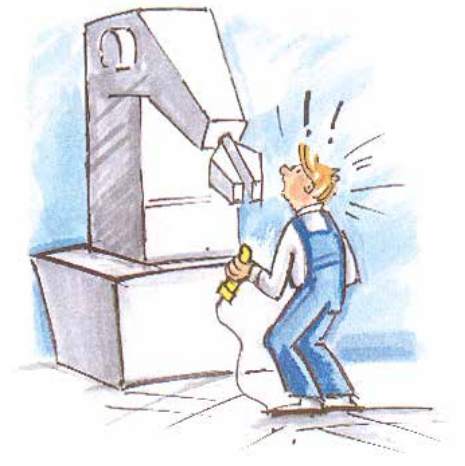

Ergonomic three-position device, JSHD4 with double three-position button that gives a stop signal when released or fully pressed in.

In an emergency situation the operator can either press harder or release the three-position device to stop the machine.

Three-position device

Three-position devices, hold-to-run devices and enabling devices are used during trouble-shooting, programming and test running when no other safety components are possible or suitable. The device is held in the hand and the operator can in an emergency situation either press harder or entirely release the device to stop the machine.

10

Three-position devices in different versions



Three-position device fitted to a machine control unit.

Panel assembly of JSHD4H2 on a programming unit for robots.

Two-hand control device

A two-hand control device is used when it is necessary to ensure that the operator's hands will be kept outside the risk area. If there is a risk that someone else other than the operator can reach into the machine without the operator seeing it, the safety device must be supplemented by something more, e.g. a light beam.

To be able to operate the machine with the two-hand device, all the buttons on the device have to be operated within 0.5 seconds of each other. This is called concurrence. All the buttons also have to be returned to their initial position before one can start again. If any button is released during the machine movement the machine will be stopped. Using the stopping time one can calculate the necessary safety distance. A safety distance of less than 100 mm must not be used.

The highest safety level is assured by connecting the buttons of the two-hand device to a safety relay. The safety relay checks for concurrence and that all the buttons have returned to their initial position before a new start can be made. The safety relay also gives a stop signal if any of the buttons are released.

The two-hand device protects against "after-grasp"; if the operator by reflex tries to enter or reach into a machine during the dangerous machine movement.



Two-channel all the way out to the hand
Safeball is an ergonomic two-hand control device with four built-in buttons.

Foot operated switches

A foot operated switch is used when the operator has to hold the material during processing. The pedal must have a safety cover to prevent unintentional start. For seated work one must also have a foot support to facilitate the operator holding his foot in the pedal's off position.

The highest safety level is secured by monitoring the pedal with a safety relay.

The foot operated switch is used when the operator has to hold the material with both hands during processing.



Safety foot operated switch with three-position function.

Three position device JSHD4



Approvals:



Use:

- Troubleshooting
- Test running
- Programming

Features:

- Ergonomic
- LED information
- Adaptable
- Cheat Safe (option)
- Available for AS-i

The safest solution during trouble shooting, programming and testing

Why three-positions?

An operator who is under pressure must be able to give a stop signal, whether in panic he/she pushes harder on the button or just lets go of it.

Three-position devices, hold-in and acceptance devices can be used for trouble shooting, programming and test running in situations where no other protection is available or feasible. If the operator has to enter a risk area to trouble shoot or run a test, it is extremely important that he/she is able to stop the machinery without having to rely on someone else to stand by a stop button that is further away. In addition, no-one else should be able to start the machinery from the outside after it has been stopped by use of the three-position device.

Hold to run device or Acceptance device, what is the difference?

Hold to run device: The start signal is given when the button is pressed. The stop signal is given when the button is released or pushed fully in.

Acceptance device: The start signal for separate starting is given when the button is pressed. The stop signal is given when the button is released or pushed fully in. "Separate start" means, for example, that a program start signal is sent to the robot via a separate button in the acceptance device.

The three-position device is designed to be ergonomic

The device is ergonomic, both in respect of its shape, fitting to the hand, and the way the buttons are operated. It is easy to operate the three-position device using just the fingers, and the middle position provides a secure resting position. The device has LED indications that show the operational status, i.e. stop or ready signal. The two additional buttons can be used, for example, for start/stop, up/down or forward/back. Internally the device is duplicated. The three-position function itself is built up of two completely independent three-position buttons which are felt by the user to be one button.

Cheat Safe three-position device with hand recognition

The three-position device JSHD4 has sensors which ensure that it is a human hand holding it. By using this, the safety level is increased, and the risk of manipulation or bypass of the safety function is reduced. It is no longer possible to expose the operator to danger by trying to lock the three-position device in run mode.

Three-position device adapted for AS-i

The three-position device JSHD4 also comes in a version adapted for direct attachment to the AS-i bus.

Highest safety level whether the button is pushed or released

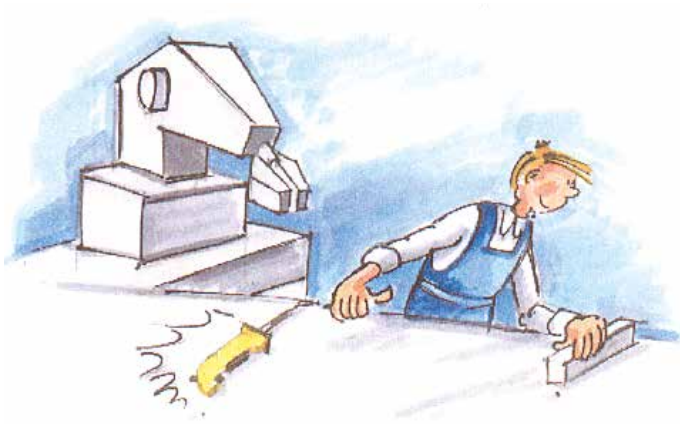

When the three-position button is released you will obtain a dual stop. It is essential that the machine stops when you put aside the three-position device, for example during adjustment.



When the three position button is pushed all the way in you will obtain a dual stop. It is essential that the machine stops in an emergency situation.

How does a a three-position device work?

Safety level

A safe Enabling or "Hold to Run" device should function as follows:

1. The Stop signal in released (top) and bottom position shall have the same safety level.
2. Provide a 'Start' or 'Ready' signal in a distinct middle position.
3. After a 'Stop' in the bottom position, a 'Start' signal or 'Ready' signal is not permitted until the three position push-buttons have been totally released and again pressed to the middle position. This function is achieved mechanically within the three position push-buttons in the device.
4. A Short or Open circuit in the connection cables shall not lead to a dangerous function e.g. 'Start' or 'Ready' signal.

In order to meet the above conditions, the three-position switch must be connected to a suitable safety relay with a two channel function, or Safety PLC, which can monitor that both three-position buttons are working and that there is no short or open circuit in the connection cable or the switch.

Regulations and standards

The JSHD4 is designed and approved in accordance with appropriate directives and standards. See technical data.

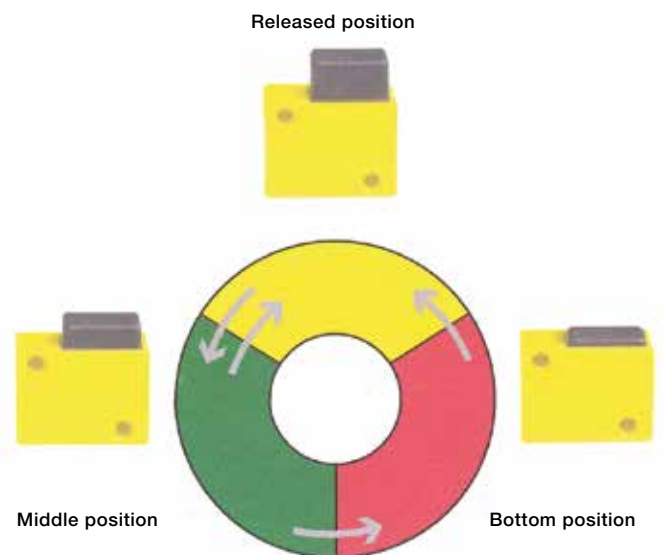

Design a three-position device for your needs

1. Choose between five different top units



JSHD4-1
2TLA020006R2100



JSHD4-2
2TLA020006R2200
– LEDs
– Front button
– Top button



JSHD4-3
2TLA020006R2300
– LEDs



JSHD4-4
2TLA020006R2400
– LEDs
– Front button



JSHD4-5
2TLA020006R2500
– LEDs
– Top button

2. Choose a bottom part suitable for your assembly



AA 2TLA020005R1000 with cable gland
AH 2TLA020005R1700 with cable gland and PCB with 10 screw connections
AJ 2TLA020005R1800 with cable gland and PCB with 16 screw connections



AB 2TLA020005R1100 with Cannon connection



AC 2TLA020005R1200 with M12 connection (5 poles)
AD 2TLA020005R1300 with M12 connection (8 poles)



AE 2TLA020005R1400 with M12 connection (8 poles) and emergency stop



AF 2TLA020005R1500 with M12 connection (4 poles) and 2 AS-i nodes (for front and top button)
AG 2TLA020005R1600 with M12 connection (4 poles) and 1 AS-i node (without front and top button)

3. Choose hand recognition for making your three position device cheat protected (option)

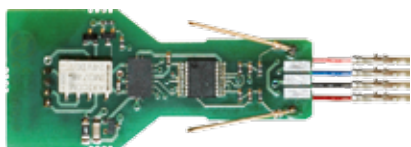

Anti-tamper PCB
2TLA020005R0900

4. Check the table if your combination is available

	JSHD4-1	JSHD4-2	JSHD4-3	JSHD4-4	JSHD4-5
AA without Cheat Safe	JSHD4-1-AA	–	–	–	–
AA with Cheat Safe	–	–	–	–	–
AB without Cheat Safe	–	JSHD4-2-AB	JSHD4-3-AB	JSHD4-4-AB	JSHD4-5-AB
AB with Cheat Safe	–	JSHD4-2-AB-A	JSHD4-3-AB-A	JSHD4-4-AB-A	JSHD4-5-AB-A
AC without Cheat Safe	JSHD4-1-AC	–	–	–	–
AC with Cheat Safe	–	–	–	–	–
AD without Cheat Safe	–	JSHD4-2-AD	JSHD4-3-AD	JSHD4-4-AD	JSHD4-5-AD
AD with Cheat Safe	–	JSHD4-2-AD-A	JSHD4-3-AD-A	JSHD4-4-AD-A	JSHD4-5-AD-A
AE without Cheat Safe	–	–	JSHD4-3-AE	–	–
AE with Cheat Safe	–	–	–	–	–
AF without Cheat Safe	–	JSHD4-2-AF	JSHD4-3-AF	JSHD4-4-AF	JSHD4-5-AF
AF with Cheat Safe	–	JSHD4-2-AF-A	JSHD4-3-AF-A	JSHD4-4-AF-A	JSHD4-5-AF-A
AG without Cheat Safe	–	–	JSHD4-3-AG	–	–
AG with Cheat Safe	–	–	–	–	–
AH without Cheat Safe	–	JSHD4-2-AH	JSHD4-3-AH	JSHD4-4-AH	JSHD4-5-AH
AH with Cheat Safe	–	JSHD4-2-AH-A	JSHD4-3-AH-A	JSHD4-4-AH-A	JSHD4-5-AH-A
AJ without Cheat Safe	–	JSHD4-2-AJ	JSHD4-3-AJ	JSHD4-4-AJ	JSHD4-5-AJ
AJ with Cheat Safe	–	JSHD4-2-AJ-A	JSHD4-3-AJ-A	JSHD4-4-AJ-A	JSHD4-5-AJ-A

5. Choose a bottom plate (option)



JSM50G, bottom plate for Safety Interlock switch MKey5/JSNY5
2TLA020205R6300



JSM50H, bottom plate for non-contact sensor Eden (Eva)
2TLA020205R6400

Technical data - JSHD4

Level of safety	PL e/Cat. 4
EN ISO 13849-1	
Electrical rating	
Three-position button	Maximum 30 VDC, 20mA (Minimum 10 VDC, 8mA)
Extra button	Maximum 50 VAC/VDC 0.2A
Protection class	IP65
Operating temperature	-10 to +50° C
Function indication	
Three-position buttons ready signal	'Yes', green LED 'No', red LED
Material	
Handle	Polyamide and Noryl
Rubber	Neoprene
Operation force	Approx. 15 N for three-position buttons (ON) Approx. 45 N for three-position buttons (OFF) Approx. 25 N for top/front push button
Mechanical life	1 000 000 cycles to middle position
Conformity	EN ISO 1200-1:2010, EN ISO 13849-1:2008, EN 60204-1:2006+A1:2009

Cabel with Cannon connector		Cabel with M12 connector		
Pin	12 conductors	Pin	8 conductors	5 conductors
A	White	1	White	Brown
B	Brown	2	Brown	White
C	Green	3	Green	Blue
D	Yellow	4	Yellow	Black
E	Grey	5	Grey	Grey
F	Pink	6	Pink	-
G	Blue	7	Blue	-
H	Red	8	Red	-
J	Black			
K	Purple			
L	Grey and Pink			
M	Red and Blue			

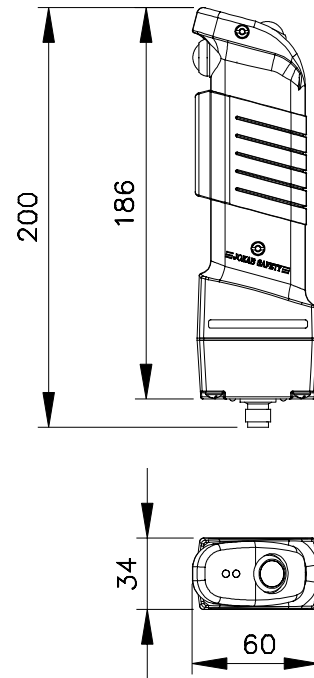

Accessories

 <p>Cable, available in different lengths.</p>	 <p>JSHD4 protection coat</p>	 <p>Spiral cable, available in different lengths.</p>	 <p>JSHK0 12 pole connector for JSHD4.</p>
 <p>JSM5B Wall bracket for interlock switches and three-position device.</p>	 <p>JSM55 Wall bracket for three-position device.</p>	 <p>Cable drum</p>	

JSHD4

Models and accessories

Three position devices - JSHD4

	Article number
JSHD4-1-AA	2TLA019995R0000
JSHD4-1-AC	2TLA019995R0100
JSHD4-2-AB	2TLA019995R0200
JSHD4-2-AB-A	2TLA019995R0300
JSHD4-2-AD	2TLA019995R0400
JSHD4-2-AD-A	2TLA019995R0500
JSHD4-2-AF	2TLA019995R0600
JSHD4-2-AF-A	2TLA019995R0700
JSHD4-2-AH	2TLA019995R0800
JSHD4-2-AH-A	2TLA019995R0900
JSHD4-2-AJ	2TLA019995R1000
JSHD4-2-AJ-A	2TLA019995R1100
JSHD4-3-AB	2TLA019995R1200
JSHD4-3-AB-A	2TLA019995R1300
JSHD4-3-AD	2TLA019995R1400
JSHD4-3-AD-A	2TLA019995R1500
JSHD4-3-AE	2TLA019995R1600
JSHD4-3-AF	2TLA019995R1700
JSHD4-3-AF-A	2TLA019995R1800
JSHD4-3-AG	2TLA019995R1900
JSHD4-3-AH	2TLA019995R2000
JSHD4-3-AH-A	2TLA019995R2100
JSHD4-3-AJ	2TLA019995R2200
JSHD4-3-AJ-A	2TLA019995R2300
JSHD4-4-AB	2TLA019995R2400
JSHD4-4-AB-A	2TLA019995R2500
JSHD4-4-AD	2TLA019995R2600
JSHD4-4-AD-A	2TLA019995R2700
JSHD4-4-AF	2TLA019995R2800
JSHD4-4-AF-A	2TLA019995R2900
JSHD4-4-AH	2TLA019995R3000
JSHD4-4-AH-A	2TLA019995R3100
JSHD4-4-AJ	2TLA019995R3200
JSHD4-4-AJ-A	2TLA019995R3300
JSHD4-5-AB	2TLA019995R3400
JSHD4-5-AB-A	2TLA019995R3500
JSHD4-5-AD	2TLA019995R3600
JSHD4-5-AD-A	2TLA019995R3700
JSHD4-5-AF	2TLA019995R3800
JSHD4-5-AF-A	2TLA019995R3900
JSHD4-5-AH	2TLA019995R4000
JSHD4-5-AH-A	2TLA019995R4100
JSHD4-5-AJ	2TLA019995R4200
JSHD4-5-AJ-A	2TLA019995R4300

Accessories

	Article number
Connectors:	
M12-C01 M12 5-pole female, straight	2TLA020055R1000
M12-C03 M12 8-pole female, straight	2TLA020055R1600
JSHK0 12-pole cannon female connector for JSHD4	2TLA020003R0300
Cable with 5 conductors:	
C5 Cable 5 x 0.34 cut to length (meters)	2TLA020057R0000
M12-C101 10 m cable and M12 female connector	2TLA020056R1000
M12-C201 20 m cable and cannon female connector	2TLA020056R1400
Cable with 8 conductors:	
C8 Cable 8 x 0.34 cut to length (meters)	2TLA020057R1000
M12-C103 10 m cable and M12 female connector	2TLA020056R4000
M12-C203 20 m cable and M12 female connector	2TLA020056R4100
Cable with 12 conductors:	
HKC12 Cable 12 x 0.25 cut to length (meters)	2TLA020003R5500
HK5 Cable 5 m and cannon female connector	2TLA020003R4700
HK10 Cable 10 m and connector	2TLA020003R4800
HK20 Cable 20 m and connector	2TLA020003R4900
HK16S4 spiral cable 1.6 m and cannon female connector	2TLA020003R5000
HK20S4 spiral cable 2.0 m and cannon female connector	2TLA020003R5100
HK32S4 spiral cable 3.2 m and cannon female connector	2TLA020003R5200
HK40S4 spiral cable 4.0 m and cannon female connector	2TLA020003R3500
HK60S4 spiral cable 6.0 m and cannon female connector	2TLA020003R3600
HK80S4 spiral cable 8.0 m and cannon female connector	2TLA020003R5300
HK-T2 Cable drum and connector	2TLA020003R5400
Brackets:	
JSM55 Wall bracket for three position device	2TLA040005R0500
JSM5B Wall bracket for 2 MKey5/JSNY5	2TLA040005R0700
Others:	
JSHD4 protection coat	2TLA020200R4600

Three-position devices for different types of assembly

Three-position push button JSHD2C

The button is the main component in a safe three-position solution. To achieve the highest safety level two buttons are used in a two-channel system.

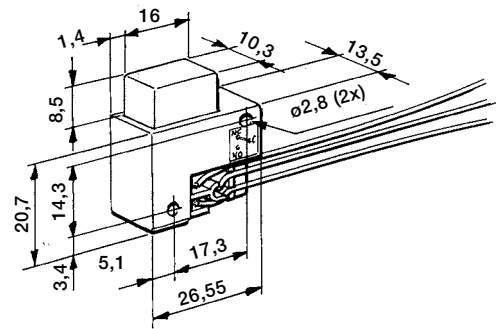
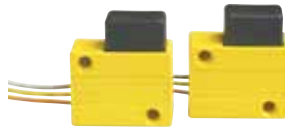

Panel assembly JSHD4H2

A panel assembly suitable for building into programming units or similar control boxes. Provides simultaneous activation of both of the three-position buttons.

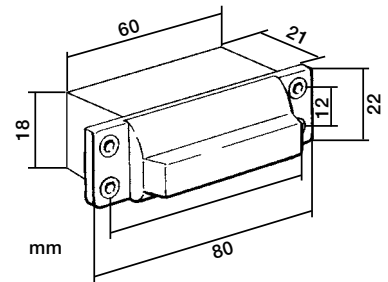

External assembly JSHD4H2A

The external assembly is similar to the panel assembly unit, although it is a 'handle' design making it suitable for assembly on the outside of a control box.

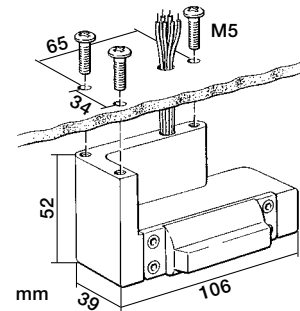

Standard versions

Article number	Model
2TLA020002R0200	JSHD4H2A Three-position device for external panel assembly
2TLA020002R3100	JSHD4H2 Three-position device for internal panel assembly
2TLA020001R1000	JSHD2C type E Three-position button
2TLA020001R1300	JSHD2C type K Three-position button
Complete JSHD4 with standard options are available to order separately	

JSHD4

Connection examples

JSHD4 to Pluto

Time-limited entrance/exit

After lifting the three-position device out of it's holder the door can be opened and shut for entrance to the safety zone within X seconds. To exit zone press S3. The time is set in the Pluto programme. The device detects the operators hand and prohibits tampering.

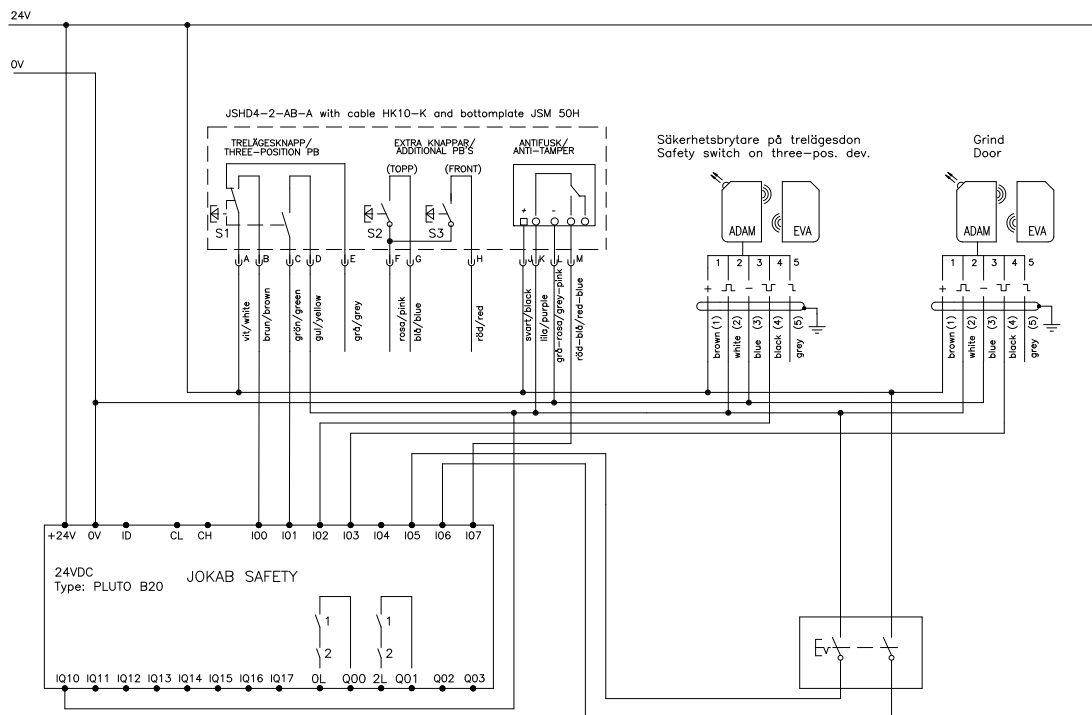

JSHD4 with various safety controllers

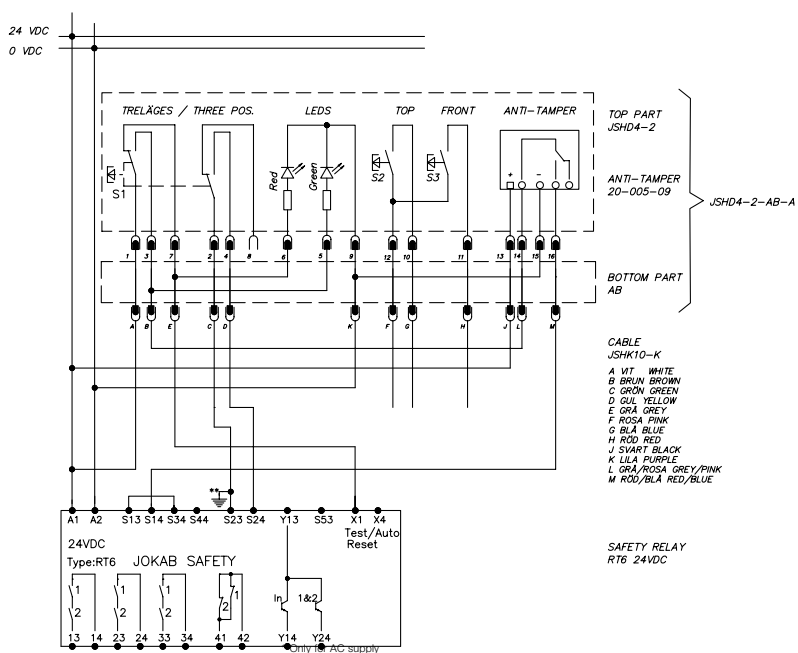

Connection with bottom parts AB

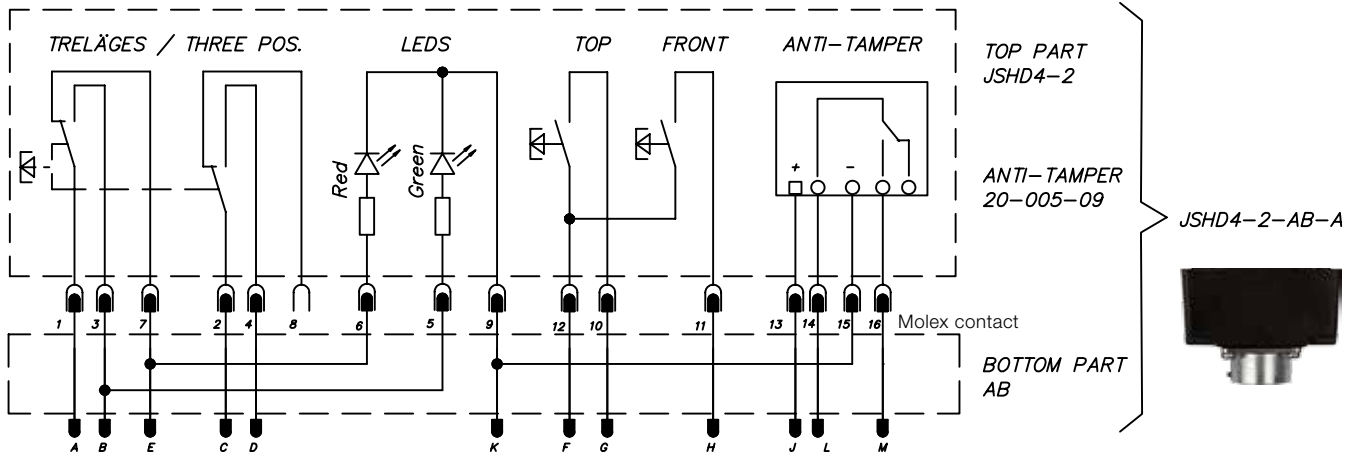

Connection with bottom parts AC

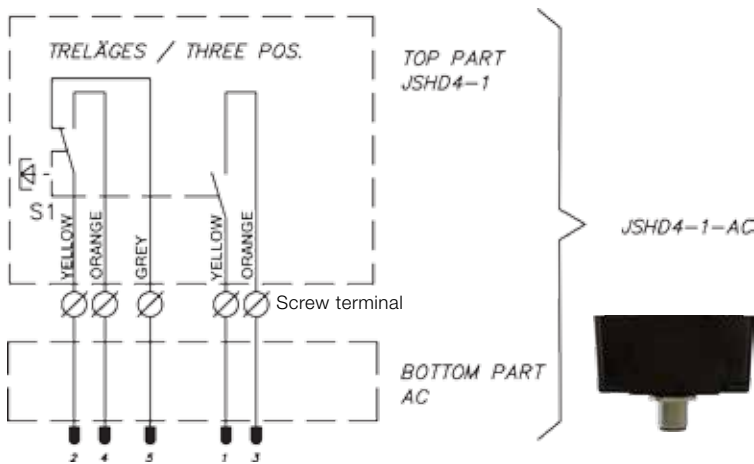

Connection with bottom parts AD

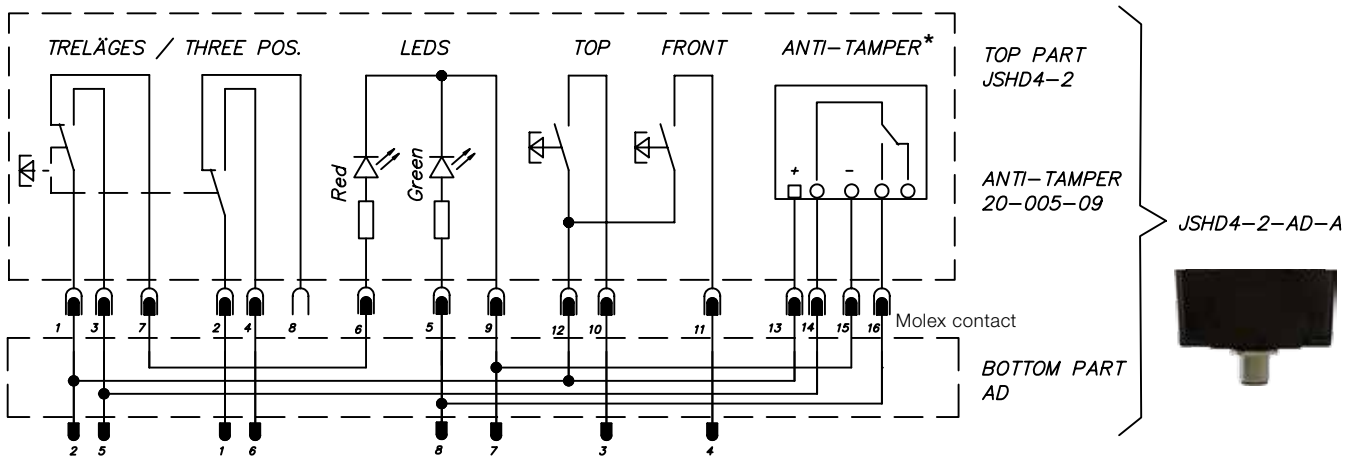

*A jump must be placed over pins 14-16 on the 2x8 Molex connector if an anti-tamper PCB is not used.

Connection with bottom parts AE

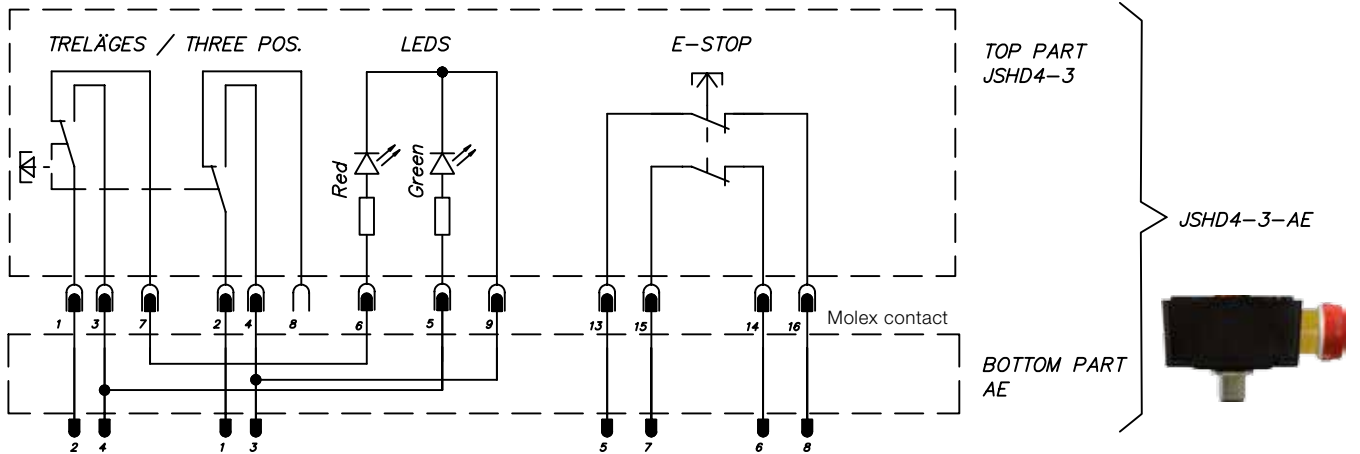

Connection with bottom parts AH

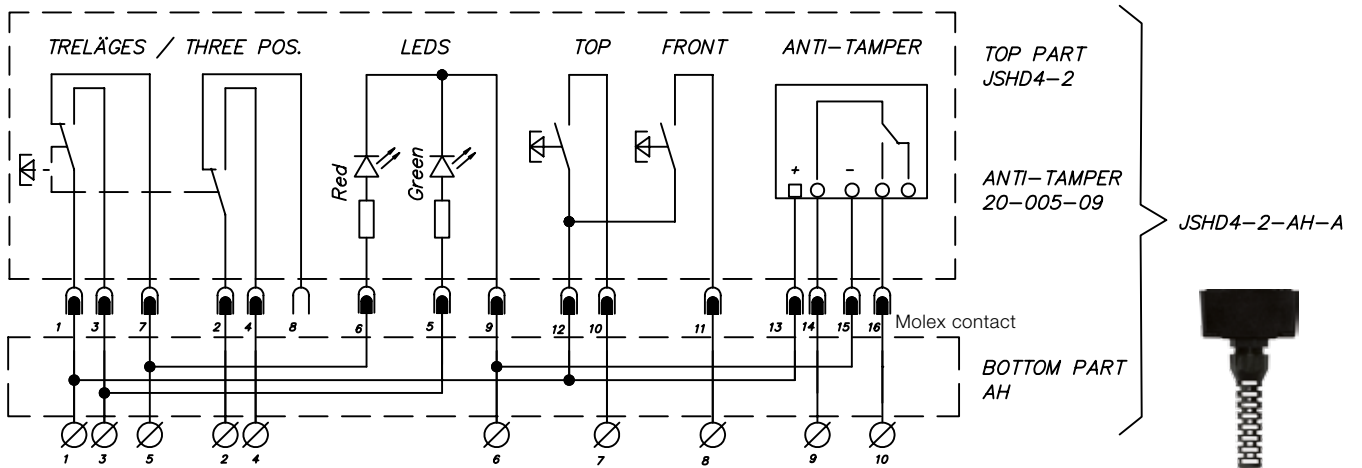

10

Connection with bottom parts AJ

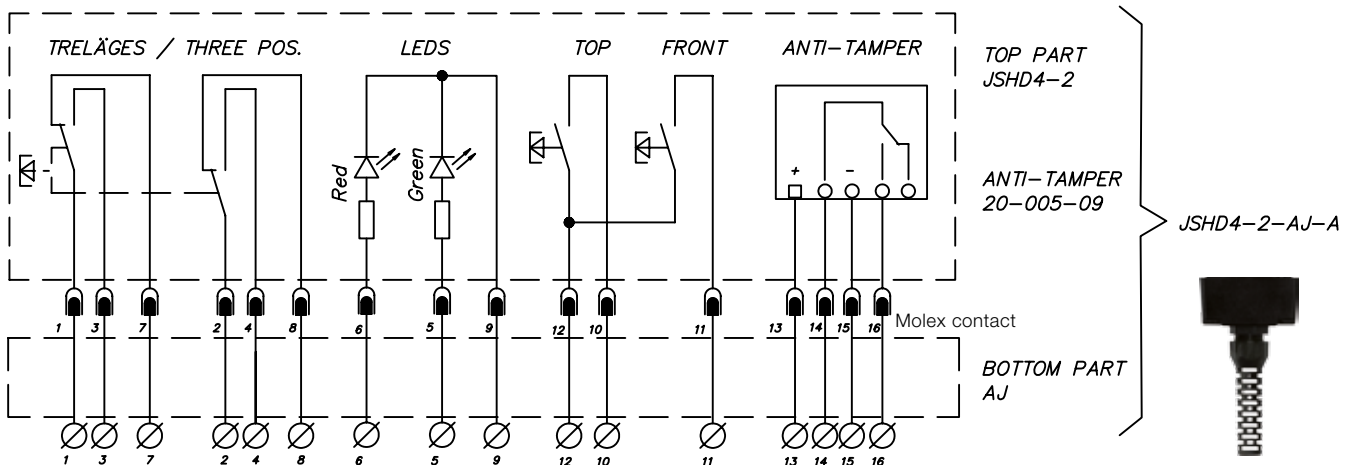

One- and two-hand devices Safeball™



A two-hand device which is comfortable and easy to use.

Approvals:



Safeball for:

- Presses
- Punches
- Fixtures
- Shearing machines

Features:

- Ergonomic
- Low activation force
- Flexible mounting
- Several grip possibilities
- Highest safety level
- Two channel switching in each hand
- Available for AS-i

Safeball™ Unique World Wide Two-hand device

Safeball™ consists of a spherical ball containing two embedded pushbutton switches, one on each side of the ball. By using this pushbutton configuration, the risk of unintentional activation is minimised and the device is simple and ergonomic to use.

Safeball™ can be utilised for either One-hand (one Safeball™) or Two-hand (two Safeballs™) applications. In either application, and in order to meet the required level of safety, the Safeball™ switches are monitored by specified/certified ABB Jokab Safety Safety relays (see electrical connection).

In the case where Two-hand control is used, both Safeballs™ i.e. all four pushbuttons have to be activated within 0.5 seconds. If one or more pushbuttons are released a Stop signal is given to the machine. In order to provide the highest level of safety the Safeball™ design provides the operator with a dual switching function and short-circuit supervision in each hand.

Each Safeball™ is ergonomically designed and has both its cover and actuator made of environmentally-friendly polypropylene. The design allows for comfort of use for all hand sizes and operation from numerous gripping positions. Mounting of the Safeball™ is also very flexible allowing the device to be mounted in the most ergonomic position for the operator.

When can a Two-hand or One-hand control be used?

A Two-hand control can be used when it is necessary to ensure that the operator is outside and must be prevented from reaching into the hazardous area. If the operator decides, after the start signal has been given to the machine, to make an 'after-grasp' i.e. try to adjust the part that has been placed into the machine, then a dual stop signal is given to the machine.

An One-hand control device can be used when the operator cannot reach the hazardous area with his/her free hand or on less dangerous machines.

Highest Safety Level

The Safeball™ is certified by Inspecta in Sweden for use as a Two-hand control device, when used with a JSBR4 ABB Jokab Safety Safety relay or Pluto Safety-PLC, in accordance with the highest safety level in standard EN 574 (type IIIc).

Safeball adapted for AS-i

Safeball also comes in a version adapted for direct attachment to the AS-i bus. For using the safeball AS-i as a Two-hand device the AS-i safety monitor needs to be able to handle simultaneous monitoring of the channels.

Safeball Function

Two-hand control device

The Two-hand control device is implemented by using two Safeballs™, each having two internal pushbuttons. The Safeballs™ must be mounted a minimum distance between each other (see Mounting description).

By utilising two pushbuttons in each device a double safety function is provided in each hand.

The highest safety level is achieved by connecting all four pushbuttons to the ABB Jokab Safety JSBR4 safety relay or Pluto Safety-PLC. The safety relay gives a dual and supervised safety function and requires input activation within 0.5 seconds in order to start the machine. It also checks that all four pushbuttons have returned to their deactivated positions before a new start is allowed. The JSBR4 safety relay also provides a stop signal if one or more pushbuttons are released.

One-hand control device

Safeball™ is also a very practical method of providing a one-hand control device as it is very easy to find and activate by the machine operator. One-hand devices should only be used when the operator cannot reach into the hazardous area with his/her free hand or on less dangerous machines. Before fitting the necessary risk assessment must be made to determine suitability of this type of control. To achieve the highest safety level for One-hand control the Safeball™ must be connected to a safety control system (E.g. safety relay or safety PLC).

Versions

Safeball is available in several versions to meet different mounting requirements.

JSTD1-A - Safeball 1 NO + 1 NC with 2 m cable

JSTD1-B - Safeball 1 NO + 1 NC with 0.2 m cable

JSTD1-C - Safeball 1 NO + 1 NC with 10 m cable

JSTD1-E - Safeball 2 NO 0.2 m cable

JSTD1-G - AS-i Safeball

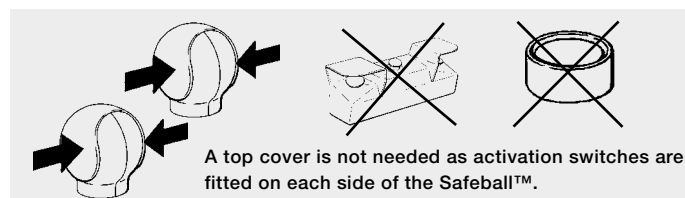
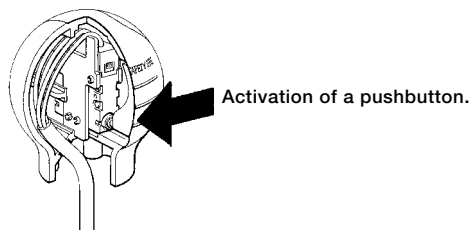

Technical data - Safeball

Article number	JSTD1-A JSTD1-B JSTD1-C JSTD1-E JSTD1-G AS-i	2TLA020007R3000 2TLA020007R3100 2TLA020007R3200 2TLA020007R3400 2TLA020007R3900
Material		Polypropylene
Colour		Yellow and black
Size		Height: approx. 71 mm Diameter, min.: 68 mm Diameter, max.: 72 mm Diameter, base: 42 mm
Weight		0.2 kg with 2 m cable 0.7 kg with 10 m cable 0.1 kg with 4x0.2 m wires
Level of Safety	EN ISO 13849-1	Up to PL e/Cat. 4
Ambient temperature		-25°C to +50°C (operating)
Protection class		IP67. Not intended for use under water
Operating force		Approx. 2 N
Actuator travel		1.3 +/- 0.6 mm
Max switching load		30 V 2A DC, resistive load
Max current (resistive load)		2 A at 30 VDC (max) 20 mA at 24 VDC (recommended)
Min switching load		6V 10mA DC, resistive load
Contact resistance		100 mohm
Life, mechanical		> 1x10 ⁶ operations at max. 1 Hz
Life, electrical		Dependant upon electrical load characteristics
Connection cable	JSTD1-A JSTD1-B, JSTD1-E JSTD1-C JSTD1-G AS-i	2 m PVC-cable, 4 x 0.75mm ² 4 x 0.75 mm ² wires, approx. 0.2 m 10 m PVC-cable, 4 x 0.75 mm ² 2 x 0.75 mm ² wires, approx. 0.25 m
Conformity		EN ISO 12100:2010 EN 574+A1:2008

Chemical resistance at 20°C

Chemical	Resistance
Alcohols	good
Paraffin oil	good
Milk	good
Silicon oil	good
Acetone	good

Please contact us for more information.

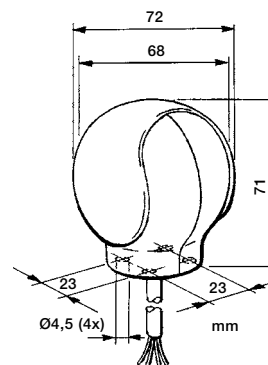

Safeball Mounting

The Safeballs™ can be mounted in many different ways. They can be mounted on a table, a machine, on a support or wherever suitable for ergonomic reasons. The Safeball™ can be mounted in a fixed position or on a tilting and/or rotating support. This flexibility of mounting permits the Safeball™ to be fitted in the best ergonomic position for the ease of operation by the operator. The distance requirement between two Safeballs™ or between a Safeball™ and a wall or edge of a table depends on how the Safeball™ is mounted. Safeball™ can be mounted with four M5 screws or ST4.8 self-tapping screws.

NOTE! When Safeballs™ are mounted in such a way that the distance between them can be adjusted to less than the specified minimum, the mounting screws must be locked to ensure any changes in the distance between the two balls cannot be made.

Approved Two-hand device

To be an approved Two-hand device, both Safeballs™ must be mounted a minimum distance apart in order to prevent operation of both balls with one hand. Safeballs™ must be fitted a minimum distance from the edges of tables or a wall. It is essential that Safeballs™ are correctly installed in order to prevent unintended activation of the devices with part of the body in combination for example with a wall.

Alternative mounting methods

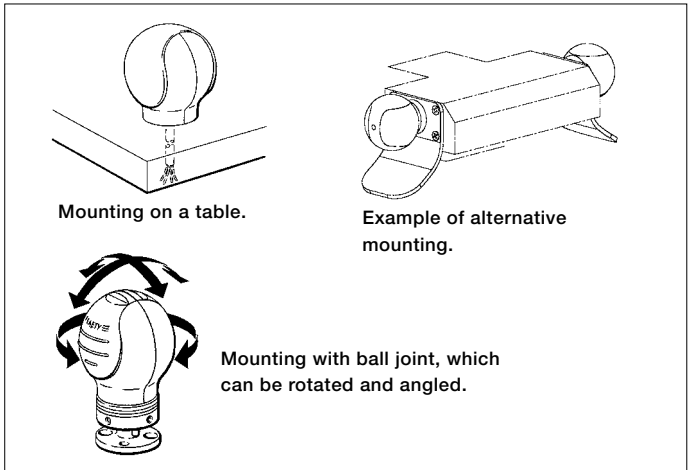

Mounting distance - Safety distance - Safeball

10

Mounting distance

Table mounting of two Safeballs™. In order to prevent cheating the distances shown are the minimum allowed.

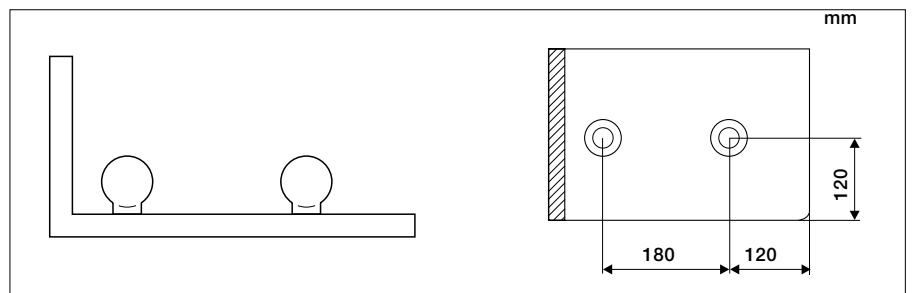

Safety distance

The Safety distance is the distance between the Safeballs™ and the dangerous machine movement. The safety distance requirement can be calculated using the following formula for Safeball™ in accordance with the approving authority and EN ISO 13855: $S = K \times T + C$

Where

- S = safety distance in mm
- K = hand speed, 1600 mm/s
- T = total stopping time for the dangerous movement (including the response time of the safety relays in seconds)
- C = Constant = 0 mm for Safeball.

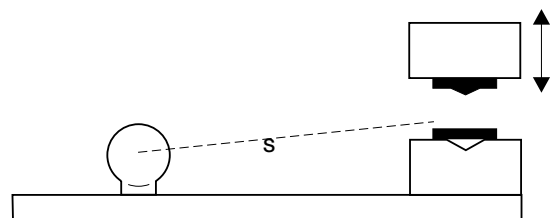

The safety distance is the distance between the Safeballs™ and the dangerous machine movement. Note that S must never be less than 100 mm.

Safeball

Electrical connection

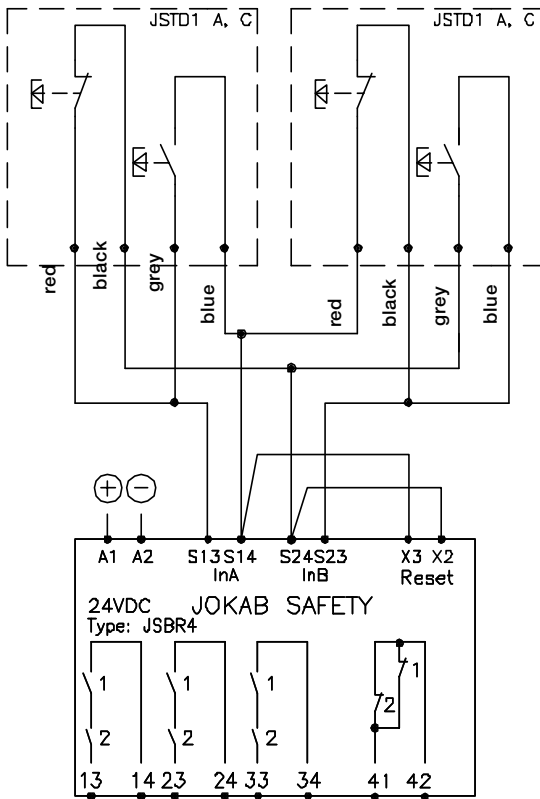

Two-hand device

Safeballs™ are designed to be connected to a ABB Jokab Safety JSBR4 Safety relay or Safety PLC to achieve the highest safety requirements for a Two-hand device.

Example of two devices connected to a ABB Jokab Safety JSBR4 safety relay. Response time on receiving a stop signal from JSTD1 < 15 ms.

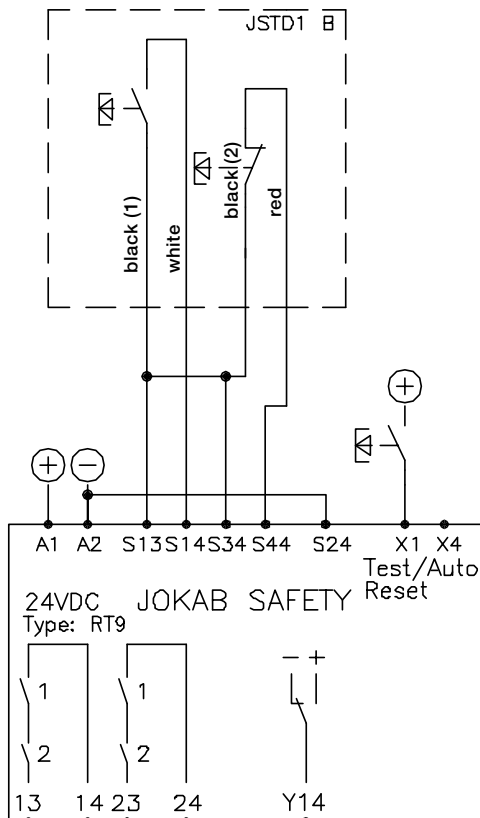

One-hand device

When used as a One-hand device the Safeball™ is designed to be connected to a ABB Jokab Safety RT6, RT7 or RT9 Safety relay in order to achieve the highest possible safety level for this type of control.

Example of a single Safeball™ connected to a ABB Jokab Safety relay RT9. The response time at 'stop' is < 20 ms.

Two-hand control station JSTD25 with Safeball

The JSTD25 replaces the traditional two-hand device. With the JSTD25 control station you have a prepared two-hand unit that is easy to install, while utilizing the good ergonomics of the Safeball. There are several versions to meet differing needs, all versions meet EN 574 and EN ISO 13849-1.

For mobile or fixed installation

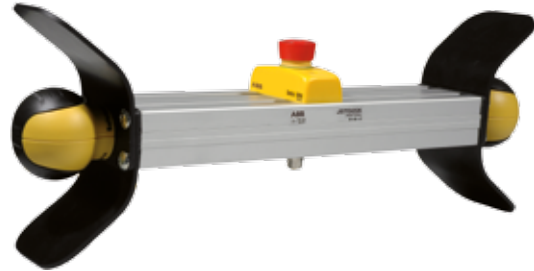

JSTD25F/JSTD25H

Article number - 2TLA020007R6000/2TLA020007R6300

An ergonomic two-hand control unit with two Safeballs mounted on the ends of an aluminum profile. Both Safeballs are protected with shields for unintended press of the Safeball buttons. The device can be easily mounted with the aid of grooves in the aluminum profile and a quick connection is made to the M12 connector underneath the device. For mobile applications with repositioning of the two hand device this unit is very suitable because of its low weight.

JSTD25F is equipped with a 5-pole M12 male connector and the JSHD25H is equipped with an 8-pole M12 male connector.

Both units can be equipped with an external emergency stop (Smile) and an Eden sensor for position control (ordered separately and assembled by the customer).

JSTD25K

Article number - 2TLA020007R6900

The JSTD25K is a fully equipped two-hand control device that is very similar and has all the advantages from the JSTD25F/ JSTD25H.

JSTD25K has just as JSTD25F/H, two Safeballs mounted on the ends of an aluminum profile and the same length. The additional equipment is double protection shields protecting for unintended press from several directions and a Smile 10 EA emergency stop placed on the middle of the profile. Connection is made easily with a 8-pole M12 male connector underneath the device.

10

For mobile installation with a built-in Eden sensor



JSTD25P-1

Article number - 2TLA020007R6500

Two-hand control unit, portable. Two Safeballs mounted on the ends of an aluminium profile, shielded by over hand guards. With built-in Eva sensor for position control. Developed as a portable two-hand device, where the response of the

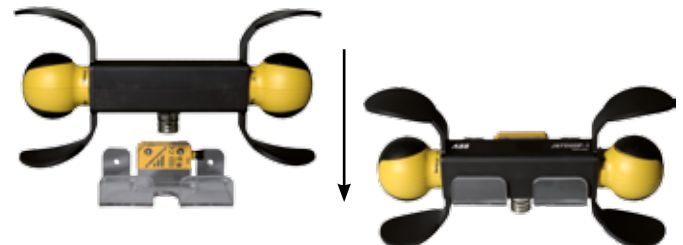

machine to operation can vary at different operating stations, since each station can be connected separately. Connection via an 8+1 Zylin connector.

Accessories

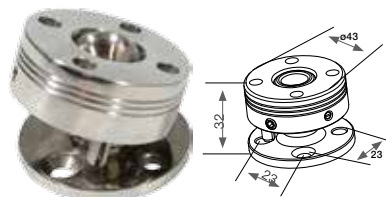

JSM C5

Article number - 2TLA020007R0900
Angled ball joint for installation
of a Safeball on a table or a steel housing.

JSM C7

Article number - 2TLA020007R1200
Suspension shelf for JSTD25F/H/G/K

JSM C14

Article number - 2TLA020007R8000
Suspension shelf for JSTD25P-1



JSTK25S

Article number - 2TLA020007R6700
2.5 m long spiral cable for JSTD25P-1

JSTK50S

Article number - 2TLA020007R6800
8 m long spiral cable for JSTD25P-1

JSTK0-A

Article number - 2TLA020007R6600
Female connector for JSTD25P-1



Safeball protection coat

Article number - 2TLA020007R1900
Extra protection coat for Safeball.

Connection examples

JSTD25F

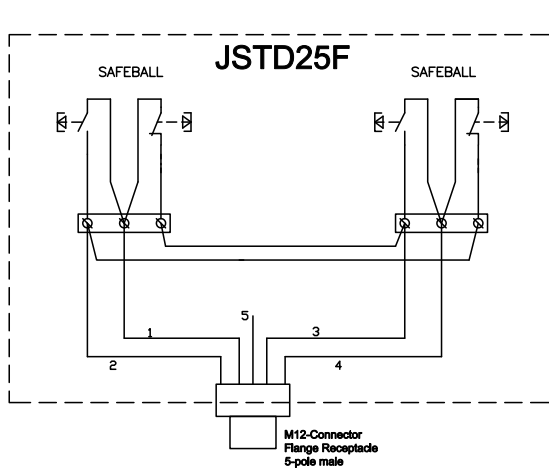

M12 5 Color-code
(not always used, verify!)

- 1 Brun Brown Braun Marron
- 2 Vit White Weiss Blanc
- 3 Blå Blue Blau Bleu
- 4 Svart Black Schwartz Noir
- 5 Not connected

1 Dyn A out
2 Pluto to evaluate A = OK, and test B (two inputs)
3 Pluto to evaluate B = OK, and test A (two inputs)
4 Dyn B out

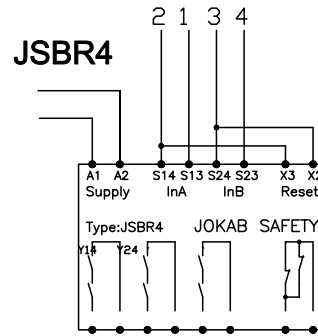

PLUTO

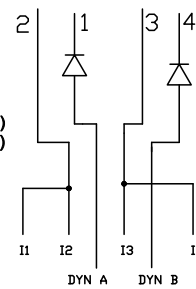

According to standard Pluto Twohand1 block:
I1: Right_NO
I2: Left_NC
I3: Right_NC
I4: Left_NO

JSTD25H

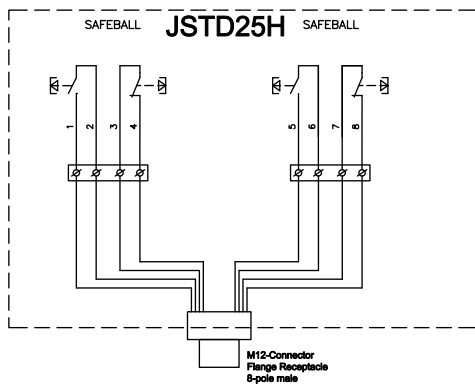

M12-C03
Contact (plug) for self assembly. Female.
As seen from cable side (trace).
Ordered separately.

M12 8 Color-code
(not always used, verify!)

- 1 Vit White Weiss Blanc
- 2 Brun Brown Braun Marron
- 3 Grön Green Grün Vert
- 4 Gul Yellow Gelb Jaune
- 5 Grå Grey Grau Gris
- 6 Rosa Pink Rosa Rose
- 7 Blå Blue Blau Bleu
- 8 Röd Red Rot Rouge

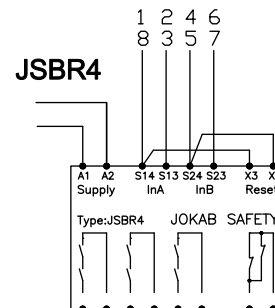
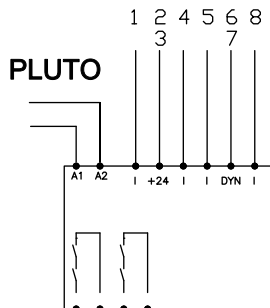

Connection examples

JSTD25P-1

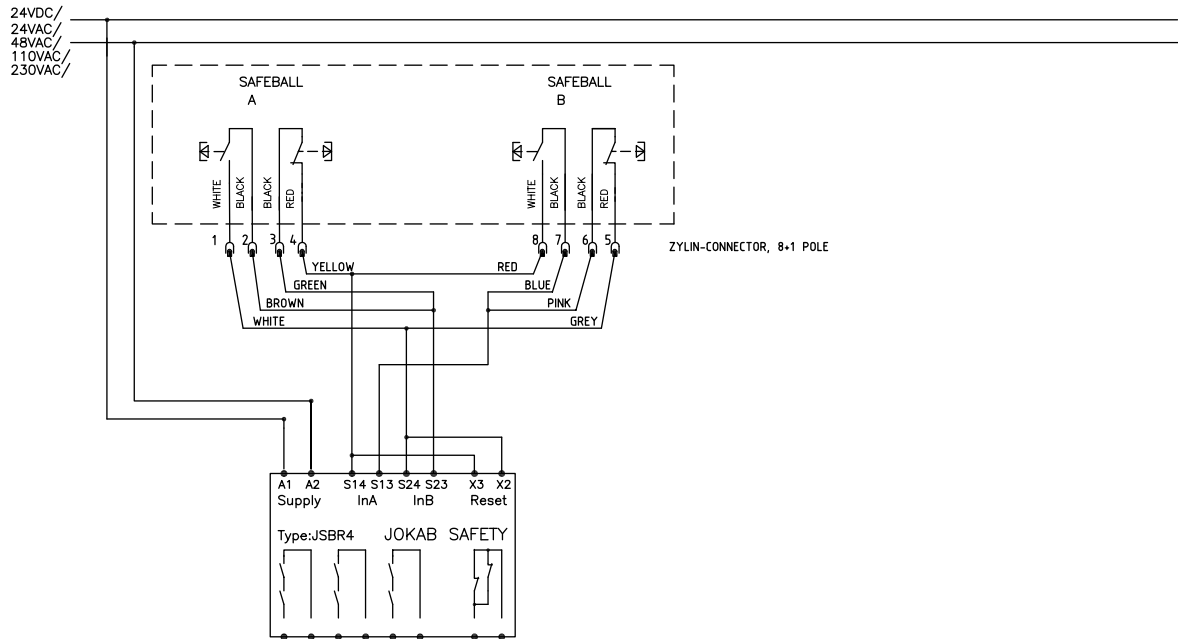

Dimensions

JSTD25

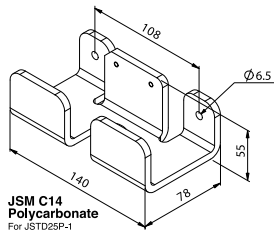
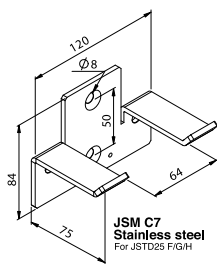

JSTD25F

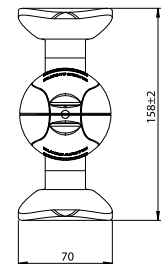
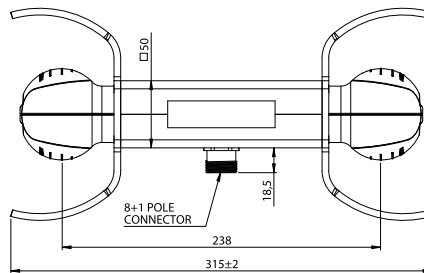
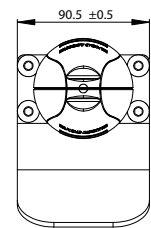
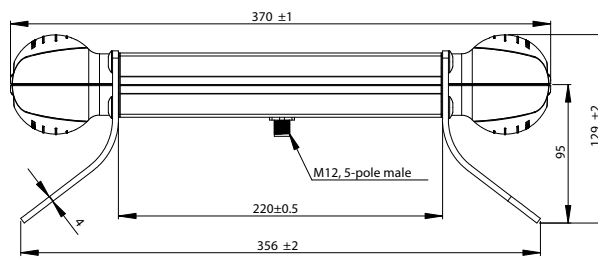

JSTD25P-1

Two-hand device JSTD20



Approvals:



Use:

- Presses
- Punching machines
- Cutting machines
- Fixtures

Features:

- Durable material
- With or without emergency stop pushbutton
- Fulfils requirements of EN 574
- Highest level of safety

Conventional Two-hand device

The conventional JSTD20 Two-hand device utilises a welded steel housing. Two operating pushbuttons are protected by over hand guards. Between these pushbuttons there is space for an emergency pushbutton and two extra controls or indication lamps. Below each of the operating pushbuttons is one normally open and one normally closed contact. To start and run the machine both pushbuttons must be activated within 0.5 seconds. If one or both pushbuttons are released a stop signal is given to the machine, and all contacts must return to their deactivated positions before a new start is allowed.

The design is robust and can withstand harsh environments and long use. The pushbuttons and contact blocks are simple to assemble for quick and easy installation. The device can be mounted directly on the machine, on the ABB Jokab Safety fencing system or on the JSTS30 floor mount. For use with portable Two-hand devices the JSTS31 floor mount, which is provided with a spacer ring to fulfil the requirements of EN 574, is recommended. The JSTD20 is available with or without an emergency stop pushbutton.

Highest level of safety

Correct connection to a ABB Jokab Safety JSBR4 safety relay or Pluto Safety PLC ensures the highest level of safety with dual and supervised safety function and requires input activation of both operating pushbuttons within 0.5 seconds (two hand device type III C in accordance with EN 574). If the emergency pushbutton is installed it should be provided with

two normally closed contacts and be connected to a separate safety relay, e.g. from the RT series or Pluto.

Why use a Two-hand device?

A Two-hand device can be used when it is necessary to ensure that the operator is outside and must be prevented from reaching into the hazardous area. If the operator decides, after the start signal has been given to the machine, to make an 'after grasp' i.e. try to adjust the part that has been placed inside the machine, then a dual stop signal is given to the machine.

The JSTD20 is equipped with a type of large over hand guards in accordance with EN 574. These prevent unintended activation by for instance a knee or elbow.

A Two-hand device only protects the operator using it. Large machines operated by several operators can be equipped with one control for each operator.

To calculate the correct safety distance, which depends on the machine's stopping time including the response time of the relay, the use of the ABB Jokab Safety Smart Stopping analyser is recommended.

Technical data - JSTD20

Article number	
JSTD20A	2TLA020007R2000
JSTD20B	2TLA020007R2100
JSTD20C	2TLA020007R2200
Weight	6.4 Kg
Colour	Black housing, Black pushbuttons, Black floor stand.
Temperature	-10°C...+70°C (Operating) -20°C to +70°C (storage)
Level of Safety	
EN ISO 13849-1	Up to PL e/Cat. 4
Material	
	Housing: 3mm Steel Gasket: Rubber Pushbuttons: Plastic
Operating pushbuttons	
Diameter	60 mm
Operating force	Approx. 9N
Operating distance	3.5±1mm
Mechanical life	10 ⁶ operations
Emergency pushbutton (JSTD20B only)	
Diameter	40 mm
Operating force	40N
Mechanical life	3 x 10 ⁵ operations
Contacts	Mechanically separated contact blocks
Operating pushbuttons	1 NO + 1 NC /button
Emergency pushbuttons	2 x NC
Isolation voltage	690V rms
Contact resistance	20 mohm
Rated current	10A

Utilisation categories	
	AC 15 240V 3A DC 13 240V 0.27A
Cabling	
	screw clamp terminals, 1 or 2 wires with max. cross-section 2.5 mm ² .
Contact material	silver alloy on brass
Protection class	IP65
Accessories	
JSTS30 floor stand	2TLA020007R4000
JSTS31 floor stand + distance ring	2TLA020007R4100
JSTS32 distance ring	2TLA020007R4200
Conformity	
	EN ISO 13850, EN IEC 60947-5-5, EN 574+A1:2008, EN 12100:2010, EN ISO 13849-1, EN 60947-1, EN 60947-5-1, EN ISO 12855

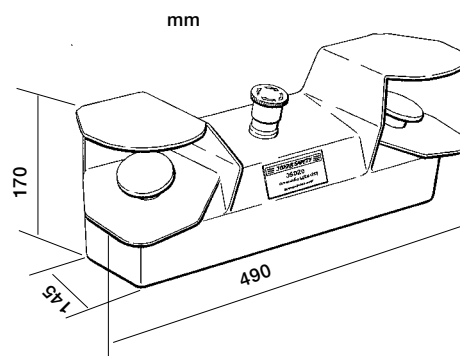

JSTD20A – Two-hand device, without emergency stop

JSTD20B – Two-hand device, with emergency stop

JSTD20C – Only housing, no buttons

Connection example - JSTD20

The Two-hand device is intended for use with ABB Jokab Safety's JSBR4 safety relay (or Pluto Safety PLC) to ensure the highest level of safety. The JSBR4 ensures that all contacts have returned to their deactivated positions before a new start is allowed. The safety relay also requires that all contacts are activated within 0.5 seconds. The JSBR4 gives a stop signal if one or both of the pushbuttons are released.

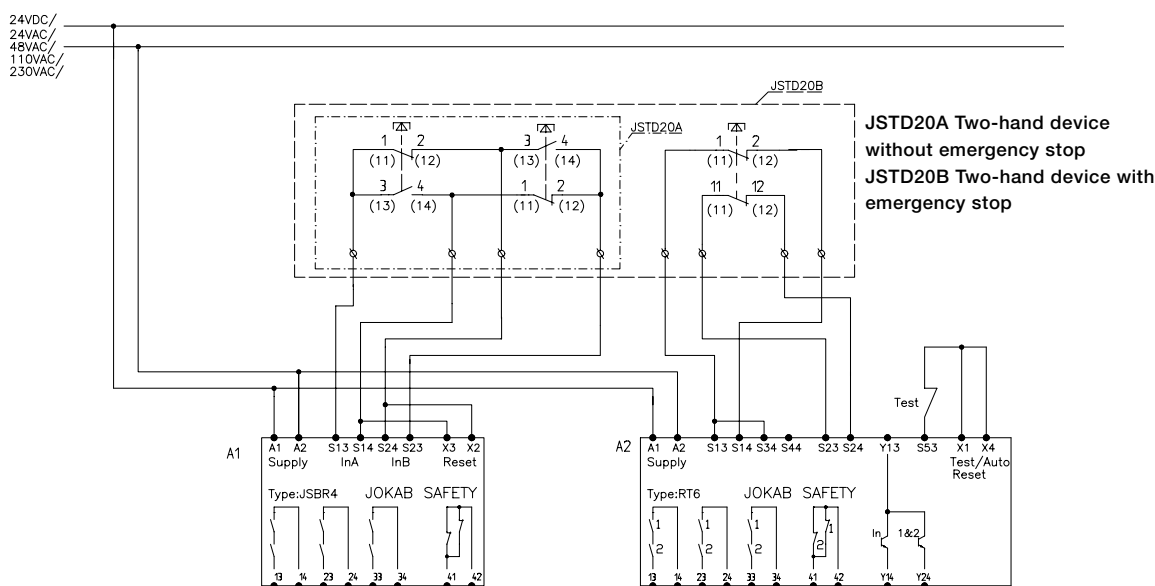



Emergency stops and Safety stops

Why do you need an Emergency stop? 11/3

Emergency stop

For enclosure installation - INCA 1	11/4
For enclosure installation - INCA 1 Tina	11/5
With indication - Smile	11/7
With indication - Smile Tlna	11/11
With indication - Smile AS-i	11/15
Compact	11/17
EStrongZ	11/19

Other buttons

Safety stop - INCA, Smile and Compact	11/21
Reset button - Smile 11 R	11/22

Emergency Stop Grab Wire

Emergency Stop Grab Wire Safety Switches	11/23
LineStrong1	11/25
LineStrong2	11/27
LineStrong3	11/29
Accessories	11/33

Why do you need an Emergency stop?

– so that anyone shall be able to stop a machine during a machine break-down or if someone is in danger.

How do I recognise an E-stop?

E-stop buttons shall according to relevant standards be red with a yellow background. An emergency stop grab wire shall be red for high visibility. A sign that indicates the location of the E-stop shall be green with a white picture and possibly with text in the local country's language.



How shall an E-stop stop the machine?

An E-stop shall stop the machine as quickly as possible. To obtain a quick stop one either removes the power directly or one lets a frequency converter 'run down' and afterwards after a little delay, remove the power. An E-stop shall not create other hazards. Therefore a risk analysis must be made for the E-stop to be correctly connected.

From 2006/42/EC, clause 1.2.4.3

...

This device must:

- have clearly identifiable, clearly visible and quickly accessible control devices,
- stop the hazardous process as quickly as possible, without creating additional risks,
- where necessary, trigger or permit the triggering of certain safeguard movements.

...

11

Requirements for E-stops are stated in the following standards and regulations

2006/42/EC The Machinery Directive

Clause 1.2.4.3 in Annex 1 gives requirements for the emergency stop function for new machines). See also clause 1.2.2 Control devices. (see chapter "Standard and Regulations")

Council Directive 89/655/EEC (with amendments) concerning the minimum safety and health requirements for the use of work equipment by workers at work

Clause 2.4 gives the requirements for the emergency stop function for older machines. See also clause 2.1. (see chapter "Standard and Regulations")

EN ISO 13850 Safety of machinery – Emergency stop – Principles for design

A harmonized standard that gives technical specifications for the requirements in the Machinery Directive. Could also be used for older machinery.

EN 60204-1 Safety of Machinery - Electrical equipment of machines – Part 1: General requirements.

Harmonized standard that gives requirements for the electrical equipment of machinery including the emergency stop actuator/function. See clauses 9.2.2 and 9.2.5.4.2.

Emergency stop for enclosure installation INCA 1

Approvals:



Application:

- To stop a machine or a process

Features:

- Terminal blocks
- Emergency push button up to PL e/Cat. 4 acc. to EN ISO 13849-1
- Only 53 mm construction depth
- With LED info in push button
- Push button IP65, connector IP20
- Available as safety stop (black push button)



Description

INCA 1 is an emergency stop designed for installation in 22.5 mm holes on cabinets. INCA 1 has potential free contacts for connection to safety relays. The connection is made in cabinets via a removable terminal which also have excellent measuring points. Inca 1 is also available with a black pushbutton and used as a safety stop. See section on Safety stops.

In the emergency stop button there is a LED that displays current status on:

- Green = everything ok
- Red = this emergency push button has been pressed
- Off = a unit earlier in the circuit is affected

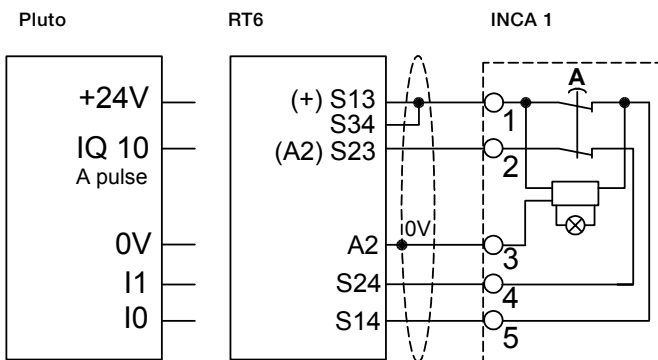

INCA 1S. See more information on section - Safety stop.

Emergency stop for enclosure installation INCA 1 Tina

Approvals:



Application:

- To stop a machine or a process

Features:

- Terminal blocks
- Emergency push button up to PL e/Cat. 4 acc. to EN ISO 13849-1
- Only 53 construction depth
- With LED info in push button
- Info output (INCA 1 Tina)
- Push button IP65, connector IP20
- Available as safety stop (black push button)



Description

INCA 1 Tina is an emergency stop designed for installation in 22.5 mm holes in equipment cabinets. In addition to the INCA 1 version, INCA 1 Tina is adjusted to work in dynamic safety circuits for connection to the safety relay Vital and safety PLC Pluto units. The connection is made in equipment cabinets via a removable terminal block which also has marked measuring points. Inca 1 Tina is also available with black push button and is used in this case as a safety stop. See section on safety stops.

The emergency stop button has a LED that displays the current status:

- Green = everything is OK
- Red = this emergency stop has been pressed.
- Flashing red/green = a protection device earlier in the circuit has been actuated.

11

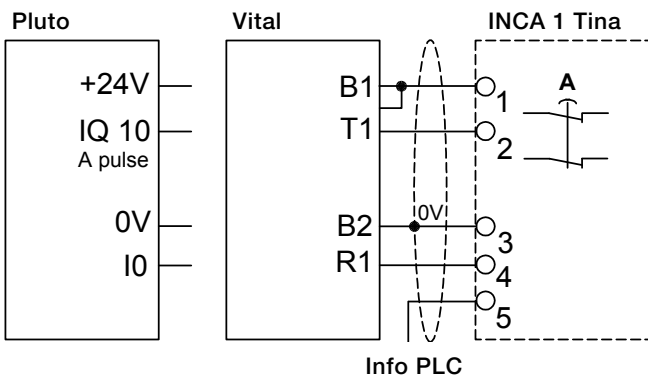

INCA 1S Tina. See more information on section - Safety stop.

Technical data - INCA 1/INCA 1 Tina

Article number	
INCA 1	2TLA030054R0100
INCA 1 Tina	2TLA030054R0000
Impact resistance (half sinusoidal)	Max. 150m/s ² , pulse width 11 ms, 3-axis, acc. to EN IEC 60068-2-27
Vibration resistance (sinusoidal)	Max. 50 m/s ² at 10 Hz...500 Hz, 10 cycles, 3 axis, acc. to EN IEC 60068-2-6
Climate resistance	
Damp heat, cyclical	96 hours, +25 °C / 97%, +55 °C / 93 % relative humidity, as per EN IEC 60068-2-30
Damp heat, sustained	56 days, +40 °C / 93 % relative humidity, as per EN IEC 60068-2-78
Dry heat	96 hours, +70 °C, as per EN IEC 60068-2-2
Cooling	96 hours, -40 °C, as per EN IEC 60068-2-1
Salt mist	96 hours, +35 °C in a chemical solution with NaCl as per EN IEC 60068-2-11
Level of safety	
EN ISO 13849-1	Up to PL e/Cat. 4 depending upon system architecture
EN 62061	SIL 3 depending upon system architecture
IEC/EN 61508-1...7	SIL 3
PFH _D	
INCA 1	PFH _D : 1.60×10 ⁻¹⁰
INCA 1 Tina	PFH _D : 4.66×10 ⁻⁹
Colour	Yellow, red and black
Weight	Approx. 45 grams
Size	See drawing
Material	Polyamide PA66, Macromelt, Polybutylenterephthalate PBT UL 94 V0
Temperature	-10°C to +55°C (operation), -30°C to +70°C (storage)
Protection class	Button: IP65, Connector: IP20
Installation	22.5 mm
Emergency stop LEDs	INCA 1: Green: Safety device OK. Not lit: A unit earlier in the circuit is affected. Red: This emergency stop has been pressed. INCA 1 Tina: Green: Safety device OK, safety circuit OK Flashing: Safety device OK, safety circuit previously interrupted. Red: This button is pressed in, and the safety circuit is interrupted.
Operating voltage (LED)	INCA 1: 24 VDC INCA 1 Tina: 24 VDC +15% -25%

Current consumption (LED)	INCA 1: 15 mA INCA 1 Tina: 47 mA
Actuating force	22 ± 4 N
Operating movement	Approx. 4 mm to locked position
Contact material	Gold-plated silver alloy
Minimum current	INCA 1: 10 mA, 10 VDC/10 VAC INCA 1 Tina: —
Maximum current	INCA 1: 2 A 24 VDC INCA 1 Tina: —
Mechanical life	> 50 000 operations
Accessories	
Front ring yellow for INCA	2TLA030054R0400
Emergency Stop Sign S DK FIN, 22.5 mm	2TLA030054R0500
Emergency Stop Sign EN F D, 22.5 mm	2TLA030054R0600
Emergency Stop Sign (blank) 22.5 mm	2TLA030054R0900
Conformity	EN ISO 12100:2010 EN ISO 13849-1:2008 EN 62061:2005 EN 60204-1:2006+A1:2009 IEC 60664-1:2007 EN 61000-6-2:2005 EN 61000-6-4:2007 EN 60947-5-5:2005 EN ISO 13850:2006



Yellow front ring and emergency stop signs for emergency stop.

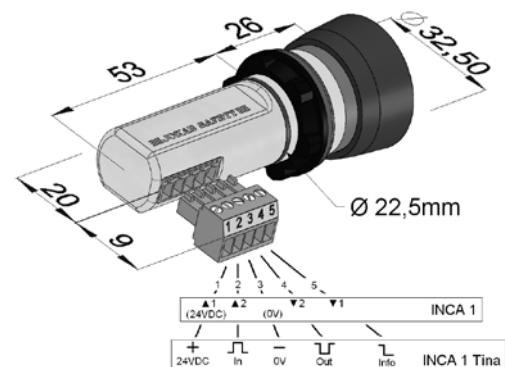

Emergency stop with indication Smile



Approvals:



Application:

- To stop a machine or a process

Features:

- Emergency push button up to PL e/Cat. 4 acc. to EN ISO 13849-1
- With LED info in push button
- Robust
- IP65
- Available as safety stop (black push button)
- Available for AS-i

Smile - small and cost effective E-stop

In order to fulfill the need for a small and easy to install E-stop, Smile has been developed. The size of the device makes it possible to be installed wherever you want. With M12 connection/s or cable and centralised mounting holes Smile is very easy to install, especially on aluminium extrusions. Smile is available for E-stops in both dynamic and static safety circuits i.e. for interfacing to Vital/Pluto and Safety relays. Each version is available with either one or two M12 connections or cable. At the top of Smile, a LED shows the current status as: green = protection OK, red = this emergency stop has been pressed and if the LED is off, an emergency stop earlier in the circuit has been actuated. Smile is also available with black push button and is used as a safety stop. See section on safety stops.

Smile emergency stop comes in five different versions:

1. Smile 10 EA has a 1 m cable connected through the base of the unit.
2. Smile 10 EK has four 1 m connecting leads through the base of the unit. No LED.
3. Smile 11 EA has a 5-pole M12 connector on one end of the unit.
4. Smile 12 EA has two 5-pole M12 connectors, one on each end of the unit.
5. Smile 11 EAR has one 5-pole M12 connector at one end of the unit.

Smile 11 EA adapted for AS-i

The Smile 11 EA also comes in a version adapted for direct attachment to the AS-i bus.

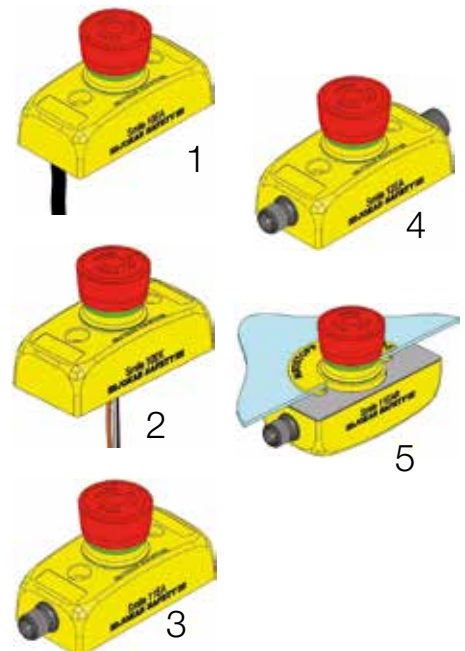

Smile

Connection examples

Smile 10 EA connected to either Pluto or a safety relay with LED indication. The connection cable exits from underneath.

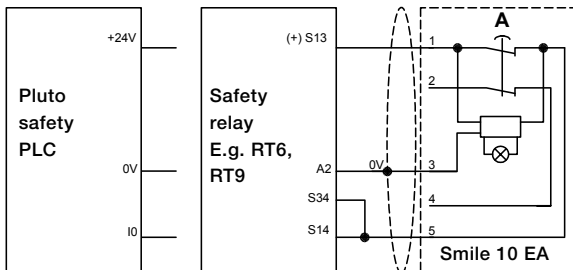

Single channel - Safety category 1.

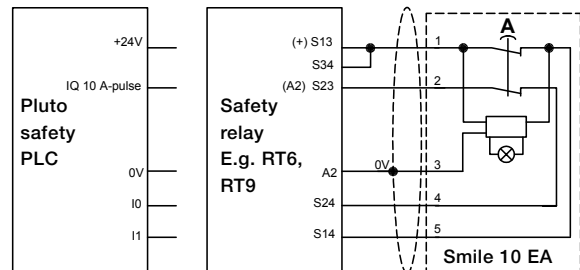

Dual channel - Safety category 4.

Smile 11 EA connected to either Pluto or a safety relay with LED indication. Connection via M12 connector.

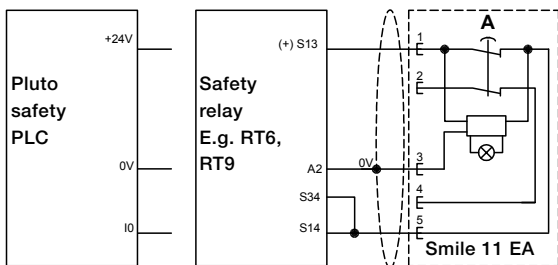

Single channel - Safety category 1.

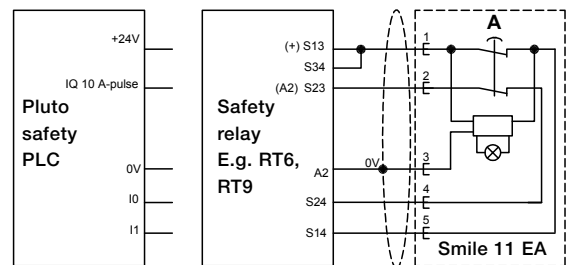

Dual channel - Safety category 4.

Smile 12 EA connected to either Pluto or a safety relay with LED indication. Connection via M12 connector + termination.

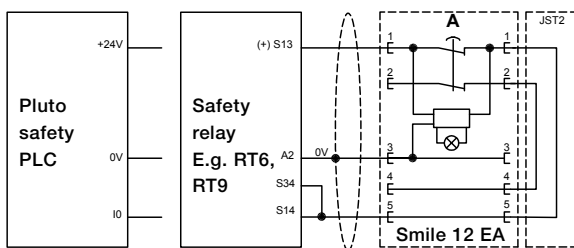

Single channel - Safety category 1.

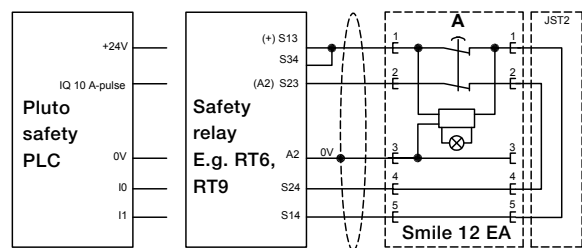

Dual channel - Safety category 4.

Smile 10 EA / 11 EA / 12 EA connected to either Pluto or a safety relay **without** LED indication.

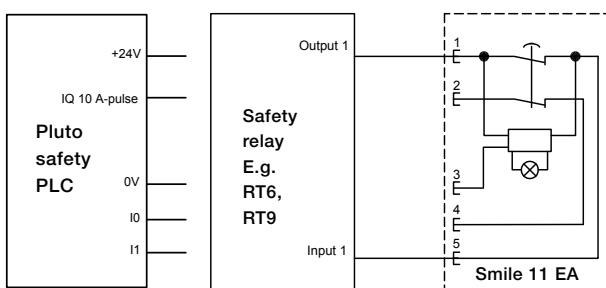

Single channel - Safety category 1.

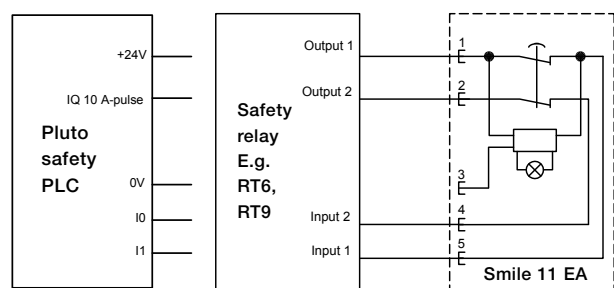

Dual channel - Safety category 4.

Smile

Connection examples

Smile 12 EA connected to either Pluto or a safety relay with LED indication. Connection via M12 connectors. Reconnection to the Pluto/safety relay is made via a separate cable. You can also use JST2 as a termination device after Smile12EA (C).

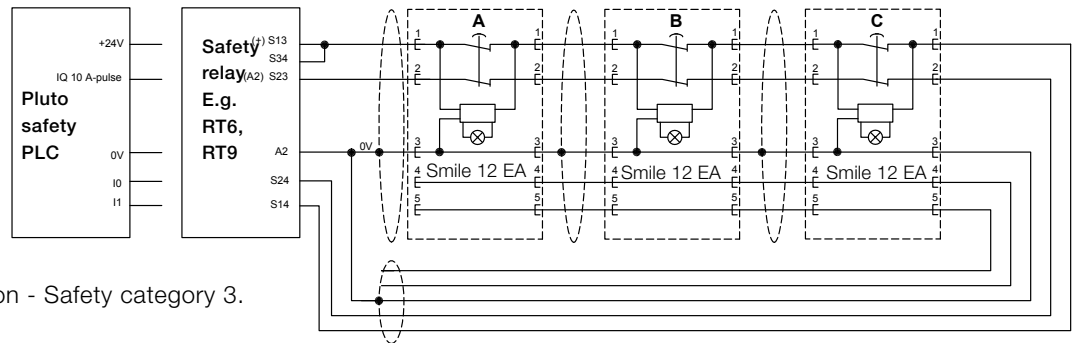

Dual channel series connection - Safety category 3.

Smile 12 EA and 11 EA connected to either Pluto or safety relay with LED indication. Connection via M12 connectors. Note that there is no termination connector as the Smile 11EA (C) completes the circuit without the need for a termination connector (JST2) or return cable.

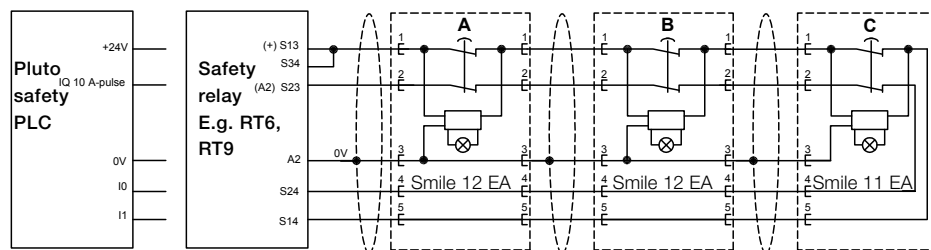

Dual channel series connection - Safety category 3.

LED Indication for the connection example above, where two Smile 12 EA and one Smile 11 EA are connected in series, is shown in the following table (applies for all Smile).

A = Smile 12EA
B = Smile 12EA
C = Smile 11EA

R = Released
P = Pressed
G = Green light
Rd = Red light
B = Blank, no light

E-Stop Button status				LED Indication		
A	B	C		A	B	C
R	R	R	↔	G	G	G
R	R	P	↔	G	G	Rd
R	P	R	↔	G	Rd	B
R	P	P	↔	G	Rd	B
P	R	R	↔	Rd	B	B
P	R	P	↔	Rd	B	B
P	P	R	↔	Rd	B	B
P	P	P	↔	Rd	B	B

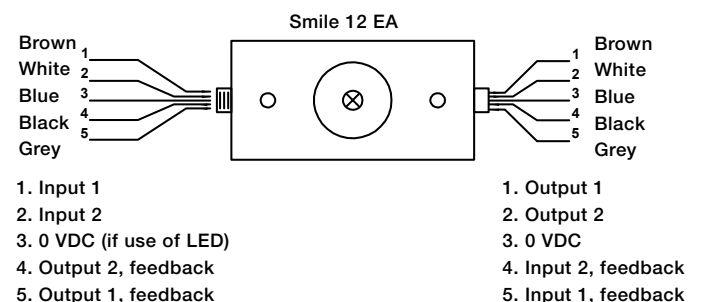
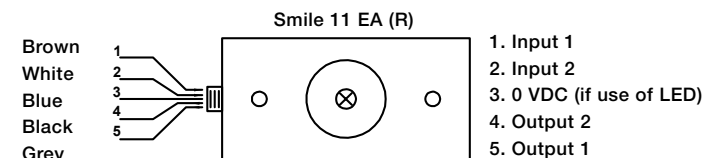
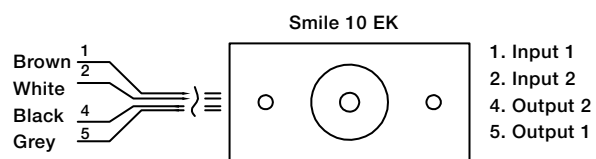
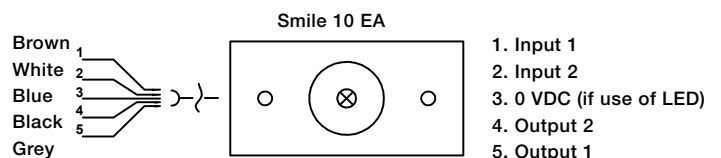

Technical data – Smile

Article number	
Smile 10 EA	2TLA030051R0400
Smile 10 EK	2TLA030051R0600
Smile 11 EA	2TLA030051R0000
Smile 12 EA	2TLA030051R0200
Smile 11 EAR	2TLA030051R0100
Smile 11 EA AS-i	2TLA030052R0000
Note. There are other versions for dynamic technology (with Tina).	
Impact resistance (half sinusoidal)	max. 150 m/s ² , pulse width 11 ms, 3-axis, as per EN IEC 60068-2-27
Vibration resistance (sinusoidal)	max. 50 m/s ² at 10 Hz, 10 cycles, 3-axis, as per EN IEC 60068-2-6
Climate resistance	
Damp heat, cyclical	96 hours, +25 °C / 97%, +55 °C / 93 % relative humidity, as per EN IEC 60068-2-30
Damp heat, sustained	56 days, +40 °C / 93 % relative humidity, as per EN IEC 60068-2-78
Dry heat	96 hours, +70 °C, as per EN IEC 60068-2-2
Cooling	96 hours, -40 °C, as per EN IEC 60068-2-1
Salt mist	96 hours, +35 °C in a chemical solution with NaCl as per EN IEC 60068-2-11
Level of safety	
EN ISO 13849-1	Up to PL e/Cat. 4 depending upon system architecture
EN 62061	SIL 3 depending upon system architecture
IEC/EN 61508-1...7	SIL 3
PFH₀	1.60E-10
Colour	Yellow, red and black
Weight	Approx. 65 grams
Size	Length: 84 mm + M12 contact(s) (12.5 mm each) Width: 40 mm Height: 52 mm
Material	Polyamide PA66, Macromelt, Polybutylenterephthalate PBT, Polypropylene PP, UL 94 V0
Ambient temperature	-10°C to +55°C (operation), -30°C to +70°C (stock)
Protection class	IP65
Actuating force	22 ± 4 N
Actuator travel	Approx. 4 mm to latch
Mechanical life	> 50 000 operations
Mounting	Two M5 recessed hexagon head screws, L ≥25 mm. Hole cc: 44 mm

LED on E-Stop	Green: Safety device OK, Safety circuit OK Off: Safety circuit is previously interrupted. (When an E-Stop is depressed all following units in the circuit lose the LED function). Red: This button is pressed, and the safety circuit is interrupted.
Operating voltage (LED)	17-27 VDC ripple ±10% (LED supply voltage)
Current consumption (LED)	15 mA
Material, contacts	Silver alloy gold plated
Min current	10 mA 10 VDC/ 10 VAC
Max current	2 A 24 VDC
Accessories	
Emergency Stop Sign S DK FIN, 32.5 mm	2TLA030054R0700
Emergency Stop Sign EN F D, 32.5 mm	2TLA030054R0800
Emergency Stop Sign (blank) 32.5 mm	2TLA030054R1000
JST2 termination for Smile 12	2TLA030051R1300
Smile side shield	2TLA030054R1100
Conformity	EN ISO 12100:2010, EN ISO 13849-1:2008, EN 62061:2005, IEC 60664-1:2007 EN 60204-1:2006+A1:2009, EN 61000-6-2:2005, EN 61000-6-4:2007, EN 60947-5-5:2005, EN ISO 13850:2006



Sign for emergency stop



Smile side shield



Termination device JST2

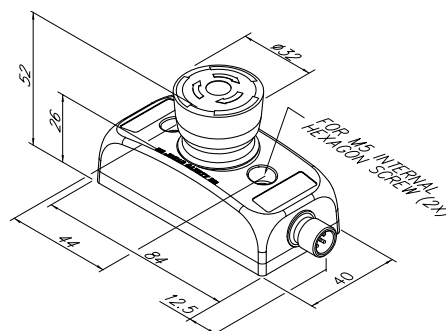

Emergency stop with indication Smile Tina



Smile Tina - small and cost effective E-stop

In order to fulfill the need for a small and easy to install E-stop, Smile has been developed. The size of the device makes it possible to be installed wherever you want. With M12 connections or cable and centralised mounting holes Smile is very easy to install, especially on aluminium extrusions. Smile is available for E-stops in both dynamic and static safety circuits i.e. for interfacing to Vital system/Pluto safety PLC and Safety relays. Each version is available with either one or two M12 connections or cable. Two M12 connectors are used to enable the connection of E-stops in series, which is often used with dynamic safety circuits fulfilling safety category 4. In the top of the Smile Tina E-stop unit, LEDs show the actual status according to the dynamic system:

Green = everything is OK

Red = E-stop activated.

Flashing Red/Green = Stop activated from another preceding device.

Smile is also available with black push button and used as a safety stop. See section on safety stops.

The Smile Tina emergency stop is available in four versions:

1. Smile 10 EA Tina has a 1 m cable connected via the base of the unit.
2. Smile 11 EA Tina has a 5-pole M12 connector on the end of the unit.
3. Smile 12 EA Tina has two 5-pole M12 connectors, one on each end of the unit.
4. Smile 11 EAR Tina has one 5-pole M12 connector at one end of the unit.

Approvals:



Application:

- To stop a machine or a process

Features:

- Emergency push button up to PL e/Cat. 4 acc. to EN ISO 13849-1
- Light grids, emergency stop and Eden in the same safety circuit together with Vital or Pluto gives PL e/Cat. 4 acc. to EN ISO 13849-1
- With LED indication on push button
- Robust
- Info-signal from each emergency stop
- IP65
- Available as safety stop (black push button)

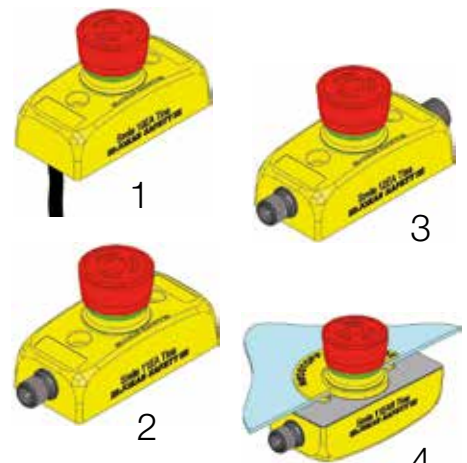

Smile Tina

Connection examples

Smile 10 EA Tina connected to either a Pluto or Vital system with LED indication/information. The connection cable exits from underneath the unit. Safety circuit category 4.

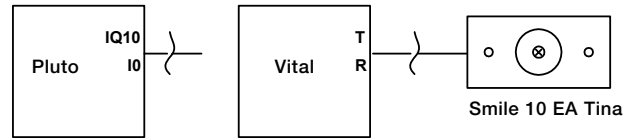

Smile 11 EA Tina connected to either a Pluto or Vital system with LED indication/information. Three Smile 11 EA Tina units connected via M12 connectors in a serie via connection terminals in the electrical cabinet. Safety circuit category 4.

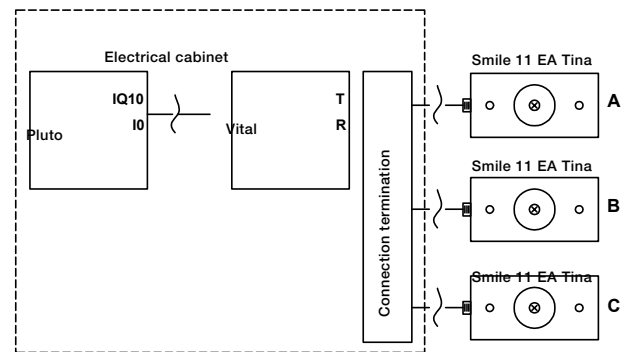

Smile 11 EA Tina connected to either a Pluto or Vital system with LED indication/information. Three Smile 11 EA Tina units and one Eden connected via M12 connectors in a serie via a Tina 4A connection block. Safety circuit category 4.

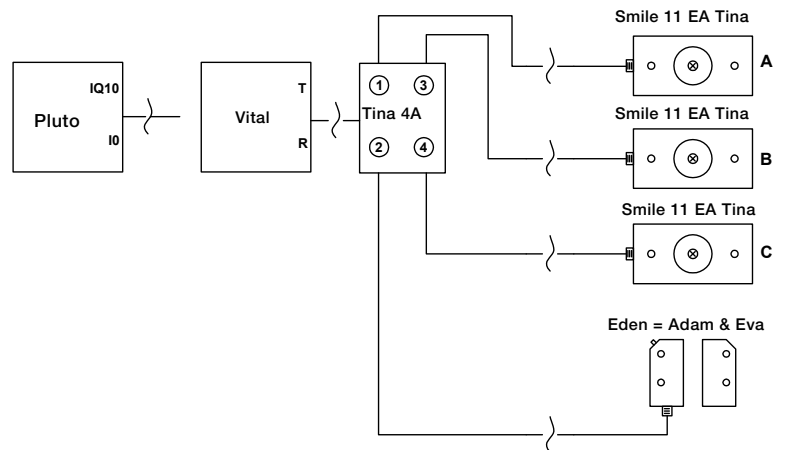

Smile 12 EA Tina connected to either a Pluto or Vital system with LED indication/information. Two Smile 12 EA Tina's, one Eden sensor and one Focus Light Curtain connected via M12 connectors in a serie. Safety circuit category 4.

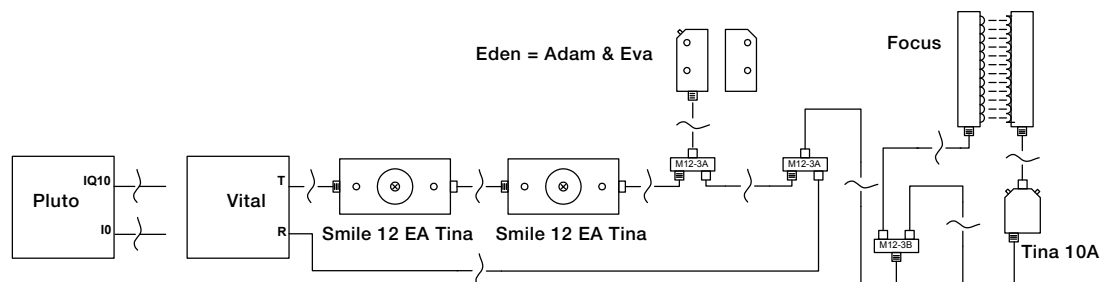

Smile Tina

Connection examples

Smile 12 EA Tina connected to either a Pluto or Vital system with LED indication/information. Three Smile 12 EA Tina units connected via M12 connectors in a serie. Reconnection to the Pluto/safety relay is made via a separate cable. Safety circuit category 4.

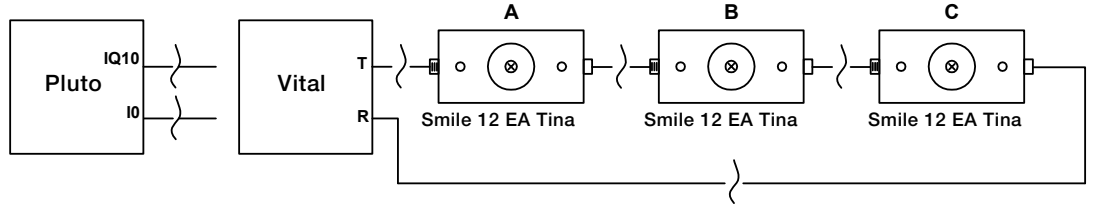

E-Stop Button status				LED Indication		
A	B	C		A	B	C
R	R	R	↔	G	G	G
R	R	P	↔	G	G	Rd
R	P	R	↔	G	Rd	F
R	P	P	↔	G	Rd	Rd
P	R	R	↔	Rd	F	F
P	R	P	↔	Rd	F	Rd
P	P	R	↔	Rd	Rd	F
P	P	P	↔	Rd	Rd	Rd

LED Indication for the connection example above, where three Smile 12 EA Tina units are connected in series, is showed in the following table (applies for all Smile Tina).

- | | |
|----------------------|--|
| A = Smile 12 EA Tina | R = Released |
| B = Smile 12 EA Tina | P = Pressed |
| C = Smile 12 EA Tina | G = Green light |
| | Rd = Red light |
| | F = Flashes, changing between red and green light. |

E-Stop Button status				Information output signal		
A	B	C		A	B	C
R	R	R	↔	H	H	H
R	R	P	↔	H	H	L
R	P	R	↔	H	L	H
R	P	P	↔	H	L	L
P	R	R	↔	L	H	H
P	R	P	↔	L	H	L
P	P	R	↔	L	L	H
P	P	P	↔	L	L	L

Information output signal for the connection example above, where three Smile 12 EA Tina units are connected in series, is showed in the following table (applies for all Smile Tina). The status information signal can be connected to e.g. PLC input. **Note.** The information signal must not be used as a safety signal. The signal should only be used to indicate the status of connected devices.

- | | |
|----------------------|--------------------------------|
| A = Smile 12 EA Tina | R = Released |
| B = Smile 12 EA Tina | P = Pressed |
| C = Smile 12 EA Tina | H = High (i.e. supply voltage) |
| | L = Low (= 0 VDC) |

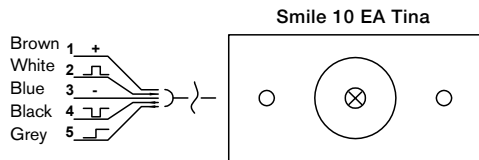

1. Input voltage, 17-27 VDC ripple +/- 10%
2. Dynamic input signal
3. 0 VDC
4. Dynamic output signal
5. Information output

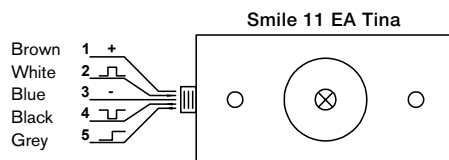

1. Input voltage, 17-27 VDC ripple +/- 10%
2. Dynamic input signal
3. 0 VDC
4. Dynamic output signal
5. Information output

1. Input voltage, 17-27 VDC ripple +/- 10%
2. Dynamic input signal
3. 0 VDC
4. Not used
5. Not used

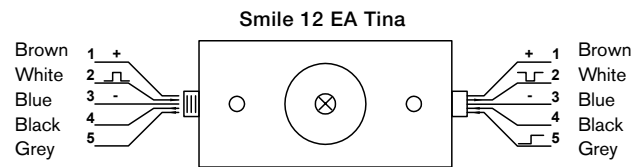

1. Output voltage to next unit
2. Dynamic output signal (To next Smile or to Pluto or Vital system)
3. 0 VDC
4. Not used
5. Information output

Technical data – Smile Tina

Article number	
Smile 10 EA Tina	2TLA030050R0400
Smile 11 EA Tina	2TLA030050R0000
Smile 12 EA Tina	2TLA030050R0200
Smile 11 EAR Tina	2TLA030050R0100
Note. There are versions for use with relay technology (without Tina).	
Impact resistance (half sinusoidal)	max. 150 m/s ² , pulse width 11 ms, 3-axis, as per EN IEC 60068-2-27
Vibration resistance (sinusoidal)	max. 50 m/s ² at 10 Hz, 10 cycles, 3-axis, as per EN IEC 60068-2-6
Climate resistance	
Damp heat, cyclical	96 hours, +25 °C / 97%, +55 °C / 93 % relative humidity, as per EN IEC 60068-2-30
Damp heat, sustained	56 days, +40 °C / 93 % relative humidity, as per EN IEC 60068-2-78
Dry heat	96 hours, +70 °C, as per EN IEC 60068-2-2
Cooling	96 hours, -40 °C, as per EN IEC 60068-2-1
Salt mist	96 hours, +35 °C in a chemical solution with NaCl as per EN IEC 60068-2-11
Level of safety	
EN ISO 13849-1	Up to PL e/Cat. 4 depending upon system architecture
EN 62061	SIL 3 depending upon system architecture
IEC/EN 61508-1...7	SIL 3
PFH_d	4.66E-09
Colour	Yellow, red and black
Weight	Approx. 65 grams
Size	Length: 84 mm + M12 contact(s) (12.5 mm each) Width: 40 mm Height: 52 mm
Material	Polyamid PA66, Macromelt, Polybutylenterephthalate PBT, Polypropylen PP, UL 94 V0
Ambient temperature	-10°C to +55°C (operation) -30°C to +70°C (stock)
Protection class	IP65
Mounting	Two M5 hexagon socket screws, L ≥25 mm. Hole centres: 44 mm
LED on E-Stop	Green: Safety device OK, Safety circuit OK Flashing: Safety device OK, safety circuit previously interrupted Red: This button is pressed, and the safety circuit is interrupted
Time delay	1:1.5 (Two Smile units are equal to three Edens in time delay)
Operating voltage	17-27 VDC ripple ±10%

Current consumption	47 mA (57mA with max. current from information output)
Current from information output	10 mA max
Actuating force	22±4 N
Actuator travel	Approx. 4 mm to latch
Material, contacts	Silver alloy gold plated
Mechanical life	> 50 000 operations
Accessories	
Emergency Stop Sign S DK FIN, 32.5 mm	2TLA030054R0700
Emergency Stop Sign EN F D, 32.5 mm	2TLA030054R0800
Smile side shield	2TLA030054R1100
Conformity	EN ISO 12100:2010 EN ISO 13849-1:2008 EN 62061:2005, EN 60204-1:2006+A1:2009 IEC 60664-1:2007 EN 61000-6-2:2005 EN 61000-6-4:2007 EN 60947-5-5:2005 EN ISO 13850:2006



Smile side shield

Sign for emergency stop

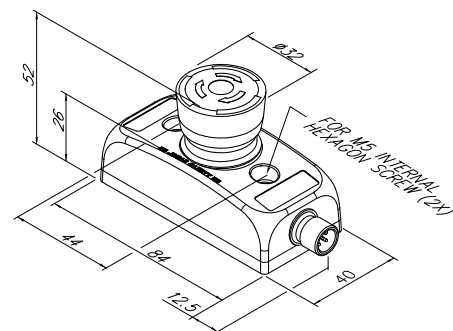

Emergency stop with indication

Smile AS-i



Smile 11 EA AS-i is an emergency stop with a built-in dual channel safe AS-i input node. The AS-i bus and the safety around it is specified by the two organisations “AS-International Association” and “AS-Interface Safety at Work”, and is described in publications such as “AS-Interface The Automatic Solution”.

Smile 11 EA AS-i is supplied with 30 VDC from the AS-i bus. The recommended connection to the AS-i bus is made via a flat cable terminal to M12 (see Figure), which makes it possible to quickly and easily connect the device to the yellow AS-i cable.

11

Smile 11 EA AS-i can also be connected directly to the AS-i bus using only two conductors (pins 1 and 3 on the unit's M12 contact). Smile is also available with black push button and is used in this case as a safety stop. See section on safety stops.

The possibility with LED indication is also available on the Smile 11 EA AS-i, with the difference that the AS-i version has programmable LEDs. This gives the customer full flexibility for making own indication.

Approvals:



Application:

- To stop a machine or a process
- Safe input node in AS-i systems

Features:

- Emergency push button up to PL e/Cat. 4 acc. to EN ISO 13849-1
- Simple connection to AS-i bus
- With LED indication on push button and AS-i status indication
- Robust
- IP65
- Available as safety stop (black push button)

Technical data – Smile AS-i

Article number	Smile 11 EA AS-i	2TLA030052R0000
AS-i data	AS-i profile	S-7.B.0
Addressing	Node address on delivery	M12-contact 0
Response time across the AS-i bus		5 ms (+ response time for safety monitor)
Pin configuration	(1)	AS-i +
	(2)	Not used
	(3)	AS-i –
	(4)	Not used
	(5)	Not used
Operating voltage		30 VDC from the AS-i bus. Tolerance 26.5 – 31.6 VDC.
Total current consumption		< 60 mA
Protection class		IP65
Ambient temperature		-25...+50°C
Dimensions		52 x 40 x 84 (+12,5 mm M12 contact) (H x W x L)
Colour		Yellow, red and black
Actuating force		22 ±4 N
Actuating travel		Approx. 4 mm to latch
Mechanical life		> 50 000 operations
PFH _D		6.95 x 10 ⁻⁹
Level of safety	EN ISO 13849-1	Up to PL e/Cat. 4 depending upon system architecture MTTF _d : high
	EN 62061	SIL 3 depending upon system architecture
	IEC/EN 61508-1...7	SIL 3, PFD _{avr} : 2.95 x 10 ⁻⁵ , PFH _D : 6.95*10 ⁻⁹
Conformity		EN ISO 12100:2010, EN ISO 13849-1:2008/AC:2009, EN ISO 13849-2:2008, EN 60204-1:2007+A1, EN ISO 13850:2006

LED in emergency stop button

LED is individually programmed in the PLC program as shown below.

LED in push button	Indicator	Description
Red	ON	Output bit 1 ON
	OFF	Output bit 1 OFF or Output bit 1 & 2 ON
Green	ON	Output bit 2 ON
	OFF	Output bit 2 OFF or Output bit 1 & 2 ON

AS-i LED and Fault LED

in combination LED pair at the M12 contact.

AS-i (Green)	Fault (Red)	Description
OFF	OFF	AS-i voltage missing
ON	OFF	Normal operation
ON	ON	No data exchange with master
Flash	ON	No data exchange due to address = 0

Emergency stop Compact



Approvals:



Application:

- To stop a machine or a process

Features:

- Assembled compact emergency stop
- Emergency push button up to PL e/Cat. 4 acc. to EN ISO 13849-1
- Robust
- IP67 and IP69K
- Available as safety stop (black push button)

The Compact emergency stop with an enclosure

The emergency stop comes from the Compact range of ABB:s Pilot Devices. The Compact is an "All-in-one design" solution, with button and contact block in one unit. It has a building height of 42 mm.

The emergency stop complemented with a robust enclosure gives a high IP rating that fulfills the demands in severe and moist environments, such as food and beverage industry. This unit is also available with a black push button and a grey enclosure and is then used as a safety stop. See section on safety stops.

Adjustment for dynamic circuits

If the emergency stops are used with Pluto or Vital, a Tina adaptation product can be used. Tina 2A, Tina 2B and Tina 3A all work with the Compact emergency stop and its enclosure.



Compact as a machine stop. See more information on section - Safety stop.

Technical data – Compact

Article number	
Emergency stop and enclosure (CEPY1-1002)	1SFA619821R1002
Emergency stop with enclosure and shroud (CEPY1-2002)	1SFA619821R2002
Reset action	Pull release
Contact material	Silver
Termination Clamp	Up to 1.5 mm ² conductors
Torque settings	
Cable terminals	0.8 Nm
Nut (M22)	Min. 2 Nm, Max. 2.3 Nm
Conduit entries	2 x M20
Rated insulation/withstand voltages	300 V
Thermal current (I _{th})	5 A
Utilisation category	AC-15; 1 A (240 V), 1.5 A (120 V) DC-13; 0.3 A (24 V), 0.2 A (125 V)
Short circuit overload protection	Max. fuse 16 A
Level of safety	
B10 _d	50 000
Colour	Yellow, red, black and grey
Weight	135 g (with Shroud) 118 g
Size	Length: 65 mm Width: 65 mm Height: 78.1 mm (with Shroud 79.6 mm)
Ambient temperature	-25°C to +70°C (operation) -30°C to +85°C (stock)
Protection class	IP66, IP67 and IP69K
Mounting	2 x M4
Mechanical life	50 000 operations
Accessories	
Shroud Yellow (CA1-8053)	1SFA619920R8053
Shroud Grey (CA1-8054)	1SFA619920R8054
Tina 2A	2TLA020054R0100
Tina 2B	2TLA020054R1100
Tina 3A	2TLA020054R0200
Conformity	EN 60947-1:2007, EN 60947-5-1:2004, EN 60947-5-5:1997+A1:2005



Adaptation units: Tina 2A and Tina 3A

Emergency stop EStrongZ



Approvals:



Application:

- To stop a machine or a process

Features:

- Compact and robust
- Universal installation
- Stainless steel
- LED status indication (optional)
- 2NO + 2NC
- EX version

Switch operational description

The EStrongZ is an emergency stop designed to provide a robust unit in exposed and severe environments. Perfect for industries that have special demands.

The contact block configuration is a 2NC and 2NO and the emergency stop is mounted with 4 x M4 screws from the inside.

The EStrongZ has a special lid that is mechanical linked to the emergency stop safety mechanism. This means that the safety contacts will open if the lid is removed. An optional feature gives the EStrongZ a two colour LED that can be seen easily from a distance.

Material

The EStrongZ is available in a total rugged stainless steel 316 body, developed for applications such as food processing and chemical industry. With a double seal lid gasket and seals, the EStrongZ has an IP69K enclosure protection and therefore can be high pressure hosed with detergent at high temperature.

Explosion Proof version (X)

EStrongZ also exist in versions with certified explosion proof contact block (X-versions). EStrongZX have a stainless steel body and can be used in European Zone 1, 2, 21, 22 environments (Gas and Dust). Preassembled with 3 meter cable.

Regulations and Standards

The EStrongZ is designed and approved in accordance to relevant standards. Examples of relevant standards are IEC/EN 60947-5-1, IEC/EN 60947-5-5, EN 62061, UL 508, EN ISO 13850 and EN ISO 13849-1.

Technical data – EStrongZ series

Article number	
EStrongZ	2TLA050220R0020
EStrongZ (LED)	2TLA050220R0222
EStrongZX	2TLA050220R0025
Level of Safety	
EN ISO 13849-1	Up to PL e/Cat. 4 depending upon system architecture
EN 62061	Up to SIL3 depending upon system architecture
Safety data	
Mechanical reliability B_{10d}	1.5×10^6 operations at 100mA load 21 years
Proof test interval (life) $MTTF_d$	214 years (8 cycles per hour/24 hours per day/365 days)
Torque settings	
	Mounting M5 4.0Nm, Lid T20 Torx M4 1.5Nm, Terminals 1.0Nm
Termination	
	Clamp up to 2.5 mm ² conductors
Short circuit overload protection	
	Fuse externally 10A (FF)
Rated insulation/withstand voltages	
	500VAC / 2500VAC
Utilisation category	
	AC15 A300 3A
Shock resistance	
	15 g 11 ms
Thermal current (Ith)	
	10A
Conduit entries	
	3 x M20
Enclosure classification	
	IP67 and IP69K
Operating temperature	
	-25°C to +80°C
Weight	
	820 g
Contact type	
	IEC/EN 60947-5-1 double break typ Zb snap action
Contact material	
	Silver
Enclosure / Cover	
	Stainless steel 316
Mounting position	
	Any
Mounting bolts	
	4 x M4
Explosion Proof version (X)	
Classification Ex d IIC T6	(-20°C ≤ Ta ≤ +60°C) Gb Ex tb IIIC T85°C (-20°C ≤ Ta ≤ +60°C) Db
Rated Voltage	250V AC/DC
Rated Current	2 pole 4A 4 pole 2.5A



EStrongZ (LED)



EStrongZ

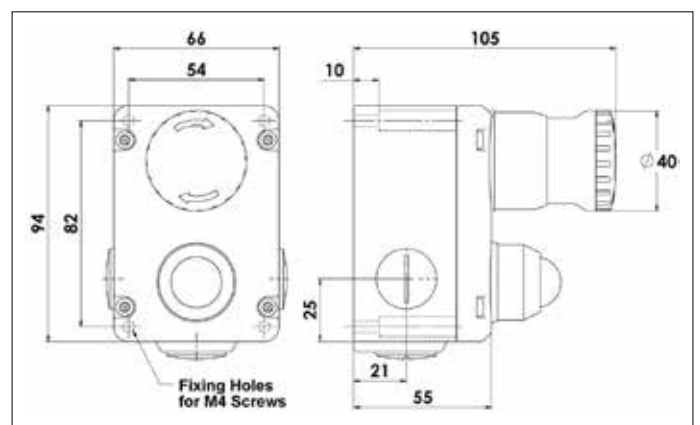

Dimensions EStrongZ (LED)

Safety stop INCA, Smile and Compact



Approvals:



Application:

- To make a safe stop of a machine or a process

Features:

- Safe machine stop with black push button
- With LED info in push button
- Up to IP69K
- Info output (Tina)

When should I use the safety stop?

Safety stops are used to stop the operation of a machine in a safe manner. It must not be used as an emergency stop, but only as a stop for an individual hazardous motion. This is indicated by black push button. Likewise, an emergency stop push button with red push button must not be used as a safety stop.

INCA machine stop for panel mounting

The INCA series is available with black push button and is called INCA 1S/INCA 1S Tina. The safety stop is identical to the corresponding emergency stop apart from the black push button. For technical data see the INCA emergency stop.

Smile machine stop with indication

The Smile emergency stop series is also available with black push button as safety stops. These stops are identical to the corresponding emergency stops apart from the button. The Smile with the black push button has a similar designation apart from an S in the name instead of E. For technical data see the Smile emergency stop.

The Compact Machine stop with an enclosure

This machine stop comes from the Compact range of ABB:s Pilot Devices, built on the "All-in-one design". The black machine stop complemented with a robust enclosure gives a high IP rating the fulfills the demands in severe and moist environments. The machine stop has one normal open and one normally closed contact (1NO+1NC). For technical data see the Compact emergency stop.

Model	Article number
Smile 11 SA	2TLA030051R0900
Smile 12 SA	2TLA030051R1000
Smile 11 SAR	2TLA030051R1100
Smile 11 SA Tina	2TLA030050R0500
Smile 12 SA Tina	2TLA030050R0600
Smile 11 SAR Tina	2TLA030050R0700
Smile 12 SAR Tina	2TLA030050R0800
Smile 11 SA AS-i	2TLA030052R0100

Model	Article number
INCA 1S	2TLA030054R0300
INCA 1S Tina	2TLA030054R0200

Model	Article number
Machine stop and enclosure (CEP1-1002)	1SFA619811R1002
Machine stop with enclosure and shroud (CEP1-2002)	1SFA619811R2002

Reset button Smile 11 R

Approvals:



Application:

- Reset push button

Features:

- With LED info in push button
- IP65
- Adapted version for the Pluto feature "light button"



Smile push button box with a blue button are intended to be a reset button to safety circuits.

Smile 11 RA

The Smile 11 RA is an "open" reset push button box with one circuit for connections through a normally open contact and one circuit for connection of the indication LED in the push button.

Smile 11 RB

The Smile 11 RB is a reset push button box adapted to be used together with the Safety PLC Pluto.

The Safety PLC Pluto has a function called "Light button" which is used in order to reduce the numbers of terminals on the Pluto. With this function, one terminal can be used both as an input for the reset as well as output for controlling the LED. This function demands special connection for the reset button and its light indication, which the Smile 11 RB offers.

Technical data – Smile 11 RA/B

Article number	
Smile 11 RA	2TLA030053R0000
Smile 11 RB	2TLA030053R0100
Color	
Base	yellow
Pushbutton	blue
Material	
Housing	Polypropylene PP
Pushbutton contact	Au
Power Supply	
LED operating voltage	24 VDC (maximum 33 VDC)
LED current consumption	20 mA at 24 VDC 30 mA at 33 VDC
Pushbutton operating voltage	Min: 5 V, max: 35 V
Pushbutton current consumption	Min: 1 mA, max 100 mA
Pushbutton rated power	Max: 250 mW
Ambient temperature	-25...+55°C
Humidity range	35 to 85% (with no icing or condensation)
Protection class	IP65
Connectors	5-pole male M12 connector
Size	84 x 40 x 36 (LxWxH) + 12 mm for M12 connector (L)
Weight	Approx. 60 g
Mechanical life	1.000.000 operations at 10 mA/24 VDC
Switching reliability	10 x 10 ⁻⁶ at 5 mA/24 VDC

Emergency Stop Grab Wire Safety Switches

Application

ABB Jokab Safety Emergency stop grab wire safety switches are designed to be mounted on machines and sections of conveyors which can not be protected by guards. In contrast to traditional mushroom head type Emergency stop buttons, Emergency stop grab wire safety switches can initiate the emergency command from any point along the installed wire length, and thereby provide robust emergency stop protection for exposed conveyors and machines.

The switches have a positive mechanical linkage between the switch contacts and the wire rope. The switches also include wire-breakage monitoring. This means, on pulling or breakage (tension loss) of the wire, the safety contacts are positively opened and the auxiliary contacts are closed. The switches are mechanically latched and can then only be returned to the operational condition by pressing the reset button as required according to EN ISO 13850 (EN 418).

System set up

Wire support eyebolts must be fitted at 2.5-3 meters intervals along the hole wire length and the wire must be supported no more than 500 mm from the switch eyebolt or Safety Spring (if used). It is important that the first 500 mm not are used as part of the active protection coverage. When using one switch, the wire must be anchored at the other end using a Safety spring. When using a Safety spring, a maximum of one corner pulley may be used, to ensure that the complete length of the wire is visible to either the switch or the spring anchorage. The emergency stop switches are brought into the operational condition by pre-tensioning the wire by using a tensioner / gripper device which clamps the wire and then hooks to the switch eyebolts. Correct tension can be observed by viewing the tension indicator on the switch housing. Once tensioned, the switch contact blocks can be set to the operational condition (safety contacts closed, auxiliary contacts open) by pressing a blue reset button on the switch cover.

Safety level

All ABB Jokab Safety Emergency stop grab wire safety switches conform to European Standard EN ISO 13850 (EN 418) and IEC/EN 60947-5-5. They have a positive mechanical linkage between the switch contacts and the wire rope as per IEC/EN 60947-5-1.

In combination with a dual channel safety monitoring relay (or safety PLC) an Emergency stop grab wire system can be used as emergency stop device monitored for up to PL e, Cat 4 according to EN ISO 13849-1.

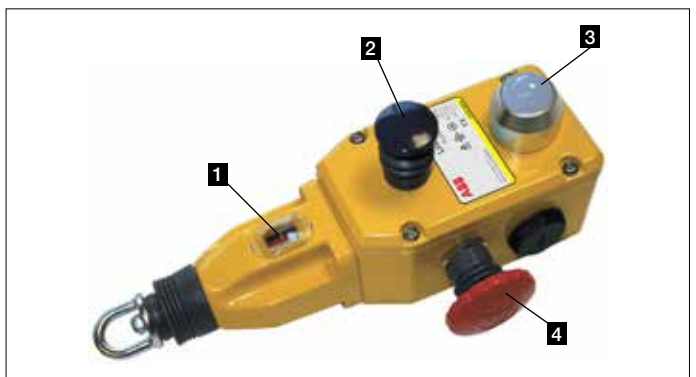

1. Tension indicator -Ensures the system is easy to set up and maintain the correct wire tension.
2. Reset button -The blue button must be pushed to reset the switch following activation by pulling or slackening of the wire.
3. Indicator LED -Can be wired to flash red in the event of the wire being pulled-switch activated, or illuminate steady green to indicate a reset switch in machine 'Run' state. Visible from long distances.
4. Mushroom type Emergency stop button -Can be installed or repositioned left or right after installation.

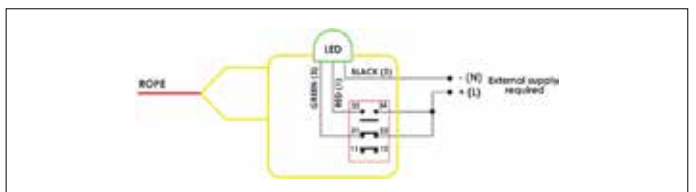

Wiring diagram for LED

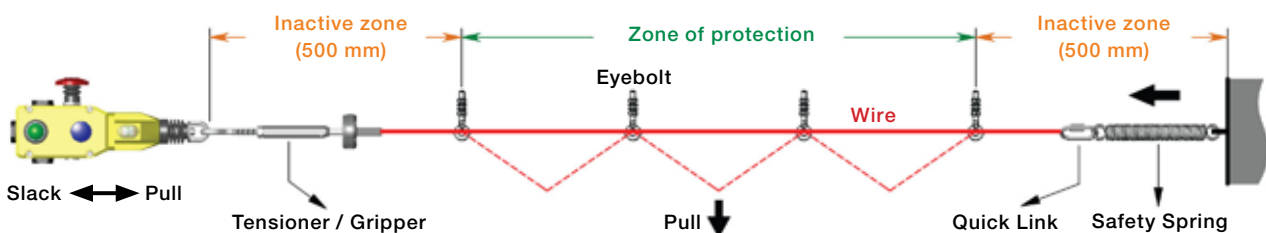

Reliable connectivity

When setting up an Emergency stop grab wire system from ABB Jokab Safety it is recommended to do the tensioning of the wire by using of ABB Jokab Safety Tensioner / Gripper accessory. Traditional grab wire systems normally need turn-buckle and clamps, which are difficult to tension and adjust, and also normally require frequent re-tensioning.

For greater reliability and ease, of installation the Tensioner / Gripper accessory significantly reduces the installation time. This by offering an eyehook, tensioner thimble and wire strength gripper in one assembly which enables rapid connection to the switch eyebolts and fast and accurate tensioning of the wire. Thanks to the switch viewing window, systems can be accurately and quickly tensioned. The double clamp mechanism prevents wire slippage and significantly reduces machine 'down time' which can occur which traditional turn-buckle systems.



Wire Tensioner / Gripper, Stainless Steel article no: 2TLA050210R4020,
Wire Tensioner / Gripper, Galvanized article no: 2TLA050210R4030.

Tensioner / Gripper installation

The end of the safety wire is fed through a central hole in a cone shaped guide which protrudes from the main housing. After being fed through the guide hole, the wire enters the main housing by going through a feed hole and then is looped back through 180 degrees and is fed through a second feed hole on the opposite side of the mechanism. The wire is then pulled for maximum tension and is locked in position by a locking bar inside the main housing which is moved by turning an Allen type locking bolt.

Navigating Corners

Because of the added friction on the eyebolts and wire when navigating corners, a corner pulley can be used to navigate inside or outside corners without causing damage to the wire. They are stainless steel and can be rigidly mounted.

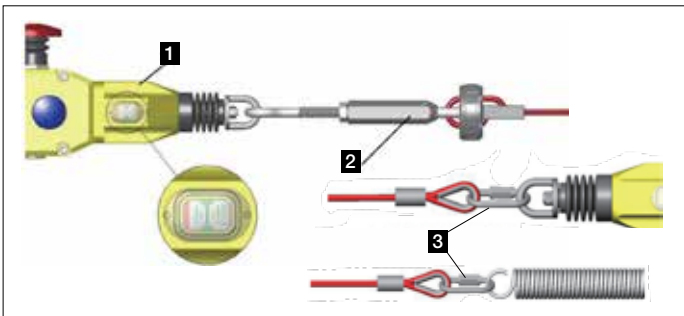

1. Tension to mid position as indicated by the green arrows in the viewing window of each switch.
2. The tensioner thimble allows immediate accurate and final tensioning of the wire, whilst viewing the tension marker through the viewing window on the switch.
3. For systems up to 50 meter Quick Link termination is provided for easy connection to either a Safety spring or Switch eyebolt. (Note for systems above 50 meter a Tensioner / Gripper is required each side).

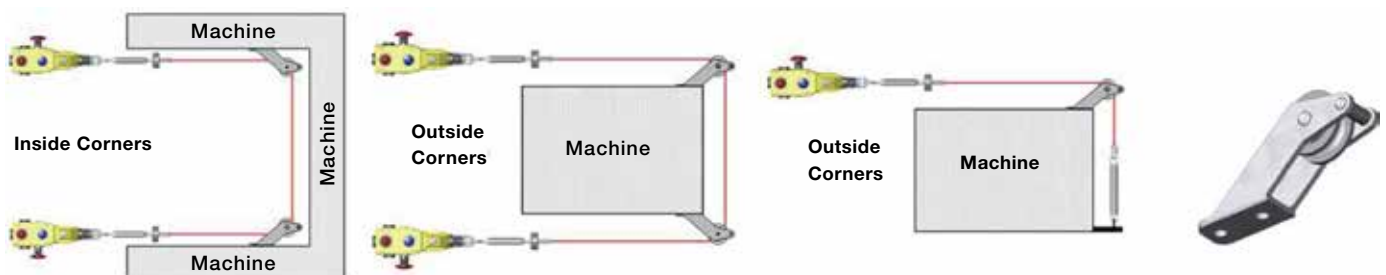

Examples of using the corner pulley

Emergency Stop Grab Wire Safety Switch LineStrong1

Approvals:



Application:

- Machines
- Transportation lines

Features:

- Easily accessible
- Forced contacts
- Double switching in both directions of travel
- Up to 50 m Wire length
- IP67
- 2NO + 2NC



Switch operational description

LineStrong1 is an emergency stop grab wire safety switch used for easy reach of an emergency stop along machines, conveyors and processes. LineStrong1 is a compact and small, yet robust switch that can handle wires up to 30 meters on a single switch (up to 50 meters on two switches).

A grab wire emergency stop is easier to install than a system of several emergency stop buttons along a carriage path. LineStrong1 can be used as protection, for example along a conveyors with low risks where the wire can be installed at waist height in front of the conveyor, which provides an emergency stop if someone walks or falls towards the conveyor. LineStrong1 has double switching in both directions of the wire. So if someone pulls the wire or if the wire is broken, the switch goes to a safe state, e.g. the machine is emergency-stopped. After a safe state the LineStrong1 needs to be reset to be able to run again and this is made on the local reset button. LineStrong1 is equipped with an indication of how taut the wire is, which make the installation or adjustment easy.

Material

The LineStrong1 is made a rugged die cast housing with a rating of IP67.

Positive forced disconnected contacts

A positive forced contact provides a forced disconnect of the safety contacts when the wire is being pulled or broken. The design of the LineStrong1 ensures that the contacts will

not fail or be held in a normally closed position, due to failure of the spring mechanism or that welding/sticking of the contacts can occur. The LineStrong1 switch has 2NC and 2NO contacts.

Safety level

The forced disconnected contacts provide a high level of safety. To achieve a maximum safety level in connection with the machine control system, it is recommended that the LineStrong1 is monitored by an appropriate ABB Jokab Safety safety relay, Pluto safety-PLC or a Vital system.

Regulations and Standards

The LineStrong1 is designed and approved in accordance to relevant standards. Examples of relevant standards are IEC/EN 60947-5-1, IEC/EN 60947-5-5, EN 62061, UL 508, EN ISO 13850 and EN ISO 13849-1.

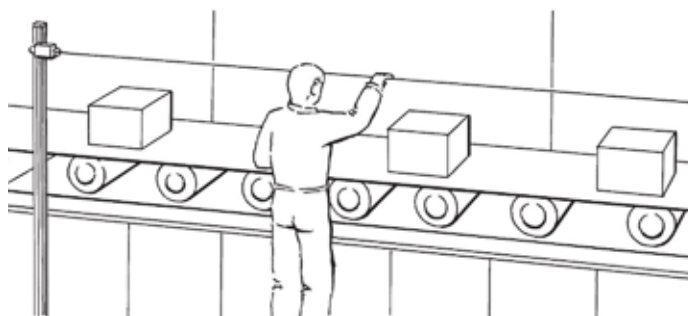

Emergency stop grab wire easily accessible during normal work operation along a machine.

Technical data – LineStrong1 series

Article number	2TLA050200R0030
LineStrong1	
Level of Safety	
EN ISO 13849-1	Up to PL e /Cat. 4 depending upon system architecture
EN 62061	Up to SIL3 depending upon system architecture
Safety data	
Mechanical reliability B_{10d}	1.5×10^6 operations at 100mA load 21 years
Proof test interval (life) $MTTF_d$	214 years (8 cycles per hour/24 hours per day/365 days)
Wire span	up to 50 m
Wire tension device	Tensioner / Gripper- Quick Fixing
Wire type	PVC sheath steel wire 4.0 mm outside diameter
Torque settings	Mounting M5 4.0Nm, Lid T20 Torx M4 1.5Nm, Terminals 1.0Nm
Termination	Clamp up to 2.5 mm ² conductors
Tension force (typical mid setting)	130N
Tension operating force (wire pulled)	< 125N < 300 mm deflection
Short circuit overload protection	Fuse externally 10 A (FF)
Rated insulation/withstand voltages	500 VAC / 2500 VAC
Utilisation category	AC15 A300 3A
Vibration resistance	10-500 Hz 0.35 mm
Shock resistance	15 g 11 ms
Thermal current (Ith)	10A
Contact type	IEC/EN 60947-5-1 double break Typ Zb snap action
Contact material	Silver
Conduit entries	3 x M20 x 1.5
Enclosure classification	IP67
Ambient temperature	-25°C to +80°C
Enclosure material/cover	Die cast painted yellow
Mounting position	Any
Mounting bolts	4 x M5

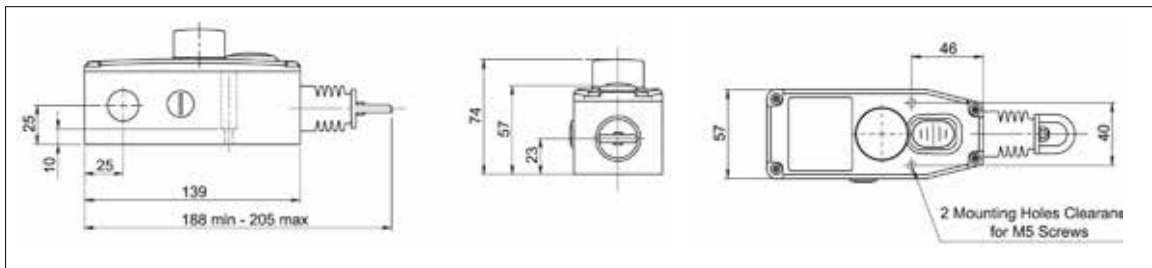

Dimension LineStrong1

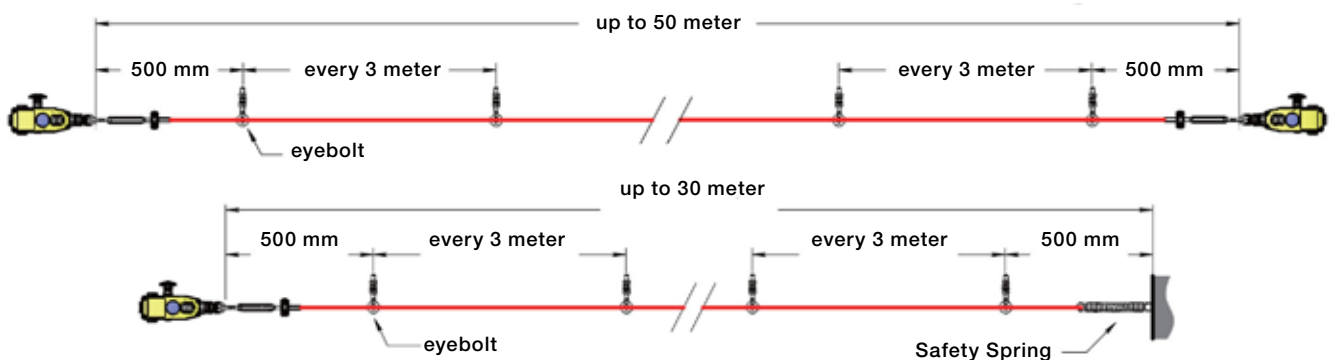

Emergency Stop Grab Wire Safety Switch LineStrong2



Approvals:



Application:

- Machines
- Transportation lines

Features:

- Duplicate extraction in two directions
- Up to 100 m length
- Up to IP69K
- Integrated emergency stop button
- 2NO + 2NC
- EX version

Switch operational description

LineStrong2 is an emergency stop grab wire safety switch used for easy reach of an emergency stop along machines, conveyors and processes. LineStrong2 is a robust switch that can handle wires up to 80 meters on a single switch (up to 100 meters on two switches). A grab wire emergency stop is easier to install than a system of several emergency stop buttons along a carriage path. LineStrong2 can be used as protection, for example along conveyors with low risks, where the wire can be installed at waist height in front of the conveyor, which provides an emergency stop if someone walks or falls towards the conveyor. LineStrong2 has double switching in both directions of the wire. If someone pulls the wire or if the wire is broken, the switch goes to a safe state, e.g. the machine is emergency-stopped. After a safe state the LineStrong2 needs to be reset to be able to run again and this is made with the local reset button. Additional features on the LineStrong2 are a "normal" emergency stop that is fitted on the side of the grab wire safety switch and also a two coloured LED for indication. LineStrong2 is equipped with an indication of how taut the wire is, which make the installation and adjustment easy.

Material

Depending on the environment where the switch will be used, different material can be chosen for the LineStrong2. The basic version has a rugged yellow die cast housing with a rating of IP67. In severe applications as for food processing and chemical industry there is a LineStrong2Z with a total rugged stainless steel 316 body. This version has IP69K enclosure protection (maintained by a double seal lid gasket and seals)

and can be high pressure hosed with detergent at high temperature.

Positive forced disconnected contacts

A positive forced contact provides a forced disconnect of the safety contacts when the wire is being pulled or broken. The design of the LineStrong2 ensures that the contacts will not fail or be held in a normally closed position, due to failure of the spring mechanism or that welding/sticking of the contacts can occur. The LineStrong2 switch has 2NC and 2NO contacts.

Safety level

The forced disconnected contacts provide a high level of safety. To achieve a maximum safety level in the connection with the machine control system, it is recommended that the LineStrong2 is monitored by an appropriate ABB Jokab Safety safety relay, Pluto safety-PLC or a Vital system.

Explosion Proof version (X)

LineStrong2 also exist in versions with certified explosion proof contact block (X-versions). LineStrong2ZX have a stainless steel body and can be used in European Zone 1, 2, 21, 22 environments (Gas and Dust). Preassembled with 3 meter cable.

Regulations and Standards

The LineStrong2 is designed and approved in accordance to relevant standards. Examples of relevant standards are IEC/EN 60947-5-1, IEC/EN 60947-5-5, EN 62061, UL 508, EN ISO 13850 and EN ISO 13849-1.

Technical data – LineStrong2 series

Article number	
LineStrong2	2TLA050202R0332
LineStrong2Z	2TLA050202R0322
LineStrong2ZX (EX)	2TLA050202R7125
Level of Safety	
EN ISO 13849-1	Up to PL e/Cat. 4 depending upon system architecture
EN 62061	Up to SIL3 depending upon system architecture
Safety data	
Mechanical Reliability B_{10d}	1.5×10^6 operations at 100mA load
Proof test interval (life)	21 years
MTTF _d	214 years (8 cycles per hour/24 hours per day/365 days)
Wire span	
LineStrong2	Up to 80 m
LineStrong2Z(X)	Up to 100 m
Wire tension device	
	Tensioner / Gripper- Quick Fixing
Wire type	
	PVC sheath steel wire 4.0 mm outside diameter
Torque settings	
	Mounting M5 4.0Nm lid T20 Torx M4 1.5Nm terminals 1.0Nm
Termination	
	Clamp up to 2.5 mm ² conductors
Tension force (typical mid setting)	
	130N
Tension operating force (wire pulled)	
	< 125N < 300 mm deflection
Short circuit overload protection	
	Fuse externally 10A (FF)
Rated insulation/withstand voltages	
	500VAC / 2500VAC
Utilisation category	
	AC15 A300 3A
Vibration resistance	
	10-500Hz 0.35 mm
Shock resistance	
	15 g 11 ms
Thermal current (I_{th})	
	10A
LED	
	24 VDC

Contact type	IEC/EN 60947-5-1 double break Typ Zb snap action
Contact material	Silver
Conduit entries	3 x M20 x 1.5
Enclosure classification	
LineStrong2	IP67
LineStrong2Z(X)	IP69K and IP67
Ambient temperature:	
LineStrong2	-25°C to +80°C
LineStrong2Z(X)	-25°C to +80°C (100°C cleaning)
Enclosure material/cover	
LineStrong2	Die cast painted yellow
LineStrong2Z(X)	Stainless steel 316
Mounting position	
	Any
Mounting bolts	
	4 x M5
Explosion Proof version (X)	
Classification	Ex d IIC T6 (-20°C ≤ Ta ≤ +60°C) Gb Ex tb IIIC T85°C (-20°C ≤ Ta ≤ +60°C) Db
Rated Voltage	250V AC/DC
Rated Current	2 pole 4A 4 pole 2.5A

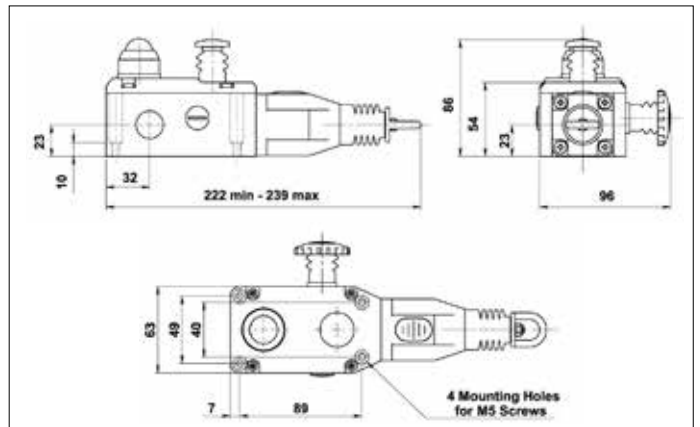

Dimensions LineStrong2 and LineStrong2Z

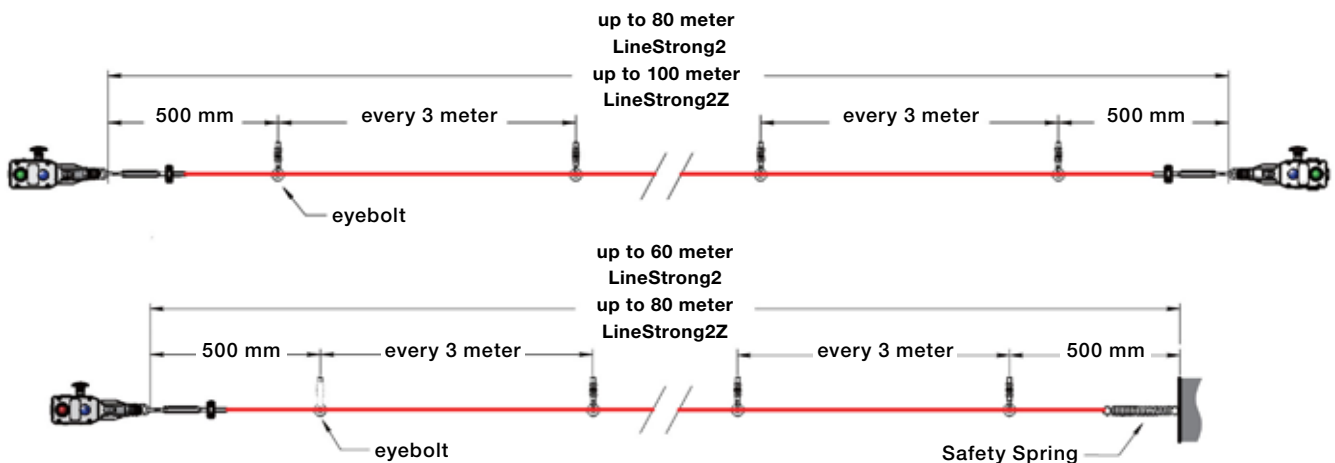

Emergency Stop Grab Wire Safety Switch LineStrong3



Approvals:



Application:

- Machines
- Transportation lines

Features:

- Duplicate extraction in two directions
- Up to 250 m length
- Up to IP69K
- Integrated emergency stop button
- 4NC + 2NO
- EX version

Switch operational description

LineStrong3 is an emergency stop grab wire safety switch used for easy reach of an emergency stop along machines, conveyors and processes. LineStrong3 is a quite robust switch that can handle long wires, up to 250 meters on a single switch. A grab wire emergency stop is easier to install than a system of several emergency stop buttons along a carriage path. LineStrong3 can be used as protection, for example along conveyors, with low risks where the wire can be installed at waist height in front of the conveyor, which provides an emergency stop if someone walks or falls towards the conveyor.

LineStrong3 has double switching in both directions of the wire. If someone pulls the wire or if the wire is broken, the switch goes to a safe state, e.g. the machine is stopped.

After a safe state the LineStrong3 needs to be reset to be able to run again and this is made on the local reset button. Additional features on the LineStrong3 is a "normal" emergency stop fitted on the top of the grab wire safety switch and also a two coloured LED for indication.

LineStrong3 is equipped with an indication of how taut the wire is, which make the installation and adjustment easy.

Material

Depending on the environment where the switch will be used, different materials can be chosen for the LineStrong3. The basic version has a rugged yellow die cast housing with a rating of IP67. In severe applications as for food processing and chemical industry, there is a LineStrong3Z with a total

rugged stainless steel 316 body. This version has IP69K enclosure protection (maintained by a double seal lid gasket and seals) and can be high pressure hosed with detergent at high temperature.

Positive forced disconnected contacts

A positive forced contact provides a forced disconnect of the safety contacts when the wire is being pulled or broken. The design of the LineStrong3 ensures that the contacts will not fail or be held in a normally closed position, due to failure of the spring mechanism or that welding/sticking of the contacts can occur. The LineStrong3 switch has 4NC and 2NO.

Safety level

The forced disconnected contacts provide a high level of safety. To achieve a maximum safety level in the connection with the machine control system, it is recommended that the LineStrong3 is monitored by an appropriate ABB Jokab Safety safety relay, Pluto safety-PLC or a Vital system.

Explosion Proof version (X)

LineStrong3 also exist in versions with certified explosion proof contact block (X-versions). LineStrong3LZX/RZX/DZX have a stainless steel body and can be used in European Zone 1, 2, 21, 22 environments (Gas and Dust). Preassembled with 3 meter cable.

Regulations and Standards

The LineStrong3 is designed and approved in accordance to relevant standards. Examples of relevant standards are IEC/EN 60947-5-1, IEC/EN 60947-5-5, EN 62061, UL 508, EN ISO 13850 and EN ISO 13849-1.

Single Wire

LineStrong3L/3R and LineStrong3LZ/3RZ

LineStrong3L/3R - Standard version

The LineStrong3L/3R are two different versions depending on installation.

L - "Left hand" - is the version of LineStrong3 where the placement of the grab wire switch is to the left in the installation.

R - "Right hand" - is the version of LineStrong3 where the placement of the grab wire switch is to the right in the installation.

Both versions have die-cast housings and are robust to severe indoor or outdoor use. LineStrong3L/3R are designed to protect a length up to 100 meters on a single switch. If two switches are used together, up to 125 meters. A two colour LED ensures switch status can be seen easily from a distance. They have 4NC and 2NO contacts to ensure flexibility with all modern control application.

LineStrong3LZ/3RZ - Stainless steel version

The LineStrong3LZ/3RZ are two stainless steel switches with different installations possibilities.

L - "Left hand" - is the version of LineStrong3Z where the placement of the grab wire switch is to the left in the installation.

R - "Right hand" - is the version of LineStrong3Z where the placement of the grab wire switch is to the right in the installation.

Both versions are in stainless steel 316 housings and are designed specifically to withstand the tough environments found in the food and pharmaceutical industries. LineStrong3LZ/3RZ are designed to protect a length up to 100 meters on a single switch. If two switches are used together, up to 125 meters. A two colour LED ensures switch status can be seen easily from a distance. They have 4NC and 2NO contacts to ensure flexibility with all modern control application.

Left hand

Right hand

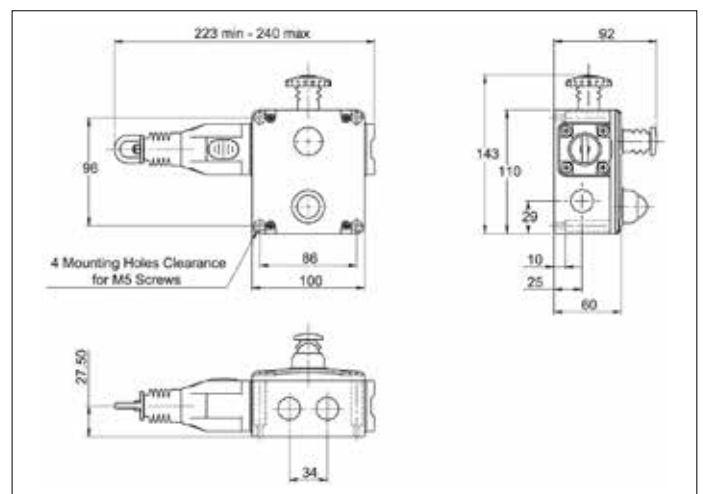

Dimensions LineStrong3L/R and LineStrong3LZ/RZ

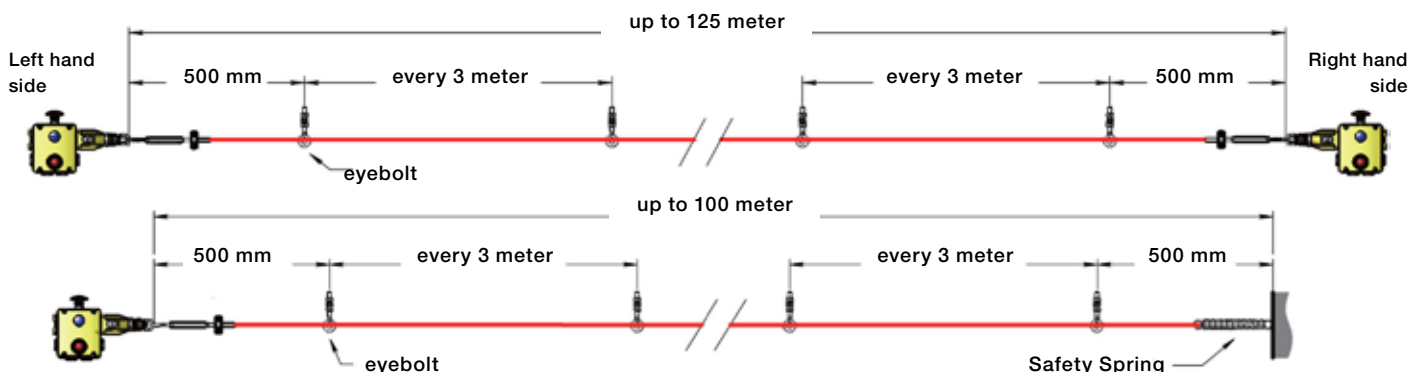

Double Wire LineStrong3D and LineStrong3DZ

LineStrong3D - Standard version

The LineStrong3D is a third version of the Linstrong3. With wire entries from both sides of the grab wire switch, LineStrong3D can be used for a long protection length. The LineStrong3D has a die-cast housing and is robust to manage severe indoor or outdoor use. LineStrong3D is designed to protect a length up to 200 meters on a single switch. If several switches are used together, it will be possible with a length up to 125 meters between the switches. A two colour LED ensures switch status can be seen easily from a distance. LineStrong3D have 4NC and 2NO contacts to ensure flexibility with all modern control application.



LineStrong3DZ - Stainless steel version

The LineStrong3DZ is a third version of the Linstrong3Z. As a stainless steel version with wire entries on both sides of the grab wire switch, LineStrong3DZ can be used for a long protection length.

The LineStrong3DZ has stainless steel 316 housing and is designed specifically to withstand the tough environments found in the food and pharmaceutical industries. LineStrong3DZ is designed to protect a length up to 200 meters on a single switch. If several switches are used together it will be possible with a length up to 125 meters between the switches. A two colour LED ensures switch status can be seen easily from a distance. LineStrong3DZ have 4NC and 2NO contacts to ensure flexibility with all modern control application.

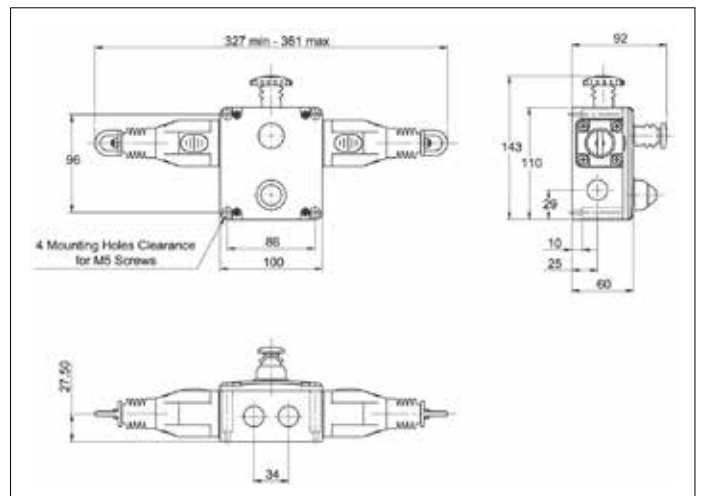

Dimensions LineStrong3D and LineStrong3DZ

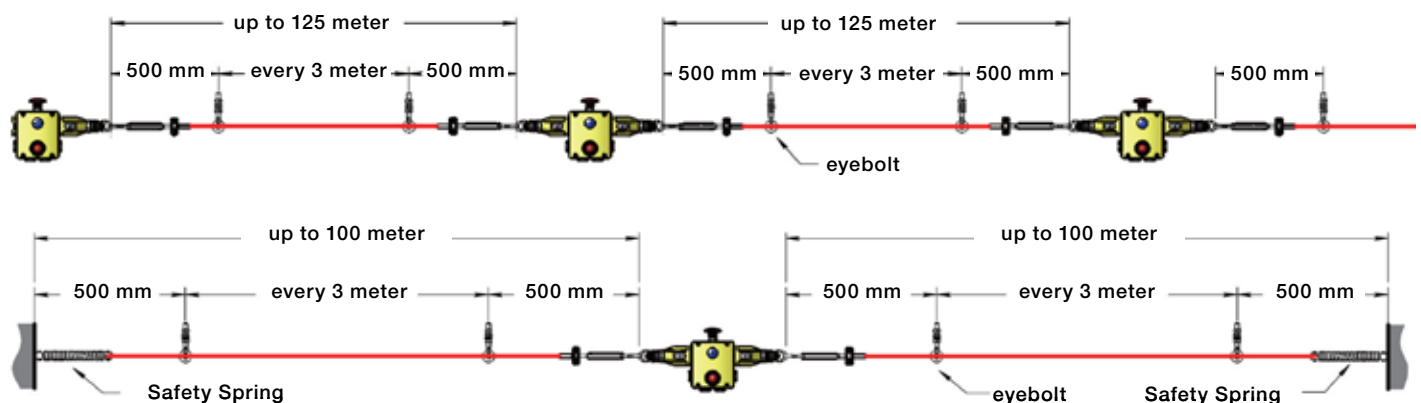

Technical data – LineStrong3 series

Article number	
LineStrong3L	2TLA050206R0332
LineStrong3R	2TLA050208R0332
LineStrong3LZ	2TLA050206R0322
LineStrong3RZ	2TLA050208R0322
LineStrong3LZX (EX)	2TLA050204R7125
LineStrong3RZX (EX)	2TLA050206R7125
LineStrong3D	2TLA050204R0332
LineStrong3DZ	2TLA050204R0322
LineStrong3DZX (EX)	2TLA050208R7125
Level of Safety	
EN ISO 13849-1	Up to PL e, Cat. 4 depending upon system architecture
EN 62061	Up to SIL3 depending upon system architecture
Safety data	
Mechanical reliability B_{10d}	1.5×10^6 operations at 100mA load 21 years
Proof test interval (life) $MTTF_d$	214 years (8 cycles per hour/24 hours per day/365 days)
Wire span	
LineStrong3L/R/LZ(X)/RZ(X)	Up to 125 m
LineStrong3D/DZ(X)	Up to 250 m
Wire tension device	
	Tensioner / Gripper- Quick Fixing
Wire type	
	PVC sheath steel wire 4.0 mm outside diameter
Torque settings	
	Mounting M5 4.0Nm, Lid T20 Torx M4 1.5Nm, Terminals 1.0Nm
Termination	
	Clamp up to 2.5 mm ² conductors
Tension force (typical mid setting)	
	130N
Tension operating force (wire pulled)	
	< 125N < 300 mm deflection
Short circuit overload Protection	
	Fuse externally 10A (FF)
Rated insulation/withstand voltages	
	500VAC / 2500VAC
Utilisation category	
	AC15 A300 3A
Vibration resistance	
	10-500Hz 0.35 mm
Shock resistance	
	15 g 11 ms
Thermal current (I_{th})	
	10A
LED	
	24 VDC
Contact type	
	IEC/EN 60947-5-1 double break Typ Zb snap action
Contact material	
	Silver
Conduit entries	
	4 x M20 x 1.5
Enclosure classification	
LineStrong3D/L/R	IP67
LineStrong3LZ(X)/RZ(X)/DZ(X)	IP69K and IP67
Ambient temperature:	
LineStrong3L/R/D	-25°C to +80°C
LineStrong3LZ(X)/RZ(X)/DZ(X)	-25°C to +80°C (100°C cleaning)
Enclosure material/cover:	
LineStrong3L/R/D	Die cast painted yellow
LineStrong3LZ(X)/RZ(X)/DZ(X)	stainless steel 316
Mounting position	
	Any
Mounting bolts	
	4 x M5
Explosion Proof version (X)	
Classification	Ex d IIC T6 (-20°C ≤ Ta ≤ +60°C) Gb Ex tb IIIC T85°C (-20°C ≤ Ta ≤ +60°C) Db
Rated Voltage	250V AC/DC
Rated Current	2 pole 4A 4 pole 2.5A

Emergency Stop Grab Wire Safety Switch Accessories



Accessories

Type		Article number
Wire pull kit includes: Wire, Eyebolts, Tensioner /Gripper, Allen key		
Galvanized wire pull kits	10 m wire kit	2TLA050210R0130
	20 m wire kit	2TLA050210R0330
	80 m wire kit	2TLA050210R0630
	100 m wire kit	2TLA050210R0730
Stainless steel wire pull kits	50 m wire kit	2TLA050210R0520
	100 m wire kit	2TLA050210R0720
Wire only	10 m wire	2TLA050210R2120
	80 m wire	2TLA050210R2520
	100 m wire	2TLA050210R2620
	1 m wire (order by length)	2TLA020034R0500
Wire Tensioner / Gripper	Tensioner / Gripper, galvanized	2TLA050210R4030
	Tensioner / Gripper, stainless steel	2TLA050210R4020
Corner pulley	Corner pulley, galvanized	2TLA050210R6030
	Corner pulley, stainless steel	2TLA050210R6020
Eyebolt	Eyebolt, M8 x 1.25, galvanized	2TLA050210R8030
	Eyebolt, M8 x 1.25, stainless steel	2TLA050210R8020
General wire pull accessories	Safety spring, 220 mm long, stainless steel	2TLA050211R0004
	Screw driver, Anti-Tamper, Torx T20	2TLA050211R0006
Gland and plug	M20 x 1.5 gland	2TLA050040R0002
	M20 x 1.5 conduit plug	2TLA050040R0004



Contact edges, Bumpers and Safety mats

When shall I use Contact edges, Bumpers and Safety mats?	12/3
Safety contact edges	12/4
Safety bumpers	12/7
Safety mats	12/9
Electrical connections	12/12

When shall I use Safety contact edges, Safety bumpers and Safety mats?

Contact edges and Bumpers

Contact edges are used as protection against squeezing accidents, i.e. on moving machine parts and automatic doors and hatches. The strips come in customised lengths and various cross sections.

Bumpers are used as safety buffers to protect against remote control transport vehicles and other dangerous moving objects that require long stopping distances.

Safety mats

Safety mats are used for protection around hazardous machinery. They are well suited for monitoring an area used for loading and unloading of material to a machine.



Standard: EN 1760-2 Safety of machinery - Pressure sensitive protective devices - Part 2: General principles for the design and testing of pressure sensitive edges and pressure sensitive bars



Standard: EN 1760-1 Safety of machinery - Pressure sensitive protective devices - Part 1: General principles for the design and testing of pressure sensitive mats and pressure sensitive floors

Fields of Application

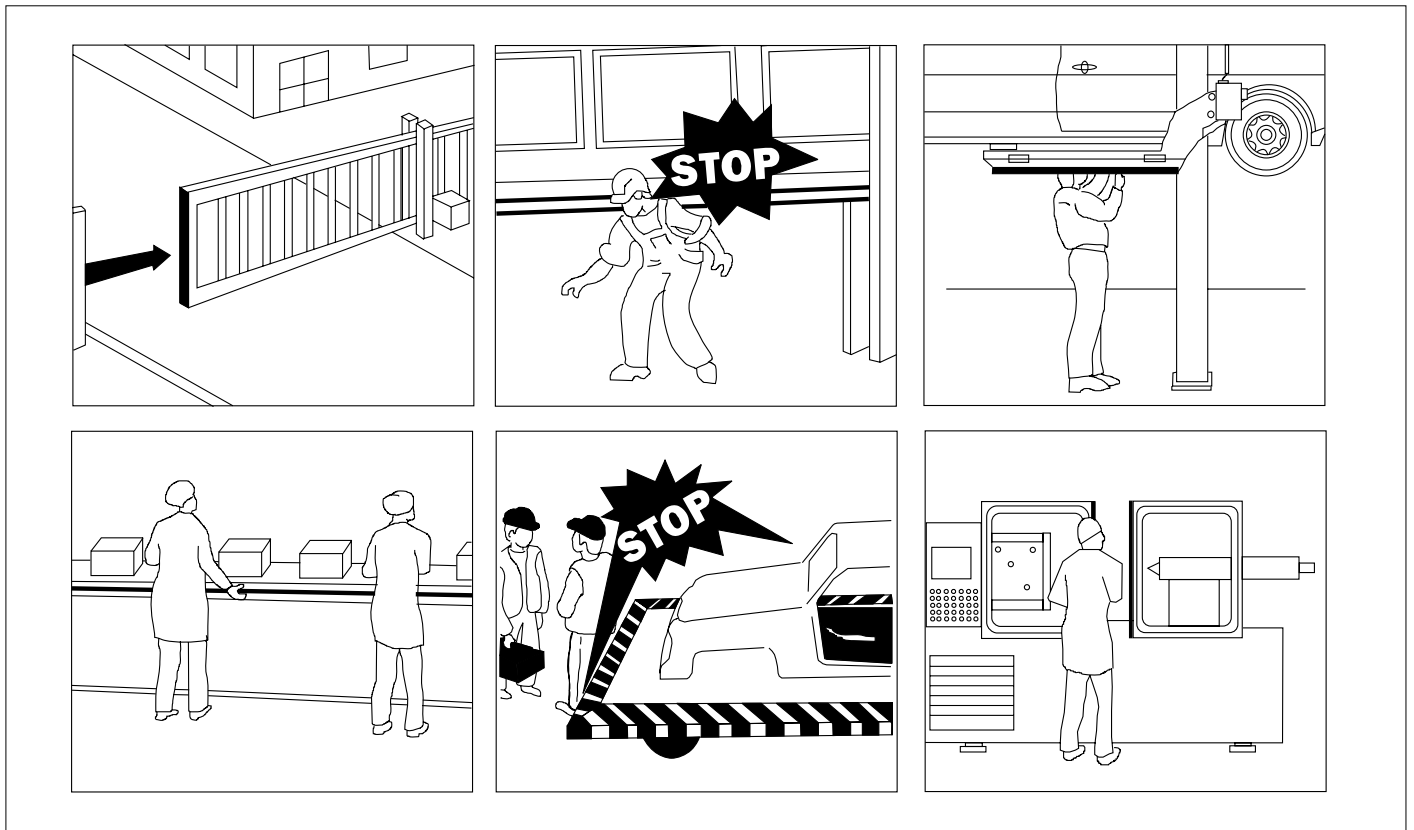

Safety contact edges

Approvals:



Application:

- Protection against squeezing accidents on moving machine parts and automatic doors.

Features:

- Can be connected to a safety relay, Vital or Pluto
- Supplied in customized lengths
- IP65
- Simple assembly on site
- Lengths up to 25 m.



General

Safety contact edges are employed to guard closing edges at possible crushing or shearing points. They are used in gates, machines and handling facilities to protect people and equipment. They consist of an aluminium support profile, the contactor profile and the safety contact edge.

Contact edges with cast-in contact strips

The safety contact edges GE series consist of a rubber profile with a cast-in contact strip. In the ends there are special connection plugs and terminal caps (End caps) adapted according to the rubber profile. The end components are glued together with a certain two component glue. The contact edge is mounted on an aluminium C-profile. The easy to handle subcomponents allows customer assemble of the GE contact edges, good for stock handling, but of course a preassembled contact edge can also be ordered. The GE series is available in EPDM design and can be supplied in lengths up to 25 m.

Contact edges with contact strips SKS 18

The safety contact edges GP series consists of a rubber profile with a separate safety contact strip (SKS 18) inside. The contact edge is mounted on an aluminium C-profile. The special design of profiles in EPDM or NBR rubber, protect the inner contact strip in the best way possible against damage and allows actuating angles to exceed 90°. GP series is normally supplied in lengths up to 6 m and is always delivered preassembled.

Material

EPDM design that has a good resistance to ozone and weather, especially against chemicals. NBR has good resistance to oil and petrol.

Supervision

The Safety Contact edge must be connected to a suitable two input channel Safety Relay. e.g. ABB Jokab Safety type RT6/RT7/RT9 which provides all necessary monitoring of the contact edges activation and detection of cable faults. The twin cable connection makes it possible to connect several contact edges in series.

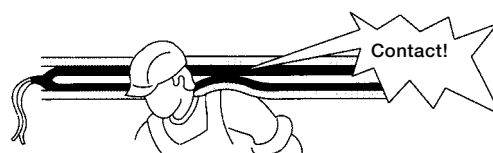

Contact edges GP - General

The safety contact edges GP series consist of a contact strip, SKS 18. This is the actual contactor that is located inside the safety contact edge. The safety contact strip consists of a homogeneous highly insulating outer EPDM material and has two internal conducting contact surfaces. The conducting elastomer contains two copper wires that provide low-resistance detection even in lengths exceeding 100 m. Because of the contact points, the safety contact edge has approximate 20 mm of inactive length at each end.

To provide protection against damage and to enable its proper use, the safety contact strip is inserted into the switching chamber of the rubber profile. The rubber profiles (EPDM or NBR) are then permanently sealed with a special elastic adhesive and end caps to make them watertight. The rubber profile is then mounted on the aluminium profile. The contact strip together with the rubber profile makes the GP safety contact edge.

Technical data - SKS 18

Outer material	EPDM, electrical insulation >30 Mohm
Inner material	EPDM, electrical elastomer with reinforce copper wire
Conductivity	60 ohm / 100 meters
Contact resistance	approx. 50 ohm
Max. electrical load	24 V / 100 mA
Max. applied pressure	6.5 N/cm ²
Dimensions	18 x 6 mm

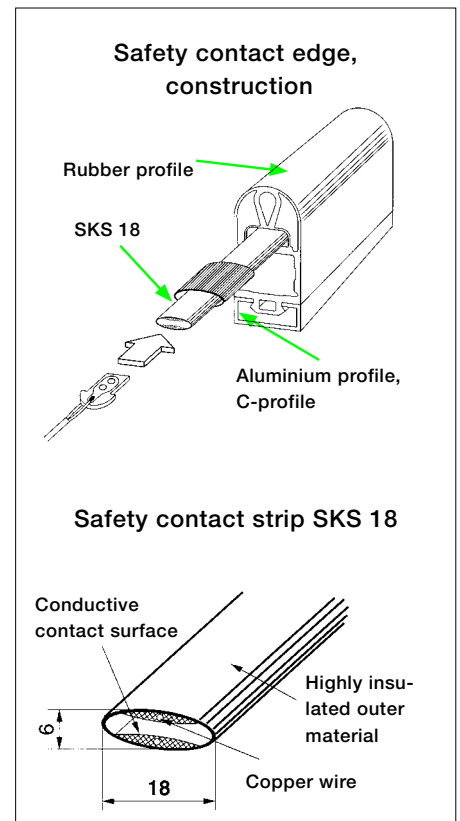

Contact edges GE - General

Inside the GE contact edge there is a cast-in contact strip that consists of two conductive alternating surfaces on the inside and a highly-effective insulating shell. There are two conductive wires in the contact surfaces that allow for low ohm measurements even when the contact edge has an extended length. The cast-in contact strip is protected against damage by the surrounding chamber. The cast end plugs ensure a permanent contact from the conductive surfaces in the contact strip. A special flexible adhesive is used to make the connector ring watertight.

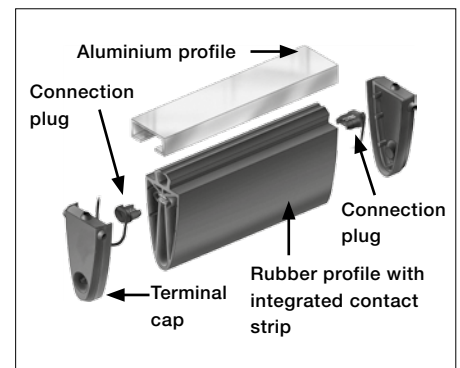

Technical data - Rubber profiles

Type		GP 25-25	GP 25-40	GE 25-25	GE 25-45
Fixing Profile		AL 25-14	AL 25-14	AI 25-14	AI 25-14
Material		EPDM/NBR	EPDM/NBR	EPDM	EPDM
Length max (m)	(1)	6(10)	6(10)	25	25
Weight (g/m)		370	480	510	770
Weight incl. C-Profile (g/m)		690	800	820	1080
Activation force (N)	(2)	34/37	39/52	64,1	69,1
Actuating distance (mm)	(3)	8.0/7.5	9.4/9.7	4,7	6,73
Braking distance (mm)	(3)	7.2/5.9	10.2/9.5	6.48	20.73
Max. actuating (°)	(4)	2x 45°	2x 60°	2x20°	2x20°

- (1) 10 m lengths of GP edges on request
- (2) Measured with (Ø 80 mm test specimen), 10 mm/s
- (3) Measuring speed 10 mm/s
- (4) Not including DIN 31006-2 (GS - BE - 17)

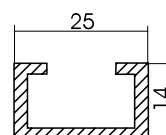

The selected contact profile should be mounted using a suitable aluminium C profile.

NOTE! Contact us for other profile sizes.

Technical data - Contact edges

Article number	
GP – Contact edges including aluminium profile	
GP 25-25 EPDM per meter	2TLA076025R2500
GP 25-25 NBR per meter	2TLA076125R2500
GP 25-40 EPDM per meter	2TLA076025R4000
GP 25-40 NBR per meter	2TLA076125R4000
Cable, production cost	
2+2 m cable	2TLA076009R0100
5+5 m cable	2TLA076009R0500
7+7 m cable	2TLA076009R0800
10+10 m cable	2TLA076009R1000
Contact us for more options	
Article number	
GE – Contact edges	
GE 25-25 EPDM per meter	2TLA076005R0200
GE 25-45 EPDM per meter	2TLA076005R0400
Connection plug with:	
2.5 m cable	2TLA076005R4400
5 m cable	2TLA076005R4500
10 m cable	2TLA076005R4600
resistor 8.2kΩ	2TLA076005R4700
End cap	
End cap for GE 25-25	2TLA076005R6200
End cap for GE 25-45	2TLA076005R6100
Others	
Al 25-14 aluminum profile	2TLA076002R0200
Prod. cost GE (when ready made)	2TLA076008R0000
Accessories	
Glueing set small 5 gr/5 ml	2TLA076005R7600
Glueing set large 20 gr/10 ml	2TLA076005R7700
Scissor	2TLA076005R8500
Plug insert too	2TLA076005R8600
Mechanical load max ¹	500 N
Actuating angle (DIN)¹	2x 20°
Mechanical life²	10 ⁵
Max. operate temp. range²	-20C° to +55°C
Max. temperature range	-25°C to +70°C
Protection classification	IP65
Max. electrical load	24 VDC 100mA
Resistance	0.6 Ohm/m
Conductors	GP: 2x 0.38 mm ² GE: 2x 0.34 mm ²
Conductors insulation material	GP: PVC GE: PUR matte black

¹ According to DIN 31006-2 (GS - BE - 17)

² Not including DIN 31006-2 (GS - BE - 17)

Ordering Contact edges

GP

When ordering a Contact edge GP it's made out of two parts. One article with production cost and cables and one article with type of Contact edge in meter. Always specify length of safety edge.

Example (complete and assembled):

- 1 pcs GP 25-25 EPDM, length 0.25 m, 5+5 m cable =
- 0.25 m of 2TLA076025R2500 (Contact edges+alu.profile)
- 1 pcs of 2TLA076009R0500 (cables and assemble)

GE

When ordering a Contact edge GE it's necessary to order every part specifically. Type of contact edge (in meter), aluminium profile (in meter), connection plugs (one for each end) and end caps (one for each end). If desired it can be assemble by ABB Jokab Safety, for a production cost. Always specify length of safety edge. Accessories for GE is ordered separately.

Example (complete and assembled):

- 1 pcs GE 25-45 EPDM, length 1.35 m, 2.5+5 m cable =
- 1.35 m of 2TLA076005R0400 (Contact edges)¹
- 1.35 m of 2TLA076002R0200 (Aluminum profile)²
- 1 pcs of 2TLA076005R4400 (2.5 m cable)³
- 1 pcs of 2TLA076005R4500 (5 m cable)⁴
- 2 pcs of 2TLA076005R6100 (End cap)⁵
- 1 pcs of 2TLA076008R0000 (Prod. cost GE)

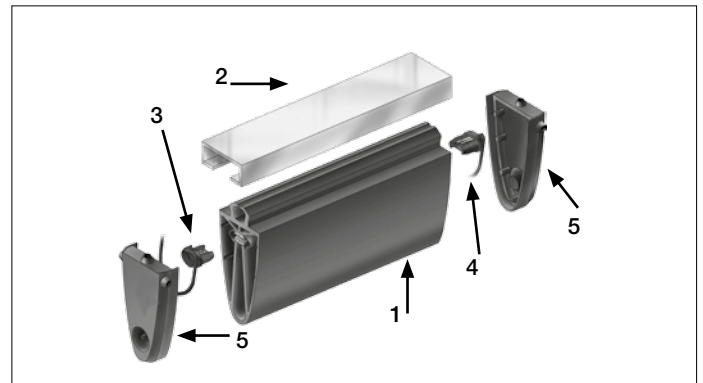

Safety bumpers



Approvals:



Application:

- Protection against squeezing accidents on moving machine parts and automatic doors.

Features:

- Can be connected to a safety relay, Vital or Pluto
- Customized lengths
- Customized shape
- IP65
- Lengths up to 3 m

Safety bumpers

Safety bumpers are safety equipment on transport vehicles, FTS vehicles, high-reach forklifts, freely moving systems, and everywhere where the safety systems require larger form alterations. When running against an obstacle, the short response time of the bumper initiates an immediate controller stop, while the bumper's soft foam core provides a long braking and run out path. This provides optimum protection for individuals and materials. The exterior surface is available as PU or NBR rubber. Standard colours for the PU exterior are either black or black with yellow stripes. The NBR rubber exterior is black on which yellow stripes can be applied.

The principle

The contact function of the ABB Jokab Safety bumper consists of the safety contact strip SKS 18 being actuated by a special mechanical construction. This construction, which is protected by a large foam cushion, is inserted and glued to the carrier aluminum profile. The foam rubber is covered with a polyurethane or NBR skin. By utilising this construction the bumper gives a stop signal when impacted from all directions with soft sides. The bumpers are delivered mounted to the carrier profile in ordered lengths (0.2 m – 3 m).

Supervision

The Safety bumper must be connected to a suitable two input channel Safety Relay, e.g. ABB Jokab Safety type RT6/RT7/RT9 which provides all necessary monitoring of the bumpers activation and detection of cable faults. The twin cable connection makes it possible to connect several bumpers in series.

1. Polyurethane exterior
2. Foam core
3. Carrier profile
4. Mounting profile
5. Sensing element

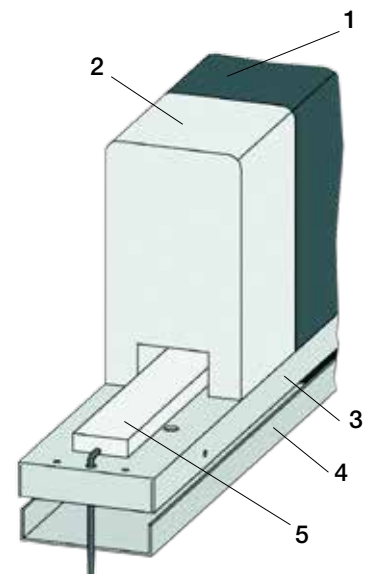

Technical data - Bumpers ASB

Article number	
Bumper base price	2TLA076200R0000
53/100 black	2TLA076200R0100
100/200 black	2TLA076200R0200
150/300 black	2TLA076200R0300
200/400 black	2TLA076200R0400
53/100 black/yellow	2TLA076200R0500
100/200 black/yellow	2TLA076200R0600
150/300 black/yellow	2TLA076200R0700
200/400 black/yellow	2TLA076200R0800
53/100 NBR black	2TLA076200R0900
100/200 NBR black	2TLA076200R1000
150/300 NBR black	2TLA076200R1100
200/400 NBR black	2TLA076200R1200
100/200 NBR black/yellow	2TLA076200R1500
Contact us for more options	
Dimensions	in accordance with the illustration, or special dimensions
Actuating distance	~20% of height
Braking distance	>50% of height
Actuating force [N]	<150 N with round body 80 mm <300 N with test object 45 x 400 mm
Mechanical life	>10 ⁵
Protection class	IP65
Ambient temperature	0° to +60°
Chemical resistance	
Oil, grease	good
10% acid	resistant
10% alkaline (caustic) solutions	resistant
Connection	20 cm with M8 male connector on one side 20 cm with M8 female connector on one side
Cable (included)	1 x 5 m with M8 male connector; 2 x 0.25 mm ² PU covered 1 x 5 m with M8 female connector; 2 x 0.25 mm ² PU covered

Ordering Safety bumpers

When ordering a Safety contact bumper it's made out of two parts. One article with production cost (base price) and one article with type of bumper in meter. Always specify length of the Safety contact bumper. Bumpers can be supplied in lengths of up to 3000 mm.

Example (complete and assembled):

- 1 pcs 150/300, black/yellow, length 2.1 m =
- 2.1 m of 2TLA076200R0700 (bumper+alu.profile)
- 1 pcs of 2TLA076200R0000 (base price)

Lengths and Connection

The ASB Safety bumper is available in lengths up to 3,000 mm. Wiring outputs are located at each end of the bumper. Special designs available on request.



X = Bumper height, Y = Bumper width, Z = Bumper length

Dimensions/Shapes

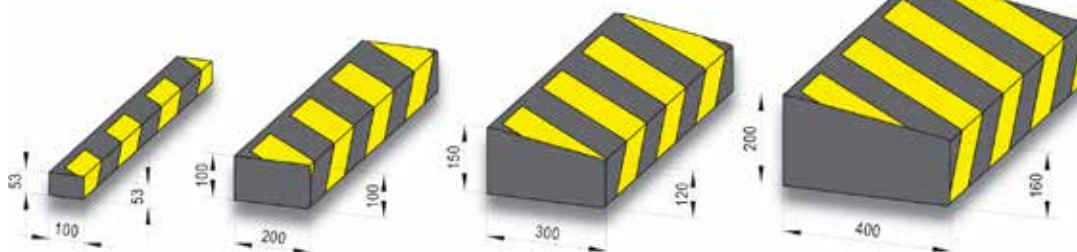

Special designs and special available on request

Safety mats

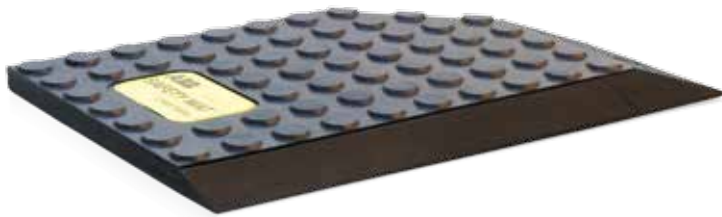

Approvals:



Safety mats for

- Personal protection within the dangerous areas around presses, robots, production lines, machines etc.

Features:

- Can be connected to a safety relay, Vital or Pluto
- Very durable
- IP65

Personal protection within dangerous areas

The ASK Safety mat is used for safeguarding sections within the dangerous areas around presses, robots, production lines, machines and other types of active equipment. When connected to a suitable monitoring system, stepping on the Safety Mat will immediately be detected causing dangerous machine movements to be stopped. This is made possible by the detection of electrical contacts closing within the sandwich construction of the mat. The safety mats offered by ABB Jokab Safety are available in two version, with our without a cast-in moulded ramp rail. Custom made size or shapes of the Safety mats can also be offered. Mounting to the floor can be realized with optional aluminum ramp rails RS14 or BS14 (for mats without moulded ramp rail).

Mat construction

The basic construction of the Safety mat is made up of a sandwich construction. The pressure contact switch consist of two conducting plates which are separated from each other by a proprietary isolating layer. The internal switching plates are cast into a durable polyurethane material to protect against moisture, and are then covered with a top layer of slip-free rubber. This surface provides excellent resistance against oil, water and grease. Optional surfaces in aluminum or stainless steel can be placed on the mat surface in areas where high mechanical demand. Two cable exits are provided, that consist of one M8 male plug and one M8 female plug in the standard construction (Optional cable exits are available upon request).

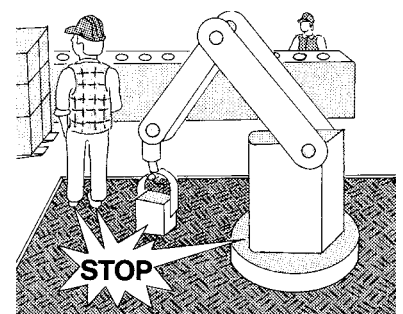
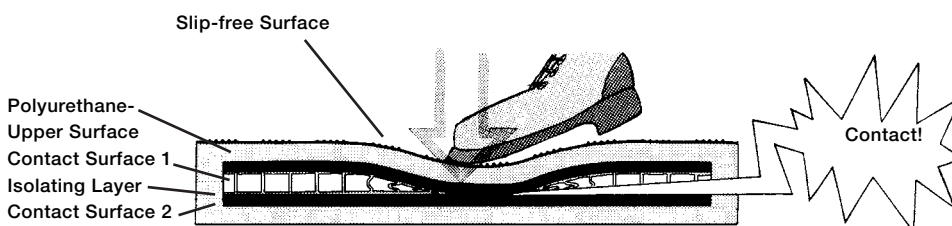

Safety distance - Safety mat as per EN ISO 13855

If a safety mat is used as entry protection, the smallest permitted safety distance between the hazardous area and the outer edge of the mat (seen from the hazard) is calculated using the formula from EN ISO 13855.

$$S = (K * T) + C$$

S = smallest permitted safety distance in mm
 K = body speed (velocity of propagation 1600 mm/s)
 C = additional distance in mm based on the intrusion of the body into the risk zone before the protection device is actuated (1200 mm applies for safety mats).

i.e.

$$S = (1600 * T) + 1200$$

Surface layer - Safety mats

Safety mats are normally supplied with a dotted polyurethane non-slip surface layer that withstands tough conditions very well (oil, acid or caustic substances) and has anti-slip properties. If required, other patterns can be supplied, or for special requirements even other materials, such as NBR rubber or chequer plating in aluminium or stainless steel. Safety mats can also be supplied without a surface layer, to have a full coverage rubber sheet glued on during installation. Please contact us for more information about these alternatives.

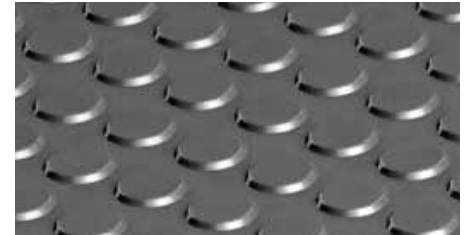

Edge Trim - Safety mats

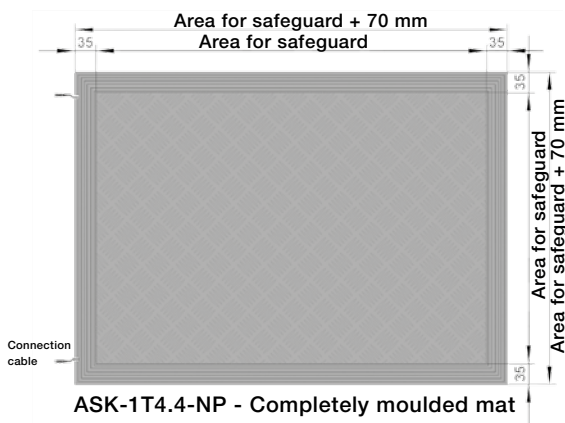

ASK-1U4.4-NP - Completely moulded mat without moulded ramp rail. Ramp rail in aluminum profile (RS14).

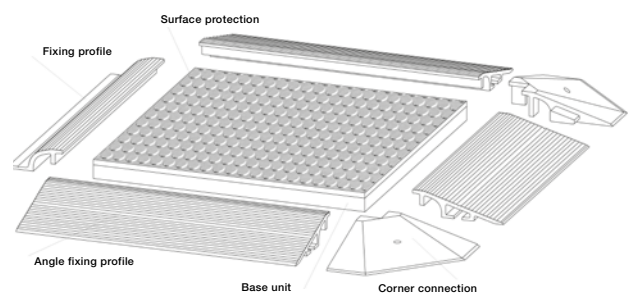
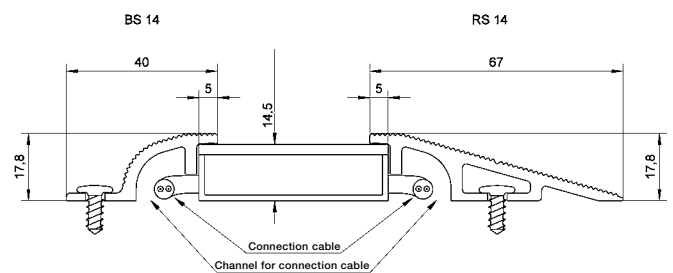

Edge trim RS14

Eliminates vertical edges and attaches the Safety mat to the floor. Also provides protection and channel for connection cables.

Profile BS14

Best for use on the side nearest the machine. Permits a shorter distance from, for example a wall.

Corner trim

Can be used between two RS 14 profiles as an alternative to mitre cutting of profiles.

Technical Data - Safety mats

Article number ASK-1U4.4-NP standard no ramp rail**	
1000 x 750 mm*	2TLA076310R0500
1000 x 1000 mm*	2TLA076310R0600
1000 x 1500 mm*	2TLA076310R0700
ASK-1U4.4-NP custom made no ramp rail**	
Base price	2TLA076301R0000
Cut to size (m ²) *	2TLA076301R0500
ASK-1T4.4-NP standard with molded ramp rail**	
1000 x 750 mm*	2TLA076310R1000
1000 x 1000 mm*	2TLA076310R1100
1000 x 1500 mm*	2TLA076310R1200
ASK-1T4.4-NP custom made with molded ramp rail**	
Base price	2TLA076301R0200
Cut to size (m ²)*	2TLA076301R0600
Accessories	
Cable 2.5 m M8 Male + M8 Female	2TLA076900R3200
Cable 5 m M8 Male + M8 Female	2TLA076900R3300
Edge trim RS14	2TLA076300R0500
Profile BS14	2TLA076300R0800
Corner trim	2TLA076300R0900
Cutting cost BS14 and RS14	2TLA076300R0800
Maximum area	One mat = 2350 x 1350 mm (relation max 3:1) Several mats = 10 m ²
Minimum size	100 x 100 mm
Height	max 14.5 mm with slip-free surface
Inactive area	Nominally 10 mm from Mat edge
Switching force	150N (Round body 80 mm)
Maximum pressure	2000 N over ø 80 mm
Material	Black polyurethane, other colours on request
Protection class	IP65
Ambient air temperature	0°C to +60°C
Chemical resistance	
Oil, grease	good
10% acid	resistant
10% alkaline (caustic) solutions	resistant
Connection	20 cm with M8 male connector on one corner 20 cm with M8 female connector on one corner
Cable (included)	1 x 5 m with M8 male connector; 2 x 0.25 mm ² PU covered 1 x 5 m with M8 female connector; 2 x 0.25 mm ² PU covered
Mechanical life	> 1.5x10 ⁶ load shifting

* Incl 5 + 5 m cables

**Size applies for safeguarded area

Ordering custom made Safety mats

When ordering a custom made mat, two articles need to be ordered. A base price and a square meter price. When ordering, the size of the mat need to be specified (X meter x Y meter).

Example:

- 1 pcs 0.450x1.15 m, normal surface with molded ramp rail=
- 0.518 m² of 2TLA076301R0600 (ASK-1T4.4-NP custom made)
- 1 pcs of 2TLA076301R0200 (base price)

Electrical connections

Safety contact edges, Safety bumpers and Safety mats

Contact edge, bumper or safety mat should be used with a suitable monitoring unit (e.g. ABB Jokab Safety safety relays RT6, RT7A/B, RT9, Vital with Tina 6A or Pluto safety-PLC).

The monitoring unit monitors the functionality of the contact protection and detects any breaks or short-circuits in the lines. Several crush protection units can be connected in series while still retaining the same level of safety.

When pressure is applied, the active surface of the contact area in the contact protection is closed and the safety output on the monitoring unit trips. A stop signal will be sent to the machine's safety circuits preventing any dangerous movements.

NOTE! If alternative units are used rather than the recommended ABB Jokab Safety relays, it is essential that the user checks their suitability with ABB Jokab Safety before use. Failure to do so may result in incorrect operation and/or damage to the safety bumpers and invalidate warranty.

HK7601A – Connection contact protection for safety relay RT6

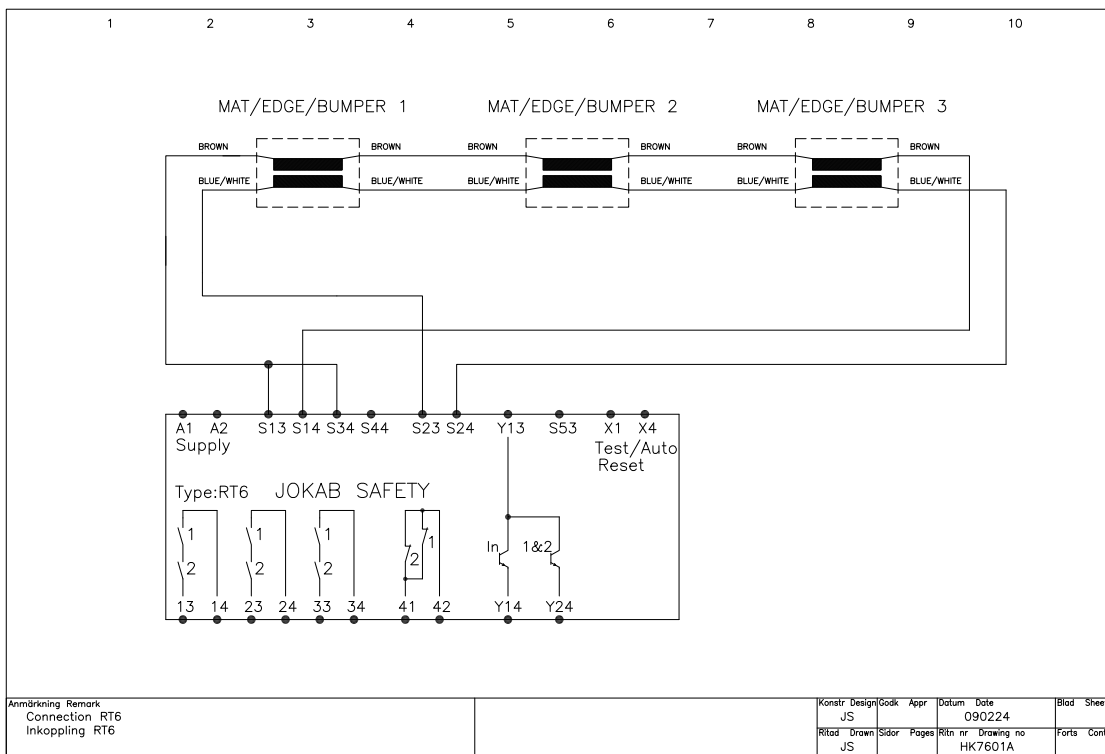



Fencing system

Quick-Guard and Safety Roller Door

Quick-Guard® fencing system	13/3
Quick-Guard® is supplied in three ways	13/6
Quick-Guard® Express	13/7
Quick-Guard® Express - can be ordered in sections	13/8
Quick-Guard® standard and SafeCAD	13/11
Assembly using NL2 and NL3 Net-locks on welded mesh	13/13
Dimensions for aluminium profile lengths and panels	13/14

Components

Aluminium profiles	13/15
Fittings	13/18
Door Components	13/20
Fitting for Switches	13/28
Terminal Caps and Strips	13/30
Accessories	13/31
Infill materials	13/32

Safety Roller Door

Safety Roller Door	13/34
--------------------	-------

Quick-Guard®

Fencing system



Quick-Guard Standard assembled with mesh.



Quick-Guard Standard with black and transparent Polycarbonate in-fill panels as used for medical applications.



Quick-Guard Express with few components and easy to angle at up to 45°.

Adaption and Modification

Quick-Guard is a very flexible fencing system consisting of a minimum of different components, e.g. aluminium profiles, patented brackets, net-locks, mesh, solid or noise reduction panels. Using these components there are almost no limitations as to what can be built. Quick-Guard fencing costs little to assemble and modify.

Assembly

Due to our patented screw-lock system, we can supply all brackets pre-mounted with fixing screws and nuts. No holes need to be drilled in the profiles and all cutting is straight. This makes assembly and modification very easy.

Two versions of Quick-Guard

The Quick-Guard fencing system is available in two versions, Quick-Guard (Standard) and Quick-Guard Express which also can be combined. The fencing systems are also easy to adjust when production equipment is modified and/or moved.

Proposal and ordering

By utilising our AutoCAD-based SafeCAD application we are able to make system designs in 3D very quickly. Drawings, cutting lists, etc. are generated from SafeCAD and the drawings can also be used for installation purposes.

Our policy - To create systems that are environmentally friendly and provide ergonomic working conditions

Quick-Guard is environmentally friendly. All components in the Fencing System can easily be disassembled and reused. All materials in the Fencing System are 100% recyclable. Quick-Guard can also provide a pleasing ergonomic working environment.

A flexible and stable fencing system which is easy to install



Fixings with pre-assembled screws and nuts mean easy assembly

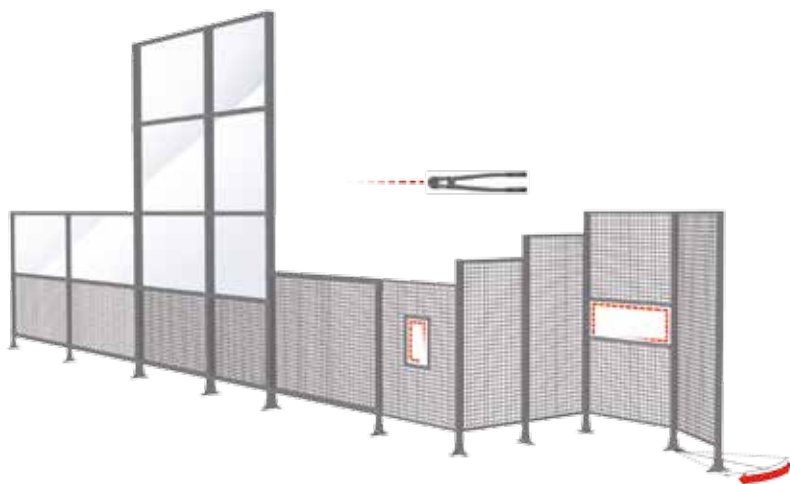

Width, length and height adapted and easily changed according to needs



Choose from a large selection of hatches and doors

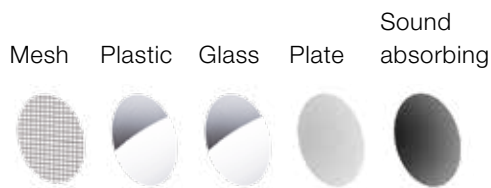
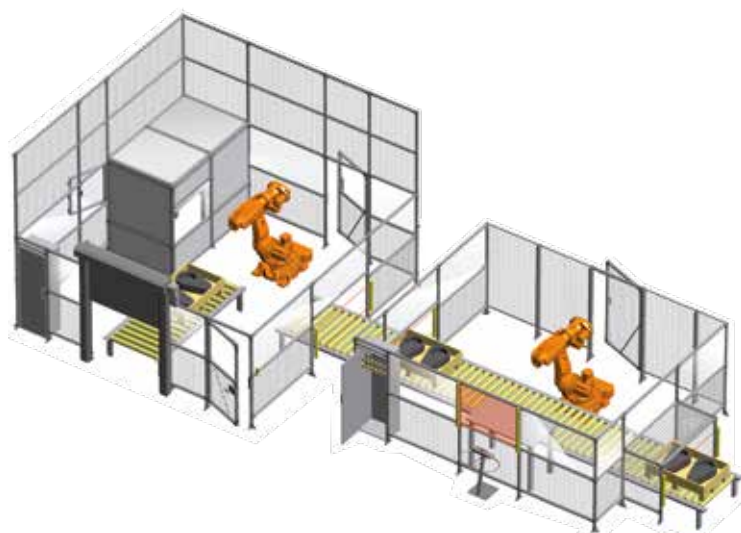

What does the standard say?

EN ISO 13857 applies as safety distance for the risk zones. The standard includes the dimensions that apply for safety distances in various risk situations. The adjacent figure shows examples of dimensions for safety distances for two different fence heights where the risk of injury is relatively small when you reach in.

With respect to mesh, you specify a minimum distance of 200 mm (for people 14 and above) for opening size 40 x 40 mm. For shorter distances and for noise reduction we use solid panels. When the fence is to protect a robot cell, for example, the fence protection should be placed at a minimum distance of 500 mm between the fence protection and the moving machine part that reaches furthest out (as per EN 349). When test running or programming there must be a space between the fencing and any moving parts to ensure the operator does not become wedged between them.

For protection that needs to be mounted and removed again, for example for maintenance, the Machinery Directive requires that fasteners remain in place on the protection. We normally deal with this using interlocked doors/gates for faster and safer access.

Feel free to consult us about the requirements in regulations and standards.

Patented assembly function

The ABB Jokab Safety patented guide and locking method makes it simple to assemble and dismantle the fencing system. The nut has several advantages, it can easily be located into the profile and automatically positions itself when the screw is turned 90 degrees clockwise. When in this position the bracket being fixed can be adjusted as required and locked by turning the screw further clockwise. To remove the bracket the fixing screw is turned anti-clockwise until the nut is in line with the profile slot.

All fittings are supplied pre-assembled. Fittings that do not have a cast-in tab can be provided with a centring washer.

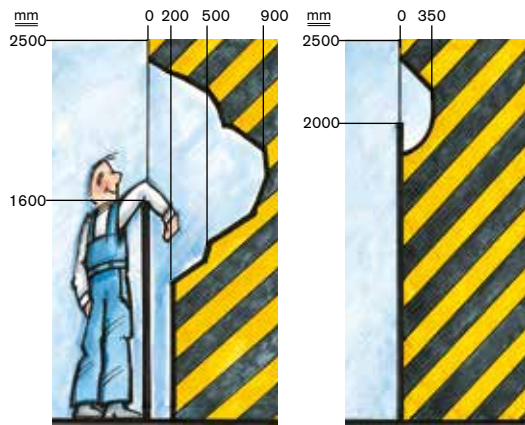

Safety distance for 1600 mm guarding with standard mesh. Safety distance for 2000 mm guarding with solid screens (e.g. polycarbonate sheet).

Safety distance for 1600 mm guarding with standard mesh. Safety distance for 2000 mm guarding with solid screens (e.g. polycarbonate sheet).

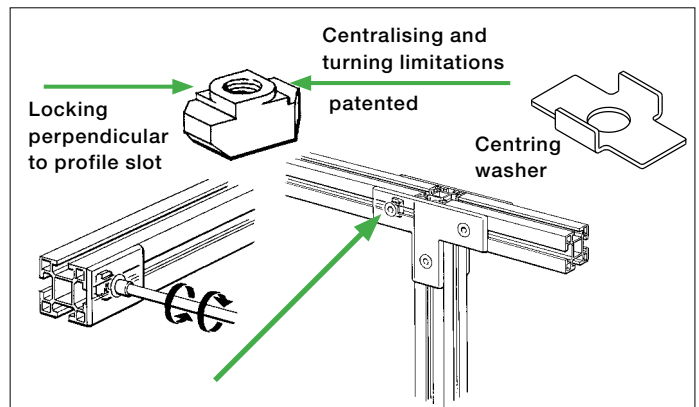

Mount the fixtures by first slackening the screw 3/4 turn anti-clockwise. Then tighten the screw clockwise in the usual way. The nut will then automatically mechanically lock the fixture into the profile.

Easy to adjust the position of fittings

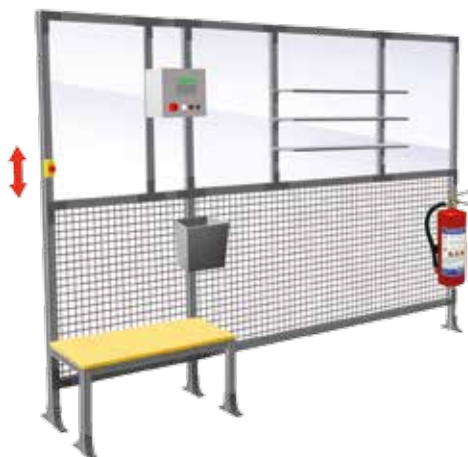

The T-slot and patented nut makes it easy to attach fittings to the fencing profiles

Quick-Guard®

Supplied in three ways

1. To be designed on site

You only order sections consisting of a few components. Then the fencing system is built on site. A manual mesh clipping tool, for easy cutting of the mesh, is provided with the delivery if needed.



To be designed on site.

2. Cut to size according to drawing

You give us a simple sketch or a AutoCAD® file of how you want the fencing system to look. We input this information into SafeCAD and design the fence in 3D. From this drawing, cutting and component lists and a quotation are generated automatically.

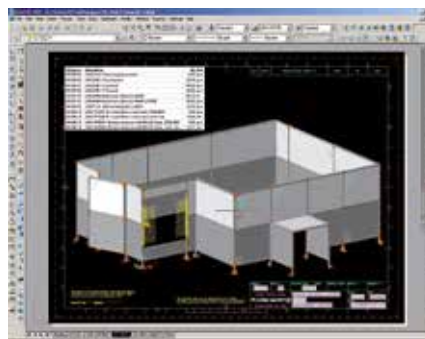

Cut to size according to drawing.

3. Pre-mounted or assembled on site

We can deliver full/partially pre-assembled fencing systems or we can assemble them on site.



Pre-mounted or assembled on site.

Quick-Guard® Express

- design directly on site

Quick-Guard E is installed quickly and cost effectively because it only consists of patented net-locks, welded mesh, panels of polycarbonate, u-profiles and fence posts (profiles with floor-brackets). All parts for Quick-Guard and pre-assembled doors are delivered immediately from stock. The few components of the fencing system make it easy for you to custom build and install the fencing system yourselves.

The strength of the fencing system originates from the fact that the welded mesh and/or panels of polycarbonate are 'locked' into the profile. The outer wire of the mesh is locked by uniquely designed 'netlocks' into the profile making the fixing virtually as strong as being welded. The polycarbonate panels are locked in with specially designed infill-locks which, according to our tests, have been as strong as the mesh net-lock system. If you want more stable fencing posts, you can choose a sturdier profile measuring 44 x 88 mm instead of the standard 44 x 44 mm profile.

It is always easy to combine Quick-Guard E with Quick-Guard standard to achieve a complete system. It is also easy to adjust and modify the guarding system when production equipment is modified and/or moved.

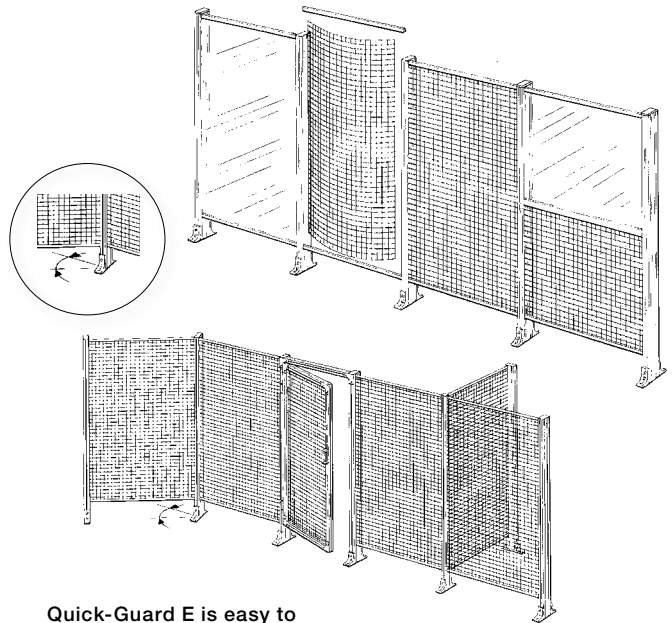

Quick-Guard E is easy to assemble and to angle 45°.

Assembly of Quick-Guard Express

1.

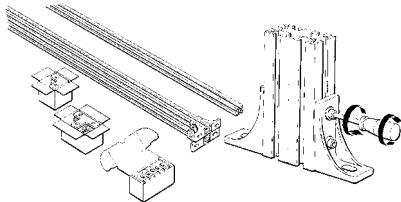

Premount floor fixtures on vertical posts. Mount fixtures by first slackening the screw anti-clockwise. Then tighten the screw clockwise in the usual way, the nut will then automatically locate into the correct position and mechanically lock the fixture into the profile. Make sure that the nut has turned correctly.

2.

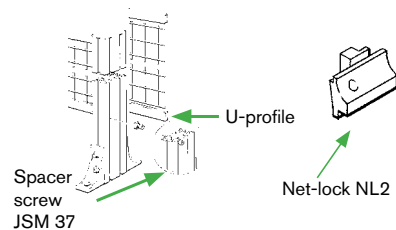

1. Mount a spacer screw 180 mm from the floor in the posts.
2. Attach the lower U-profile and mesh lock JSM NL2 to the mesh.
3. Push the mesh into the profile and fix the mesh with NL2 netlocks.
4. Fix top u-profile in place either before or after inserting the mesh.

3.

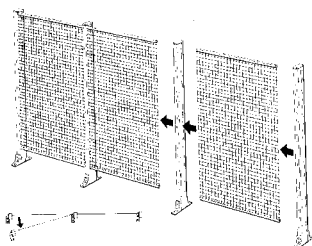

Assemble the next section. The distance between the posts can be adjusted some mm after the mesh is locked in with the Net-locks. The mesh can be angled up to 45° without using hinges (JSM 35-K).

4.

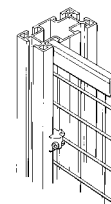

Lock the top of the mesh using NL3 netlocks; this way the mesh is secured, stabilised and electrically grounded. Grounding is needed when electrical devices or cables are assembled on the mesh.

Quick-Guard® Express

- can be ordered in sections

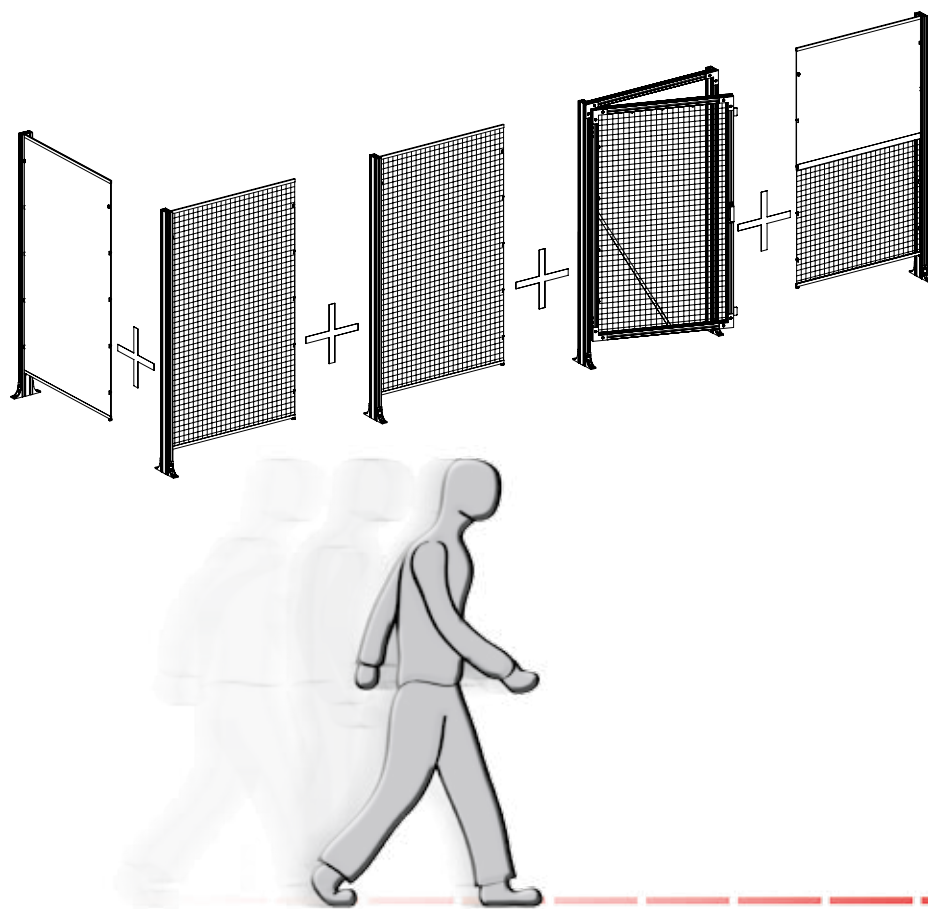

Quick-Guard Express can be ordered in different sections consisting of a few components. By adding the different sections, one person can easily install a Quick-Guard fencing system.

One person can easily assemble the Express sections. It is also possible to angle these sections up to 45 degrees angle. The mesh can easily be cut to the desired size with a simple clipping tool.

Measure the number of metres of fencing that are required and determine the number of doors. Our two standard sections have a cc width of 1100 mm and 1500 mm. The cc for the door is 1100 mm and fits anywhere the cc is 1100 mm between the posts.

If dimensions other than the standard dimensions are needed, just cut the mesh to the correct size with a bolt cutter.

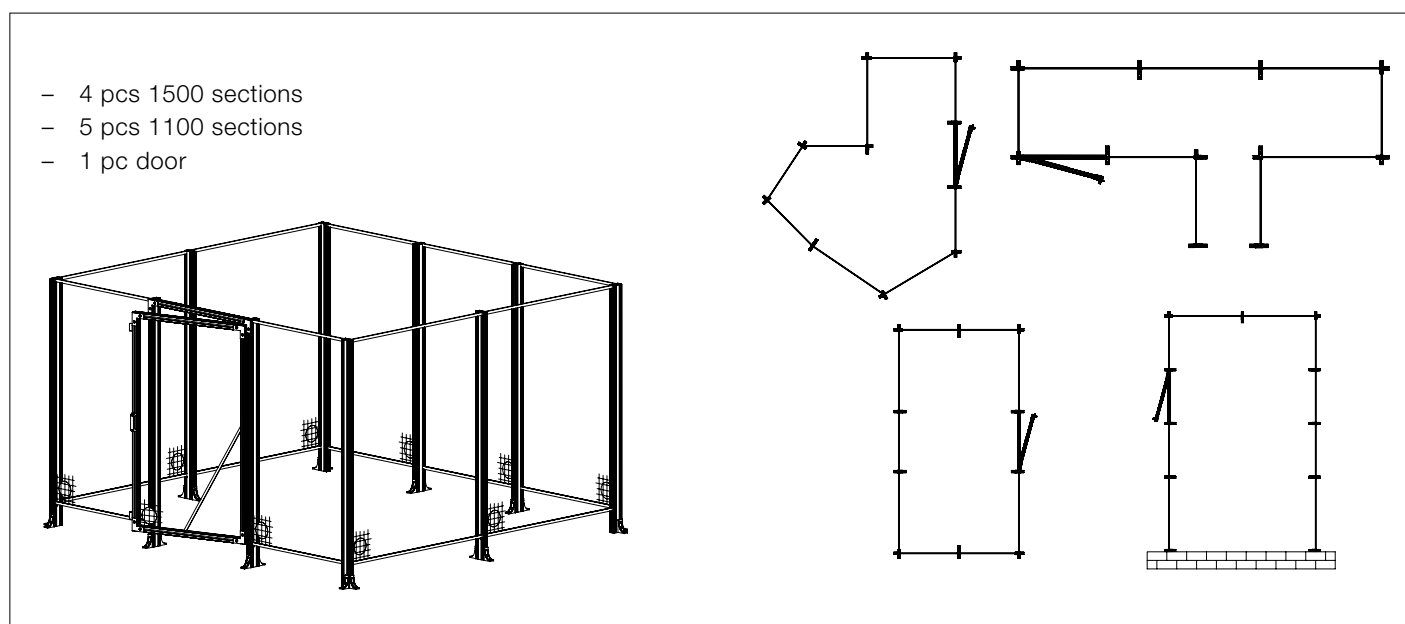

The same fencing sections can be erected in several ways.

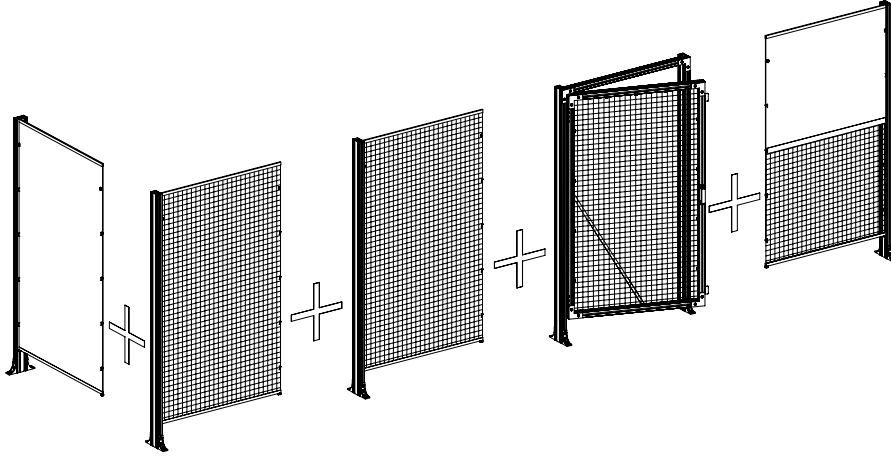
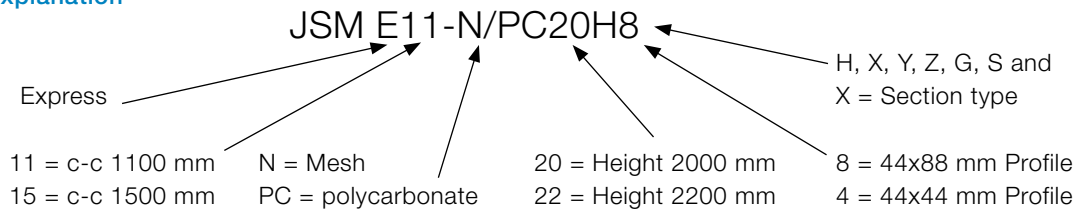

Designation explanation

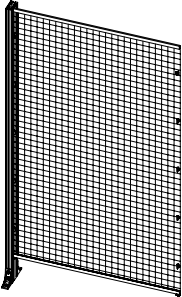

One person can easily assemble the Express sections. It is also possible to angle these sections up to 45 degrees angle. The mesh can easily be cut to the desired size with a simple clipping tool.

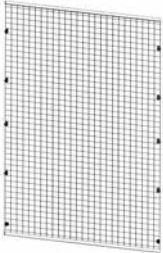
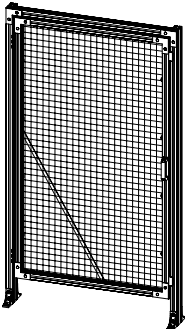
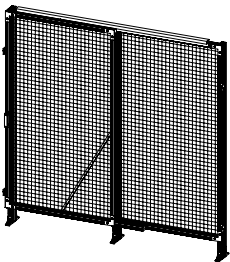
Image	Designation	Article number	Description
<p>Section X</p> 	<p>JSM E11-N14X4 JSM E11-N20X4 JSM E11-N20X8 JSM E11-N22X4 JSM E11-N22X8 JSM E11-N/PC20X8 JSM E11-N/PC22X8 JSM E11-PC20X8 JSM E11-PC22X8 JSM E15-N14X4 JSM E15-N20X8 JSM E15-N22X8</p>	<p>2TLA040106R0200 2TLA040101R0200 2TLA040101R0300 2TLA040102R0200 2TLA040102R0300 2TLA040104R0100 2TLA040105R0100 2TLA040101R5300 2TLA040102R5300 2TLA040106R1000 2TLA040101R0900 2TLA040102R0800</p>	<p>Components for an additional section with only one post. The height can be varied between 1400 mm or 2200 mm. The section is supplied unassembled.</p> <p>Included parts: Floorbracket, netlocks/panel locks, support screws, edge protection, Aluminum profile and welded steel mesh/panel sheet.</p>
<p>Section Y</p> 	<p>JSM E11-14Y4 JSM E11-20Y8 JSM E11-22Y8</p>	<p>2TLA040106R8000 2TLA040103R2100 2TLA040103R4100</p>	<p>Components for a complete post with floor bracket to finalize the additional sections. The height can be varied between 1400 mm or 2200 mm. The section is supplied unassembled.</p> <p>Included parts: Floorbracket, support screw, and Aluminum profile.</p>
<p>Section Z</p> 	<p>JSM E11-N14Z JSM E11-N20Z JSM E11-N22Z JSM E11-N/PC20Z JSM E11-N/PC22Z JSM E11-PC14Z JSM E11-PC20Z JSM E11-PC22Z JSM E15-N14Z JSM E15-N20Z JSM E15-N22Z</p>	<p>2TLA040106R0400 2TLA040101R0400 2TLA040102R0400 2TLA040104R0200 2TLA040105R0200 2TLA040106R5400 2TLA040101R5400 2TLA040102R5400 2TLA040106R0800 2TLA040101R1000 2TLA040102R0900</p>	<p>Components for a complete section without fence posts and floor brackets. The height can be varied between 1400 mm or 2200 mm. The section is supplied unassembled.</p> <p>Included parts: Netlocks/panel locks, edge protection and welded steel mesh/panel sheet.</p>
<p>Section G</p> 	<p>JSM E11-N14G JSM E11-N20G* JSM E11-N22G* JSM E11-N/PC20G JSM E11-N/PC22G JSM E11-PC14G JSM E11-PC20G JSM E11-PC22G</p> <p>* The door leaf is supplied pre-mounted.</p>	<p>2TLA040106R0500 2TLA040101R0500 2TLA040102R0500 2TLA040104R0300 2TLA040105R0300 2TLA040106R5500 2TLA040101R5500 2TLA040102R5500</p>	<p>Components for complete conventional door with outer profile 44x88 mm. The height can be varied between 1400 mm or 2200 mm. The section is supplied unassembled. The size of the door can easily be adjusted on site.</p> <p>Included parts: L-brackets, floorbrackets, netlocks/panel locks, handle, hinges, door stop, crossbar, aluminum profiles and welded steel mesh/panel sheet.</p>
<p>Section S</p> 	<p>JSM E11-N20S JSM E11-N22S JSM E11-N/PC20S JSM E11-N/PC22S JSM E11-PC20S JSM E11-PC22S</p> <p>JSM E15-N20S JSM E15-N22S</p>	<p>2TLA040101R0600 2TLA040102R0600 2TLA040104R0400 2TLA040105R0400 2TLA040101R5700 2TLA040102R5600</p> <p>2TLA040101R1100 2TLA040102R1000</p>	<p>Components for a complete sliding door with outer profile 44x88 mm. The height can be varied between 2000 mm or 2200 mm. The section is supplied unassembled. The size of the door can easily be adjusted on location.</p> <p>Included parts: L-brackets, T-brackets, floorbrackets, netlocks/panel locks, handle, suspension wheels, guiding components, door stop, crossbar, endcaps, aluminum profiles and welded steelmesh/panel sheet.</p>

Quick-Guard® standard and SafeCAD®

Order cut to length in accordance with drawing, pre-assembled or fitted on site.

Quick-Guard consists of a minimum of different components, such as aluminum profiles, patented assembly parts, net-locks, mesh, solid or noise reduction panels. Furthermore the cost for assembly and modification of the system is low. Thanks to our patented screw-lock system, we can supply all brackets pre-mounted with fixing screws and nuts. No holes need to be drilled in the profiles and all cuts are made straight. Assembly and modification is therefore very easy.

To be able to quickly and easily custom design practical safety solutions, we have developed a computer programme, SafeCAD. This is a 'plug-in' program for AutoCAD®. A simple sketch of the guarding system that is required is

used as the program input. The positions of doors and hatches, choice of mesh, polycarbonate, aluminum/steel sheet or noise reduction panels are typed in. The program automatically generates 3D drawings along with component and cutting lists. These drawings are also used as the basis for assembly/installation.

It is always easy to combine Quick-Guard Express with Quick-Guard to achieve a complete system. It is also easy to adjust and modify when the production equipment is modified and/or moved.

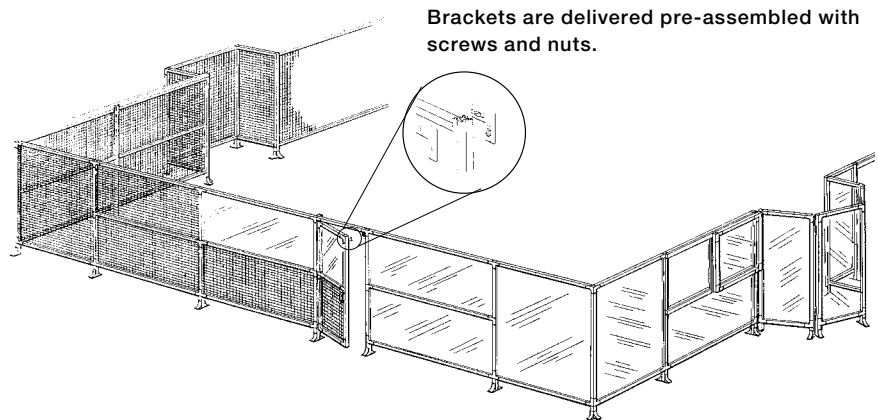

With SafeCAD® we can easily tailor your protection solution together

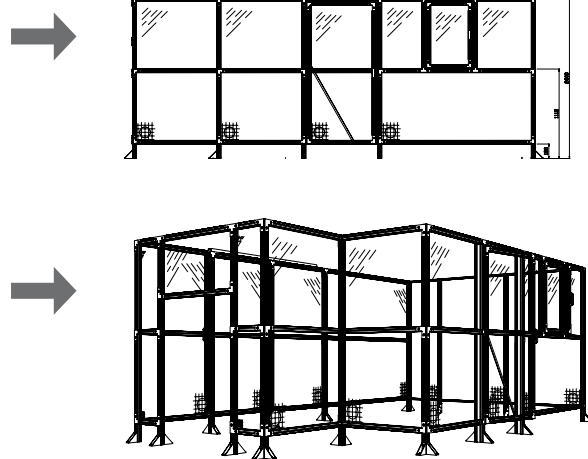

Example of component and cutting list print-outs from SafeCad.

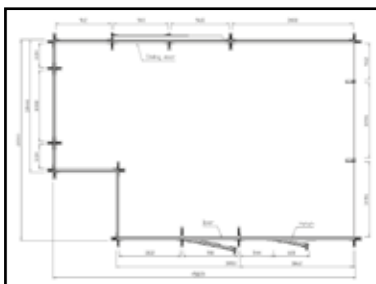

Article no.	Description	Qty	Length	Width	Sum.m ²
Quote					
40-030-06	JSM 30B-K Floorbracket	26,00			
40-030-07	JSM 32B-K L-bracket	72,00			
40-030-08	JSM 33B-K T-bracket	18,00			
Cutlist Polycarbonate					
40-039-10	JSM YPC5A1 Pc. sheet 5mm uncoloured 2020x864	1	864	2020	1,75
40-039-12	JSM YPC5A9 Pc. sheet 5mm uncoloured, cut to size	1	532	1020	0,54
40-039-12	JSM YPC5A9 Pc. sheet 5mm uncoloured, cut to size	1	756	504	0,38
Cutlist Welded Mesh					
40-040-13	JSM YN40W1 Welded steelmesh 40x40x3,5 black, 2020x864	1	864	2020	1,75
40-040-14	JSM YN40W2 Welded steelmesh 40x40x3,5 black, 1074x1816	2	1820	1074	3,91
40-040-16	JSM YN40W9 Welded steelmesh 40x40x3,5 black, cut to size	2	864	354	0,61
40-040-16	JSM YN40W9 Welded steelmesh 40x40x3,5 black, cut to size	1	864	804	0,69
40-040-16	JSM YN40W9 Welded steelmesh 40x40x3,5 black, cut to size	1	864	920	0,79
40-040-16	JSM YN40W9 Welded steelmesh 40x40x3,5 black, cut to size	2	864	932	1,61

Quick-Guard® Assembly - standard version



Assembly of the Quick-Guard® system is very easy. All components are very light in weight and ergonomic in design. This enables, in most cases, one person to be able to assemble both simple and complex structures with ease using very few different types of fixing components. All fixtures can be

mounted easily from “outside” by using the specially designed “locking nut” which can be located anywhere in the extrusion channel. The fixture components, by means of integral locating keys, ensure that correct angles are achieved and enable the number of bolts/nuts to be reduced to half the number that would otherwise be required.

1.

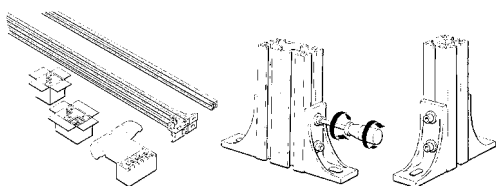

Premount floor fixtures by first slackening the screw anti-clockwise. Then tighten the screw clockwise in the usual way. The nut will then automatically locate into the correct position and mechanically lock the fixture into the profile.

2.

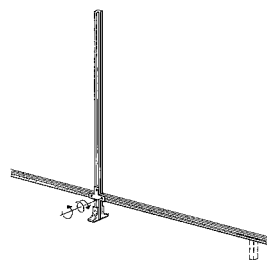

Attach lower horizontal extrusion between vertical posts. Use a spacer block to ensure the correct distance from the floor.

3.

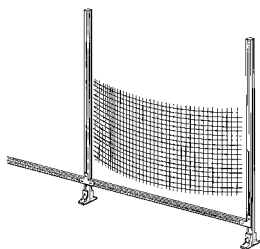

Insert infill panel and fix middle horizontal profile. The distance between the profiles is the width of the infill minus 20 mm.

4.

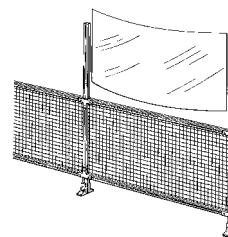

Insert top infill panel. Fix top profile with fittings on the top on both sides.

5.

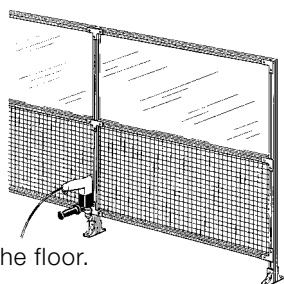

Fix the poles to the floor.

6.

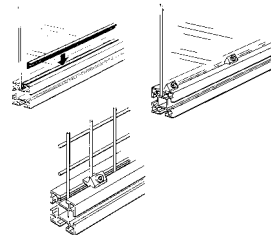

Secure infill sheet with plastic strip or Net-lock fixings. Easy, fast and quick. See more under Assembly of netlocks. If there is a risk of the robot striking the polycarbonate, JSM PL3 panel locks must be used.

Assembly using NL2 and NL3 Net-locks on welded mesh

NL2 Net-lock

The outer mesh wire is locked into the profile.

max 2 mm

When assembling the Net-lock NL2 it is first put into the profile as the drawing shows. Then the Net-lock is turned 90°. When cutting the welded mesh the wire ends should not be longer than two (2) mm.

NL3 Net-lock

Mesh with outer wire.

Mesh without outer wire.

max 2 mm

min 15 mm

The outer mesh wire is locked into the profile.

The Net-lock locks the mesh against the profile.

When assembling the Net-lock NL3 it is first put into the profile with the tabs on each side of the mesh wire. The screw is then tightened. When cutting the welded mesh the wire ends should be at least 15 mm to fit into the profile. NL3 must be used to lock the mesh into the slot.

Number of Net-locks Quick-Guard standard version

On Quick-Guard standard version NL3 is recommended as it can be used for mesh with or without an outer wire.

Number of Net-locks Quick-Guard Express

On Quick-Guard Express both Net-lock NL2 and NL3 can be used. For mesh edges without outer wire NL3 must be used instead of NL2.

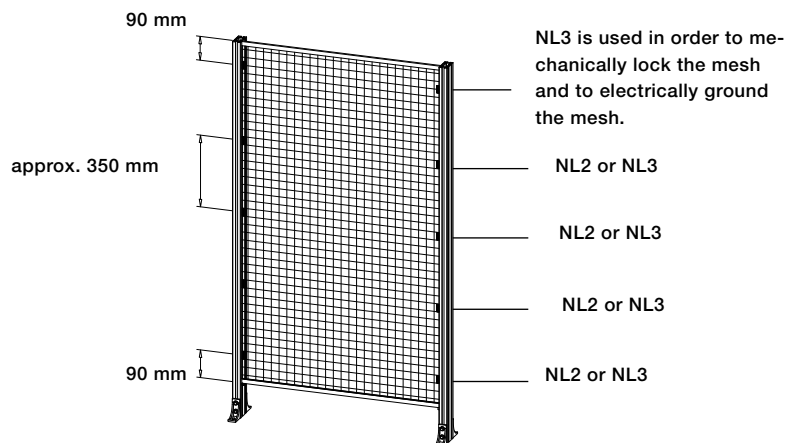
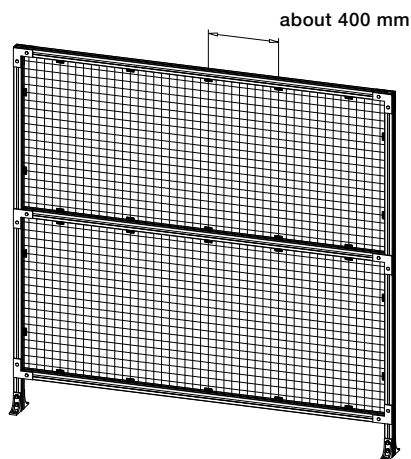

NOTE! On welded mesh without an outer wire NL3 must be used.

NOTE! On both Quick-Guard Standard and Quick-Guard E at least two NL3 should be used in order to mechanically lock the mesh and to electrically ground the mesh. NL3 should only be used on doors.

Fixing posts to the floor when mesh is required to be fitted at a later date.

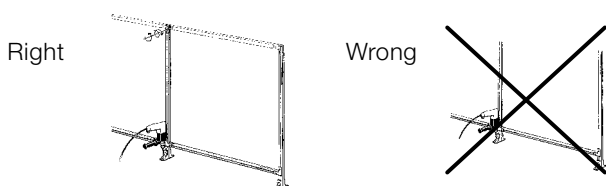

Temporarily mount at least two middle profiles before drilling and fixing posts to the floor. This method is used when infill mesh or panels are to be fitted at a later date.

Note! Never attempt to fix the posts to the floor without first connecting at least two middle profiles to ensure the posts are parallel to each other and vertical.

Dimensions

Aluminum profile lengths and infill materials

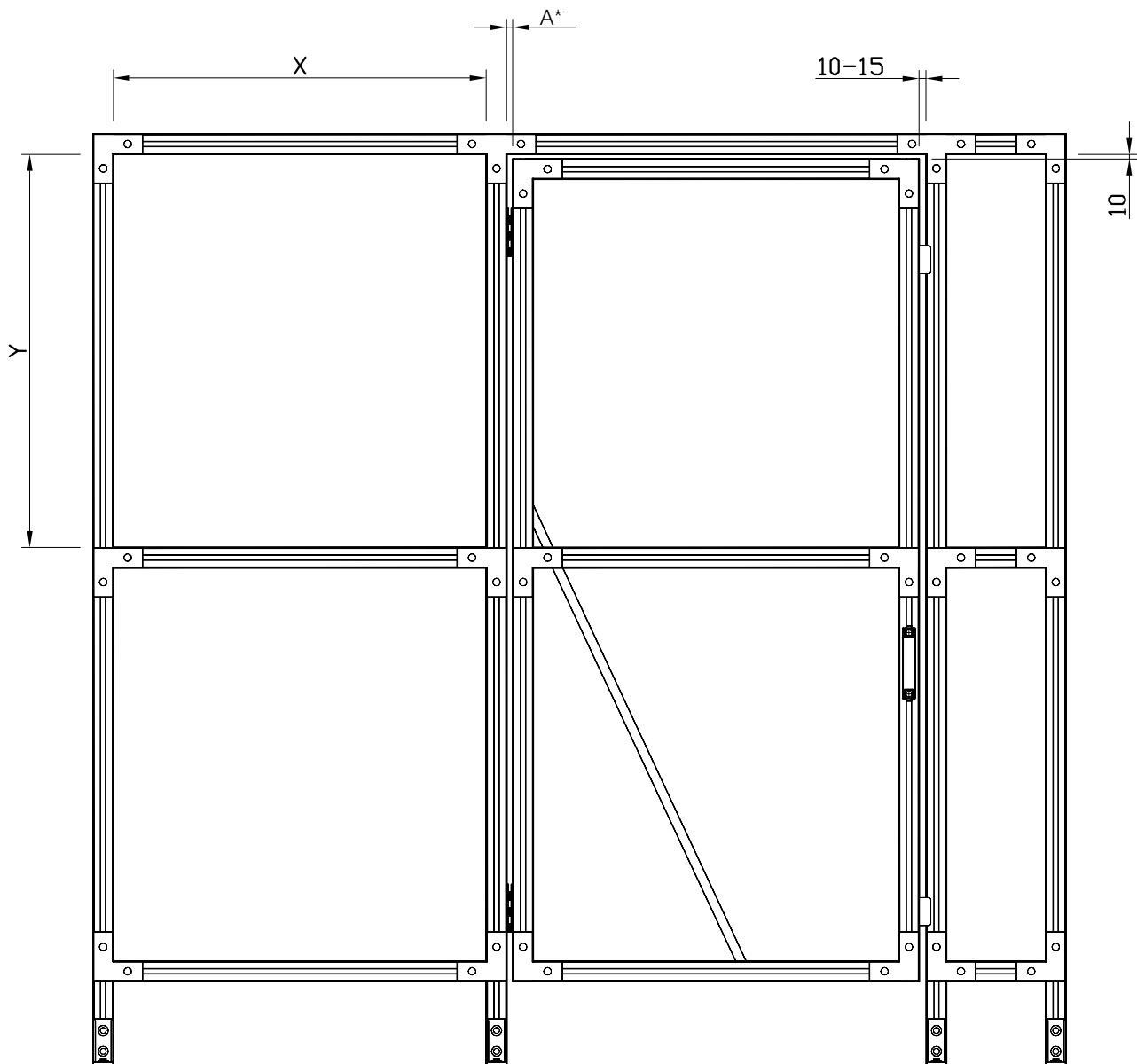

*A=13 (JSM D1A), A=1 (JSM D1C)

Material

Polycarbonate
 Welded mesh
 Steel panel
 Sound absorbing panel 25 mm
 Sound absorbing 50 mm
 Laminated glass
 Double Pc
 JSM AS1 Profile for 25 mm sound absorbing panel
 JSM AS3 Profile for 50 mm sound absorbing panel
 JSM AS2 Profile for 2x5 mm pc sheet

Width

X+20 mm
 X+20 mm
 X+20 mm
 X-37 mm
 X-37 mm
 X+15 mm
 2 pcs. X-7
 2 pcs. L=X
 2 pcs. L=X (mitred 2 x 45 degrees)
 2 pcs. L=X

Height

Y+20 mm
 Y+20 mm
 Y+20 mm
 Y-37 mm
 Y-37 mm
 Y+15mm
 2 pcs. Y-7
 2 pcs. L=Y-73
 2 pcs. L=Y (mitred 2 x 45 degrees)
 2 pcs. L=Y-33

Aluminum profiles

A wide range of aluminium profiles are available and include, fencing profile, guide rails, and cable ducting. The cable ducting is available in three sizes, and can be delivered with or without mounting holes. The cable ducting is easy to open and can be provided with end caps. Cover strips of plastic are also available, including fencing profiles making the entire groove cross section utilisable as 'installation conduit' for cables. The Aluminium profiles have integral "V" grooves to aid in centring any drilling that may be necessary.

Alloy: 6063 and 6060F22. Natural anodized aluminium 10µm

Fencing Profile

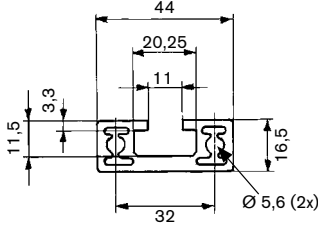
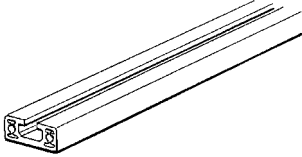
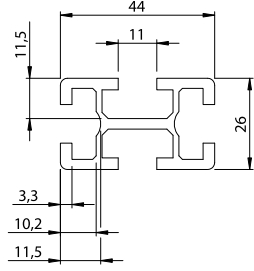
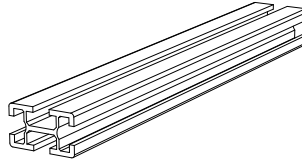
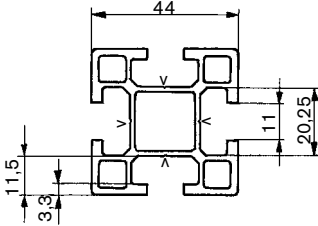
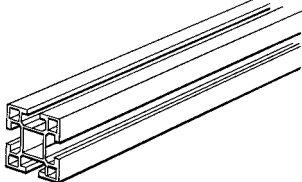
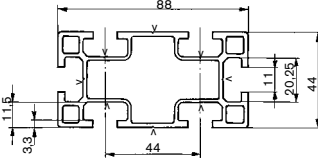
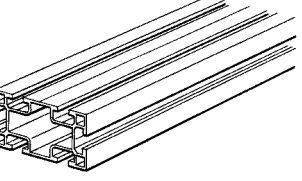
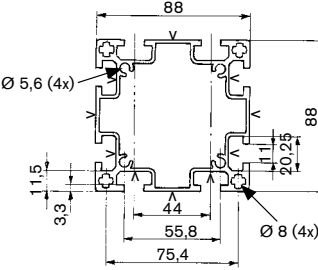
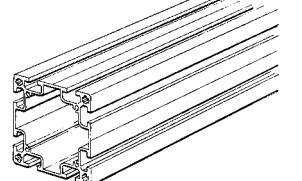
Designation	JSM A4416		
Article numbers	2TLA040037R7000 (cut to size) 2TLA040037R7400 (L=6000)		
Material	Natural anodized aluminium		
Dimensions	16.5 x 44 mm		
Designation	JSM A4426		
Article numbers	2TLA040037R7000 (cut to size) 2TLA040037R7400 (L=6000)		
Material	Natural anodized aluminium		
Dimensions	44 x 26 mm		
Designation	JSM A44A		
Article numbers	2TLA040037R3500 (cut to size) 2TLA040037R3600 (L=1100) 2TLA040037R9800 (L=1400) 2TLA040037R3700 (L=2000) 2TLA040037R3800 (L=2200) 2TLA040037R3900 (L=2400) 2TLA040037R4000 (L=2500) 2TLA040037R4100 (L=6000)		
Material	Natural anodized aluminium		
Dimensions	44 x 44 mm		
Order Unit	10 pcs/box		
Designation	JSM A4488A		
Article numbers	2TLA040037R4200 (cut to size) 2TLA040037R4300 (L=2000) 2TLA040037R4400 (L=2200) 2TLA040037R4500 (L=6000)		
Material	Natural anodized aluminium		
Dimensions	44 x 88 mm		
Order Unit	5 pcs/box		
Designation	JSM A8888		
Article numbers	2TLA040037R7500 (cut to size) 2TLA040037R7900 (L=6000)		
Material	Natural anodized aluminium		
Dimensions	88 x 88 mm		

Technical data – fencing profile

Typ	Vikt (kg/m)	Angular moment		Flexural resistance	
		I _x (mm ⁴ ×10 ⁴)	I _y (mm ⁴ ×10 ⁴)	W _x (mm ³ ×10 ³)	W _y (mm ³ ×10 ³)
JSM A4416	1.040	1.1	7.6	1.19	3.43
JSM A4426	1.023	3.2	7.4	2.47	3.36
JSM A44A	1.504	12.4	12.4	5.64	5.64
JSM A4488A	2.379	79.6	21.6	18.1	9.8
JSM A8888	3.632	143.0	143.0	32.5	32.5

U-Profile

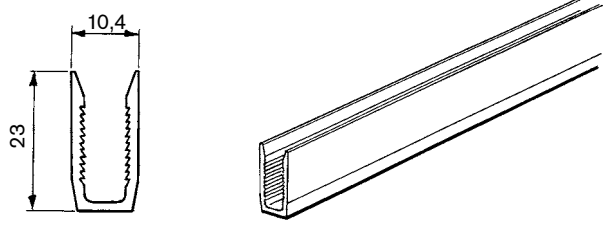
Designation	JSM A12	
Article numbers	2TLA040037R2800 (cut to size, max 2.0 m) 2TLA040037R2700 (L=1076) 2TLA040037R4600 (L=1476) 2TLA040037R4700 (L=2000)	
Material	Natural anodized aluminium	
Weight	0.230 kg/m	

H-profile

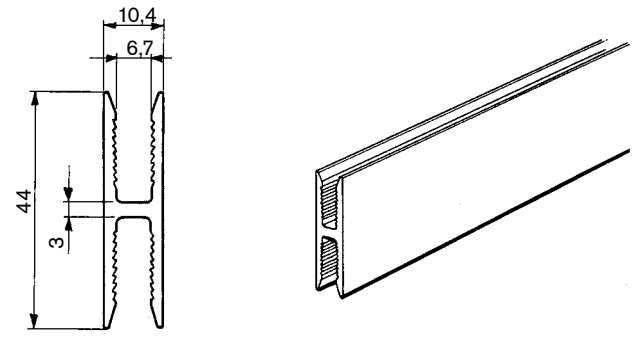
Designation	JSM A13	
Article numbers	2TLA040037R5000 (cut to size) 2TLA040037R5100 (L=1076) 2TLA040037R5200 (L=1476) 2TLA040037R5300 (L=2020)	
Material	Natural anodized aluminium	
Weight	0.452 kg/m	

Guiding Rails

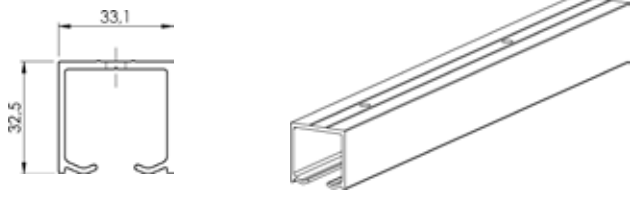
Designation	JSM A3130C	
Article number	2TLA040037R9900 (cut to size)	
Material	Natural anodized aluminium	
Holes	C/c = 240 mm, ø = 5.6 mm	
Standard Length	6.1 m (max)	
Weight	0.578 kg/m	

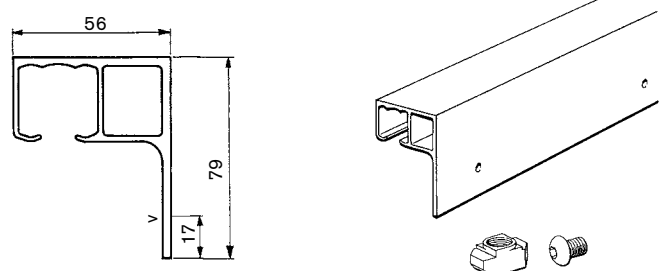
Designation	JSM A56	
Article number	2TLA040037R4900 (Cut to size incl. screws) 2TLA040037R0800 (L=2000, incl.screws) 2TLA040037R4800 (L=6000, incl.screws)	
Delivered with	Screw JSM S8E Nut JSM M8B	
Material	Natural anodized aluminium	
Holes	C/c = 450 mm, ø = 8.5 mm	
Standard Length	2.0; 6.0 m	
Weight	1.585 kg/m	

Cable Ducting

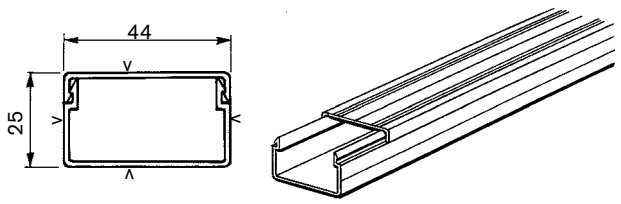
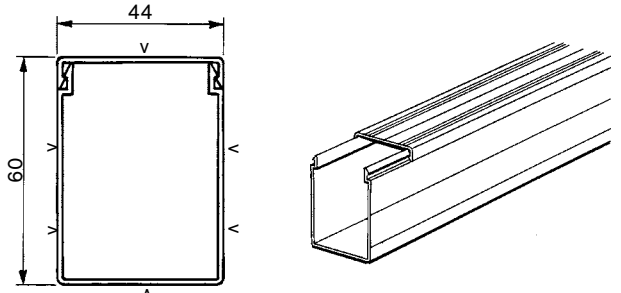
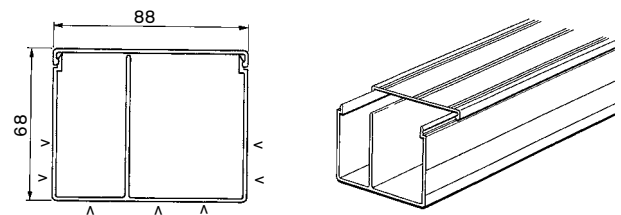
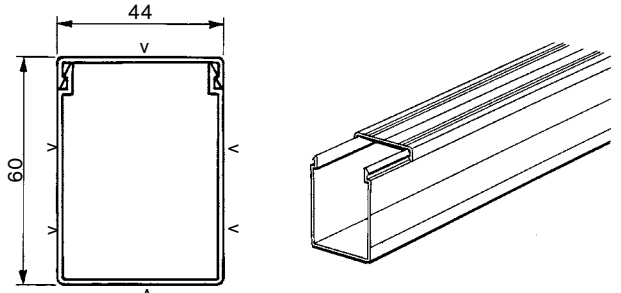
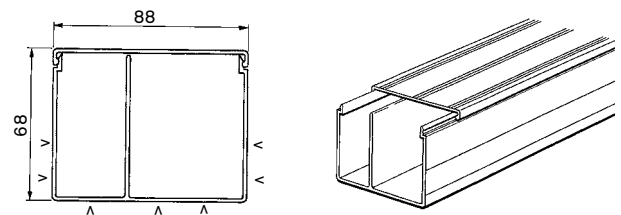
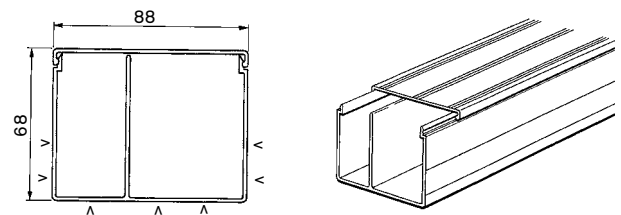
Designation	JSM A25_	
Article numbers	2TLA040037R1300 (JSM A25A) 2TLA040037R1400 (JSM A25B)	
Material	Natural anodized aluminium	
Dimensions	44 x 25 mm	
Standard Length	2.0 m	
JSM A25A	with holes C/c= 500 mm ϕ = 5 mm	
JSM A25B	without holes	
Order Unit	10 pcs/box	
Weight	0.545 kg/m JSMA25A 0.567 kg/m JSMA25B	
Designation	JSM A60_	
Article numbers	2TLA040037R1500 (JSM A60A) 2TLA040037R1600 (JSM A60B)	
Material	Natural anodized aluminium	
Dimensions	44 x 60 mm	
Standard Length	2.0 m	
JSM A60A	with holes C/c = 500 mm ϕ = 5 mm	
JSM A60B	without holes	
Order Unit	10 pcs/box	
Weight	0.923 kg/m JSMA60A 0.950 kg/m JSMA60B	
Designation	JSM A88	
Article number	2TLA040037R3300	
Material	Natural anodized aluminium	
Dimensions	88x68 mm	
Standard Length	2.0 m	
Weight	1.844 kg/m	

Cable tie

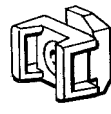
Designation	JSM X1	
Article number	2TLA040033R4300	
Pre-assembled with	Screws and Nuts	
Order Unit	10 pcs/box	
Material	Nylon 6/6 black	

Profiles for installation of sound absorbing panels

Profile for 25 mm sound absorbing panel, JSM YLA25A_

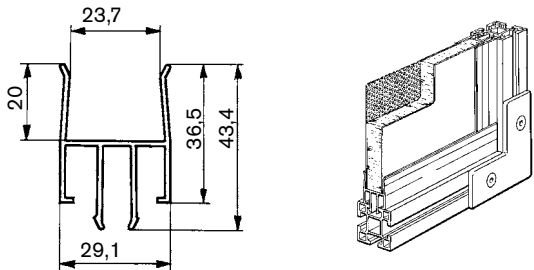
Designation	JSM AS1	
Article numbers	2TLA040037R9500 (cut to size) 2TLA040037R0900 (L=2000)	
Material	Natural anodized aluminium	
Dimensions	29 x 43 mm	
Weight	0.545 kg/m	

Profile for 50 mm sound absorbing panel, JSM YLA50A

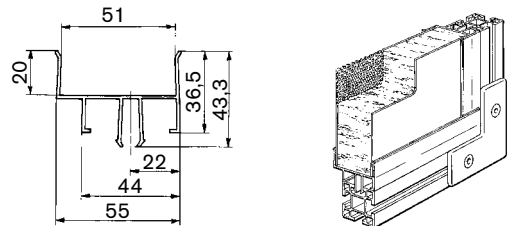
Designation	JSM AS3	
Article numbers	2TLA042021R8000 (cut to size) 2TLA042021R8100 (L=6000)	
Material	Natural anodized aluminium	
Dimensions	43 x 56	
Weight	0.694 kg/m	

Profile for double 5mm Polycarbonate panel, JSM YPC5_

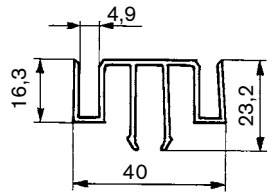
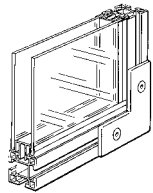
Designation	JSM AS2	 
Article numbers	2TLA040037R9600 (cut to length) 2TLA040037R1000 (L=2000)	
Material	Natural anodized aluminium	
Dimensions	40 x 23 mm	
Weight	0.510 kg/m	

Fittings

ABB Jokab Safety's fencing system is put together with various types of fitting. Uprights are anchored to the floor with floor angle fittings. With a small angle fitting it is possible to hang an electrical enclosure and strengthen the corners of free-standing walls. Corners and joints are constructed with the aid of T, L and I fittings. If angles different to 90° between the fence sections are required, a JSM D1C angle fitting can be used. This hinge has a distance between centres of 45 mm, which means that the gap between uprights will always be less than 20 mm. According to EN ISO 13857, the minimum permitted protection distance is 120 mm for a gap narrower than 20 mm.

Floor/Angle fitting

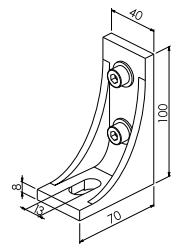
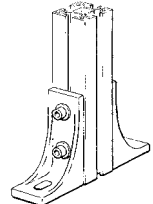
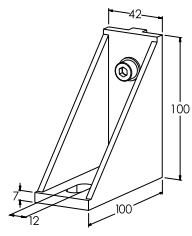
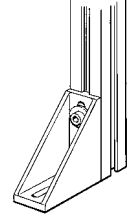
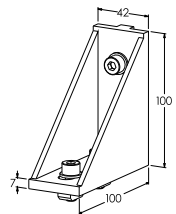
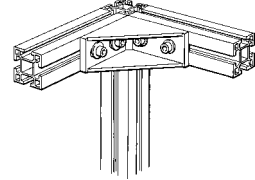



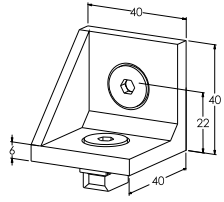
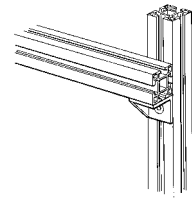

Designation	JSM 39-K	 
Article numbers	2TLA040030R1400	
Pre-assembled with	Screw JSM S8C (x 2), Washer 9 x 18 x 1.5 (x 2), Nuts JSM M8B (x 2)	
Material Order unit	Aluminium 10 pcs/box	
Designation	JSM 30B-K	 
Article number	2TLA040030R0600	
Pre-assembled with	Screw JSM S8C (x 2), Washer 9 x 18 1.5 (x 2) Nut JSM M8B (x2)	
Material Order Unit	Aluminium 10 pcs/box	
Designation	JSM 30B-K1	 
Article numbers	2TLA040030R1100	
Pre-assembled with	Screws JSM S8C (x 4), Washers 9 x 18 x 1.5 (x 4) Nuts JSM M8B (x 4), Washers JSM B8B (x 2)	
Material Order unit	Aluminium 10 pcs/box	

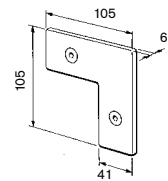
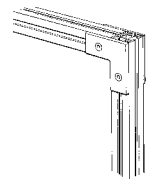
Small Angle fitting, e.g. Electrical cabinet fitting

Designation	JSM 31B-K , Two counter sunk holes JSM 31A1-K, One counter sunk hole	 
Article number	2TLA040030R1300 (JSM 31B-K) 2TLA040030R0400 (JSM 31A1-K)	
Pre-assembled with	Screw JSM M8C, Nut JSM M8B	
Material	Aluminium	
Order unit	10 pcs/box	

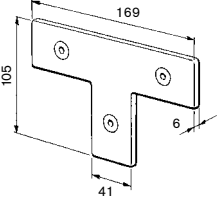
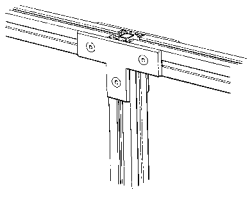
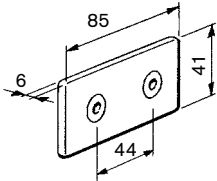
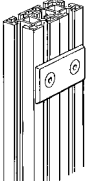
L-bracket

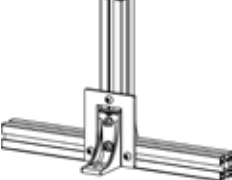
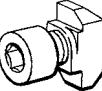
Designation	JSM 32B-K	 
Article number	2TLA040030R0700	
Pre-assembled with	Screw JSM S8A, Nut JSM M8B	
Material	Aluminium	
Order Unit	10 pcs/box	

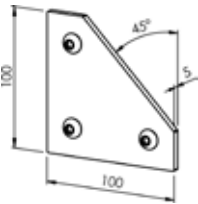
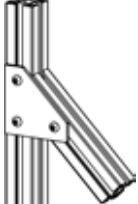
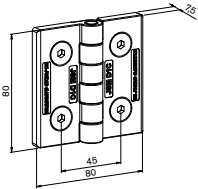
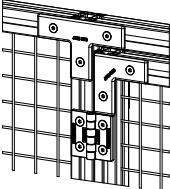
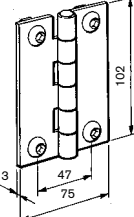
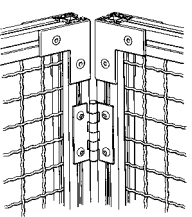
Designation	JSM 42			
Article number	2TLA042020R3200			
Pre-assembled with	Screw K6S M8x16 Steel, zinc-plated (2TLJ041017R0100) Nut JSM M8B (2TLA040035R0600)			
Material	Aluminium			
Order Unit	1 pcs			
T-bracket				
Designation	JSM 33B-K			
Article number	2TLA040030R0800			
Pre-assembled with	Screw JSM S8A, Nut JSM M8B			
Material	Aluminium			
Order Unit	10 pcs/box			
I-bracket				
Designation	JSM 34B-K			
Article number	2TLA040030R1500			
Pre-assembled with	Screw JSM S8A, Nut JSM M8B			
Material	Aluminium			
Order Unit	10 pcs/box			
U-bracket				
Designation	JSM 43			
Article number	2TLA042020R3100			
Pre-assembled with	Screw K6S M8 x 16 Steel, zinc-plated (2TLJ041017R0100) Nut JSM M8B (2TLA040035R0600)			
Material	Aluminium			
Order Unit	1 pcs			
Distance screw				
Designation	JSM 37			
Article number	2TLA040033R3100			
Material	Zinc-plated steel			
Order unit	100 pcs/box			
Angle bracket				
Designation	JSM 40			
Article number	2TLA042021R5600			
Pre-assembled with	Screw K6S M8x16 Steel, zinc-plated (2TLJ041017R0100) Nut JSM M8B (2TLA040035R0600)			
Material	Steel, zinc-plated			
Order unit	1 pcs			
13	Designation	JSM D1C Hinge		
	Article number	2TLA040033R4800		
Pre-assembled with	JSM M8B, JSM B8C, JSM S8A			
Material	Polyamide, glass fibre reinforced			
Colour	Black			
Order unit	2 pcs/bag, 10 pcs/box			
Designation	JSM 35-K			
Article number	2TLA040033R1400			
Pre-assembled with	Screw JSM S6A, Nut JSM M6B			
Material	Zinc-plated steel			
Hole	C/c = 47 mm			
Order unit	2 pcs/box			
	NOTE! The JSM 35-K must only be used for making fence angles.			

Door components

To mount conventional doors a hinge is available which permits an opening angle of 180°. For mounting a sliding door, guide rails and suspension wheels are utilised. Other sliding elements make it possible to build different types of hatches. Guide rollers, for wide and heavy doors, door closers, fittings for sensors/switches etc are also available.

Conventional Door

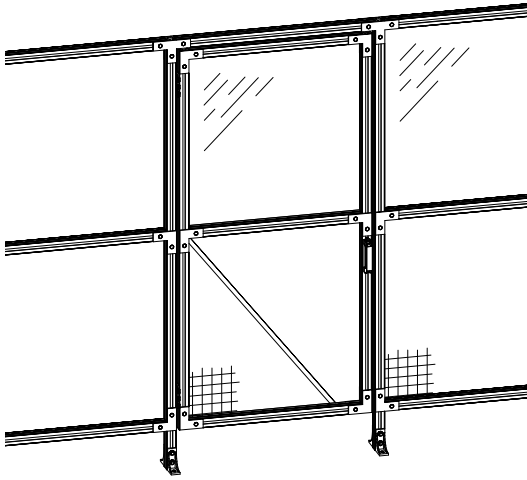

Sliding Door

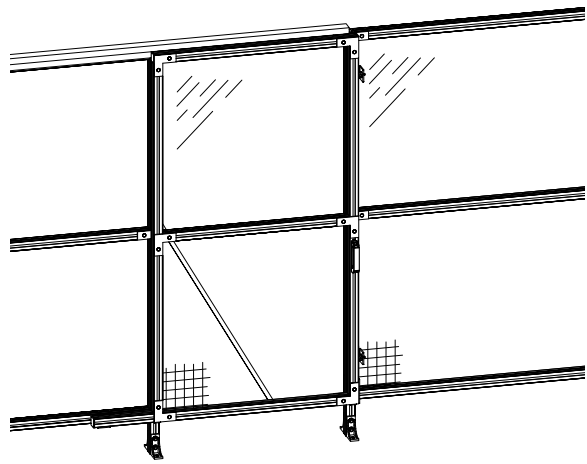

Hatch

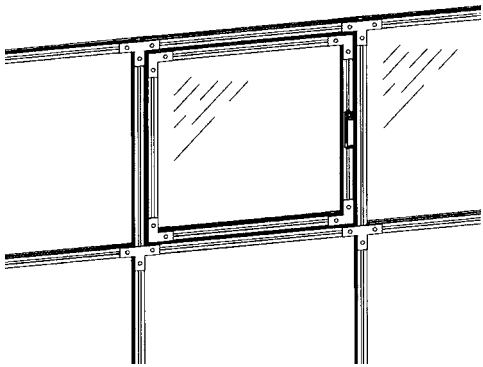

Double Hatch

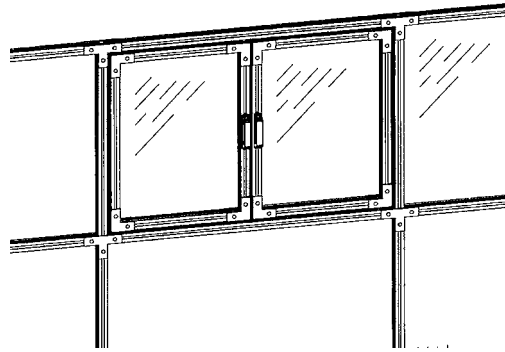

Folding Hatch

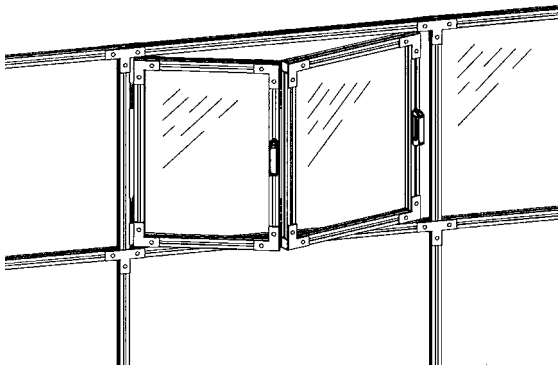

Sliding Hatch

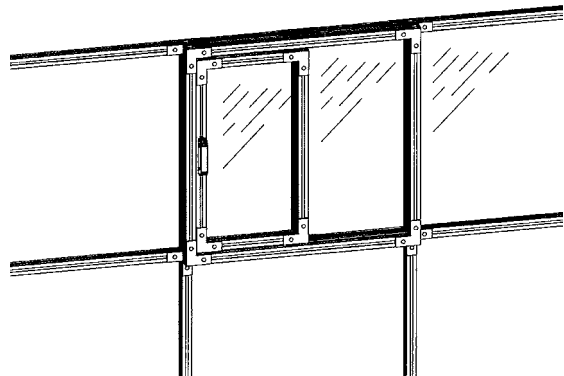

Hinge kit

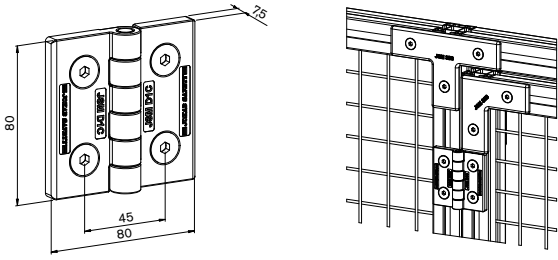
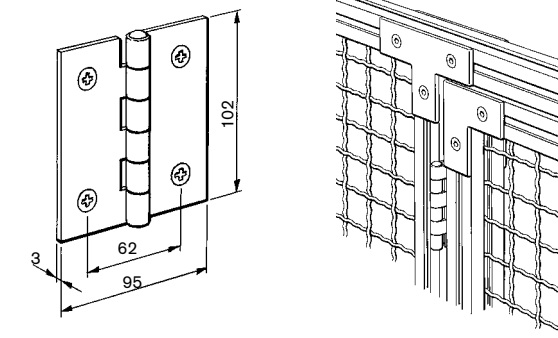
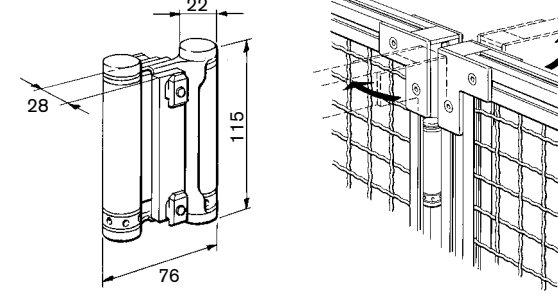
<p>Designation Article number Pre-assembled with Material Colour Order unit</p>	<p>JSM D1C Hinge 2TLA040033R4800 JSM M8B, JSM B8C, JSM S8A Polyamide, glass fibre reinforced Black 2 pcs/bag, 10pcs/box</p>	
<p>Designation Article number Pre-assembled with Material Fixing Holes Order Unit</p> <p>NOTE! JSM D1A must not be used as a fencing angle fitting because its gap can exceed 20 mm.</p>	<p>JSM D1A Hinge 2TLA040033R1500 Screw JSM S6A, Nut JSM M6B Zinc-plated steel C/c = 62 mm 2 pcs/box</p>	
<p>Designation Article numbers Material Pre-assembled with</p> <p>NOTE! The door gap will be 28 mm when installed.</p>	<p>JSM D1B Spring hinge 2TLA042020R4700 Zinc-plated steel Spacer plate, screws and nuts</p>	

Handle

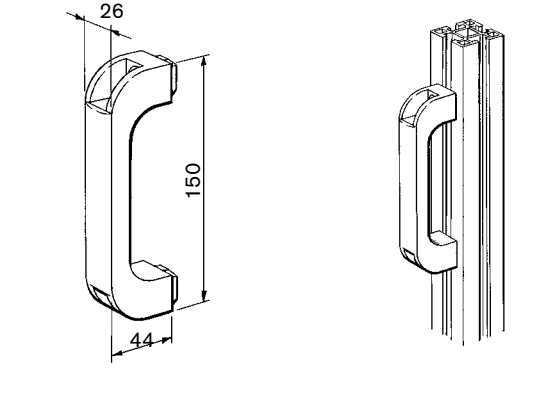
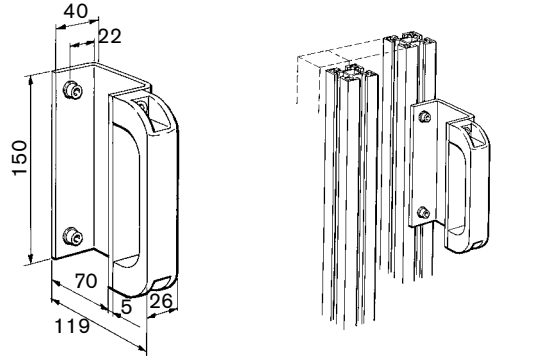
<p>Designation Article number Pre-assembled with Material</p>	<p>JSM D2 Handle 2TLA040033R0100 Screw JSM S8D, Nut JSM M8B Thermoplastic, black</p>	
<p>Designation Article number Material Pre-assembled with</p> <p>Suitable for sliding door on the inside of the fence.</p>	<p>JSM D18 Handle 2TLA042020R5000 Handle: Thermoplastic, black Fittings: Aluminum Screws and Nuts</p>	

Door closer

Designation JSM D3 (conventional door)
 Article number 2TLA040033R0200
 Pre-assembled with Screws and Nuts
 Material Door closer: Steel
 Bracket: Aluminium

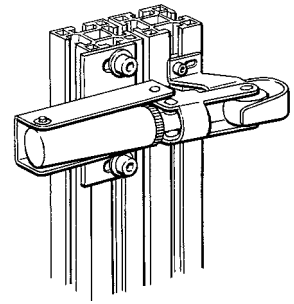
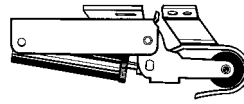

Designation JSM D19 (sliding door)
 Article number 2TLA042020R5600
 Material Zinc-plated steel
 Pre-assembled with Screws and Nuts

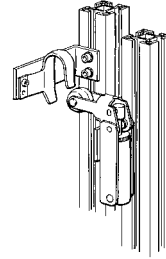

Gas spring

Designation JSM D22 Gas spring with fittings
 Article number 2TLA042024R1000
 Stroke (SL) 300 mm
 Pre-assembled with Screws and Nuts
 Material Steel

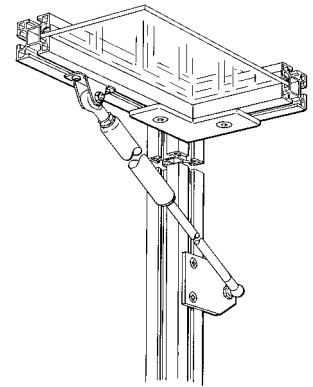
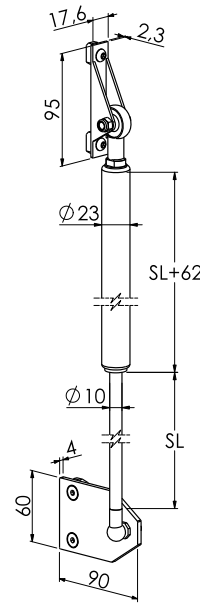

Designation JSM D22A Gas spring with fittings
 Article number 2TLA042024R1100
 Stroke (SL) 350 mm
 Pre-assembled with Screws and Nuts
 Material Steel
 Fittings included Bracket with ballcup (2TLA042021R2700)
 U-bracket with ball joint (2TLA042021R2800)

NOTE! Specify required force (100-1200N) when ordering.

Bracket for padlock

Designation JSM D17 Bracket for Padlock
 Article number 2TLA040020R2200
 Pre-assembled with Screws and Nuts
 Material Zinc-plated steel

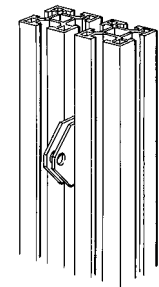
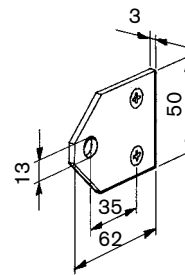

NOTE! Two pieces are required for one complete unit.

Ball Catch

<p>Designation Article number Pre-assembled with Material</p>	<p>JSM D11B (conventional door) 2TLA040033R4100 Screws and Nuts Brackets: Aluminium Ball Catch: Nickel-plated brass</p>		
<p>Designation Article number Pre-assembled with Material</p>	<p>JSM D11C (sliding door) 2TLA040033R4200 Screws and Nuts Aluminium Brackets: Aluminium Ball catch: Nickel-plated brass</p>		
<p>Designation Article number Pre-assembled with Material</p>	<p>JSM D11D (folding door) 2TLA042020R5200 Screws and Nuts Aluminium Brackets: Aluminium Ball catch: Nickel-plated brass</p>		

Upper Door bolt

<p>Designation Article number Pre-assembled with Material</p>	<p>JSM D10A 2TLA040033R2100 Screws and Nuts Rod: Stainless steel Brackets: Zinc-plated steel</p>		
---	--	--	--

Lower Door bolt

Designation JSM D10
 Article number 2TLA040033R2000
 Pre-assembled with Screws and Nuts
 Material Rod: Stainless steel
 Brackets: Zinc-plated steel

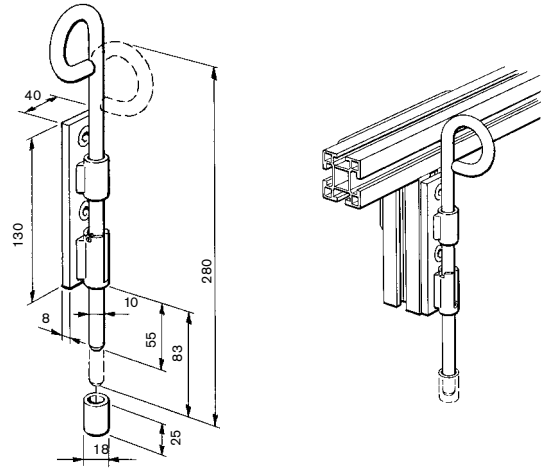

Lower Door bolt

Designation JSM D10B
 Article number 2TLA040033R3800
 Pre-assembled with Screws and Nuts
 Material Rod: Stainless steel
 Brackets: Zinc-plated steel

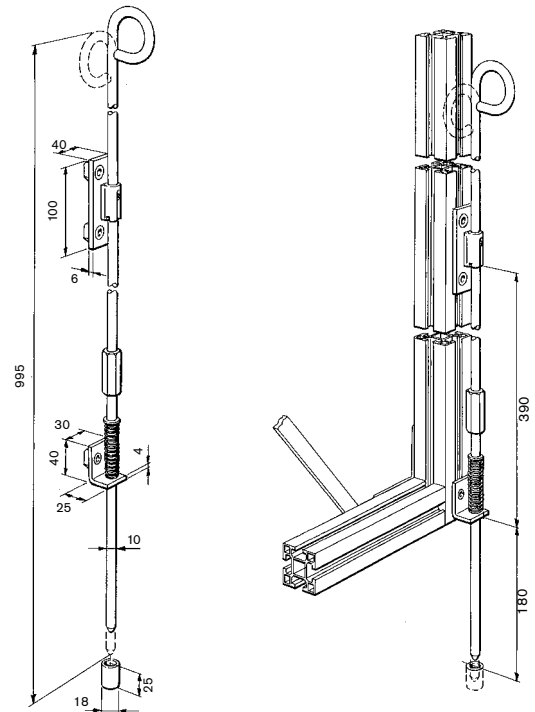

Cam lock

Designation JSM D15
 Article number 2TLA040033R3900
 Pre-assembled with Screws and Nuts
 Material Lock unit: Polyamide, black
 Brackets: Aluminium

NOTE! Delivered without key.

Key to cam lock

Designation JSM D16
 Article number 2TLA040033R4400
 Material Zinc, black

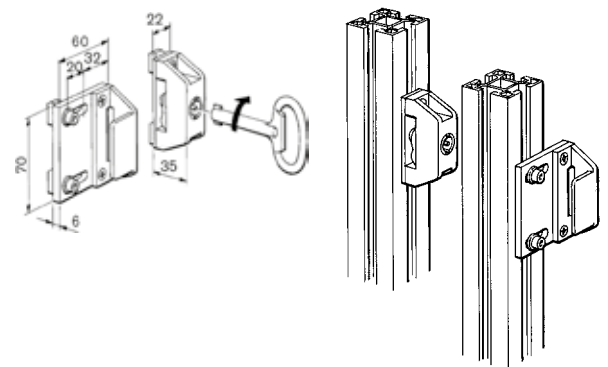

Sliding bolt for Eden

Designation
 Article numbers
 Material

 Note! Supplied without Eden
 For installation on hinged doors

JSM D20 (for hinged door)
 2TLA020302R1000
 Steel, painted yellow

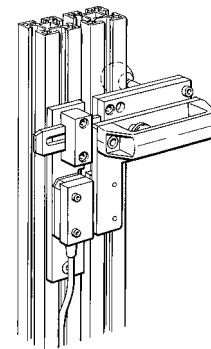
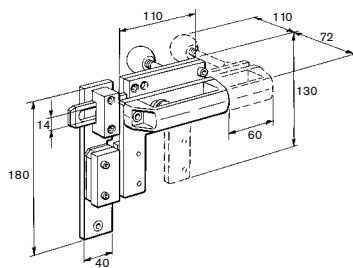

Door stop

Designation
 Article number
 Pre-assembled with
 Material

JSM D13A
 2TLA040033R2600
 Screws and Nuts
 Natural anodized aluminium

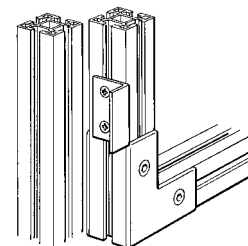
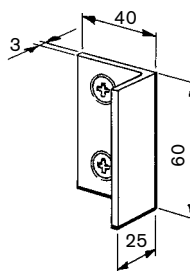

Designation
 Article number
 Pre-assembled with
 Material

JSM D13
 2TLA040033R2500
 Screws, Nuts and vibration damper
 Zinc-plated steel

NOTE! For mounting on vertical profiles.

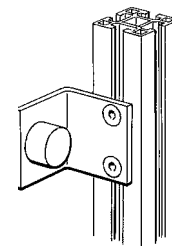
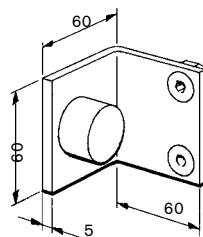



Designation
 Article number
 Pre-assembled with
 Material

JSM D13B
 2TLA040033R2700
 Screws, Nuts and vibration damper
 Zinc-plated steel

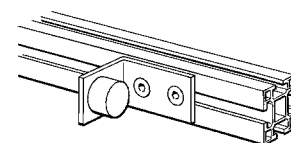
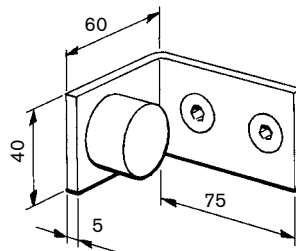
NOTE! For mounting on horizontal profiles.

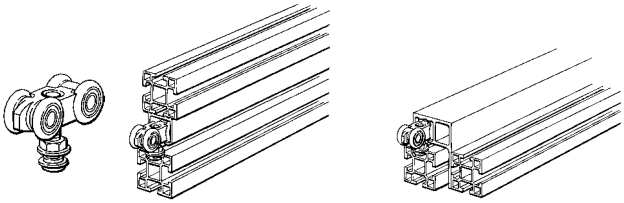
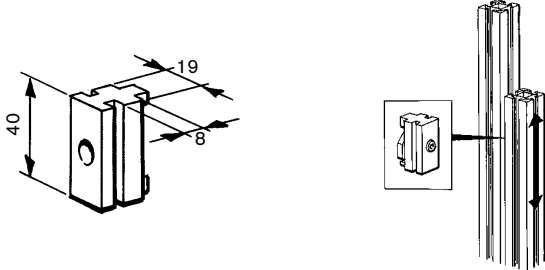
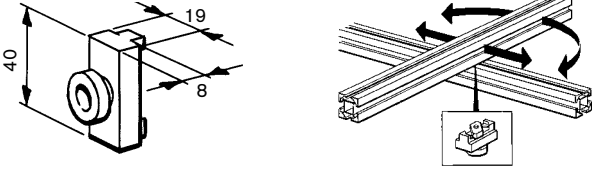
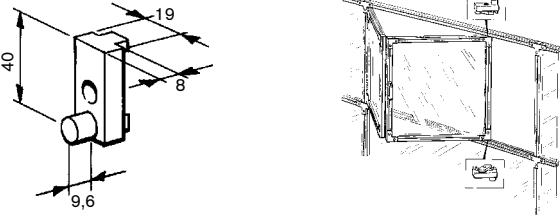

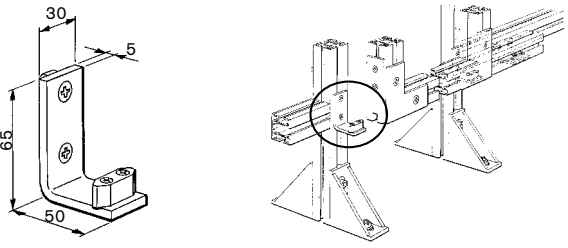
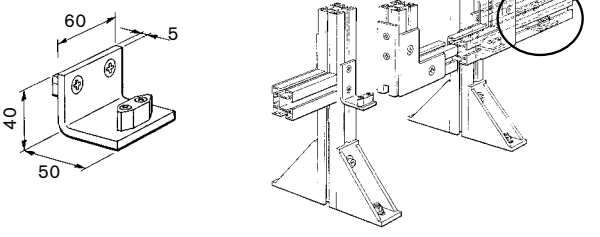
Suspension wheels		
Designation Article number For aluminium guiding rails JSM A3130C and JSM A56	JSM D5 2TLA040033R0400	
Sliding elements		
Sliding element, (rectangular) Designation Article number Pre-assembled with Material	JSM D6 2TLA040033R0500 Screw and Nut Polyamid, white	
Sliding element, (round) Designation Article number Pre-assembled with Material	JSM D7 2TLA040033R0600 Screw and Nut Polyamid, white	
Sliding element, (guide) Designation Article number Pre-assembled with Material	JSM D8 2TLA040033R0700 Screw and Nut Polyamid, white	
Sliding element, (guide) Designation Article number Pre-assembled with Material	JSM D26 2TLA042020R3700 Screw and Nut Robalon, black	
Guide Components for Sliding Door		
Designation Article number Pre-assembled with Material NOTE! For mounting on vertical profiles.	JSM D12 2TLA040033R2200 Screws and Nuts Aluminium and PA6-6	
Designation Article number Pre-assembled with Material NOTE! For mounting on horizontal profiles.	JSM D12A (Bracket) 2TLA040033R2300 Screws and Nuts Aluminium and PA6-6	

Designation	JSM D12B	
Article number	2TLA040033R2400	
Pre-assembled with	Screws and Nuts	
Material	Aluminium	

Guide roller

Swivel castor with total lock		
Designation	JSM D9-K	
Pre-assembled with angle bracket		
Article number	2TLA040033R1100	
Wheel diameter	75 mm	
Max. load	60 kg	

Fixed castor		
Designation	JSM D9A-K	
Article number	2TLA040033R1300	
Pre-assembled with angle bracket		
Wheel diameter	75 mm	
Max. load	70 kg	

Diagonal bar for door

Designation	JSM D14	
Article number	2TLA040033R2800	
Length	1160 mm	
Pre-assembled with	Screws and Nuts	
Material	Natural anodized aluminium	
Designation	JSM D14A	
Article numbers	2TLA042021R7300	
Length	400 mm	
Pre-assembled with	Screws and Nuts	
Material	Natural anodized aluminium	

Fittings for switches

Fittings for Eden

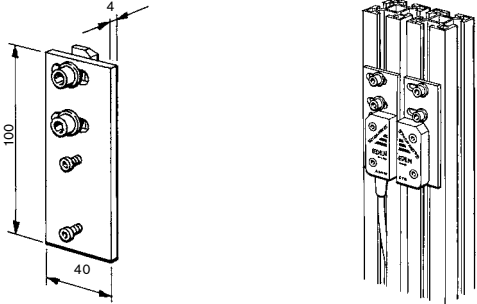
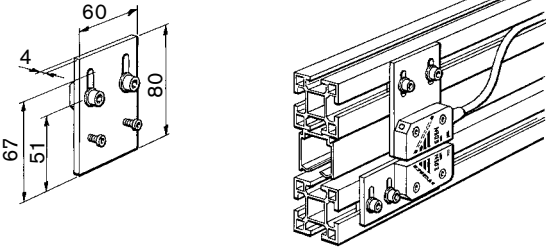
<p>Fitting for conventional- and sliding door.</p> <p>Designation Article number Pre-assembled with Material</p> <p>NOTE! Two fittings are needed for a complete Eden.</p>	<p>JSM D4H 2TLA040033R3600 Screws and Nuts Aluminium</p>	
<p>Fitting for sliding door flush with fence</p> <p>Designation Article number Pre-assembled with Material</p> <p>NOTE! One JSM D4H and one JSM D4J are needed for a complete unit.</p>	<p>JSM D4J 2TLA042020R4000 Screws and Nuts Aluminium</p>	

Fittings for JSNY5 Interlock Switches

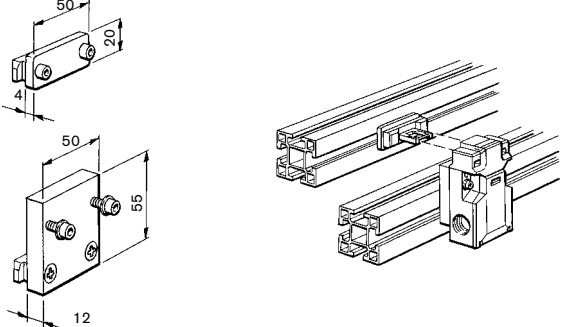
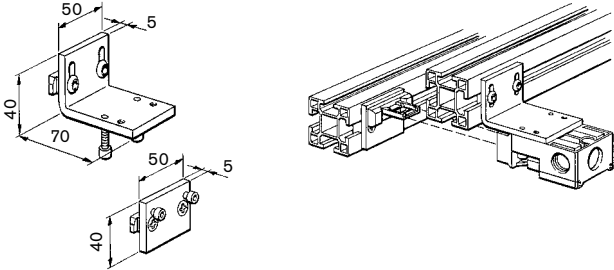
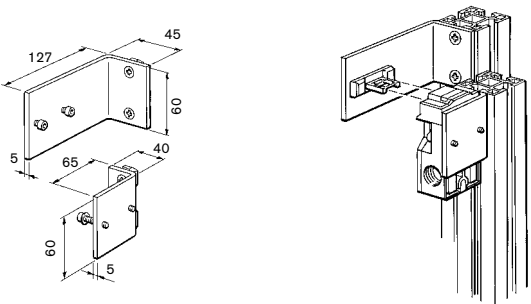
<p>Fitting for conventional door/hatch</p> <p>Designation Article number Pre-assembled with Material</p>	<p>JSM D4A 2TLA040033R0900 Screws and Nuts Zinc-plated steel</p>	
<p>Fitting for conventional door/hatch</p> <p>Designation Article number Pre-assembled with Material</p>	<p>JSM D4AA 2TLA040033R3400 Screws and Nuts Zinc-plated steel</p>	
<p>Fitting for sliding door</p> <p>Designation Article number Pre-assembled with Material</p>	<p>JSM D4B 2TLA040033R1000 Screws and Nuts Zinc-plated steel</p>	

Fittings for JSNY7 Switches

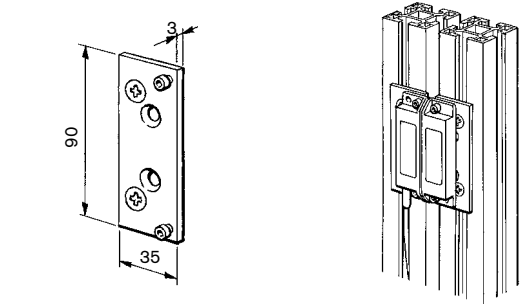
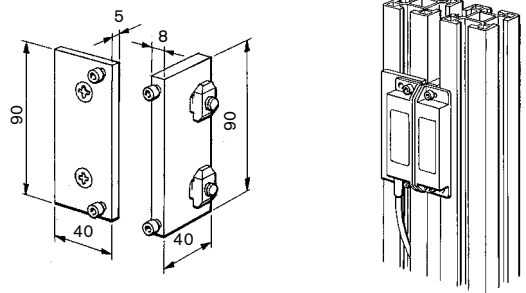
<p>Fitting for conventional door/hatch</p> <p>Designation Article number Pre-assembled with Material</p> <p>NOTE! Two fittings are needed for a complete JSNY7.</p>	<p>JSM D4E 2TLA040033R1800 Screws and Nuts Aluminium</p>	
<p>Fitting for sliding door</p> <p>Designation Article number Pre-assembled with Material</p>	<p>JSM D4G 2TLA040033R3300 Screws and Nuts Aluminium</p>	

Fittings for JSNY8/9 Switches

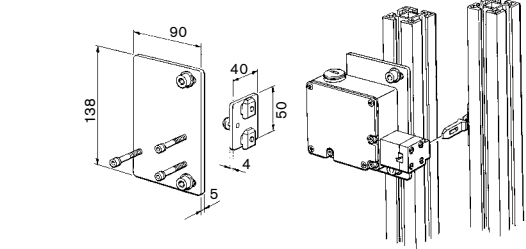
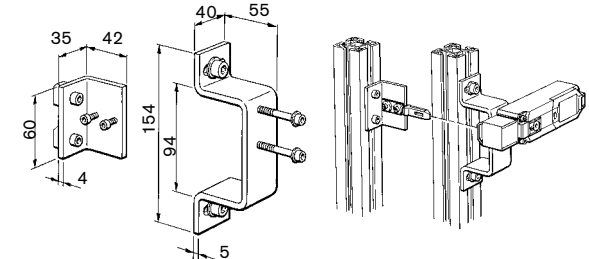
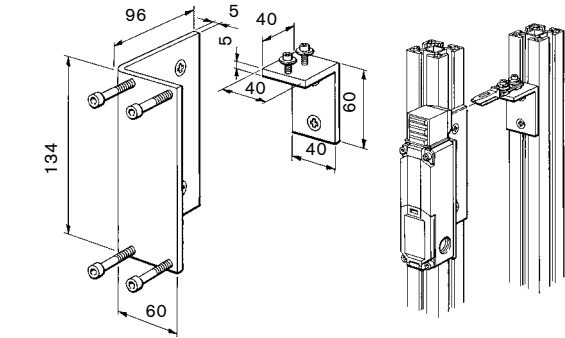
<p>Fitting for JSNY8, sliding door</p> <p>Designation Article numbers Pre-assembled with Material</p>	<p>JSM D4D 2TLA040033R1700 Screws and Nuts Zinc-plated steel</p>	
<p>Fitting for JSNY8/9, conventional door/hatch</p> <p>Designation Article number Pre-assembled with Material</p>	<p>JSM D4C 2TLA040033R1600 Screws and Nuts Zinc-plated steel</p>	
<p>Fitting for JSNY9, sliding door</p> <p>Designation Article number Pre-assembled with Material</p>	<p>JSM D4F 2TLA040033R3000 Screws and Nuts Zinc-plated steel</p>	

Terminal caps and strips

Terminal caps are available to cover profile ends, thus eliminating sharp edges. Strips are also available, both narrow and wide, to cover the slot of the fencing profile.

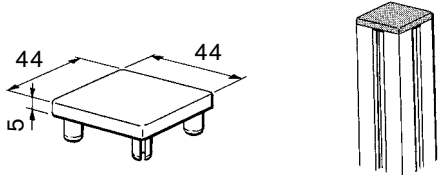
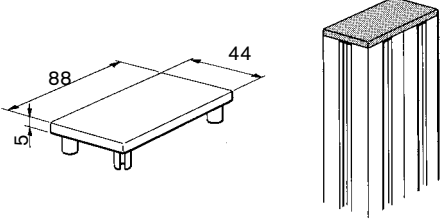
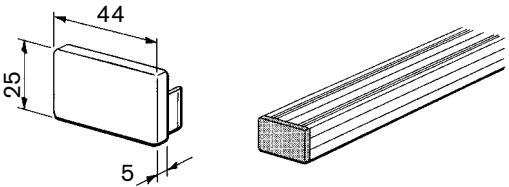
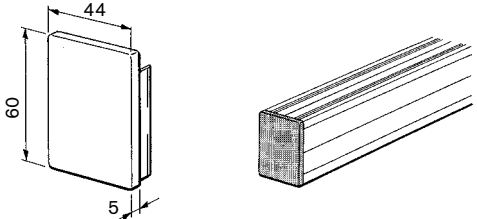
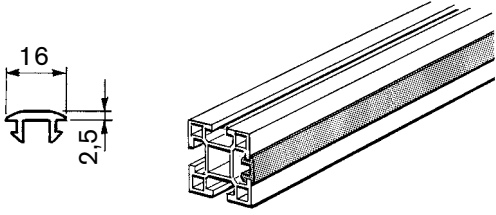
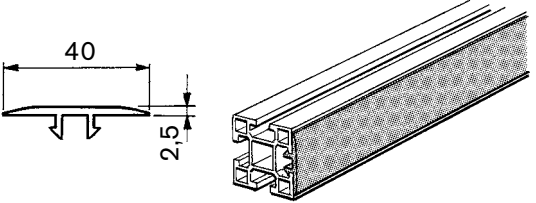
Terminal Caps		
<p>Terminal Cap for JSM A44A</p> <p>Designation</p> <p>Article numbers</p> <p>Material</p> <p>Dimensions</p>	<p>JSM L1A (yellow)</p> <p>JSM L1B (grey)</p> <p>2TLA040034R0000 (JSM L1A)</p> <p>2TLA040034R0300 (JSM L1B)</p> <p>Polyamide</p> <p>44x44 mm</p>	
<p>Terminal Cap for JSM A4488A</p> <p>Designation</p> <p>Article numbers</p> <p>Material</p> <p>Dimensions</p>	<p>JSM L4A (yellow)</p> <p>JSM L4B (grey)</p> <p>2TLA040034R0400 (JSM L4A)</p> <p>2TLA040034R0500 (JSM L4B)</p> <p>Polyamide</p> <p>44x88 mm</p>	
<p>Terminal Cap for JSM A25</p> <p>Designation</p> <p>Article number</p> <p>Material</p> <p>Dimensions</p>	<p>JSM L2</p> <p>2TLA040034R0100</p> <p>Polyamide, grey</p> <p>44x25 mm</p>	
<p>Terminal Cap for JSM A60</p> <p>Designation</p> <p>Article number</p> <p>Material</p> <p>Dimensions</p>	<p>JSM L3</p> <p>2TLA040034R0200</p> <p>Polyamide, grey</p> <p>44x60 mm</p>	
Cover Strip		
<p>Narrow Cover Strip, for Alt. 1:</p> <p>JSM A4416, -A4426, -A44A, -A4488A and -A8888</p> <p>Alt.2: For fencing profiles with 11 mm slot</p> <p>Designation</p> <p>Article numbers</p> <p>Material</p> <p>Dimensions</p> <p>Order Unit</p> <p>NOTE! Other colours available upon request</p>	<p>JSM T3A (yellow) JSM T3B (grey)</p> <p>2TLA040037R3100 (JSM T3A)</p> <p>2TLA040037R3200 (JSM T3B)</p> <p>ABS</p> <p>16 mm</p> <p>2 m</p>	
<p>Wide Cover Strip, Alt. 1:</p> <p>JSM A4416, -A4426, -A44A, -A4488A and -A8888</p> <p>Alt.2: For fencing profiles with 11mm slot</p> <p>Designation</p> <p>Article number</p> <p>Material</p> <p>Dimensions</p> <p>Order Unit</p> <p>NOTE! Other colours available upon request</p>	<p>JSM T2A</p> <p>2TLA040037R1900</p> <p>PVC, yellow, soft material</p> <p>40 mm</p> <p>25 m/coil</p>	

Accessories

All fittings and door components are delivered pre-assembled with screws, washers and nuts.
For cable ducting the screws, S5B, and nuts, M5B, have to be ordered separately (4 pcs/2m).

Designation	Image	Article number	Description	Dimension	Material	Order Unit
JSM S5B		2TLA041039R0100	Screw to cable ducting	M5x12	Zinc Plated Steel	100 pcs/box
JSM S6A		2TLA041039R0200	Screw for hinge cross-slotted Z (pozidrive)	M6x12	Zinc Plated Steel	100 pcs/box
JSM S8A		2TLA041019R0000	Fixing screw countersunk.	M8x16	Zinc Plated, Dacrolit	100 pcs/box
JSM S8C		2TLA041014R0200	Fixing screw for floor fitting and small angle	M8x20	Zinc Plated Steel	100 pcs/box
JSM S8D		2TLA041014R0100	Fixing screw	M8x16	Zinc Plated Steel	100 pcs/box
JSM S8E		2TLA041019R0100	Fixing screw for Guide rail JSM A56	M8x12	Zinc Plated Steel	100 pcs/box
JSM M4B		2TLA040035R0700	Locking nut	M4	Zinc Plated Steel	100 pcs/box
JSM M5B		2TLA040035R0400	Locking nut	M5	Zinc Plated Steel	100 pcs/box
JSM M6B		2TLA040035R0500	Locking nut	M6	Zinc Plated Steel	100 pcs/box
JSM M8B		2TLA040035R0600	Locking nut	M8	Zinc Plated Steel	100 pcs/box
JSM M10A		2TLA041069R0000	M10 Thread insert for JSM A44A	M10x21, Ø18.5/25	Steel, zinc-plated	1 pcs
JSM X1		2TLA040033R4300	Cable tie	2.5–7.8 mm	Nylon black UV-resistant	10 pcs/box
JSM X2		2TLA041900R4300	Expansion-shell bolt	M10x68	Zinc Plated Steel	50 pcs/box
JSM X3		2TLA041910R0000	Window cleaning fluid (Antistatic) for polycarbonate sheets. Actuator head 0.5 L.			per can
JSM X4		2TLA041911R0100	Mesh clipping tool	L=300		each
JSM X5A		2TLA041810R0200	ABB Safety Products sign	220x40x1.5mm	Aluminium, Natural anodized	1 pcs
JSM X5B		2TLA041810R0300	ABB Safety Products sign, pre-assembled with screws	220x40x1.5mm	Aluminium, Natural anodized	1 pcs
JSM B4C		2TLA040035R5000	Centring washer steel	Ø4.2	Zinc Plated Steel	100 pcs/box
JSM B5C		2TLA040035R5100	Centring washer steel	Ø5.2	Zinc Plated Steel	100 pcs/box
JSM B6C		2TLA040035R5200	Centring washer steel	Ø6.2	Zinc Plated Steel	100 pcs/box
JSM B8C		2TLA040035R5300	Centring washer steel	Ø8.2	Zinc Plated Steel	100 pcs/box

Infill materials

The choice of net and surfaces depends, among other things, on the protection distance. In the case of netting, a minimum distance of 200 mm (for anyone aged 14 or older) with a mesh size of 40x40 mm in accordance with EN ISO 13857. For closer protection distances and for noise reduction, solid panels are used. Panels are available in different materials. For protection of welding cells, polycarbonate welding transparencies are used.

Welded mesh		Designation	JSM YN40W_/WE_		
		Square opening	40 x 40 mm		
		Thread	ø 3.5 mm		
Article number	Designation	Material	Dimensions	Type	
2TLA040040R1300	JSM YN40W1	Steel, black RAL 9005 powder coated	2020 x 864 mm	Welded	
2TLA040040R1400	JSM YN40W2	Steel, black RAL 9005 powder coated	1074 x 1816 mm	Welded	
2TLA040040R1500	JSM YN40W3	Steel, black RAL 9005 powder coated	1074 x 2016 mm	Welded	
2TLA040040R2000	JSM YN40W4	Steel, black RAL 9005 powder coated	1474 x 2016 mm	Welded	
2TLA040040R2100	JSM YN40W5	Steel, black RAL 9005 powder coated	1474 x 1816 mm	Welded	
2TLA040040R2600	JSM YN40W6	Steel, black RAL 9005 powder coated	2020 x 754 mm	Welded	
2TLA040040R2700	JSM YN40W7	Steel, black RAL 9005 powder coated	2020 x 1174 mm	Welded	
2TLA040040R1600	JSM YN40W9	Steel, black RAL 9005 powder coated	Cut to size	Welded	
2TLA040040R2800	JSM YN40W10	Steel, black RAL 9005 powder coated	1474 x 1216 mm	Welded	
2TLA040040R2900	JSM YN40W11	Steel, black RAL 9005 powder coated	1074 x 1216 mm	Welded	
2TLA040040R2500	JSM YN40WE1	Stainless steel, SS 2333	2020 x 864 mm	Welded	
2TLA040040R1800	JSM YN40WE2	Stainless steel, SS 2333	1074 x 1816 mm	Welded	
2TLA040040R1900	JSM YN40WE9	Stainless steel, SS 2333	Cut to size	Welded	

Other colours, hot-dip galvanized mesh or woven wire mesh netting supplied on request.

Net lock for welded mesh with outer wire

Designation	JSM NL2	
Article numbers	2TLA040031R0600	
Material	PA/ABS	
Colour	Grey	
Order unit	100 pcs/box	

Net lock for welded or woven mesh

Designation	JSM NL3	
Article numbers	2TLA040031R0800	
Pre-assembled with	Screw	
Material	Zinc	
Order unit	100 pcs/box	

Shockproof panelling

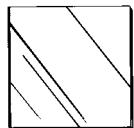

Plastic panels
name: JSM Y_
Other materials can be supplied on request.

Plastic panel name: JSM Y_

Article number	Designation	Material	Thickness	Dimensions
2TLA040039R1000	JSM YPC5A1	Polycarbonate, uncoloured	5 mm	2020 x 864
2TLA040039R1100	JSM YPC5A2	Polycarbonate, uncoloured	5 mm	2020 x 1174
2TLA040039R1200	JSM YPC5A9	Polycarbonate, uncoloured	5 mm	Cut to size
2TLA040039R2400	JSM YPC3AC9	Polycarbonate, dark tint, weld-protected	3 mm	Cut to size
2TLA040039R2500	JSM YPC3AC1	Polycarbonate, dark tint, weld-protected	3 mm	2050 x 3000
2TLA042150R0600	JSM YG6A9	Laminated glass	6.4 mm	Cut to size

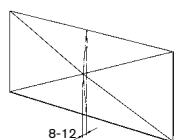

X-reinforced steel panel
Other materials are available on request.

Steel panel

Article number	Designation	Material	Thickness	Dimensions
2TLA040039R0700	JSM YGP1A9	Galvanised sheet metal	1 mm	Cut to size
2TLA040039R0900	JSM YGP2A9	Galvanised sheet metal	1.5 mm	Cut to size

Painted sheet metal can be supplied on request.

Panel fixings

Designation: JSM PL1_(for 5 mm panels)
JSM PL2_(for 4 mm panels)

Material:
JSM PL1: PVC, black
JSM PL2: PVC, black
Standard package: 50 pcs/package

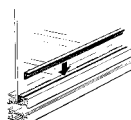
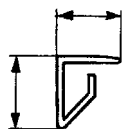

Article number	Designation	Length
2TLA040038R0100	JSM PL1A	842 mm
2TLA040038R0200	JSM PL1B	1152 mm
2TLA040038R0300	JSM PL1C	2000 mm
2TLA040038R0400	JSM PL1D	732 mm
2TLA040038R0700	JSM PL2A	842 mm
2TLA040038R0800	JSM PL2B	1152 mm
2TLA040038R0900	JSM PL2C	2000 mm
2TLA040038R1000	JSM PL2D	732 mm

Cellular rubber - To be used with e.g. 1.0 mm steel panel

Designation: JSM G2
Article numbers: 2TLA040038R0600
Material: Cellular rubber, self-adhesive
Dimension: 5 x 20 mm
Standard package: 10 m/roll

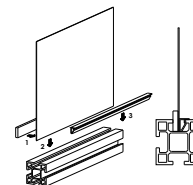
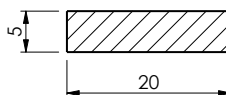

U-rubberstrip - To be used with e.g. 6.4 mm laminated glass

Designation: JSM G3
Article numbers: 2TLA041930R0600
Material: EPDM
Standard package: 50 m/roll

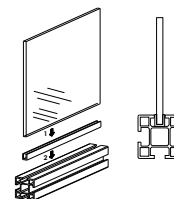
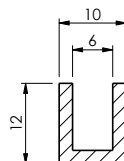

Panel lock

Designation: JSM PL3
Article numbers: 2TLA040038R1100
Pre-assembled with: Screw
Material: Zinc

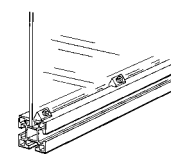

Sound absorbing

Article number	Designation	Material	Thickness	Dimensions	Weight (kg/m ²)
2TLA040037R1100	JSM YLA25A9	Core Rock wool	25 mm	Cut to size	13.8
2TLA040039R2600	JSM YLA25A1	Solid surface PVC coated steel plate, White	25 mm	1963 x 1200	13.8
2TLA042150R2300	JSM YLA50A9	Perforated surface Hot dipped galvanized Steel sheet	50 mm	Cut to size	21.0

Cut to size – max dimension 2000 x 1200

NOTE! Use mounting profile JSM AS1 for JSM YLA25A_ Use mounting profile JSM AS3 for JSM YLA50A_

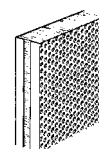

Safety Roller Door



Approvals:

CE

Application:

- Allowing access to risk areas
- Protection from ejected particles, e.g chips and welding splash

Features:

- Highest safety level according to EN ISO 13849-1
- Prevents unintentional start
- Withstands harsh environments
- Quick operation
- High reliability
- Noise absorbing

Roller door for short safety distances and narrow spaces

Safety Roller Doors make it possible to have a short safety distance to the machine. The noise absorbing roller door is compact and it can therefore be placed in narrow spaces. It is easy and quick to access the machine or gain access for servicing with the Safety Roller Door.

It demands a minimum of maintenance and offers reliable operation. To be able to start the machine/plant the door has to be completely closed. The closed position is monitored by the Eden non-contact sensor from ABB Jokab Safety. As soon as the door begins to open the Eden sends a signal to the machine/plant via the Pluto Safety-PLC from ABB Jokab Safety. The roller door fulfills safety category 4 together with Eden and Pluto.

Protects against welding splash

The roller door protects against ejected particles, such as chips and welding splash. The roller door fabric is also resistant towards a great number of chemicals, which permits it to be installed in harsh environments.

Simple assembly

The Safety Roller Door is simple to assemble because it consists of few components and it is supplied partly pre-assembled. It can be integrated into the Quick-Guard fencing system from ABB Jokab Safety as well as in other types of fencing systems. It can also be installed on the machine or other permanent construction.

Customized roller door

This door design is easy to customize. The largest possible opening width is 4000 mm and the largest possible opening height is 3500 mm. The maximum size of the door fabric is 10 m². If a larger door fabric is desired, contact ABB Jokab Safety. The door is supplied as standard with a light-grey door fabric. Other colours can also be supplied. The roller door can be supplied with a viewing window in full width and at an optional height. The viewing window can also be made in a special material that protects against welding splash.

Function

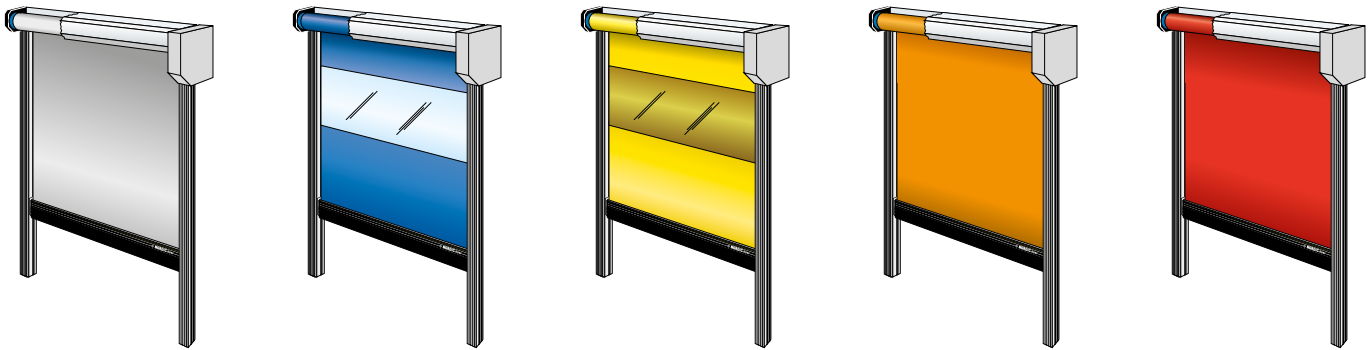

Highest protection in accordance with EN ISO 13849-1

The monitoring of the door's position by two Eden sensors together with a Pluto monitoring unit fulfills Cat. 4/PL e in accordance with EN ISO 13849-1. These units are certified by TÜV.

Functions

The door protects against access to moving parts in the machine/plant. The production process can begin when the door is fully closed. The closed position is monitored by an Eden sensor on both sides of the door. Because the door is monitored by Eden sensors at both sides of the door it is impossible to lift one side of the door and reach into the risk area without the machine/plant stopping. When the door has moved a maximum of 10 mm upwards a stop signal is sent to the protected machine/plant. The Eden sensors are monitored by a Pluto Safety-PLC which has failsafe outputs for stopping the machine/plant in the risk area and to control the door.

The door also protects from particles ejected by the production process, e.g. chips and welding splash. It has a good sound absorbing ability. Because the door operates quickly, at 0.8-1.0 m/s, the operator has a good access to the machine area. The door is equipped with a safety contact strip in the bottom preventing it from causing personal injury on any person. When the safety contact strip is affected the door is

compressed, the door movement reverses to move upwards. The opening and closing of the door can be controlled via the buttons or via the signals from the control system of the machine.

Prevents an unintentional start

When the door is located in front of the machine/plant, where the operator can enter the area with his entire body, safe interlocking of the door's downward movement is needed. This is to prevent the machine from being started from the outside when somebody is inside the roller door.

One way to solve this is to use a horizontal light curtain which covers the area which the operator can occupy within the risk area. Another solution is to place double light beams in the opening, combined with a reset facility. Yet another solution is to use time-reset. A time-reset button is placed inside the risk area and a button is placed outside the risk area. First, the button in the risk area should be pressed and thereafter (within a certain amount of time, e.g. 5 seconds) the button outside should be pressed. After this the door can be manoeuvred downwards.

Safety distances and standards

Minimum safety distance

For the roller door to be able to provide good protection it has to be installed a sufficient distance away from moving machine parts.

Useful standards

EN ISO 13857 Safety of machinery - Safety distances to prevent hazard zones being reached by upper and lower limbs.
EN ISO 13855 Safety of machinery – Positioning of safeguards with respect to the approach speeds of parts of the human body.

NOTE! The roller door has good protection against welding splash and smaller ejected particles from the production area. The roller door is not intended to act as collision protection. The installer of the roller door has the responsibility of ensuring that sufficient safety distance against moving machine parts is provided.

Technical data – Safety Roller Door

Colour	Frame - aluminium, door cloth - grey. Other colours available on request.
Ordering data	Safety Roller door + viewing window. Viewing window with weld splash protection. Daylight height & Daylight width.
Maximum size, door cloth	10 m ² . If a larger size is needed, contact ABB Jokab Safety AB.
Maximum width	4000 mm
Maximum height	3500 mm
Driving unit	Three-phase motor 200-415 VAC 50-60 Hz
Speed, roller door	0.8 – 1.0 m/s up/down
Max. number of cycles/minute	3 (during continuous operation 24 hours a day)
Door fabric material	Multi-layer polyester fabric cloth with PVC, 2 mm thick or transparent PVC. The viewing window can also be supplied with protection against welding flash light. (Removes 99% of the UV-transmission from the welding process)
Door fabric colour	Grey (RAL 7038), can be supplied with recessed window (only in full width). Other colours are available.
Material frames	Aluminum extrusion
Material upper bracket	4 mm steel painted black
Sound absorption	approx. 10 dB
Ambient temperature	0°C to +55°. When operating in temperatures below -5°C, the oil in the gear-box should be replaced with an oil suitable to withstand cold temperatures.
Safety level	Category 4/PL e, in accordance with EN ISO 13849-1
Durability towards chemicals	Ammoniac, sodium hydrate, phosphoric acid, tartaric acid, oxalic acid, hydrochloric acid, citric acid, acetic acid, oil, detergent, calcium chloride (contact ABB Jokab Safety for more specifications)
Control monitoring unit for roller door	ABB Jokab Safety's Safety-PLC, Pluto
Outputs	4 safe outputs for connection to machine/plant.
Monitoring of position of the roller door	2 Eden sensors one on each side of the door.
Contact strip	Mounted on the bottom frame of the door fabric. The door motion is reversed if the contact strip is compressed.

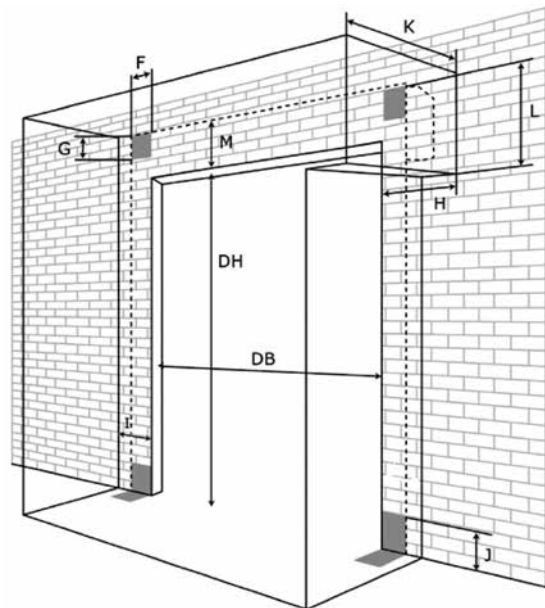
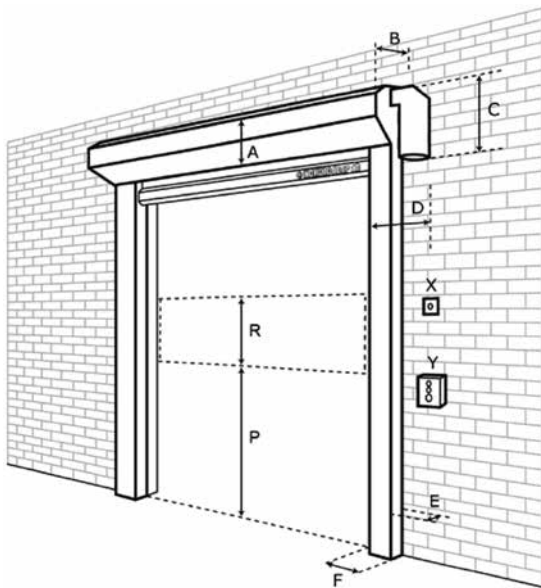

A	260	DB	
B	270	DH	
C	400	F	80
D	200	G	250
E	120	H	320
F	80	I	150
P	Optional	J	100
R	Optional	K	500
		L	500
		M	450

Notes

A series of horizontal dotted lines for writing notes.

Notes

A series of horizontal dotted lines for writing notes.

Notes

A series of horizontal dotted lines for writing notes.

Notes

A series of horizontal dotted lines for writing notes.

Notes

A series of horizontal dotted lines for writing notes.

Contact us

ABB AB
Jokab Safety
Tel. +46 21-32 50 00
www.abb.com/jokabsafety

Note: We reserve the right to make technical changes or modify the contents of this document without prior notice. With regard to purchase orders, the agreed particulars shall prevail. ABB AB, Jokab Safety does not accept any responsibility whatsoever for potential errors or possible lack of information in this document.

We reserve all rights in this document and in the subject matter and illustrations contained therein. Any reproduction, disclosure to third parties or utilization of its contents – in whole or in parts – is forbidden without prior written consent of ABB AB, Jokab Safety.

Copyright © 2013 ABB
All rights reserved

© Copyright ABB 2TLC172001C0202

X-ON Electronics

Largest Supplier of Electrical and Electronic Components

Click to view similar products for [Proximity Sensors](#) category:

Click to view products by [ABB](#) manufacturer:

Other Similar products are found below :

[01.001.5653.1](#) [70.340.1028.0](#) [70.360.2428.0](#) [70.364.4828.0](#) [70.810.1053.0](#) [72.360.1628.0](#) [73.363.6428.0](#) [9221350022](#) [980659-1](#) [QT-12](#)
[E2EX10D1NN](#) [E2E-X14MD1-G](#) [E2E-X2D1-G](#) [E2EX2ME2N](#) [E2E-X3D1-N](#) [10M](#) [E2E-X4MD1-G](#) [E2FMX1R5D12M](#) [E2K-F10MC1](#) [5M](#)
[EI1204TBOSL-6](#) [EI5515NPAP](#) [BSA-08-25-08](#) [IC08ANC15PO-K](#) [IMM2582C](#) [25.161.3253.0](#) [25.332.0653.1](#) [25.352.0653.0](#) [25.352.0753.0](#)
[25.523.3253.0](#) [9151710023](#) [922FS1.5C-A4P-Z774](#) [SC606ABV0S30](#) [SM952A126100LE](#) [A1220EUA-T](#) [F3S-A162-U](#) [CL18](#) [QT-08L](#)
[34.110.0010.0](#) [TL-C2MF1-M3-E4](#) [IA08BLF15NOM5](#) [IA08BSF15NOM5](#) [IA12ASF04DOM1](#) [IMM32188C](#) [IS2](#) [IS31SE5000-UTLS2-TR](#)
[34.110.0021.0](#) [34.110.0022.0](#) [CA150-120VACDC](#) [VM18VA3000Q](#) [XS508BSCBL2](#) [XS512BLNAM12](#)