

**5SNA 2000K452300****StakPak IGBT Module**  
**Preliminary** $V_{CE} = 4500 \text{ V}$  $I_C = 2000 \text{ A}$ 

Fails in shorted state stable for up to 1 minute\*

Low-loss, rugged SPT+ chip-set

Smooth switching SPT+ chip-set for good EMC

High tolerance to uneven mounting pressure

Explosion resistant package

**Maximum rated values <sup>1)</sup>**

Parameter	Symbol	Conditions	min	max	Unit
Collector-emitter voltage	$V_{CES}$	$V_{GE} = 0 \text{ V}, T_{vj} \geq 25 \text{ °C}$		4500	V
DC collector current	$I_C$	$T_C = 85 \text{ °C}, T_{vj} = 125 \text{ °C}$		2000	A
Peak collector current	$I_{CM}$	$t_p = 1 \text{ ms}$		4000	A
Gate-emitter voltage	$V_{GES}$		-20	20	V
Total power dissipation	$P_{tot}$	$T_C = 25 \text{ °C}, T_{vj} = 125 \text{ °C}$		20800	W
DC forward current	$I_F$			2000	A
Peak forward current	$I_{FRM}$	$t_p = 1 \text{ ms}$		4000	A
Surge current	$I_{FSM}$	$V_R = 0 \text{ V}, T_{vj} = 125 \text{ °C},$ $t_p = 10 \text{ ms}, \text{ half-sinewave}$		14000	A
IGBT short circuit SOA	$t_{psc}$	$V_{CC} = 3400 \text{ V}, V_{CEM \text{ CHIP}} \leq 4500 \text{ V}$ $V_{GE} \leq 15 \text{ V}, T_{vj} \leq 125 \text{ °C}$		10	$\mu\text{s}$
Junction temperature	$T_{vj}$		-50	150	$^{\circ}\text{C}$
Junction operating temperature	$T_{vj(op)}$		-50	125	$^{\circ}\text{C}$
Case temperature	$T_C$		-50	125	$^{\circ}\text{C}$
Storage temperature	$T_{stg}$		-50	70	$^{\circ}\text{C}$
Mounting force <sup>2)</sup>	$F_M$		60	90	kN

<sup>1)</sup> Maximum rated values indicate limits beyond which damage to the device may occur per IEC 60747<sup>2)</sup> For detailed mounting instructions refer to ABB document no. 5SYA 2037-02

\* Functionality is load profile dependent and is to be agreed upon.

**IGBT characteristic values <sup>3)</sup>**

Parameter	Symbol	Conditions	min	typ	max	Unit
Collector (-emitter) breakdown voltage	$V_{(BR)CES}$	$V_{GE} = 0 \text{ V}$ , $I_C = 10 \text{ mA}$ , $T_{vj} = 25 \text{ }^\circ\text{C}$	4500			V
Collector-emitter <sup>4)</sup> saturation voltage	$V_{CE \text{ sat}}$	$I_C = 2000 \text{ A}$ , $V_{GE} = 15 \text{ V}$	$T_{vj} = 25 \text{ }^\circ\text{C}$	2.85	3.15	V
			$T_{vj} = 125 \text{ }^\circ\text{C}$	3.65	3.95	V
Collector cut-off current	$I_{CES}$	$V_{CE} = 4500 \text{ V}$ , $V_{GE} = 0 \text{ V}$	$T_{vj} = 25 \text{ }^\circ\text{C}$		1	mA
			$T_{vj} = 125 \text{ }^\circ\text{C}$	50	100	mA
Gate leakage current	$I_{GES}$	$V_{CE} = 0 \text{ V}$ , $V_{GE} = \pm 20 \text{ V}$ , $T_{vj} = 125 \text{ }^\circ\text{C}$	-500		500	nA
Gate-emitter threshold voltage	$V_{GE(th)}$	$I_C = 320 \text{ mA}$ , $V_{CE} = V_{GE}$ , $T_{vj} = 25 \text{ }^\circ\text{C}$	5.3		7.3	V
Gate charge	$Q_G$	$I_C = 2000 \text{ A}$ , $V_{CE} = 2800 \text{ V}$ , $V_{GE} = -15 \text{ V} \dots 15 \text{ V}$		9.6		$\mu\text{C}$
Input capacitance	$C_{ies}$	$V_{CE} = 25 \text{ V}$ , $V_{GE} = 0 \text{ V}$ , $f = 1 \text{ MHz}$ , $T_{vj} = 25 \text{ }^\circ\text{C}$		186		nF
Output capacitance	$C_{oes}$			13.4		nF
Reverse transfer capacitance	$C_{res}$			3.7		nF
Internal gate resistor	$R_{Gint}$			0.16		$\Omega$
Turn-on delay time	$t_{d(on)}$	$V_{CC} = 2800 \text{ V}$ , $I_C = 2000 \text{ A}$ , $R_G = 1.8 \text{ } \Omega$ , $C_{GE} = 330 \text{ nF}$ , $V_{GE} = \pm 15 \text{ V}$ , $L_\sigma = 200 \text{ nH}$ , inductive load	$T_{vj} = 25 \text{ }^\circ\text{C}$	820		ns
			$T_{vj} = 125 \text{ }^\circ\text{C}$	690		ns
Rise time	$t_r$	$V_{CC} = 2800 \text{ V}$ , $I_C = 2000 \text{ A}$ , $R_G = 1.8 \text{ } \Omega$ , $C_{GE} = 330 \text{ nF}$ , $V_{GE} = \pm 15 \text{ V}$ , $L_\sigma = 200 \text{ nH}$ , inductive load	$T_{vj} = 25 \text{ }^\circ\text{C}$	530		ns
			$T_{vj} = 125 \text{ }^\circ\text{C}$	540		ns
Turn-off delay time	$t_{d(off)}$	$V_{CC} = 2800 \text{ V}$ , $I_C = 2000 \text{ A}$ , $R_G = 8.2 \text{ } \Omega$ , $C_{GE} = 330 \text{ nF}$ , $V_{GE} = \pm 15 \text{ V}$ , $L_\sigma = 200 \text{ nH}$ , inductive load	$T_{vj} = 25 \text{ }^\circ\text{C}$	3990		ns
			$T_{vj} = 125 \text{ }^\circ\text{C}$	4410		ns
Fall time	$t_f$	$V_{CC} = 2800 \text{ V}$ , $I_C = 2000 \text{ A}$ , $R_G = 8.2 \text{ } \Omega$ , $C_{GE} = 330 \text{ nF}$ , $V_{GE} = \pm 15 \text{ V}$ , $L_\sigma = 200 \text{ nH}$ , inductive load	$T_{vj} = 25 \text{ }^\circ\text{C}$	710		ns
			$T_{vj} = 125 \text{ }^\circ\text{C}$	800		ns
Turn-on switching energy	$E_{on}$	$V_{CC} = 2800 \text{ V}$ , $I_C = 2000 \text{ A}$ , $R_G = 1.8 \text{ } \Omega$ , $C_{GE} = 330 \text{ nF}$ , $V_{GE} = \pm 15 \text{ V}$ , $L_\sigma = 200 \text{ nH}$ , inductive load	$T_{vj} = 25 \text{ }^\circ\text{C}$	8110		mJ
			$T_{vj} = 125 \text{ }^\circ\text{C}$	9960		mJ
Turn-off switching energy	$E_{off}$	$V_{CC} = 2800 \text{ V}$ , $I_C = 2000 \text{ A}$ , $R_G = 8.2 \text{ } \Omega$ , $C_{GE} = 330 \text{ nF}$ , $V_{GE} = \pm 15 \text{ V}$ , $L_\sigma = 200 \text{ nH}$ , inductive load	$T_{vj} = 25 \text{ }^\circ\text{C}$	7670		mJ
			$T_{vj} = 125 \text{ }^\circ\text{C}$	9790		mJ
Short circuit current	$I_{SC}$	$t_{psc} \leq 10 \text{ } \mu\text{s}$ , $V_{GE} = 15 \text{ V}$ , $V_{CC} = 3400 \text{ V}$ , $V_{CEM \text{ CHIP}} \leq 4500 \text{ V}$		7800		A

<sup>3)</sup> Characteristic values according to IEC 60747 - 9

<sup>4)</sup> Collector-emitter saturation voltage is given at chip level

## Diode characteristic values <sup>5)</sup>

Parameter	Symbol	Conditions	min	typ	max	Unit
Forward voltage <sup>6)</sup>	V <sub>F</sub>	I <sub>F</sub> = 2000 A	T <sub>vj</sub> = 25 °C	2.6	2.9	V
			T <sub>vj</sub> = 125 °C	3.0	3.4	V
Peak reverse recovery current	I <sub>RM</sub>		T <sub>vj</sub> = 25 °C	1670		A
			T <sub>vj</sub> = 125 °C	1950		A
Recovered charge	Q <sub>r</sub>	V <sub>CC</sub> = 2800 V, I <sub>F</sub> = 2000 A, V <sub>GE</sub> = ±15 V, R <sub>G</sub> = 1.8 Ω, C <sub>GE</sub> = 330 nF, di/dt = 3.8 kA/μs L <sub>σ</sub> = 200 nH, inductive load	T <sub>vj</sub> = 25 °C	1770		μC
			T <sub>vj</sub> = 125 °C	2710		μC
Reverse recovery time	t <sub>rr</sub>		T <sub>vj</sub> = 25 °C	2030		ns
			T <sub>vj</sub> = 125 °C	2340		ns
Reverse recovery energy	E <sub>rec</sub>		T <sub>vj</sub> = 25 °C	2930		mJ
			T <sub>vj</sub> = 125 °C	4690		mJ

<sup>5)</sup> Characteristic values according to IEC 60747 - 2

<sup>6)</sup> Forward voltage is given at chip level

## Package properties

Parameter	Symbol	Conditions	min	typ	max	Unit
IGBT thermal resistance junction to case	R <sub>th(j-c)IGBT</sub>				0.0048	K/W
Diode thermal resistance junction to case	R <sub>th(j-c)DIODE</sub>				0.0091	K/W
IGBT thermal resistance <sup>2)</sup> case to heatsink	R <sub>th(c-h)IGBT</sub>	Heatsink flatness : Complete module area < 100 μm Each submodule area < 20 μm Roughness : < 1.6 μm		0.0011		K/W
Diode thermal resistance <sup>2)</sup> case to heatsink	R <sub>th(c-h)DIODE</sub>			0.0023		K/W
Comparative tracking index	CTI		600			

<sup>2)</sup> for detailed mounting instructions refer to ABB Document No. 5SYA 2037-02

## Mechanical properties

Parameter	Symbol	Conditions	min	typ	max	Unit
Dimensions	L x W x H	Typical	device clamped	246.95 x 237.3 x 28.75		mm
			device unclamped	246.95 x 237.3 x 31.5		
Clearance distance in air	d <sub>a</sub>	according to IEC 60664-1 and EN 50124-1	23			mm
Surface creepage distance	d <sub>s</sub>	according to IEC 60664-1 and EN 50124-1	40			mm
Mass	m			3700		g

## Electrical configuration

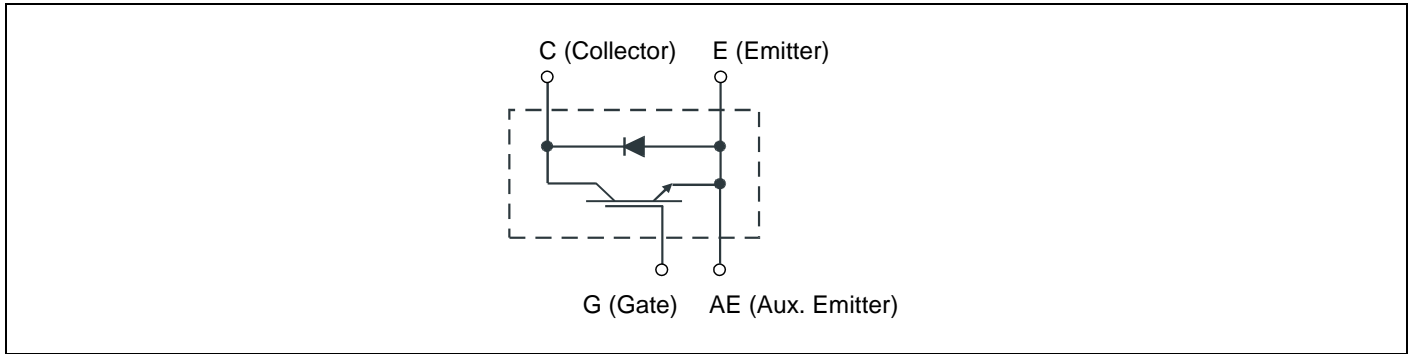

## Outline drawing <sup>2)</sup>

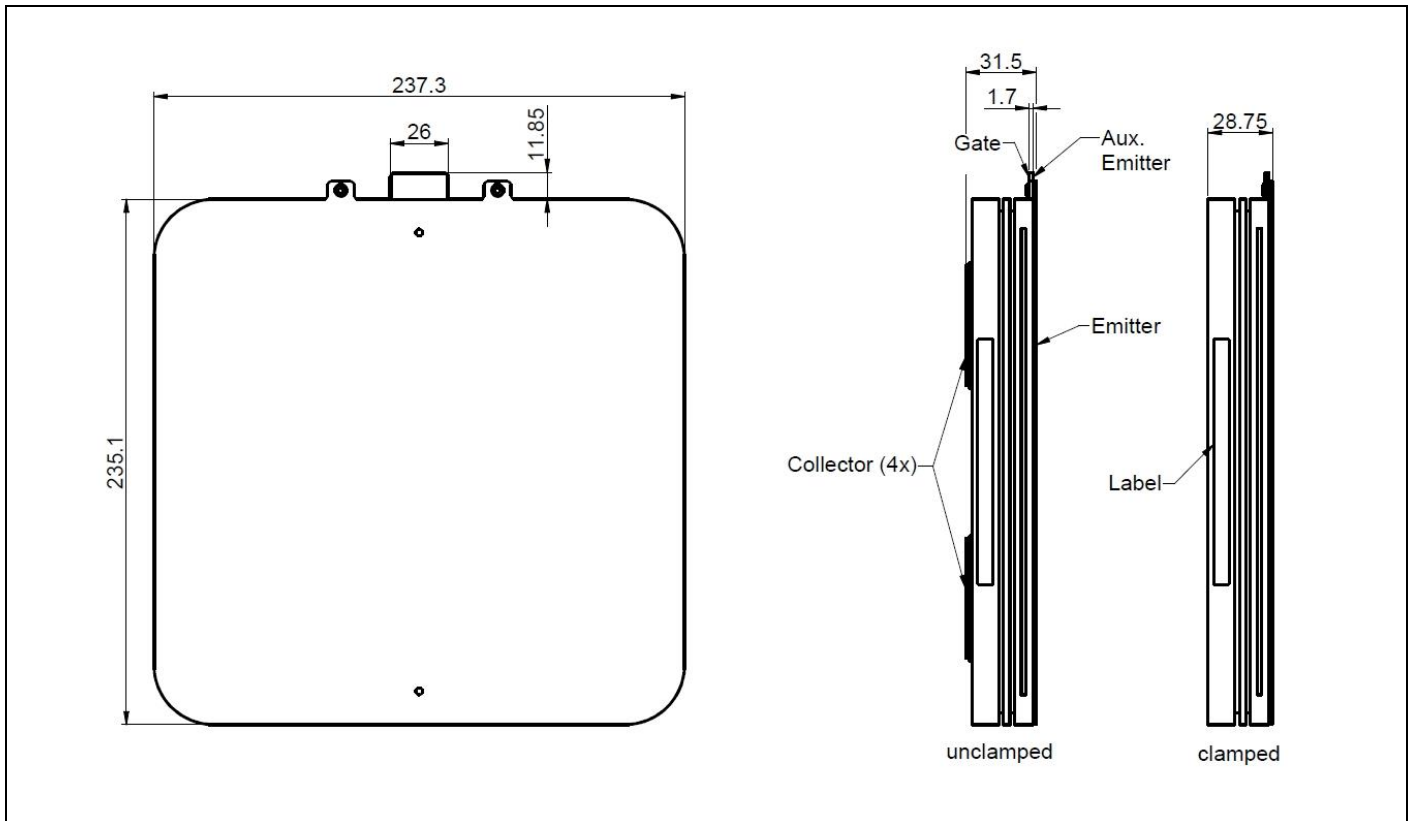

Note: all dimensions are shown in millimeters

<sup>2)</sup> For detailed mounting instructions refer to ABB Document No. 5SYA 2039

This is an electrostatic sensitive device; please observe the international standard IEC 60747-1, chap. VIII.  
This product has been designed and qualified for Industrial Level.

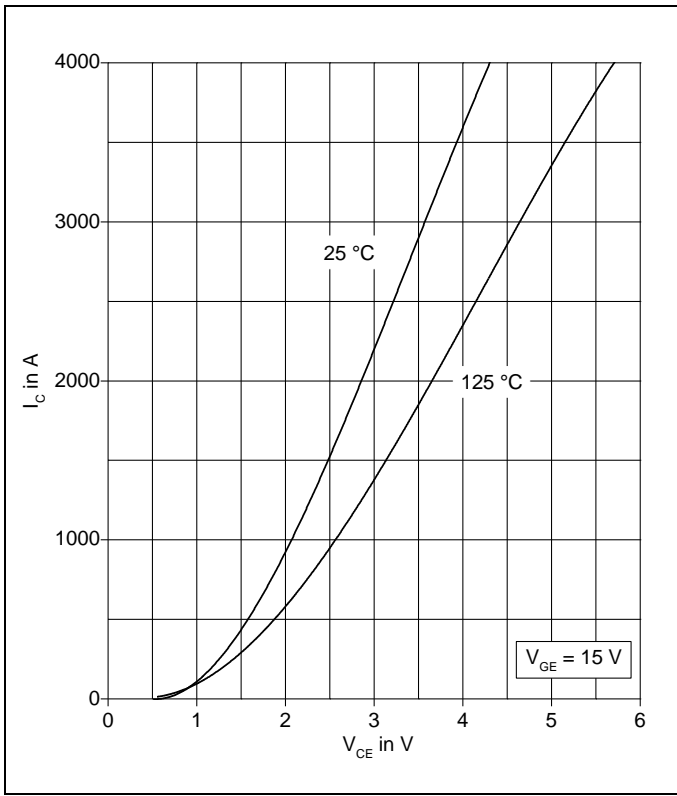

Fig. 1 Typical on-state characteristics, chip level

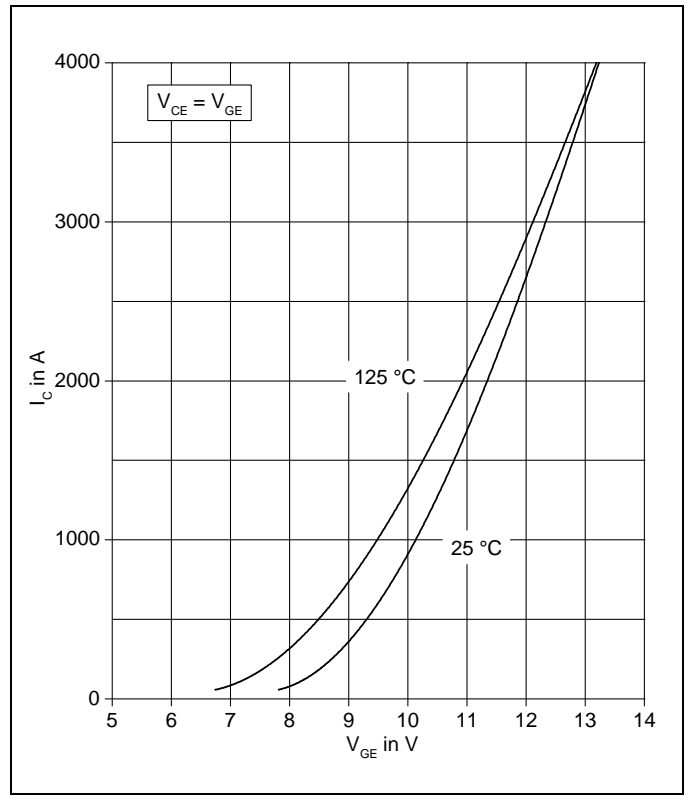

Fig. 2 Typical transfer characteristics, chip level

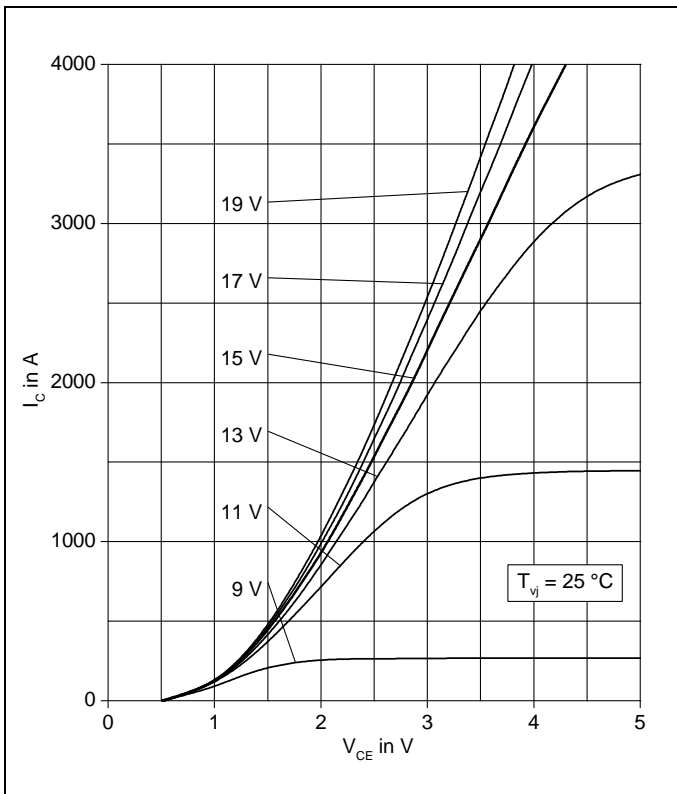

Fig. 3 Typical output characteristics, chip level

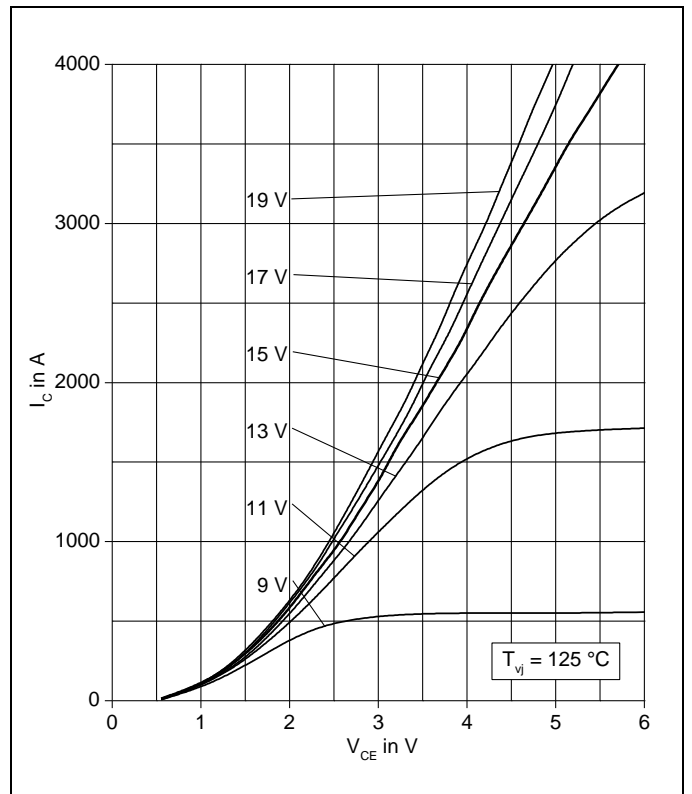

Fig. 4 Typical output characteristics, chip level

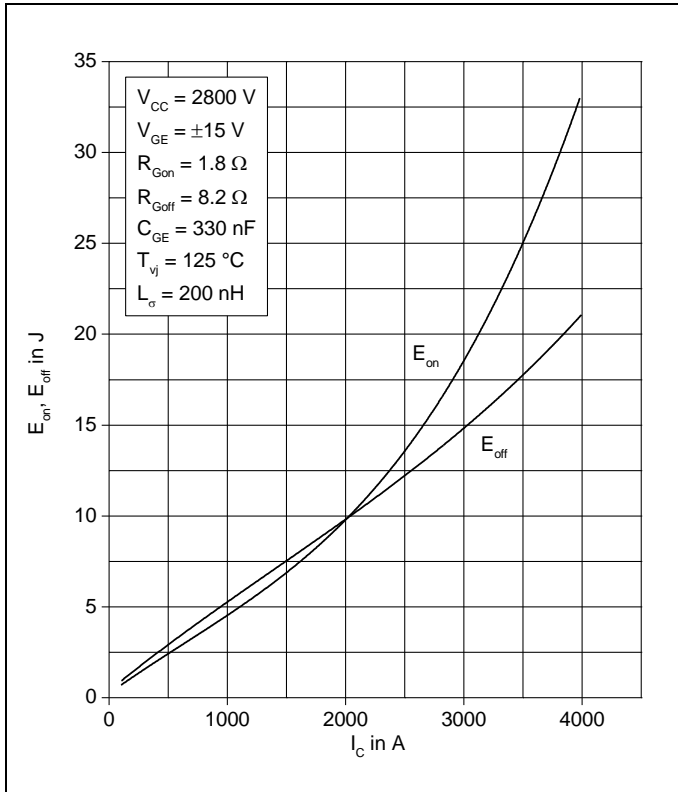

Fig. 5 Typical switching energies per pulse vs. collector current

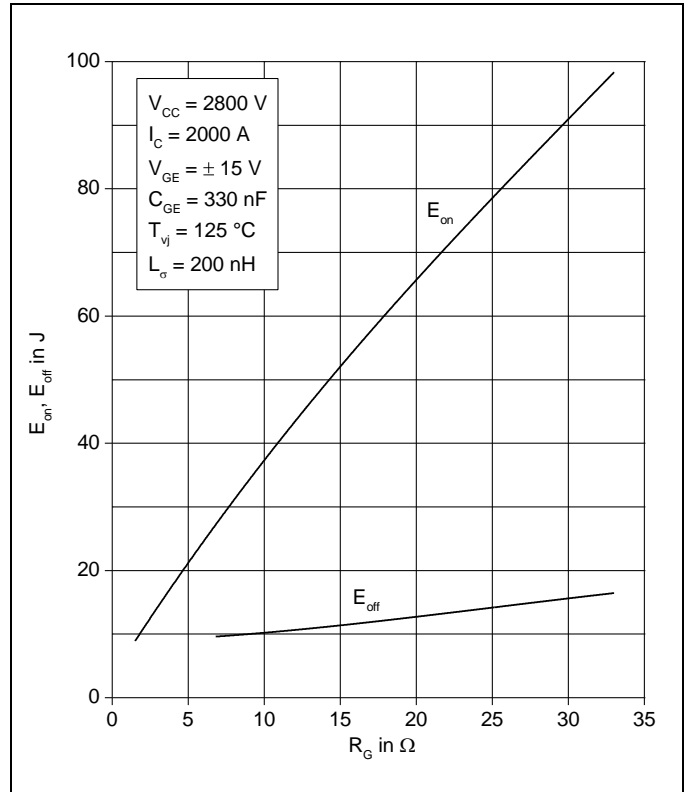

Fig. 6 Typical switching energies per pulse vs. gate resistor

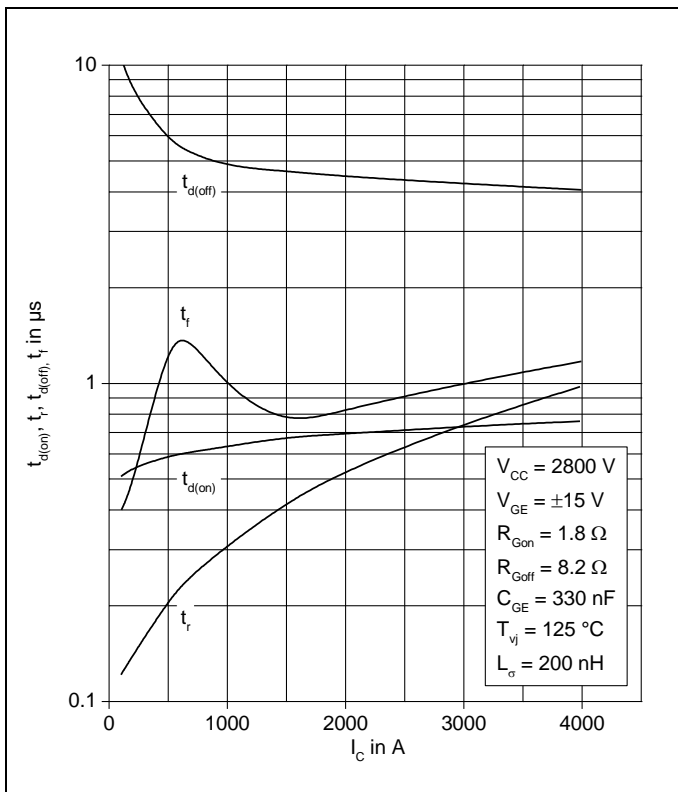

Fig. 7 Typical switching times vs. collector current

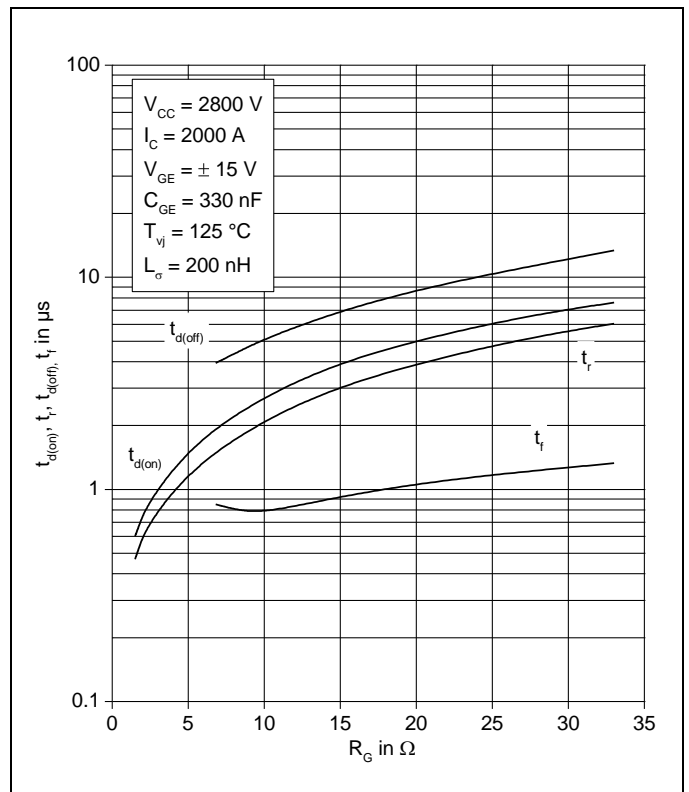

Fig. 8 Typical switching times vs. gate resistor

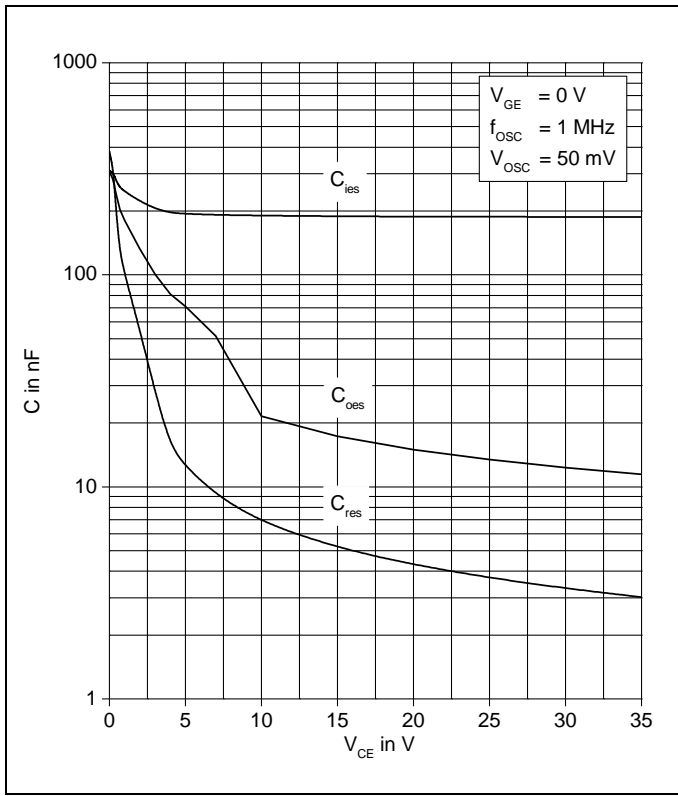

Fig. 9 Typical capacitances vs. collector-emitter voltage

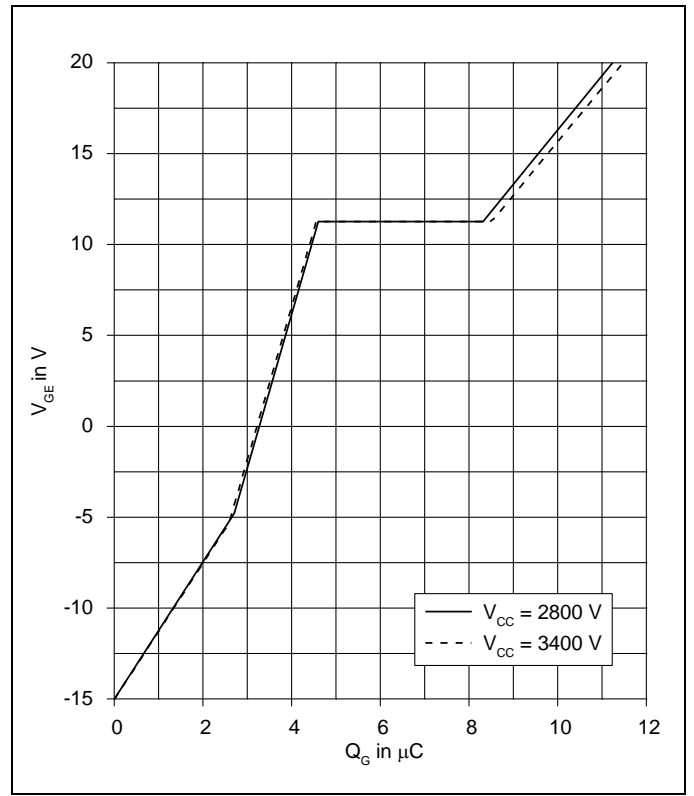

Fig. 10 Typical gate charge characteristics

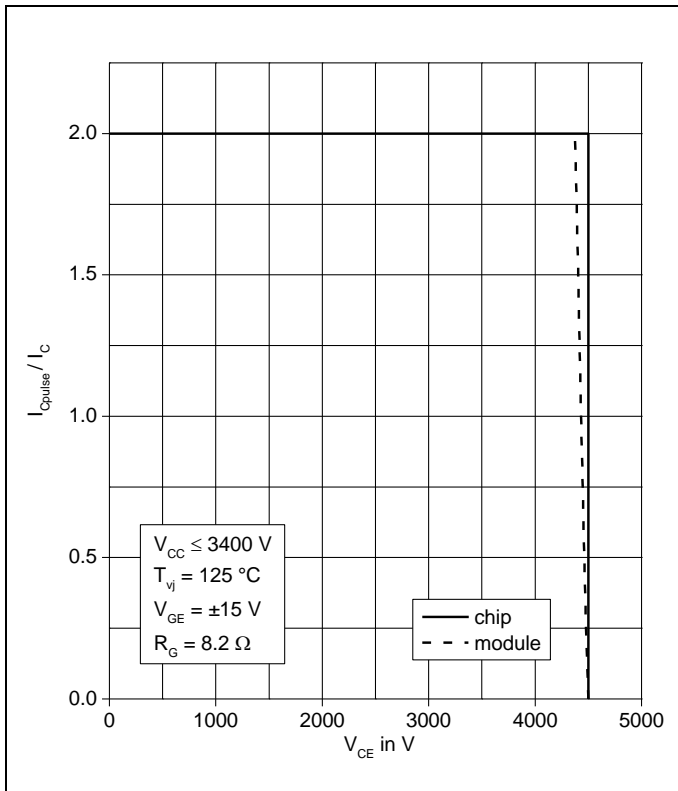

Fig. 11 Turn-off safe operating area (RBSOA)

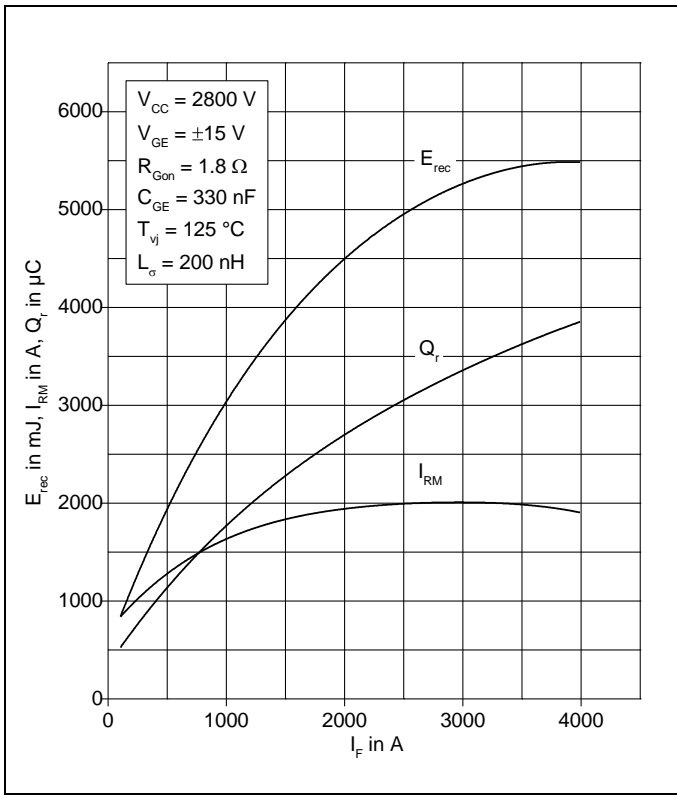

Fig. 12 Typical reverse recovery characteristics vs. forward current

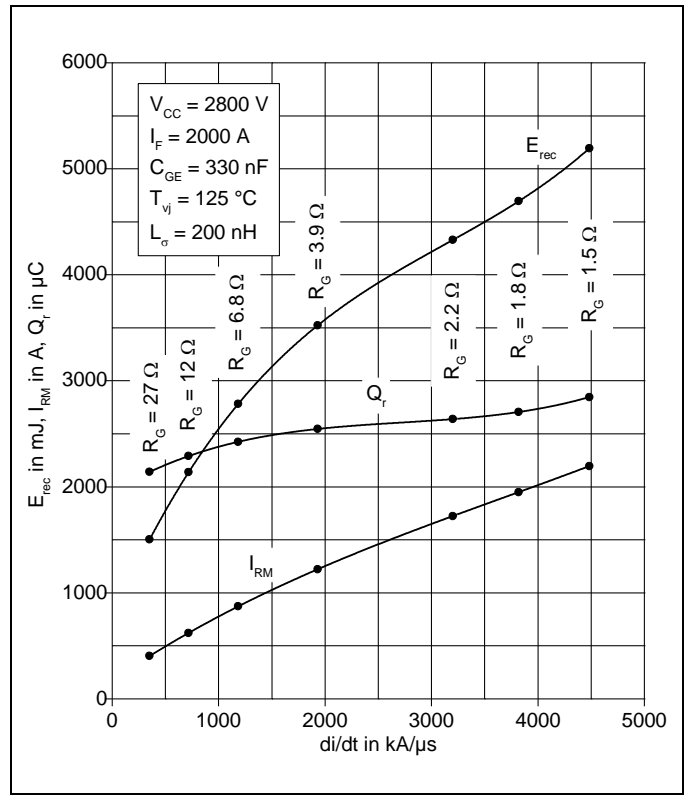

Fig. 13 Typical reverse recovery characteristics vs. di/dt

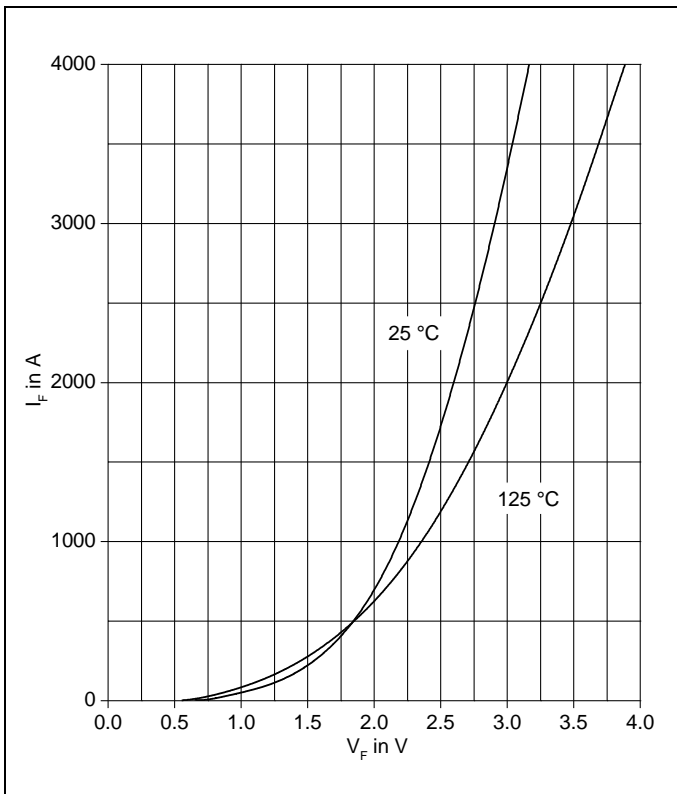

Fig. 14 Typical diode forward characteristics chip level

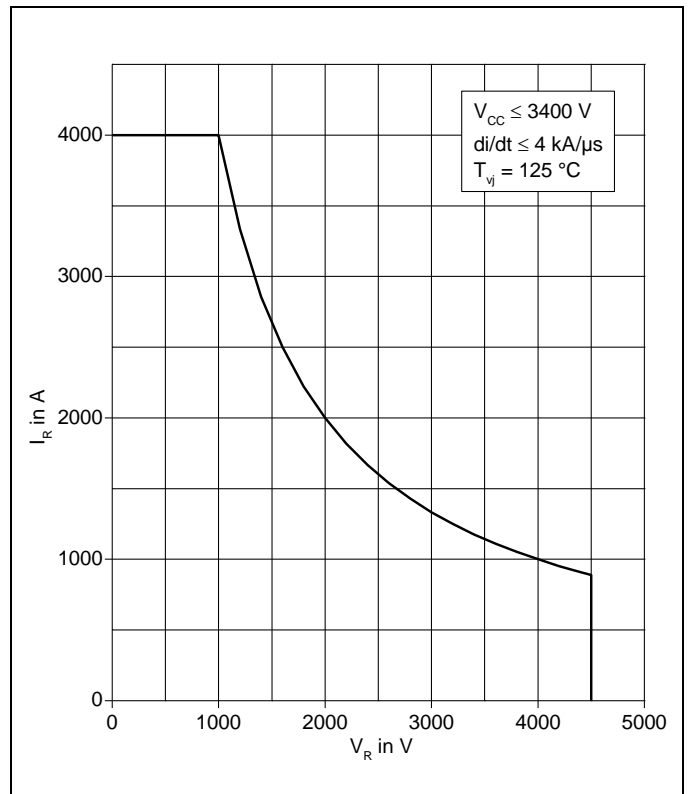

Fig. 15 Safe operating area diode (SOA)



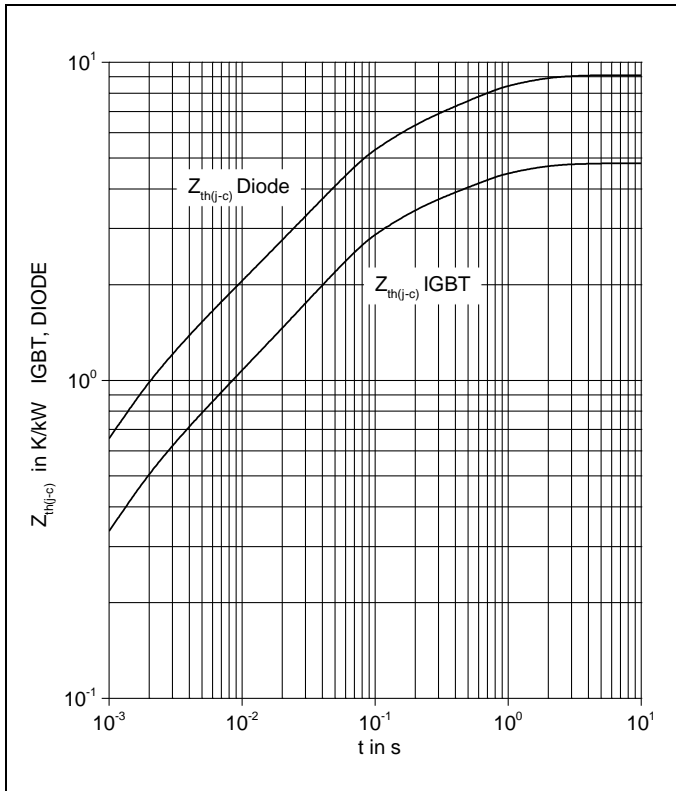

Fig. 16 Thermal impedance vs. time

Analytical function for transient thermal impedance:

$$Z_{th(j-c)}(t) = \sum_{i=1}^n R_i (1 - e^{-t/\tau_i})$$

	i	1	2	3	4	5
IGBT	\$R_i\$ in K/kW	1.801	2.234	0.403	0.369	
	\$\tau_i\$ in s	0.581	0.059	0.006	0.001	
DIODE	\$R_i\$ in K/kW	3.614	3.958	0.803	0.727	
	\$\tau_i\$ in s	0.584	0.059	0.006	0.001	

ABB Switzerland Ltd.  
Semiconductors  
Fabrikstrasse 3  
CH-5600 Lenzburg  
Switzerland

Phone: +41 58 586 1419  
Fax: +41 58 586 1306  
E-Mail: [abbsem@ch.abb.com](mailto:abbsem@ch.abb.com)  
Internet: [www.abb.com/semiconductors](http://www.abb.com/semiconductors)

We reserve the right to make technical changes or to modify the contents of this document without prior notice.

We reserve all rights in this document and the information contained therein. Any reproduction or utilization of this document or parts thereof for commercial purposes without our prior written consent is forbidden.

Any liability for use of our products contrary to the instructions in this document is excluded.

## X-ON Electronics

Largest Supplier of Electrical and Electronic Components

*Click to view similar products for [IGBT Modules category](#):*

*Click to view products by [ABB manufacturer](#):*

Other Similar products are found below :

[F3L400R07ME4\\_B22](#) [F4-50R07W2H3\\_B51](#) [FB15R06W1E3](#) [FB20R06W1E3\\_B11](#) [FD1000R33HE3-K](#) [FD400R12KE3](#) [FD400R33KF2C-K](#)  
[FD401R17KF6C\\_B2](#) [FD-DF80R12W1H3\\_B52](#) [FF200R06YE3](#) [FF450R12ME4P](#) [FF600R12IP4V](#) [FP06R12W1T4\\_B3](#) [FP10R06W1E3\\_B11](#)  
[FP15R12W2T4](#) [FP20R06W1E3](#) [FP75R07N2E4\\_B11](#) [FS10R12YE3](#) [FS150R07PE4](#) [FS150R12PT4](#) [FS20R06W1E3\\_B11](#) [FS50R07N2E4](#)  
[FS50R07N2E4\\_B11](#) [FZ1000R33HE3](#) [FZ1800R17KF4](#) [DD250S65K3](#) [DF1000R17IE4](#) [DF1000R17IE4D\\_B2](#) [DF1400R12IP4D](#)  
[DF200R12PT4\\_B6](#) [DF400R07PE4R\\_B6](#) [BSM75GB120DN2\\_E3223c-Se](#) [F3L300R12ME4\\_B22](#) [F3L75R07W2E3\\_B11](#) [F4-50R12KS4\\_B11](#)  
[FD1400R12IP4D](#) [FD200R12PT4\\_B6](#) [FD800R33KF2C-K](#) [FF150R12ME3G](#) [FF300R17KE3\\_S4](#) [FF300R17ME4\\_B11](#) [FF401R17KF6C\\_B2](#)  
[FF650R17IE4D\\_B2](#) [FF900R12IP4D](#) [FF900R12IP4DV](#) [FP30R06W1E3\\_B11](#) [FP50R07N2E4\\_B11](#) [FS100R07PE4](#) [FS150R07N3E4\\_B11](#)  
[FS150R17N3E4](#)