

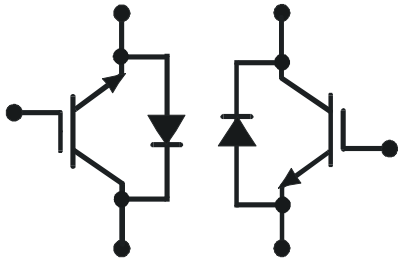
$V_{CE} = 1700\text{ V}$

$I_C = 800\text{ A}$

# HiPak

## IGBT Module

# 5SND 0800M170100



Doc. No. 5SYA1589-02 10 2020

- Low-loss, rugged SPT chip-set
- Smooth switching SPT chip-set for good EMC
- Industry standard package
- High power density
- AISiC base-plate for high power cycling capability
- AlN substrate for low thermal resistance
- 2 switches in one package
- Improved high reliability package
- Recognized under UL1557, File E196689



### Maximum rated values <sup>1)</sup>

Parameter	Symbol	Conditions	min	max	Unit
Collector-emitter voltage	$V_{CES}$	$V_{GE} = 0\text{ V}$ , $T_{vj} \geq 25\text{ °C}$		1700	V
DC collector current	$I_C$	$T_c = 80\text{ °C}$		800	A
Peak collector current	$I_{CM}$	$t_p = 1\text{ ms}$ , $T_c = 80\text{ °C}$		1600	A
Gate-emitter voltage	$V_{GES}$		-20	20	V
Total power dissipation	$P_{tot}$	$T_c = 25\text{ °C}$ , per switch (IGBT)		4800	W
DC forward current	$I_F$			800	A
Peak forward current	$I_{FRM}$			1600	A
Surge current	$I_{FSM}$	$V_R = 0\text{ V}$ , $T_{vj} = 125\text{ °C}$ , $t_p = 10\text{ ms}$ , half-sinewave		6600	A
IGBT short circuit SOA	$t_{psc}$	$V_{CC} = 1200\text{ V}$ , $V_{CEMCHIP} \leq 1700\text{ V}$ $V_{GE} \leq 15\text{ V}$ , $T_{vj} \leq 125\text{ °C}$		10	$\mu\text{s}$
Isolation voltage	$V_{isol}$	1 min, $f = 50\text{ Hz}$		4000	V
Junction temperature	$T_{vj}$			150	$^{\circ}\text{C}$
Junction operating temperature	$T_{vj(op)}$		-40	125	$^{\circ}\text{C}$
Case temperature	$T_c$		-40	125	$^{\circ}\text{C}$
Storage temperature	$T_{stg}$		-40	125	$^{\circ}\text{C}$
Mounting torques <sup>2)</sup>	$M_s$	Base-heatsink, M6 screws	4	6	Nm
	$M_{t1}$	Main terminals, M8 screws	8	10	
	$M_{t2}$	Auxiliary terminals, M4 screws	2	3	

<sup>1)</sup> Maximum rated values indicate limits beyond which damage to the device may occur per IEC 60747

<sup>2)</sup> For detailed mounting instructions refer to document no. 5SYA 2039 - 01

IGBT characteristic values <sup>3)</sup>

Parameter	Symbol	Conditions	min	typ	max	Unit	
Collector (-emitter) breakdown voltage	$V_{(BR)CES}$	$V_{GE} = 0 \text{ V}$ , $I_C = 10 \text{ mA}$ , $T_{vj} = 25 \text{ °C}$	1700			V	
Collector-emitter <sup>4)</sup> saturation voltage	$V_{CE \text{ sat}}$	$I_C = 800 \text{ A}$ , $V_{GE} = 15 \text{ V}$	$T_{vj} = 25 \text{ °C}$	2.0	2.3	2.6	V
			$T_{vj} = 125 \text{ °C}$	2.3	2.6	2.9	V
Collector cut-off current	$I_{CES}$	$V_{CE} = 1700 \text{ V}$ , $V_{GE} = 0 \text{ V}$	$T_{vj} = 25 \text{ °C}$			4	mA
			$T_{vj} = 125 \text{ °C}$			40	mA
Gate leakage current	$I_{GES}$	$V_{CE} = 0 \text{ V}$ , $V_{GE} = \pm 20 \text{ V}$ , $T_{vj} = 125 \text{ °C}$	-500		500	nA	
Gate-emitter threshold voltage	$V_{GE(TO)}$	$I_C = 80 \text{ mA}$ , $V_{CE} = V_{GE}$ , $T_{vj} = 25 \text{ °C}$	4.5		6.5	V	
Gate charge	$Q_{ge}$	$I_C = 800 \text{ A}$ , $V_{CE} = 900 \text{ V}$ , $V_{GE} = -15 \text{ V} \dots 15 \text{ V}$		7.3		$\mu\text{C}$	
Input capacitance	$C_{ies}$	$V_{CE} = 25 \text{ V}$ , $V_{GE} = 0 \text{ V}$ , $f = 1 \text{ MHz}$ , $T_{vj} = 25 \text{ °C}$		76		nF	
Output capacitance	$C_{oes}$			7.3			
Reverse transfer capacitance	$C_{res}$			3.2			
Turn-on delay time	$t_{d(on)}$	$V_{CC} = 900 \text{ V}$ , $I_C = 800 \text{ A}$ , $R_G = 1.2 \text{ }\Omega$ ,	$T_{vj} = 25 \text{ °C}$	485		ns	
			$T_{vj} = 125 \text{ °C}$	485			
Rise time	$t_r$	$V_{GE} = \pm 15 \text{ V}$ , $L_\sigma = 80 \text{ nH}$ , inductive load	$T_{vj} = 25 \text{ °C}$	165		ns	
			$T_{vj} = 125 \text{ °C}$	170			
Turn-off delay time	$t_{d(off)}$	$V_{CC} = 900 \text{ V}$ , $I_C = 800 \text{ A}$ , $R_G = 1.8 \text{ }\Omega$ ,	$T_{vj} = 25 \text{ °C}$	790		ns	
			$T_{vj} = 125 \text{ °C}$	875			
Fall time	$t_f$	$V_{GE} = \pm 15 \text{ V}$ , $L_\sigma = 80 \text{ nH}$ , inductive load	$T_{vj} = 25 \text{ °C}$	160		ns	
			$T_{vj} = 125 \text{ °C}$	185			
Turn-on switching energy	$E_{on}$	$V_{CC} = 900 \text{ V}$ , $I_C = 800 \text{ A}$ , $V_{GE} = \pm 15 \text{ V}$ , $R_G = 1.2 \text{ }\Omega$ , $L_\sigma = 80 \text{ nH}$ , inductive load	$T_{vj} = 25 \text{ °C}$	160		mJ	
			$T_{vj} = 125 \text{ °C}$	250			
Turn-off switching energy	$E_{off}$	$V_{CC} = 900 \text{ V}$ , $I_C = 800 \text{ A}$ , $V_{GE} = \pm 15 \text{ V}$ , $R_G = 1.8 \text{ }\Omega$ , $L_\sigma = 80 \text{ nH}$ , inductive load	$T_{vj} = 25 \text{ °C}$	220		mJ	
			$T_{vj} = 125 \text{ °C}$	300			
Short circuit current	$I_{SC}$	$t_{psc} \leq 10 \text{ }\mu\text{s}$ , $V_{GE} = 15 \text{ V}$ , $T_{vj} = 125 \text{ °C}$ , $V_{CC} = 1200 \text{ V}$ , $V_{CEM \text{ CHIP}} \leq 1700 \text{ V}$		3600		A	
Module stray inductance	$L_{\sigma \text{ CE}}$	per switch		24		nH	
Resistance, terminal-chip	$R_{CC+EE'}$	per switch	$T_C = 25 \text{ °C}$	0.18		m $\Omega$	
			$T_C = 125 \text{ °C}$	0.255			

<sup>3)</sup> Characteristic values according to IEC 60747 – 9<sup>4)</sup> Collector-emitter saturation voltage is given at chip level

**Diode characteristic values** <sup>5)</sup>

Parameter	Symbol	Conditions	min	typ	max	Unit
Forward voltage <sup>6)</sup>	$V_F$	$I_F = 800 \text{ A}$	$T_{vj} = 25 \text{ }^\circ\text{C}$	1.65	2.0	V
			$T_{vj} = 125 \text{ }^\circ\text{C}$		1.7	
Reverse recovery current	$I_{rr}$	$V_{CC} = 900 \text{ V},$ $I_F = 800 \text{ A},$ $V_{GE} = \pm 15 \text{ V},$ $R_G = 1.2 \text{ } \Omega$ $L_\sigma = 80 \text{ nH}$ inductive load	$T_{vj} = 25 \text{ }^\circ\text{C}$	560		A
			$T_{vj} = 125 \text{ }^\circ\text{C}$	730		
Recovered charge	$Q_{rr}$		$T_{vj} = 25 \text{ }^\circ\text{C}$	210		$\mu\text{C}$
			$T_{vj} = 125 \text{ }^\circ\text{C}$	385		
Reverse recovery time	$t_{rr}$		$T_{vj} = 25 \text{ }^\circ\text{C}$	690		ns
			$T_{vj} = 125 \text{ }^\circ\text{C}$	975		
Reverse recovery energy	$E_{rec}$		$T_{vj} = 25 \text{ }^\circ\text{C}$	150		mJ
			$T_{vj} = 125 \text{ }^\circ\text{C}$	270		

<sup>5)</sup> Characteristic values according to IEC 60747 – 2

<sup>6)</sup> Forward voltage is given at chip level

**Thermal properties** <sup>7)</sup>

Parameter	Symbol	Conditions	min	typ	max	Unit
IGBT thermal resistance junction to case	$R_{th(j-c)IGBT}$	per switch			0.021	K/W
Diode thermal resistance junction to case	$R_{th(j-c)DIODE}$				0.036	K/W
IGBT thermal resistance <sup>2)</sup> case to heatsink	$R_{th(c-s)IGBT}$	IGBT per switch, $\lambda$ grease = $1\text{W}/\text{m} \times \text{K}$		0.024		K/W
Diode thermal resistance <sup>7)</sup> case to heatsink	$R_{th(c-s)DIODE}$	Diode per switch, $\lambda$ grease = $1\text{W}/\text{m} \times \text{K}$		0.048		K/W

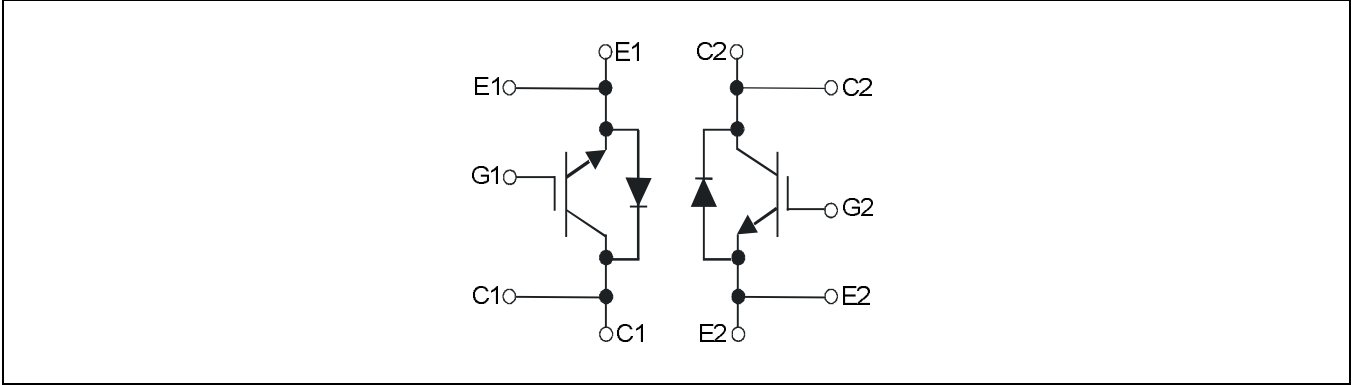
<sup>2)</sup> For detailed mounting instructions refer to document no. 5SYA 2039 - 01

**Mechanical properties** <sup>7)</sup>

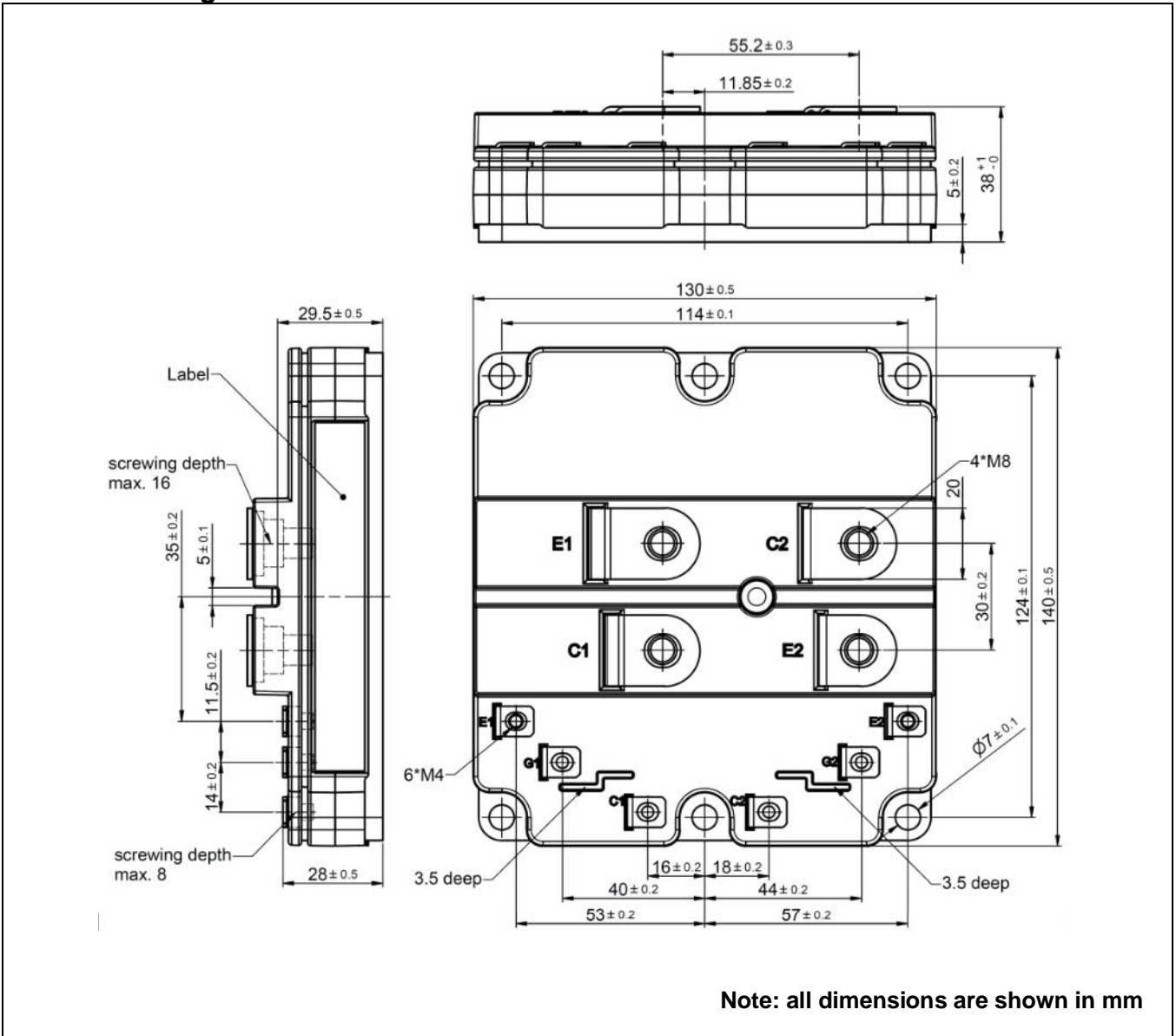
Parameter	Symbol	Conditions	min	typ	max	Unit
Dimensions	$L \times W \times H$	Typical , see outline drawing	130 x 140 x 38			mm
Comparative tracking index	CTI		600			
Clearance distance in air	$d_a$	according to IEC 60664-1 and EN 50124-1	Term. to base:	10		mm
			Term. to term:	10		
Surface creepage distance	$d_s$	according to IEC 60664-1 and EN 50124-1	Term. to base:	15		mm
			Term. to term:	15		
Mass	$m$			820		g

<sup>7)</sup> Thermal and mechanical properties according to IEC 60747 – 15

**Electrical configuration**

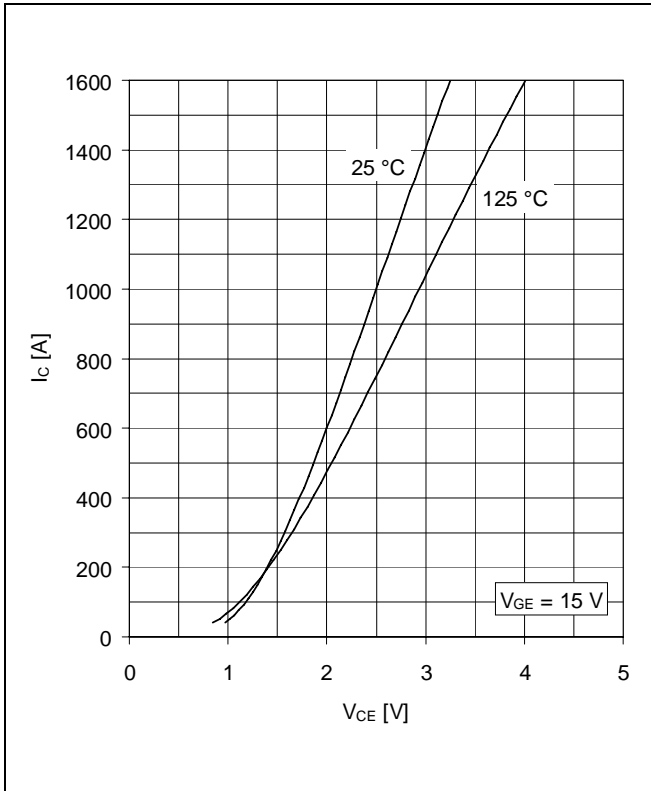


**Outline drawing <sup>2)</sup>**

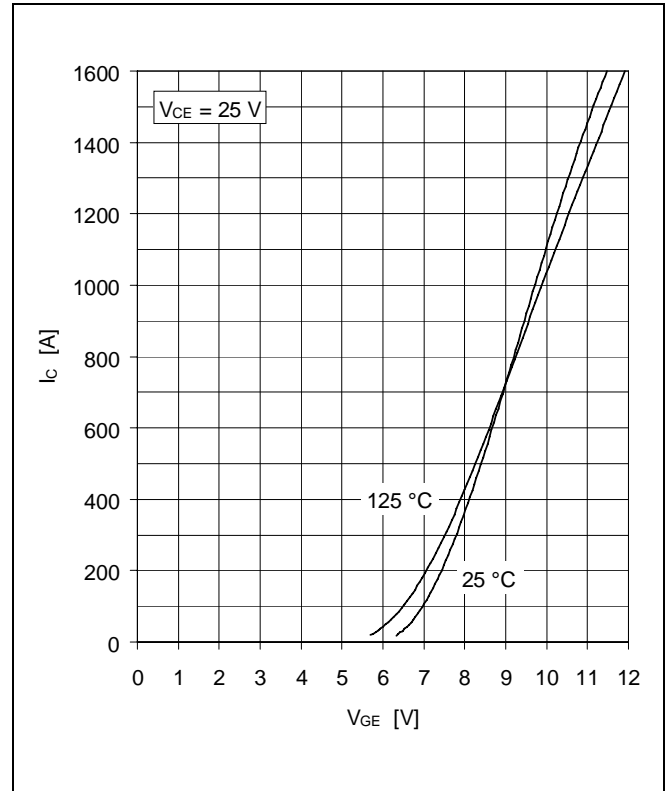


<sup>2)</sup> For detailed mounting instructions refer to document no. 5SYA 2039 - 01

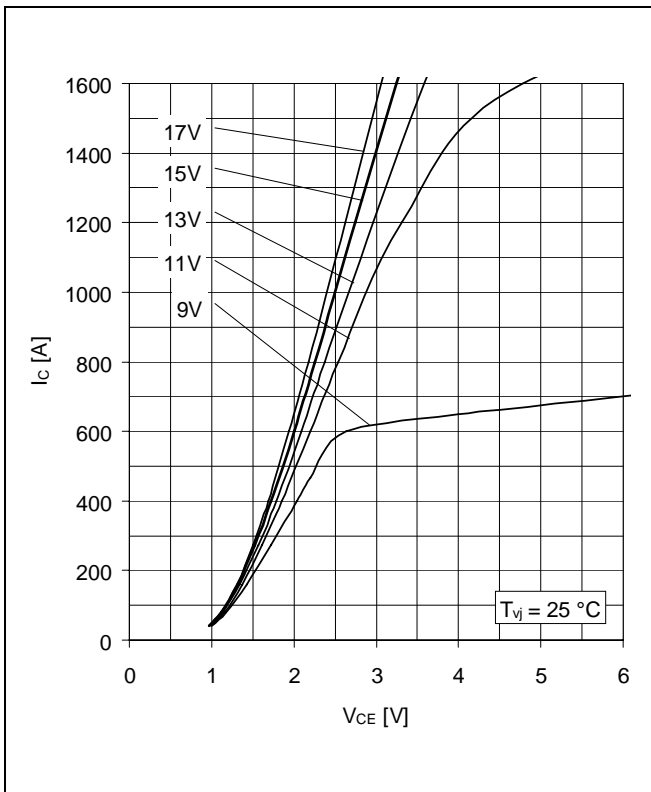
**This is an electrostatic sensitive device, please observe the international standard IEC 60747-1, chap. IX. This product has been designed and qualified for industrial level.**



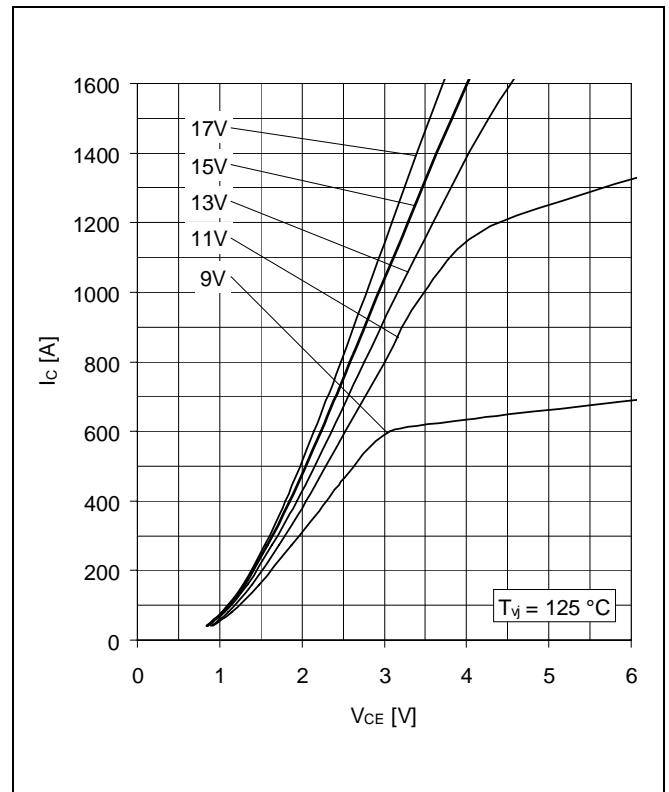
**Fig. 1** Typical on-state characteristics, chip level



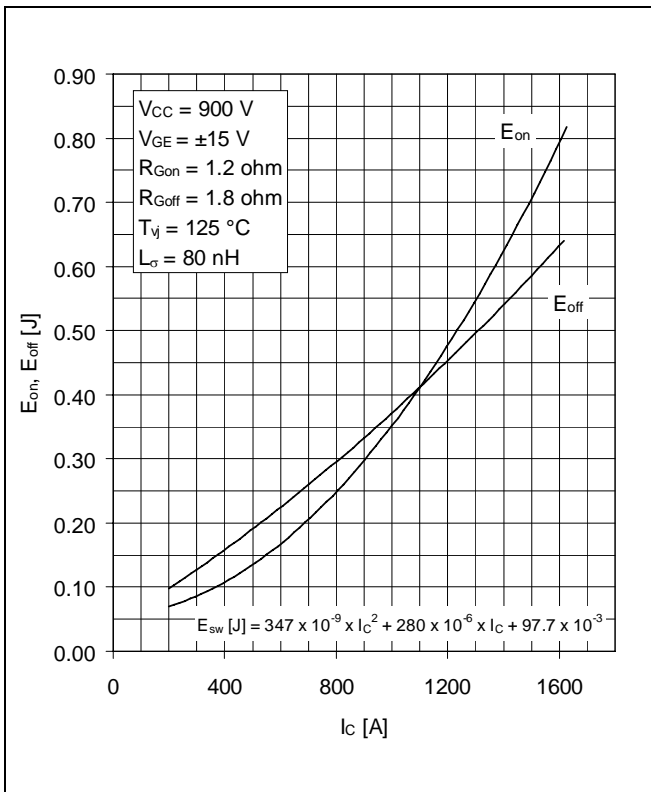
**Fig. 2** Typical transfer characteristics, chip level



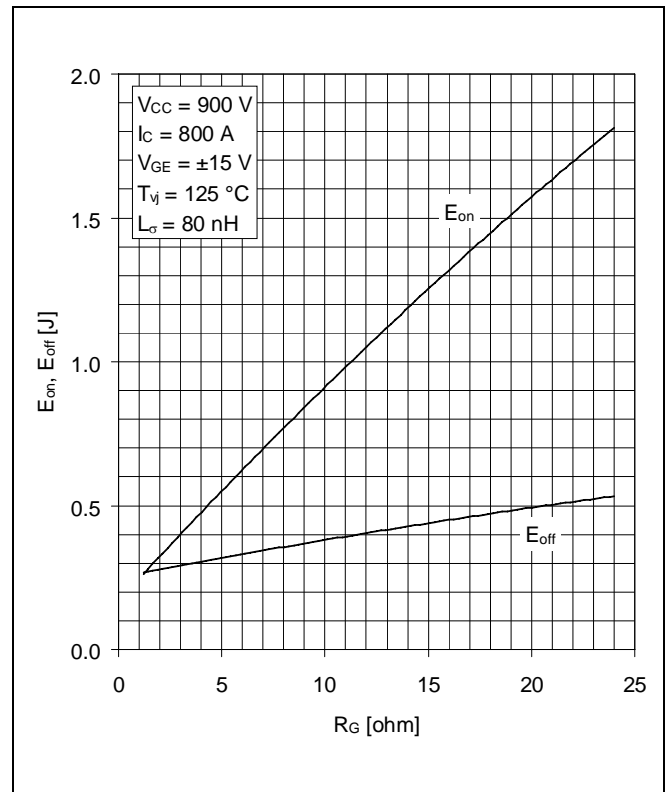
**Fig. 3** Typical output characteristics, chip level



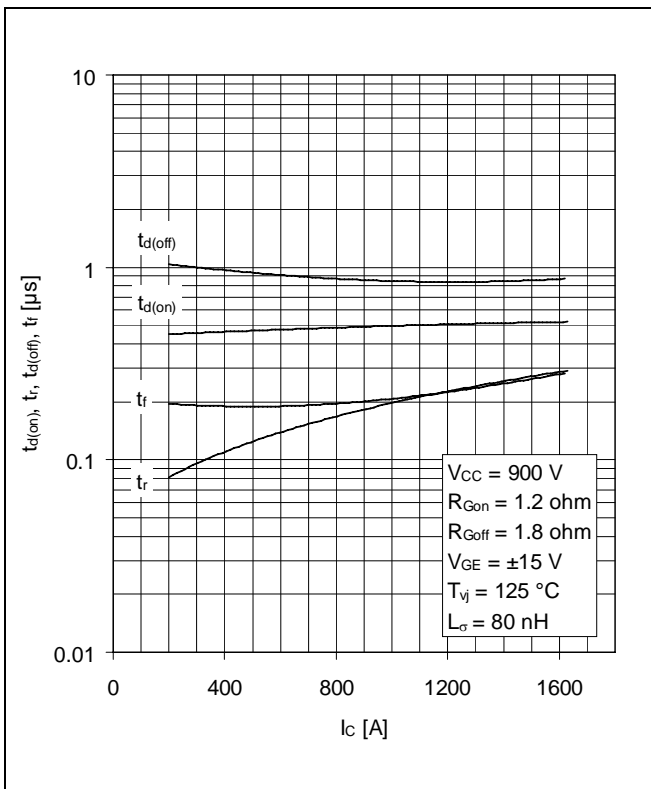
**Fig. 4** Typical output characteristics, chip level



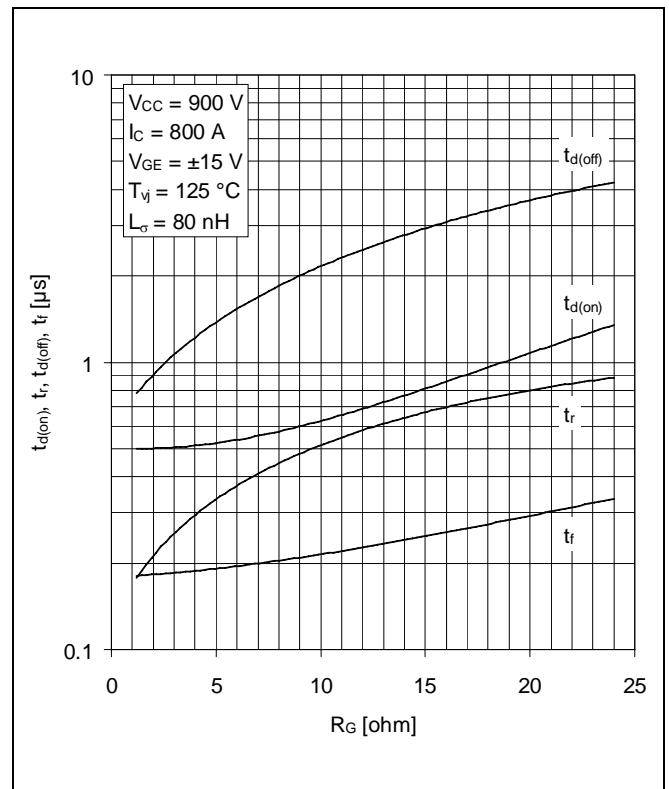
**Fig. 5** Typical switching energies per pulse vs collector current



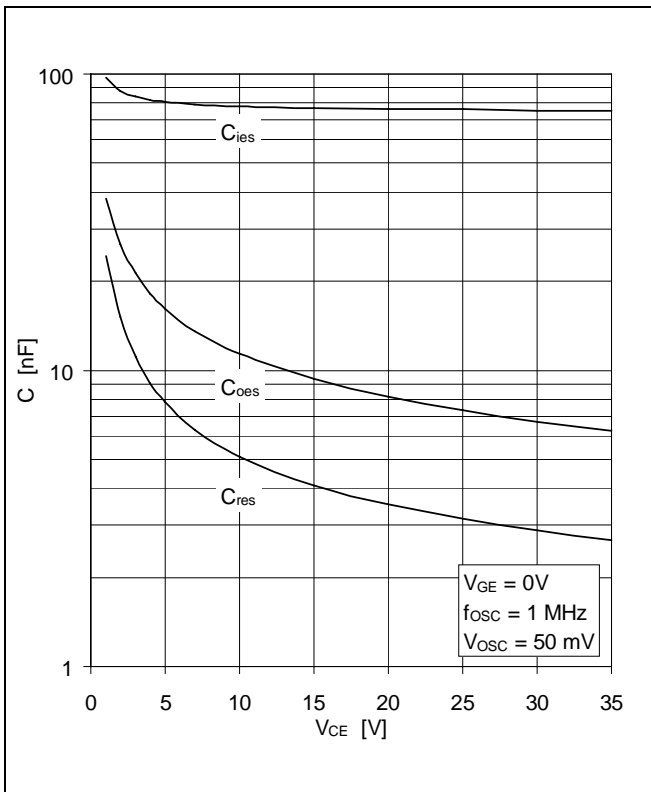
**Fig. 6** Typical switching energies per pulse vs gate resistor



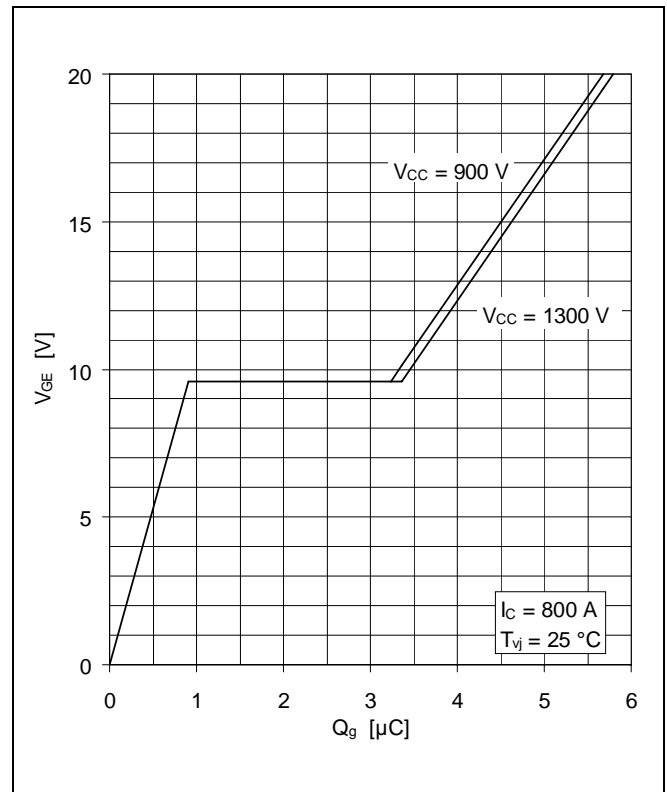
**Fig. 7** Typical switching times vs collector current



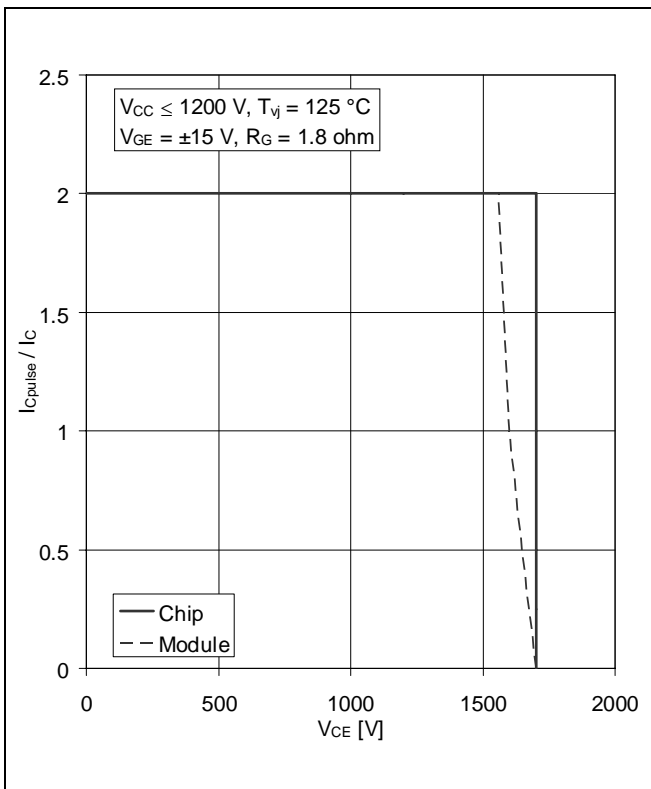
**Fig. 8** Typical switching times vs gate resistor



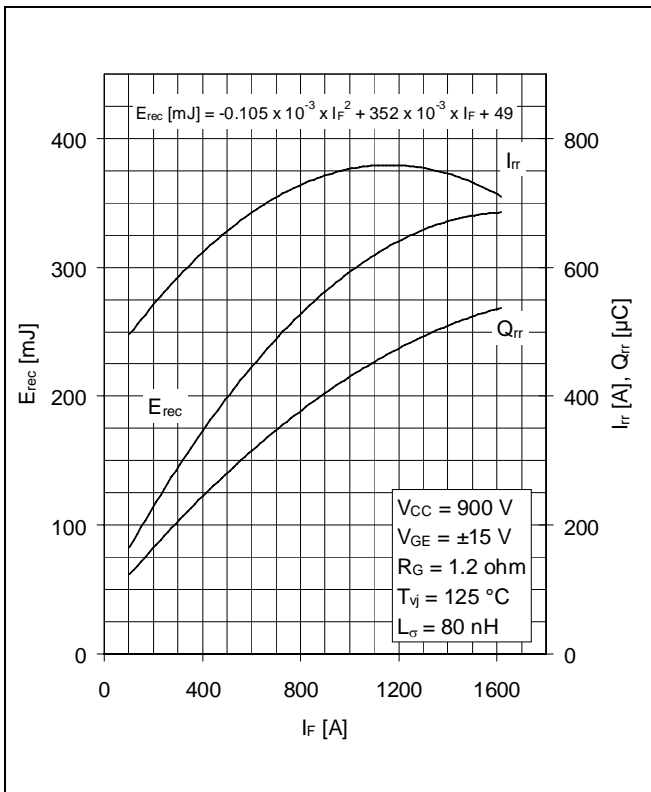
**Fig. 9** Typical capacitances vs collector-emitter voltage



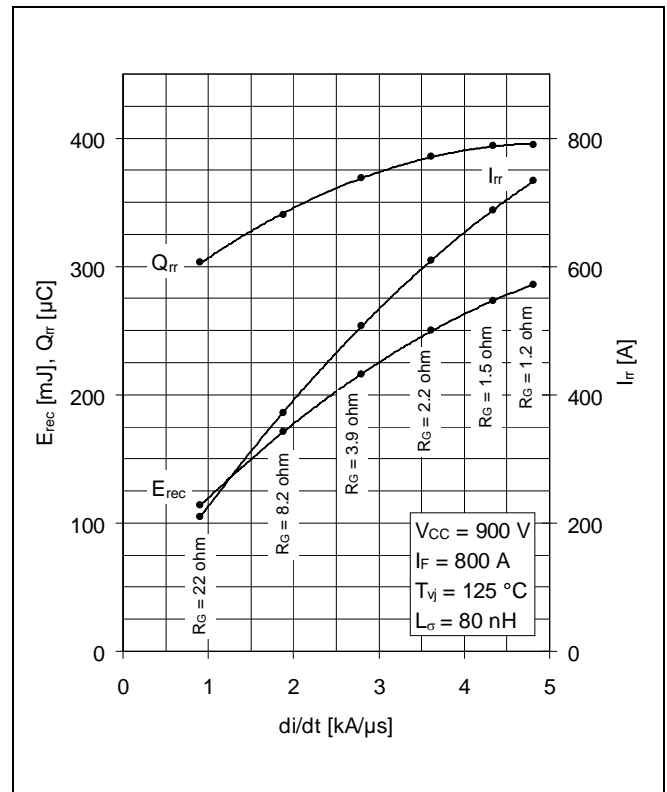
**Fig. 10** Typical gate charge characteristics



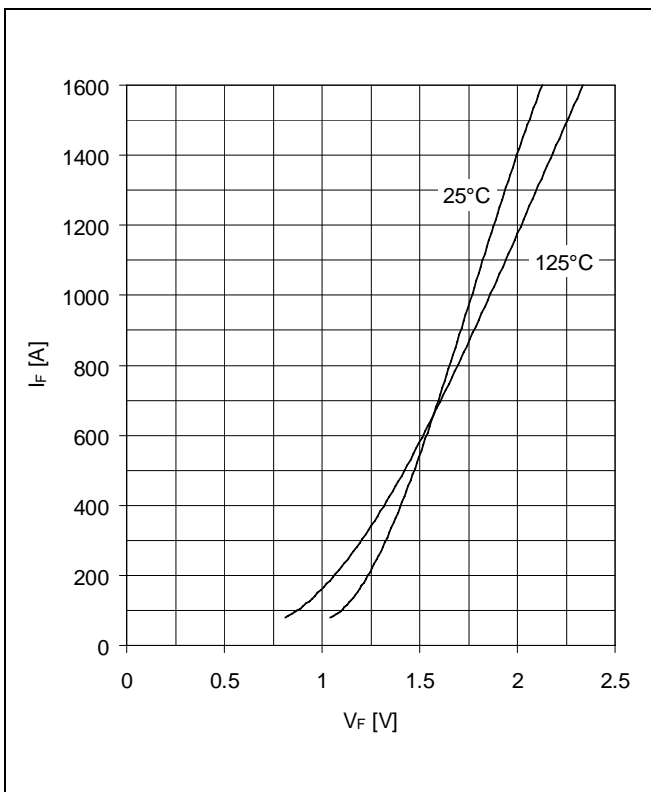
**Fig. 11** Turn-off safe operating area (RBSOA)



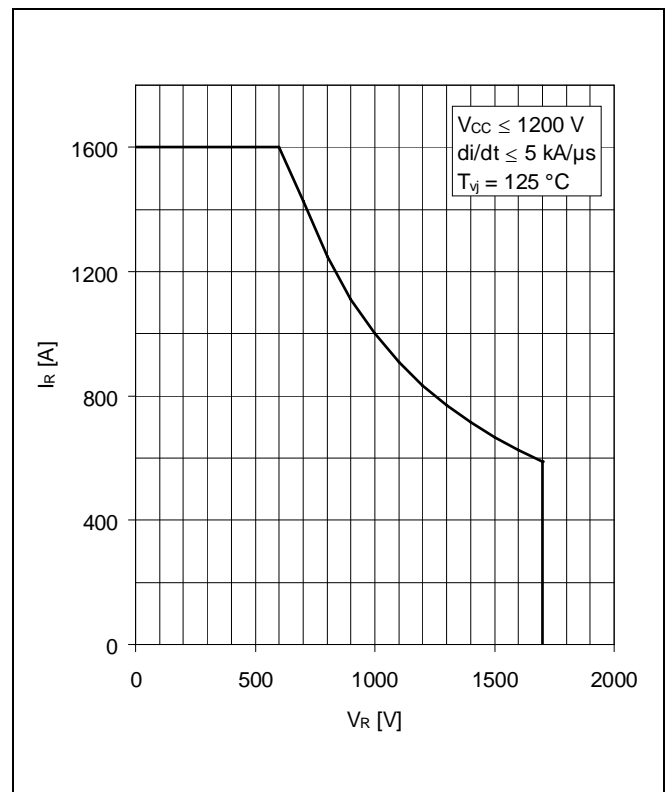
**Fig. 12** Typical reverse recovery characteristics vs forward current



**Fig. 13** Typical reverse recovery characteristics vs di/dt

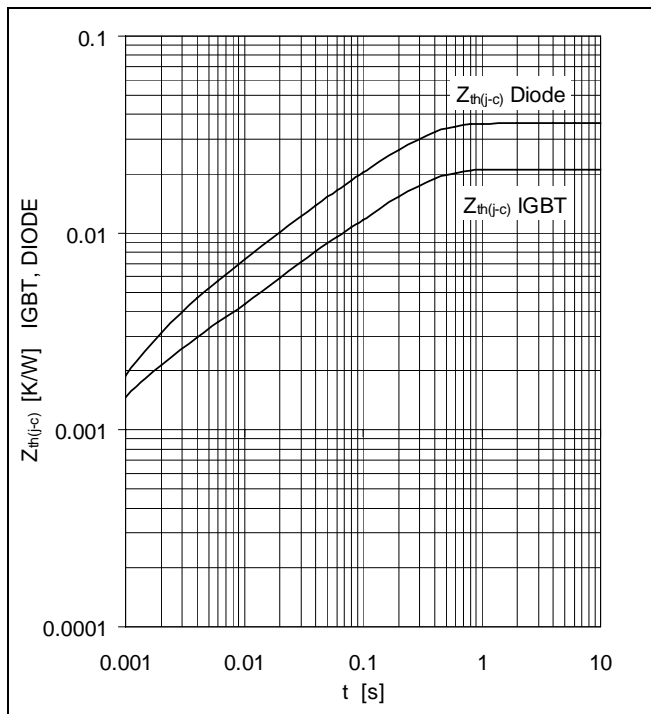


**Fig. 14** Typical diode forward characteristics, chip level



**Fig. 15** Safe operating area diode (SOA)





**Fig. 16** Thermal impedance vs time

**Analytical function for transient thermal impedance:**

$$Z_{th(j-c)}(t) = \sum_{i=1}^n R_i (1 - e^{-t/\tau_i})$$

	i	1	2	3	4	
IGBT	R <sub>i</sub> (K/kW)	15.2	3.6	1.49	0.74	
	τ <sub>i</sub> (ms)	202	20.3	2.01	0.52	
DIODE	R <sub>i</sub> (K/kW)	25.3	5.78	2.6	2.52	
	τ <sub>i</sub> (ms)	210	29.6	7.01	1.49	

**Related documents:**

- 5SYA 2042 Failure rates of HiPak modules due to cosmic rays
- 5SYA 2043 Load - cycle capability of HiPaks
- 5SYA 2045 Thermal runaway during blocking
- 5SYA 2053 Applying IGBT
- 5SYA 2058 Surge currents for IGBT diodes
- 5SYA 2093 Thermal design of IGBT modules
- 5SYA 2098 Paralleling of IGBT modules
- 5SZK 9111 Specification of environmental class for HiPak Storage
- 5SZK 9112 Specification of environmental class for HiPak Transportation
- 5SZK 9113 Specification of environmental class for HiPak Operation (Industry)
- 5SZK 9120 Specification of environmental class for HiPak

We reserve all rights in this document and in the subject matter and illustrations contained therein. Any reproduction, disclosure to third parties or utilization of its contents - in whole or in parts - is forbidden without prior written consent. Copyright 2020 Hitachi Powergrids. All rights reserved.

## X-ON Electronics

Largest Supplier of Electrical and Electronic Components

*Click to view similar products for [IGBT Modules category](#):*

*Click to view products by [ABB manufacturer](#):*

Other Similar products are found below :

[F3L100R07W2E3\\_B11](#) [F3L400R07ME4\\_B22](#) [F4-50R07W2H3\\_B51](#) [FB15R06W1E3](#) [FB20R06W1E3\\_B11](#) [FD1000R33HE3-K](#)  
[FD400R12KE3](#) [FD400R33KF2C-K](#) [FD401R17KF6C\\_B2](#) [FD-DF80R12W1H3\\_B52](#) [FF200R06YE3](#) [FF450R12ME4P](#) [FF600R12IP4V](#)  
[FP06R12W1T4\\_B3](#) [FP10R06W1E3\\_B11](#) [FP15R12W2T4](#) [FP20R06W1E3](#) [FP75R07N2E4\\_B11](#) [FS10R12YE3](#) [FS150R07PE4](#) [FS150R12PT4](#)  
[FS20R06W1E3\\_B11](#) [FS50R07N2E4](#) [FS50R07N2E4\\_B11](#) [FZ1000R33HE3](#) [FZ1800R17KF4](#) [DD250S65K3](#) [DF1000R17IE4](#)  
[DF1000R17IE4D\\_B2](#) [DF1400R12IP4D](#) [DF200R12PT4\\_B6](#) [DF400R07PE4R\\_B6](#) [BSM75GB120DN2\\_E3223c-Se](#) [F3L300R12ME4\\_B22](#)  
[F3L75R07W2E3\\_B11](#) [F4-50R12KS4\\_B11](#) [FD1400R12IP4D](#) [FD200R12PT4\\_B6](#) [FD800R33KF2C-K](#) [FF150R12ME3G](#) [FF300R17KE3\\_S4](#)  
[FF300R17ME4\\_B11](#) [FF401R17KF6C\\_B2](#) [FF650R17IE4D\\_B2](#) [FF900R12IP4D](#) [FF900R12IP4DV](#) [FP30R06W1E3\\_B11](#) [FP50R07N2E4\\_B11](#)  
[FS100R07PE4](#) [FS150R07N3E4\\_B11](#)