

深 圳 市 雅 晶 鑫 有 限 公 司
Shenzhen Yajingxin Electron Co.,Ltd

SPECIFICATION FOR APPROVAL

CUSTOMER

NOMINAL FREQUENCY

8 ~ 50MHZ

HOLDER TYPE

SMD-5032-2PIN

SPEC. NO. (P/N)

CUSTOMER P/N

ISSUE DATE

Aug.3,2016

APPROVED	PREPARED	QA
APPROVED BY CUSTOMER :		AVL Status
Please return one copy with approval toHLC		

TYPE HF SEAM SEALED X'TAL

ELECTRICAL SPECIFICATIONS

HLC Parts Number :

Item	Symbol	Specifications				Notes
		Min	Type	Max	Units	
Nominal frequency	FO	8 ~ 50			MHz	
Mode of Oscillation	OT	Fundamental				
Load Capacitance	LC	20		pF		
Frequency Tolerance	FT	± 20		ppm	at 25 ± 3	
Frequency Stability		± 30		ppm	with working temperature Reference to 25	
Working temperature range	TR	-40~85				
Drive Level	DL	100		μ W		
Series Resonant Resistance RR	CI/RR			Ω	Max.	
Shunt Capacitance C0	C0	7		pF		
Aging		± 3		ppm/yr.		
Storage temperature range		-55 ~ 125				
Unit Weight				g		

Shenzhen Yajingxin Electron Co.,Ltd

Shenzhen Yajingxin Electron Co.,Ltd

MARKING

中性

Shenzhen Yajingxin Electron Co.,Ltd

TYPE HF SEAM SEALED X'TAL

RELIABILITY SPECIFICATIONS

NO.	TEST ITEM	TEST METHODS												
1	DROP TEST	Device are dropped from a height of 150 cm onto 2 mm thickness stainless plate executing 3 times of random drops.												
2	MECHANICAL SHOCK	Device are shocked to half sine wave (1000 G) three mutually perpendicular axes each 3 times.												
3	VIBRATION	<table border="0"> <tr> <td>Frequency range</td> <td>10 ~ 2000 Hz</td> </tr> <tr> <td>Amplitude</td> <td>1.5 mm</td> </tr> <tr> <td>Sweep Time</td> <td>20 minute</td> </tr> <tr> <td>Test Time</td> <td>2 hours</td> </tr> </table>	Frequency range	10 ~ 2000 Hz	Amplitude	1.5 mm	Sweep Time	20 minute	Test Time	2 hours				
Frequency range	10 ~ 2000 Hz													
Amplitude	1.5 mm													
Sweep Time	20 minute													
Test Time	2 hours													
4	SOLDERABILITY	<table border="0"> <tr> <td>MIL - STD - 20E Method 208C</td> <td></td> </tr> <tr> <td>Temperature</td> <td>245 ±5</td> </tr> <tr> <td>Material</td> <td>H63A (Silver 2 ~ 3 %)</td> </tr> <tr> <td>Immersion depth</td> <td>0.5 mm minimum</td> </tr> <tr> <td>Immersion time</td> <td>3 ± 0.5 seconds</td> </tr> <tr> <td>Flux</td> <td>Rosin resin methyl alcohol solvent (1 : 4)</td> </tr> </table>	MIL - STD - 20E Method 208C		Temperature	245 ±5	Material	H63A (Silver 2 ~ 3 %)	Immersion depth	0.5 mm minimum	Immersion time	3 ± 0.5 seconds	Flux	Rosin resin methyl alcohol solvent (1 : 4)
MIL - STD - 20E Method 208C														
Temperature	245 ±5													
Material	H63A (Silver 2 ~ 3 %)													
Immersion depth	0.5 mm minimum													
Immersion time	3 ± 0.5 seconds													
Flux	Rosin resin methyl alcohol solvent (1 : 4)													
5	RESISTANCE TO SOLDERING HEAT	MIL - SLD -202, Method 210, Condition I or J 10 sec immersion into 260 ± 5 solder pot, above 180 is 90 ~ 120 sec.												
6	LOW TEMP. STORAGE	Leave at - 55 ± 2 for 1000 ± 12 hours												
7	HIGH TEMP. STORAGE	Leave at 125 ± 2 for 1000 ± 12 hours												
8	THERMAL SHOCK	Total 100 cycles of the following temperature cycle												

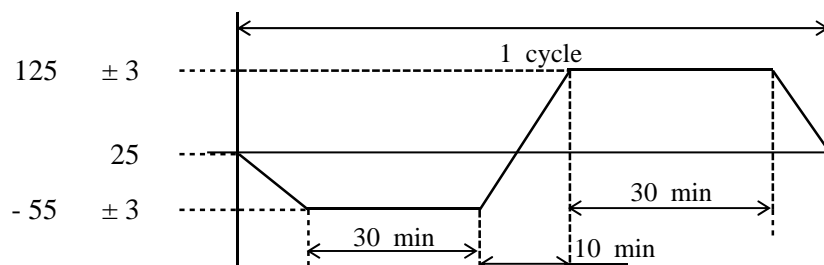

TYPE HF SEAM SEALED X'TAL

DIMENSIONS

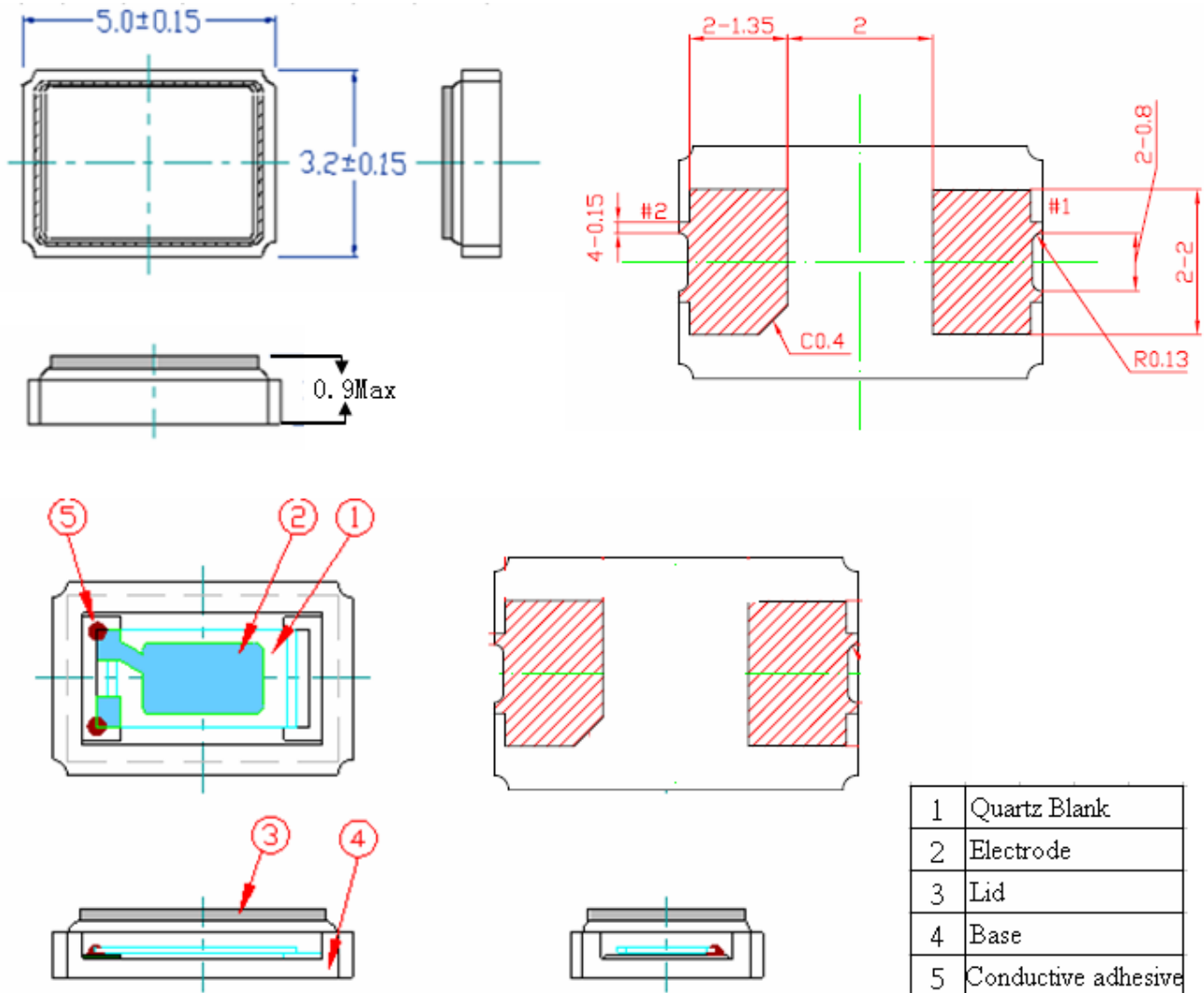

TYPE HF SEAM SEALED X'TAL

SUGGESTED IR REFLOW PROFILE

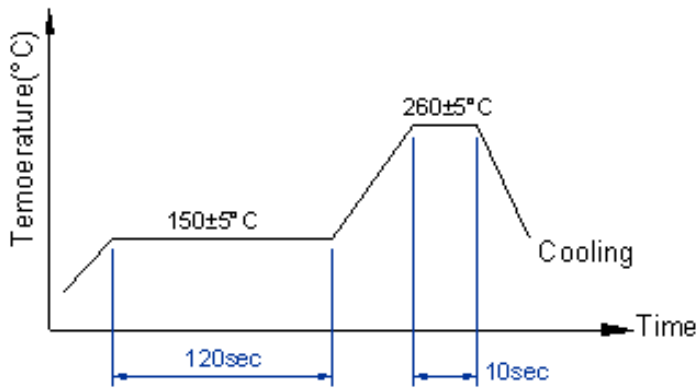

Total Time : 200 Sec.Max
Solder melting point : 185

PACKING

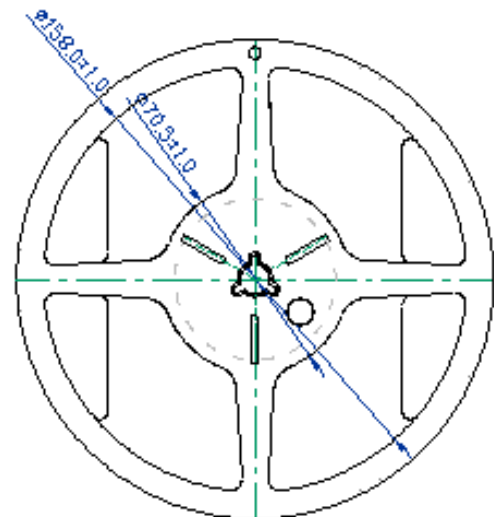
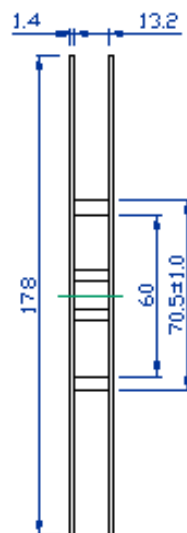
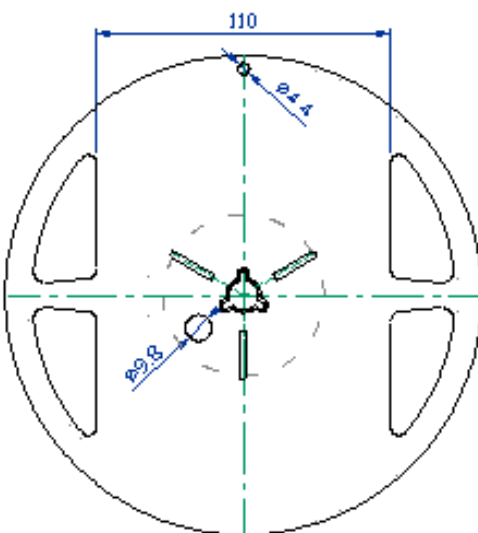
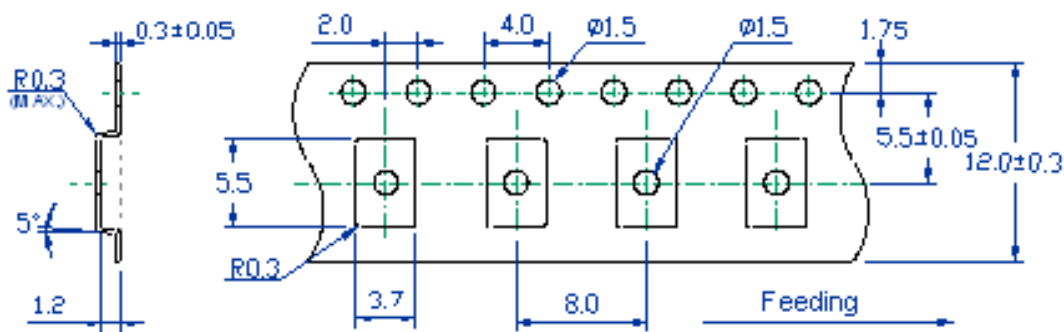

1. 230mm minimum leader which consist of carrier and/or tape followed by a minimum of 160mm of empty carrier tape sealed with cover tape.
2. 160mm minimum trailer of empty carrier tape sealed with cover tape.

Shenzhen Yajingxin Electron Co.,Ltd

TYPE HF SEAM SEALED X'TAL

PACKING

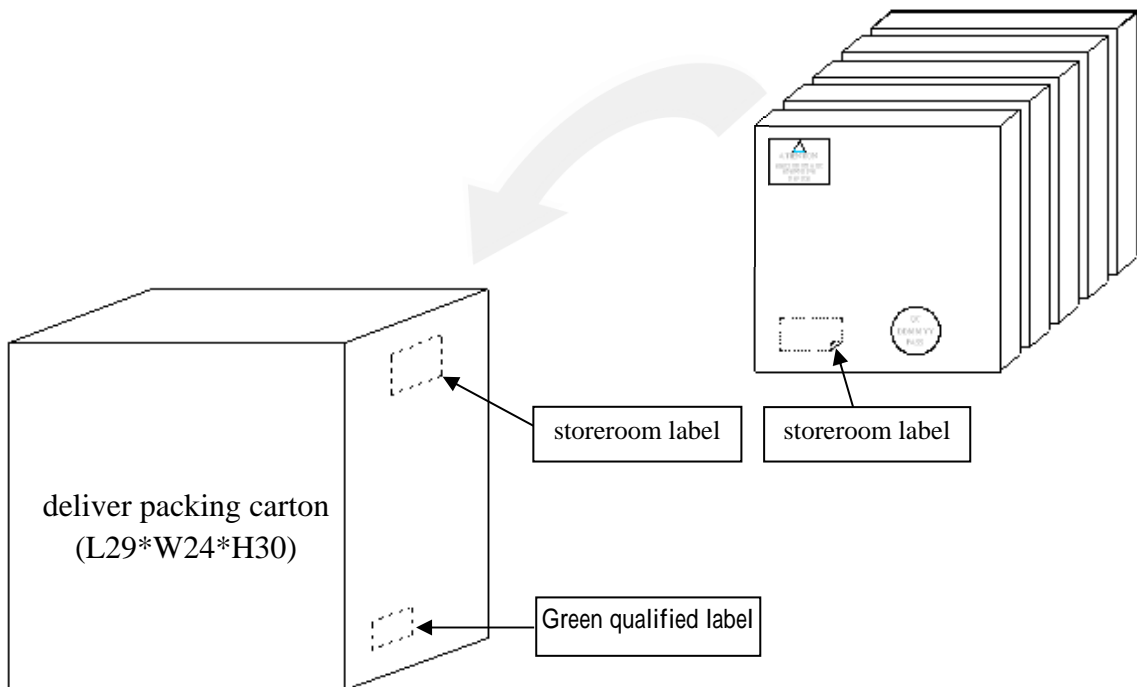
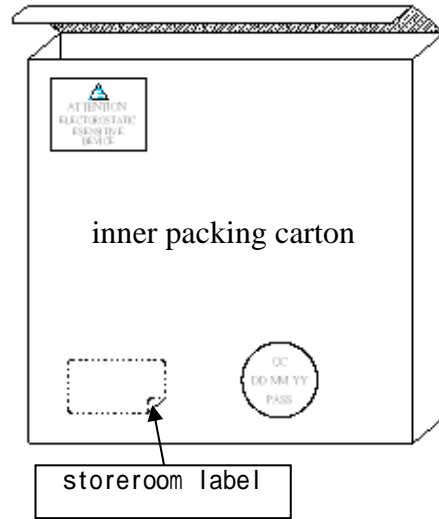
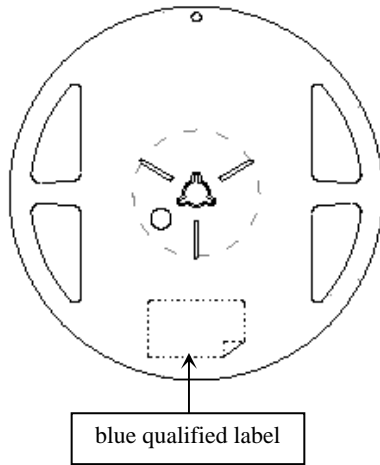
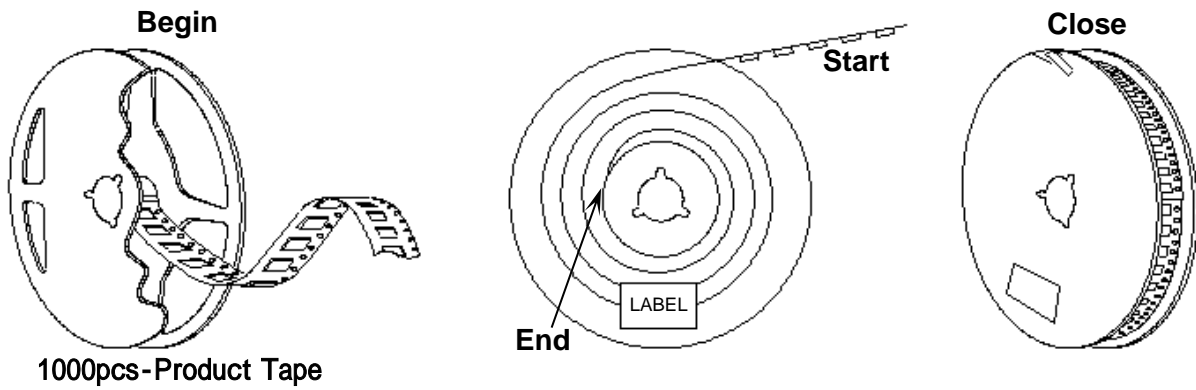

Shenzhen Yajingxin Electron Co.,Ltd

X-ON Electronics

Largest Supplier of Electrical and Electronic Components

Click to view similar products for [Crystals](#) category:

Click to view products by [Abel](#) manufacturer:

Other Similar products are found below :

[CS325S24000000ABJT](#) [718-13.2-1](#) [MC405 32.0000K-R3:PURE SN](#) [FC-135R 32.7680KF-A3](#) [7A-40.000MAAE-T](#) [7B-27.000MBBK-T](#)
[FL2000085](#) [9B-15.360MBBK-B](#) [9C-7.680MBBK-T](#) [ASH7K-32.768KHZ](#) [AT-41.600MAGQ-T](#) [BTD1062E05A-513](#) [LFX TAL066198Cutt](#)
[9C-14.31818MBBK-T](#) [FA-238 50.0000MB30X-K3](#) [FC-12M 32.7680KA-AC3](#) [SSPT7F-9PF20-R](#) [FX325BS-38.88EEM1201](#)
[LFX TAL065253Cutt](#) [LFX TAL066431Cutt](#) [XT9S20ANA14M7456](#) [XT9SNLANA16M](#) [646G-24-2](#) [7A-24.576MBBK-T](#) [7B-30.000MBBK-T](#)
[WX26-32.768K-6PF](#) [9B-14.31818MBBK-B](#) [CD1AM](#) [7B-25.000MAAE-T](#) [7A-14.31818MBBK-T](#) [6504-202-1501](#) [6526-202-1501](#) [FA-118T](#)
[27.1200MB50P-K0](#) [FC-135R 32.7680KA-A3](#) [ABM12-104-37.400MHZT](#) [ABLS-10.000MHZ-D3W-T](#) [BTJ112E01E-513](#) [BTJ722K01C-7067](#)
[BTL-20-513](#) [TSX-3225 24.0000MF15X-AC](#) [TSX-3225 16.0000MF18X-AC](#) [BTJ120E02C](#) [BTL-12-513](#) [7A-10.000MBBK-T](#) [7A-](#)
[11.0592MBBK-T](#) [ABM12-103-24.000MHZT](#) [CS325S25000000ABJT](#) [ABM3B-25.000MHZ-B2-X-T](#) [FC-135 32.7680KA-A5](#) [FX0800015](#)