

The S-75L00ANC is a single 2-input NAND gate fabricated by utilizing advanced silicon-gate CMOS technology which provides the inherent benefit of CMOS low power consumption to achieve operation by only a couple of batteries (1 to 3 V). The internal circuitry has buffered outputs to ensure high noise immunity and output stability.

Input voltage is allowed to be applied even if power voltage is not supplied because no diode is inserted between an input pin and  $V_{CC}$ .

This allows for interfaces between power supplies of different voltage, output level conversion from 3 V to 1 V and battery backup applications.

### ■ Features

- Wide power supply range: 1 V to 3.6 V
- Low current consumption: 1.0  $\mu$ A max. (at 3.6 V, 25°C)
- Typical propagation delay:  $t_{PD} = 7$  ns (at 3 V)
- High noise immunity:  $V_{NIH} = V_{NIL} = 28\%$   $V_{CC}$  min.
- Power down protection: All pins
- Lead-free

### ■ Applications

- Personal computers, peripherals
- Cellular phones
- Cameras
- Games

### ■ Package

- SC-88A

### ■ Pin Configuration

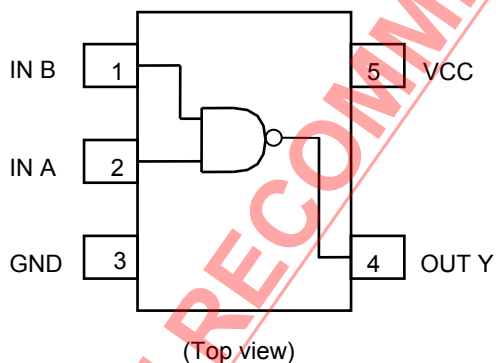

### ■ Marking Specification

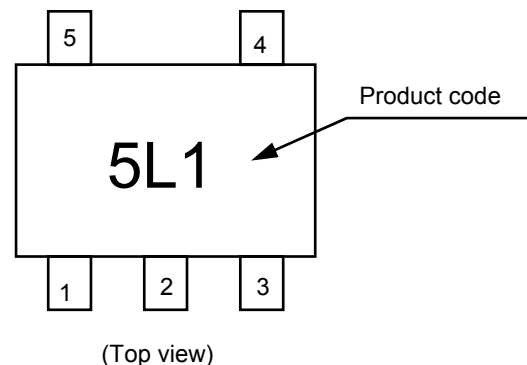

### ■ Logic Diagram

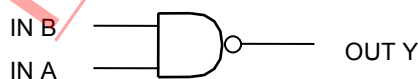

True values

A	B	Y
L	L	H
L	H	H
H	L	H
H	H	L

■ Product Name Structure

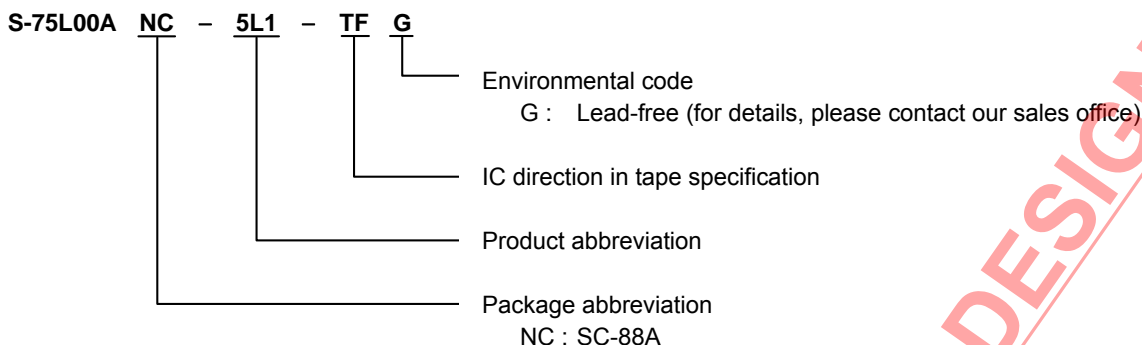

■ Absolute Maximum Ratings

(Ta = 25°C unless otherwise specified)

Item	Symbol	Absolute Maximum Ratings	Unit
Power supply voltage	$V_{CC}$	-0.5 to +5.0	V
Input voltage	$V_{IN}$	-0.5 to +5.0	V
Output voltage	$V_{OUT}$	-0.5 to $V_{CC} + 0.5$	V
Input parasitic diode current	$I_{IK}$	-20	mA
Output parasitic diode current	$I_{OK}$	±20	mA
Output current	$I_{OUT}$	±12.5	mA
$V_{CC}/GND$ current	$I_{CC}$	±25	mA
Power dissipation	$P_D$	200 (When not mounted on board)	mW
		350*1	mW
Operating ambient temperature	$T_{opr}$	-40 to +85	°C
Storage temperature	$T_{stg}$	-65 to +150	°C
Lead temperature (10 s)	$T_L$	260	°C

\*1. When mounted on board  
[Mounted board]

- (1) Board size : 114.3 mm × 76.2 mm × 1.6 mm
- (2) Board name : JEDEC STANDARD51-7

**Caution** The absolute maximum ratings are rated values exceeding which the product could suffer physical damage. These values must therefore not be exceeded under any conditions.

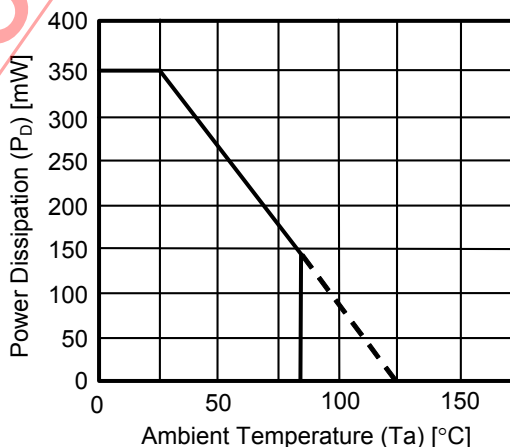

Power Dissipation of Package (When Mounted on Board)

### ■ Recommended Operating Conditions

Item	Symbol	Standard	Unit
Power voltage	$V_{CC}$	1 to 3.6	V
Input voltage	$V_{IN}$	0 to 3.6	V
Output voltage	$V_{OUT}$	0 to $V_{CC}$	V
Input rise / fall time	$t_R, t_F$	0 to 1000 ( $V_{CC} = 1.0$ V)	ns
		0 to 500 ( $V_{CC} = 2.0$ V)	ns
		0 to 400 ( $V_{CC} = 3.0$ V)	ns

### ■ DC Electrical Characteristics

Item	Symbol	Conditions	$T_a = 25^\circ\text{C}$			$T_a = -40$ to $85^\circ\text{C}$		Unit			
			$V_{CC}$	Min.	Typ.	Max.	Min.		Max.		
Input voltage	"H" level	$V_{IH}$	—	1.0	0.75	—	—	0.75	—	V	
				1.5	1.05	—	—	1.05	—	V	
				3.0	2.10	—	—	2.10	—	V	
	"L" level	$V_{IL}$	—	1.0	—	—	0.25	—	0.25	V	
				1.5	—	—	0.45	—	0.45	V	
				3.0	—	—	0.90	—	0.90	V	
Output voltage	"H" level	$V_{OH}$	$V_{IN} = V_{IH}$ or $V_{IL}$	$I_{OH} = -20 \mu\text{A}$	1.0	0.9	1.0	—	0.9	—	V
					1.5	1.4	1.5	—	1.4	—	V
					3.0	2.9	3.0	—	2.9	—	V
				$I_{OH} = -1 \text{ mA}$	1.5	1.07	1.23	—	0.99	—	V
					3.0	2.61	2.68	—	2.55	—	V
					3.0	2.61	2.68	—	2.55	—	V
	"L" level	$V_{OL}$	$V_{IN} = V_{IH}$	$I_{OL} = 20 \mu\text{A}$	1.0	—	0	0.1	—	0.1	V
					1.5	—	0	0.1	—	0.1	V
					3.0	—	0	0.1	—	0.1	V
				$I_{OL} = 1 \text{ mA}$	1.5	—	0.23	0.31	—	0.37	V
					3.0	—	0.23	0.31	—	0.33	V
					3.0	—	0.23	0.31	—	0.33	V
Input current	$I_{IN}$	$V_{IN} = V_{CC}$ or GND	3.6	—	—	$\pm 0.1$	—	$\pm 1.0$	$\mu\text{A}$		
Current consumption	$I_{CC}$	$V_{IN} = V_{CC}$ or GND	3.6	—	—	1.0	—	10.0	$\mu\text{A}$		

**■ AC Electrical Characteristics**

( $C_L = 15 \text{ pF}$ , Input  $t_R = t_F = 6 \text{ ns}$ ,  $V_{CC} = 3.3 \pm 0.3 \text{ V}$ ,  $T_a = 25^\circ\text{C}$  unless otherwise specified)

Item	Symbol	Measurement Conditions	Min.	Typ.	Max.	Unit
Output rise / fall time	$t_{TLH}$ , $t_{THL}$	—	—	4.0	8.5	ns
Propagation delay time	$t_{PLH}$ , $t_{PHL}$	—	—	6.0	9.0	ns

( $C_L = 25 \text{ pF}$ , Input  $t_R = t_F = 6 \text{ ns}$  unless otherwise specified)

Item	Symbol	Measurement Conditions	$T_a = 25^\circ\text{C}$			$T_a = -40 \text{ to } 85^\circ\text{C}$		Unit	
			$V_{CC} \text{ (V)}$	Min.	Typ.	Max.	Min.		Max.
Output rise / fall time	$t_{TLH}$ , $t_{THL}$	—	1.0	—	35	70	—	90	ns
			1.5	—	15	25	—	30	ns
			3.0	—	7	10	—	14	ns
Propagation delay time	$t_{PLH}$ , $t_{PHL}$	—	1.0	—	30	60	—	75	ns
			1.5	—	15	25	—	30	ns
			3.0	—	7	10	—	14	ns
Input capacitance	$C_{IN}$	—	—	5	10	—	10	pF	
Equivalent internal capacitance	$C_{PD}^{*1}$	—	—	10	—	—	—	pF	

\*1.  $C_{PD}$  is the no-load equivalent capacitance inside the circuitry. Refer to the measurement circuit shown below.  
 Current consumption is averaged by the following equation.

$$I_{CC(opr)} = C_{PD} \times V_{CC} \times fin + I_{CC}$$

**Measurement Circuit**

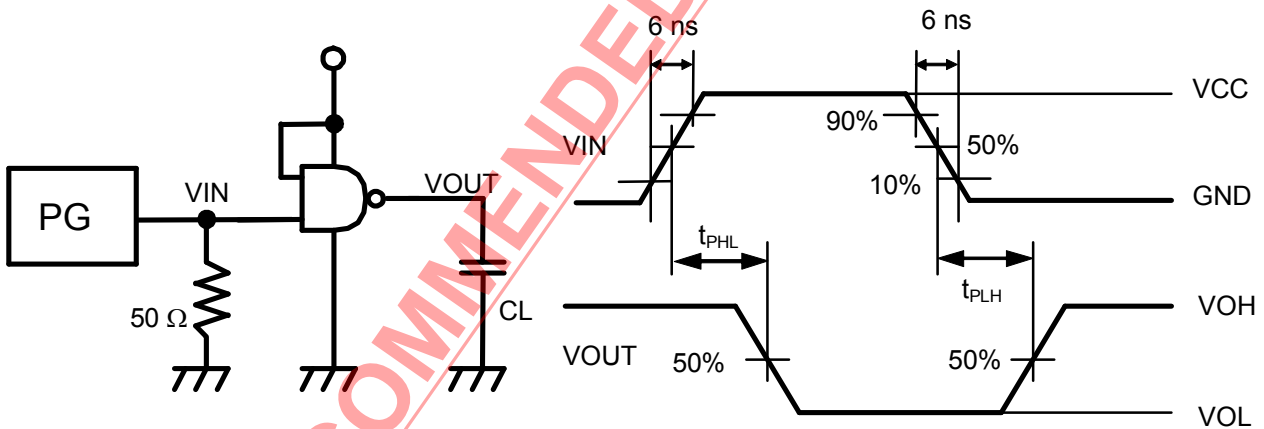

**Remark** No-load output during measurement of current consumption.

**■ Input Pin Equivalent Circuit**

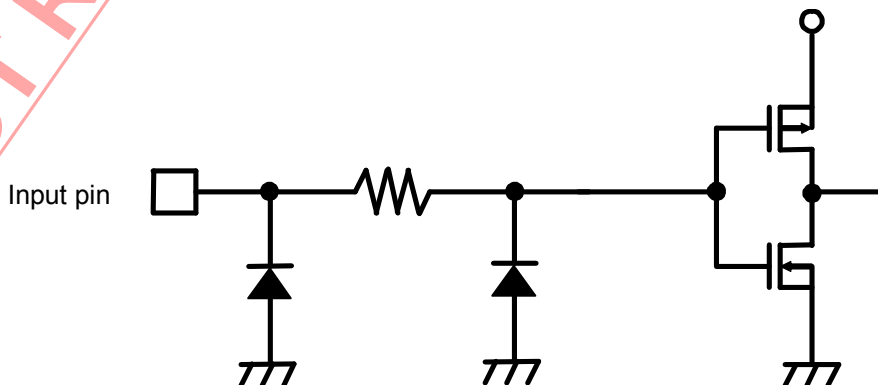

The S-75L02ANC is a single 2-input NOR gate fabricated by utilizing advanced silicon-gate CMOS technology which provides the inherent benefit of CMOS low power consumption to achieve operation by only a couple of batteries (1 to 3 V). The internal circuitry has buffered outputs to ensure high noise immunity and output stability.

Input voltage is allowed to be applied even if power voltage is not supplied because no diode is inserted between an input pin and  $V_{CC}$ .

This allows for interfaces between power supplies of different voltage, output level conversion from 3 V to 1 V and battery backup applications.

### ■ Features

- Wide power supply range: 1 V to 3.6 V
- Low current consumption: 1.0  $\mu$ A max. (at 3.6 V, 25°C)
- Typical propagation delay:  $t_{PD} = 7$  ns (at 3 V)
- High noise immunity:  $V_{NIH} = V_{NIL} = 28\% V_{CC}$  min.
- Power down protection: All pins
- Lead-free

### ■ Applications

- Personal computers, peripherals
- Cellular phones
- Cameras
- Games

### ■ Package

- SC-88A

### ■ Pin Configuration

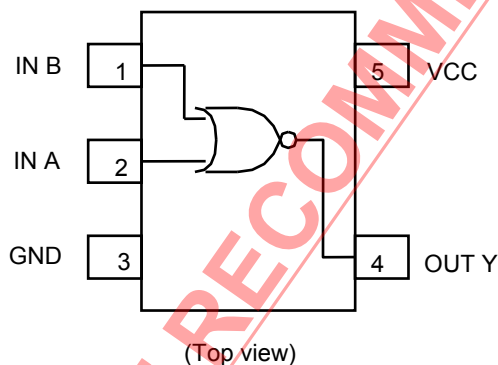

### ■ Marking Specification

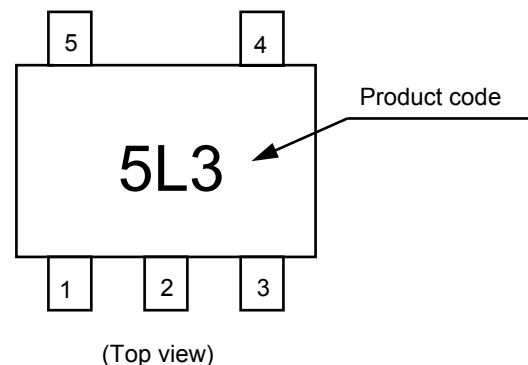

### ■ Logic Diagram

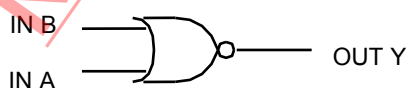

True values

A	B	Y
L	L	H
L	H	L
H	L	L
H	H	L

■ Product Name Structure

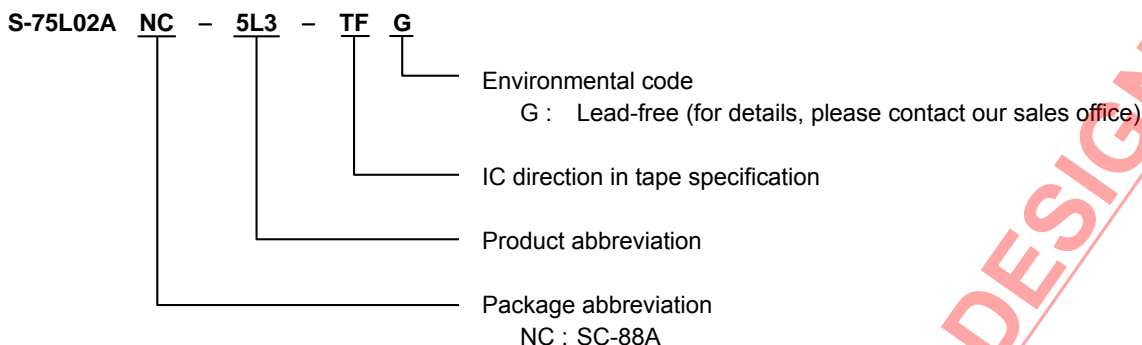

■ Absolute Maximum Ratings

(Ta = 25°C unless otherwise specified)

Item	Symbol	Absolute Maximum Ratings	Unit
Power supply voltage	$V_{CC}$	-0.5 to +5.0	V
Input voltage	$V_{IN}$	-0.5 to +5.0	V
Output voltage	$V_{OUT}$	-0.5 to $V_{CC} + 0.5$	V
Input parasitic diode current	$I_{IK}$	-20	mA
Output parasitic diode current	$I_{OK}$	±20	mA
Output current	$I_{OUT}$	±12.5	mA
$V_{CC}/GND$ current	$I_{CC}$	±25	mA
Power dissipation	$P_D$	200 (When not mounted on board)	mW
		350*1	mW
Operating ambient temperature	$T_{opr}$	-40 to +85	°C
Storage temperature	$T_{stg}$	-65 to +150	°C
Lead temperature (10 s)	$T_L$	260	°C

\*1. When mounted on board  
[Mounted board]

- (1) Board size : 114.3 mm × 76.2 mm × 1.6 mm
- (2) Board name : JEDEC STANDARD51-7

**Caution** The absolute maximum ratings are rated values exceeding which the product could suffer physical damage. These values must therefore not be exceeded under any conditions.

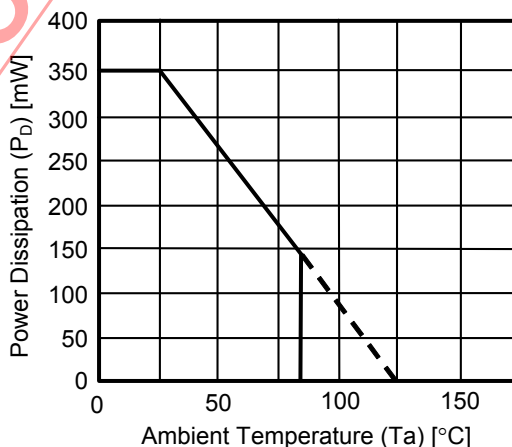

Power Dissipation of Package (When Mounted on Board)

### ■ Recommended Operating Conditions

Item	Symbol	Standard	Unit
Power voltage	$V_{CC}$	1 to 3.6	V
Input voltage	$V_{IN}$	0 to 3.6	V
Output voltage	$V_{OUT}$	0 to $V_{CC}$	V
Input rise / fall time	$t_R, t_F$	0 to 1000 ( $V_{CC} = 1.0$ V)	ns
		0 to 500 ( $V_{CC} = 2.0$ V)	ns
		0 to 400 ( $V_{CC} = 3.0$ V)	ns

### ■ DC Electrical Characteristics

Item	Symbol	Conditions	$T_a = 25^\circ\text{C}$			$T_a = -40$ to $85^\circ\text{C}$		Unit			
			$V_{CC}$	Min.	Typ.	Max.	Min.		Max.		
Input voltage	"H" level	$V_{IH}$	—	1.0	0.75	—	—	0.75	—	V	
				1.5	1.05	—	—	1.05	—	V	
				3.0	2.10	—	—	2.10	—	V	
	"L" level	$V_{IL}$	—	1.0	—	—	0.25	—	0.25	V	
				1.5	—	—	0.45	—	0.45	V	
				3.0	—	—	0.90	—	0.90	V	
Output voltage	"H" level	$V_{OH}$	$V_{IN} = V_{IL}$	$I_{OH} = -20 \mu\text{A}$	1.0	0.9	1.0	—	0.9	—	V
					1.5	1.4	1.5	—	1.4	—	V
					3.0	2.9	3.0	—	2.9	—	V
				$I_{OH} = -1 \text{ mA}$	1.5	1.07	1.23	—	0.99	—	V
					3.0	2.61	2.68	—	2.55	—	V
	"L" level	$V_{OL}$	$V_{IN} = V_{IL}$ or $V_{IH}$	$I_{OL} = 20 \mu\text{A}$	1.0	—	0	0.1	—	0.1	V
					1.5	—	0	0.1	—	0.1	V
					3.0	—	0	0.1	—	0.1	V
				$I_{OL} = 1 \text{ mA}$	1.5	—	0.23	0.31	—	0.37	V
					3.0	—	0.23	0.31	—	0.33	V
Input current	$I_{IN}$	$V_{IN} = V_{CC}$ or GND	3.6	—	—	$\pm 0.1$	—	$\pm 1.0$	$\mu\text{A}$		
Current consumption	$I_{CC}$	$V_{IN} = V_{CC}$ or GND	3.6	—	—	1.0	—	10.0	$\mu\text{A}$		

■ AC Electrical Characteristics

( $C_L = 15 \text{ pF}$ , Input  $t_R = t_F = 6 \text{ ns}$ ,  $V_{CC} = 3.3 \pm 0.3 \text{ V}$ ,  $T_a = 25^\circ\text{C}$  unless otherwise specified)

Item	Symbol	Measurement Conditions	Min.	Typ.	Max.	Unit
Output rise / fall time	$t_{TLH}$ , $t_{THL}$	—	—	4.0	8.0	ns
Propagation delay time	$t_{PLH}$ , $t_{PHL}$	—	—	6.0	9.0	ns

( $C_L = 25 \text{ pF}$ , Input  $t_R = t_F = 6 \text{ ns}$  unless otherwise specified)

Item	Symbol	Measurement Conditions	$T_a = 25^\circ\text{C}$			$T_a = -40 \text{ to } 85^\circ\text{C}$		Unit	
			$V_{CC} \text{ (V)}$	Min.	Typ.	Max.	Min.		Max.
Output rise / fall time	$t_{TLH}$ , $t_{THL}$	—	1.0	—	35	70	—	90	ns
			1.5	—	15	25	—	30	ns
			3.0	—	7	10	—	14	ns
Propagation delay time	$t_{PLH}$ , $t_{PHL}$	—	1.0	—	30	60	—	75	ns
			1.5	—	15	25	—	30	ns
			3.0	—	7	10	—	14	ns
Input capacitance	$C_{IN}$	—	—	5	10	—	10	pF	
Equivalent internal capacitance	$C_{PD}^{*1}$	—	—	10	—	—	—	pF	

\*1.  $C_{PD}$  is the no-load equivalent capacitance inside the circuitry. Refer to the measurement circuit shown below. Current consumption is averaged by the following equation.

$$I_{CC(opr)} = C_{PD} \times V_{CC} \times fin + I_{CC}$$

Measurement Circuit

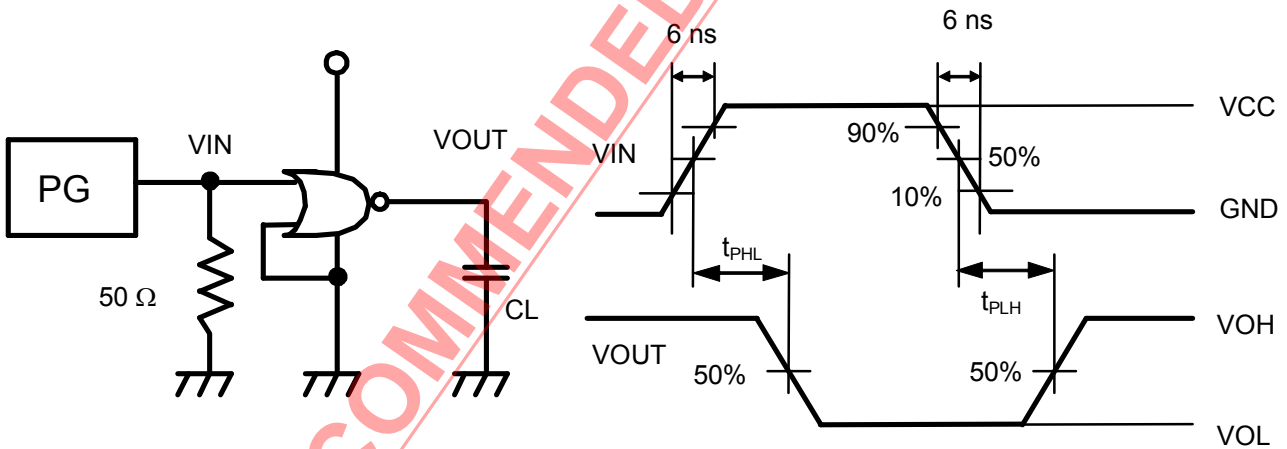

Remark No-load output during measurement of current consumption.

■ Input Pin Equivalent Circuit

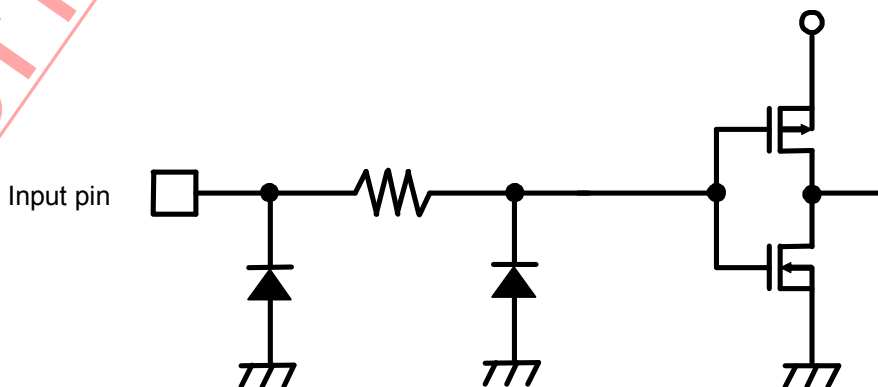



The S-75L04ANC is an inverter fabricated by utilizing advanced silicon-gate CMOS technology which provides the inherent benefit of CMOS low power consumption to achieve operation by only a couple of batteries (1 to 3 V). The internal circuitry has buffered outputs to ensure high noise immunity and output stability.

Input voltage is allowed to be applied even if power voltage is not supplied because no diode is inserted between an input pin and  $V_{CC}$ .

This allows for interfaces between power supplies of different voltage, output level conversion from 3 V to 1 V and battery backup applications.

### ■ Features

- Wide power supply range: 1 V to 3.6 V
- Low current consumption: 1.0  $\mu$ A max. (at 3.6 V, 25°C)
- Typical propagation delay:  $t_{PD} = 7$  ns (at 3 V)
- High noise immunity:  $V_{NIH} = V_{NIL} = 28\%$   $V_{CC}$  min.
- Power down protection: All pins
- Lead-free

### ■ Applications

- Personal computers, peripherals
- Cellular phones
- Cameras
- Games

### ■ Package

- SC-88A

### ■ Pin Configuration

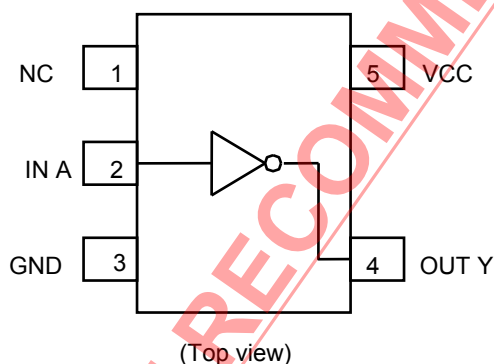

### ■ Marking Specification

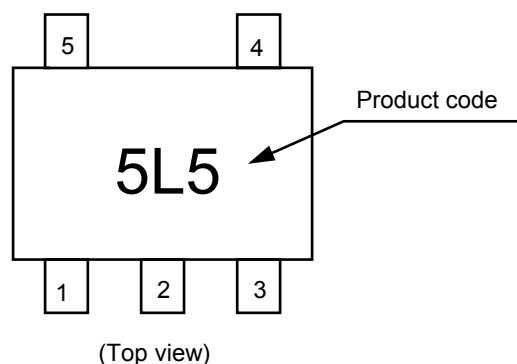

### ■ Logic Diagram

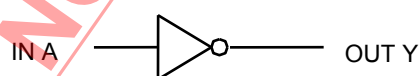

True values

A	Y
L	H
H	L

■ Product Name Structure

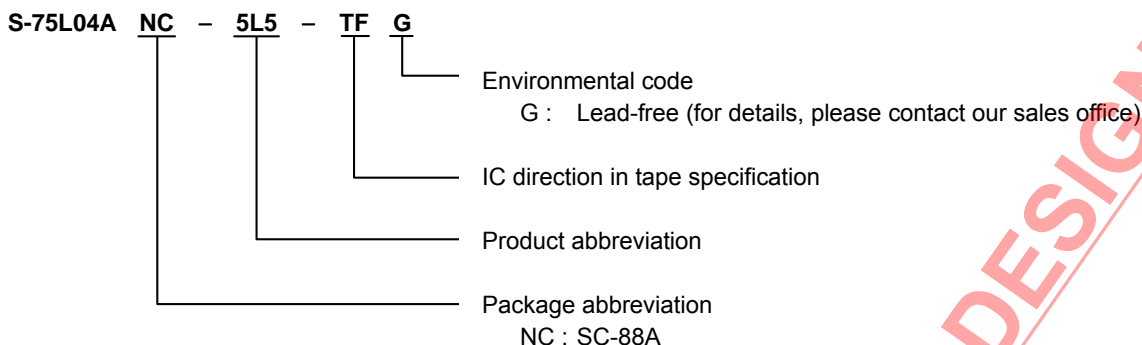

■ Absolute Maximum Ratings

(Ta = 25°C unless otherwise specified)

Item	Symbol	Absolute Maximum Ratings	Unit
Power supply voltage	$V_{CC}$	-0.5 to +5.0	V
Input voltage	$V_{IN}$	-0.5 to +5.0	V
Output voltage	$V_{OUT}$	-0.5 to $V_{CC} + 0.5$	V
Input parasitic diode current	$I_{IK}$	-20	mA
Output parasitic diode current	$I_{OK}$	$\pm 20$	mA
Output current	$I_{OUT}$	$\pm 12.5$	mA
$V_{CC}/GND$ current	$I_{CC}$	$\pm 25$	mA
Power dissipation	$P_D$	200 (When not mounted on board)	mW
		350 <sup>*1</sup>	mW
Operating ambient temperature	$T_{opr}$	-40 to +85	°C
Storage temperature	$T_{stg}$	-65 to +150	°C
Lead temperature (10 s)	$T_L$	260	°C

\*1. When mounted on board  
[Mounted board]

- (1) Board size : 114.3 mm × 76.2 mm × 1.6 mm
- (2) Board name : JEDEC STANDARD51-7

**Caution** The absolute maximum ratings are rated values exceeding which the product could suffer physical damage. These values must therefore not be exceeded under any conditions.

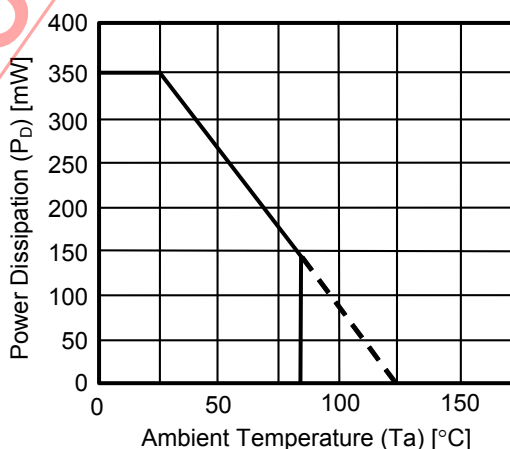

Power Dissipation of Package (When Mounted on Board)

### ■ Recommended Operating Conditions

Item	Symbol	Standard	Unit
Power voltage	$V_{CC}$	1 to 3.6	V
Input voltage	$V_{IN}$	0 to 3.6	V
Output voltage	$V_{OUT}$	0 to $V_{CC}$	V
Input rise / fall time	$t_R, t_F$	0 to 1000 ( $V_{CC} = 1.0$ V)	ns
		0 to 500 ( $V_{CC} = 2.0$ V)	ns
		0 to 400 ( $V_{CC} = 3.0$ V)	ns

### ■ DC Electrical Characteristics

Item	Symbol	Conditions	$T_a = 25^\circ\text{C}$			$T_a = -40$ to $85^\circ\text{C}$		Unit			
			$V_{CC}$	Min.	Typ.	Max.	Min.		Max.		
Input voltage	"H" level	$V_{IH}$	—	1.0	0.75	—	—	0.75	—	V	
				1.5	1.05	—	—	1.05	—	V	
				3.0	2.10	—	—	2.10	—	V	
	"L" level	$V_{IL}$	—	1.0	—	—	0.25	—	0.25	V	
				1.5	—	—	0.45	—	0.45	V	
				3.0	—	—	0.90	—	0.90	V	
Output voltage	"H" level	$V_{OH}$	$V_{IN} = V_{IL}$	$I_{OH} = -20 \mu\text{A}$	1.0	0.9	1.0	—	0.9	—	V
					1.5	1.4	1.5	—	1.4	—	V
					3.0	2.9	3.0	—	2.9	—	V
				$I_{OH} = -1 \text{ mA}$	1.5	1.07	1.23	—	0.99	—	V
					3.0	2.61	2.68	—	2.55	—	V
					3.0	2.61	2.68	—	2.55	—	V
	"L" level	$V_{OL}$	$V_{IN} = V_{IH}$	$I_{OL} = 20 \mu\text{A}$	1.0	—	0	0.1	—	0.1	V
					1.5	—	0	0.1	—	0.1	V
					3.0	—	0	0.1	—	0.1	V
				$I_{OL} = 1 \text{ mA}$	1.5	—	0.23	0.31	—	0.37	V
					3.0	—	0.23	0.31	—	0.33	V
					3.0	—	0.23	0.31	—	0.33	V
Input current	$I_{IN}$	$V_{IN} = V_{CC}$ or GND	3.6	—	—	$\pm 0.1$	—	$\pm 1.0$	$\mu\text{A}$		
Current consumption	$I_{CC}$	$V_{IN} = V_{CC}$ or GND	3.6	—	—	1.0	—	10.0	$\mu\text{A}$		

**■ AC Electrical Characteristics**

( $C_L = 15 \text{ pF}$ , Input  $t_R = t_F = 6 \text{ ns}$ ,  $V_{CC} = 3.3 \pm 0.3 \text{ V}$ ,  $T_a = 25^\circ\text{C}$  unless otherwise specified)

Item	Symbol	Measurement Conditions	Min.	Typ.	Max.	Unit
Output rise / fall time	$t_{TLH}$ , $t_{THL}$	—	—	4.0	8.0	ns
Propagation delay time	$t_{PLH}$ , $t_{PHL}$	—	—	6.0	9.0	ns

( $C_L = 25 \text{ pF}$ , Input  $t_R = t_F = 6 \text{ ns}$  unless otherwise specified)

Item	Symbol	Measurement Conditions	$T_a = 25^\circ\text{C}$			$T_a = -40 \text{ to } 85^\circ\text{C}$		Unit	
			$V_{CC} \text{ (V)}$	Min.	Typ.	Max.	Min.		Max.
Output rise / fall time	$t_{TLH}$ , $t_{THL}$	—	1.0	—	35	70	—	90	ns
			1.5	—	15	25	—	30	ns
			3.0	—	7	10	—	14	ns
Propagation delay time	$t_{PLH}$ , $t_{PHL}$	—	1.0	—	30	60	—	75	ns
			1.5	—	15	25	—	30	ns
			3.0	—	7	10	—	14	ns
Input capacitance	$C_{IN}$	—	—	5	10	—	10	pF	
Equivalent internal capacitance	$C_{PD}^{*1}$	—	—	10	—	—	—	pF	

\*1.  $C_{PD}$  is the no-load equivalent capacitance inside the circuitry. Refer to the measurement circuit shown below.  
Current consumption is averaged by the following equation.

$$I_{CC(opr)} = C_{PD} \times V_{CC} \times fin + I_{CC}$$

**Measurement Circuit**

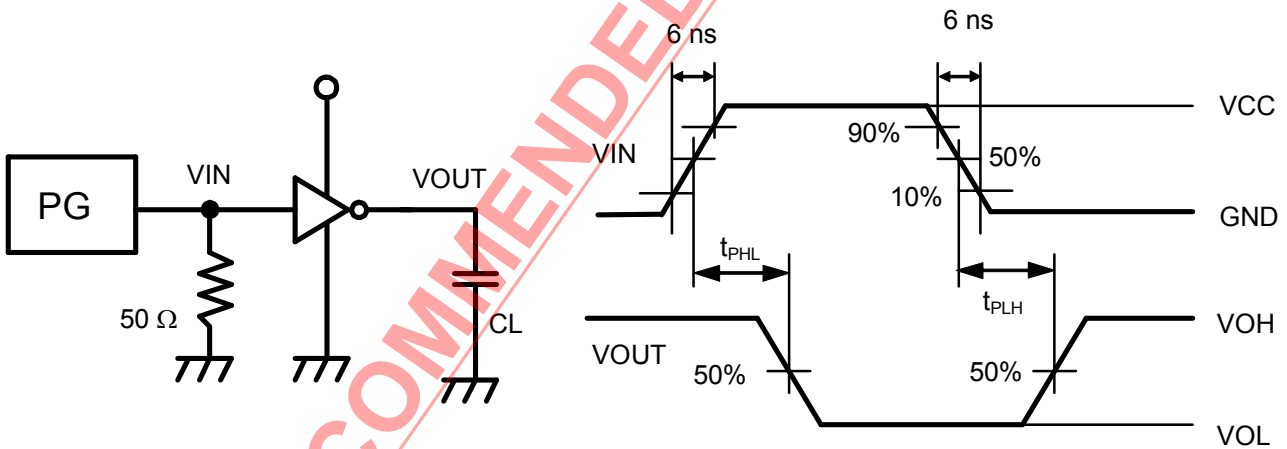

**Remark** No-load output during measurement of current consumption.

**■ Input Pin Equivalent Circuit**

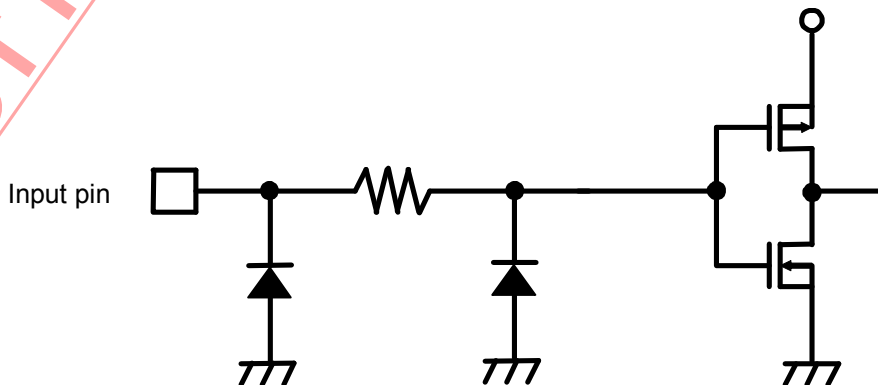

The S-75LU04ANC is a single packaged inverter without buffer fabricated by utilizing advanced silicon-gate CMOS technology which provides the inherent benefit of CMOS low power consumption to achieve operation by only a couple of batteries (1 to 3 V).

The S-75LU04ANC is suitable for a wide variety of linear circuits.

Input voltage is allowed to be applied even if power voltage is not supplied because no diode is inserted between an input pin and  $V_{CC}$ .

This allows for interfaces between power supplies of different voltage, output level conversion from 3 V to 1 V and battery backup applications.

### ■ Features

- Wide power supply range: 1 V to 3.6 V
- Low current consumption: 1.0  $\mu$ A max. (at 3.6 V, 25°C)
- Typical propagation delay:  $t_{PD} = 6$  ns (at 3 V)
- High noise immunity:  $V_{NIH} = V_{NIL} = 10\% V_{CC}$  min.
- Power down protection: All pins
- Lead-free

### ■ Applications

- Personal computers, peripherals
- Cellular phones
- Cameras
- Games

### ■ Package

- SC-88A

### ■ Pin Configuration

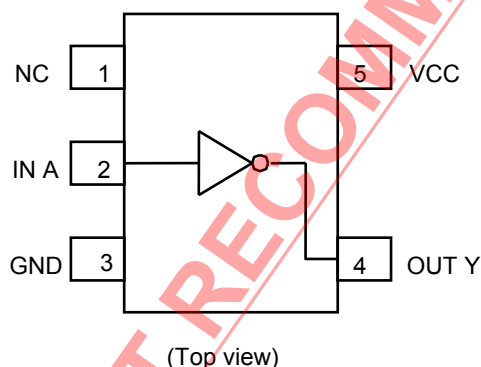

### ■ Marking Specification

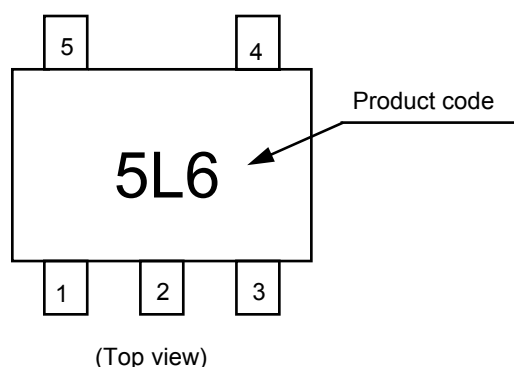

### ■ Logic Diagram

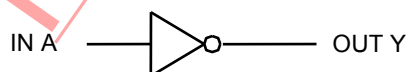

True values

A	Y
L	H
H	L

■ Product Name Structure

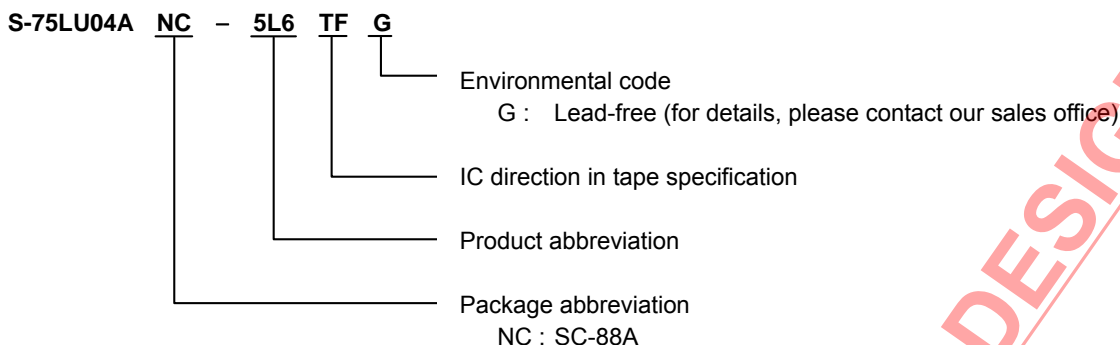

■ Absolute Maximum Ratings

(Ta = 25°C unless otherwise specified)

Item	Symbol	Absolute Maximum Ratings	Unit
Power supply voltage	$V_{CC}$	-0.5 to +5.0	V
Input voltage	$V_{IN}$	-0.5 to +5.0	V
Output voltage	$V_{OUT}$	-0.5 to $V_{CC} + 0.5$	V
Input parasitic diode current	$I_{IK}$	-20	mA
Output parasitic diode current	$I_{OK}$	±20	mA
Output current	$I_{OUT}$	±12.5	mA
$V_{CC}/GND$ current	$I_{CC}$	±25	mA
Power dissipation	$P_D$	200 (When not mounted on board) 350*1	mW
Operating ambient temperature	$T_{opr}$	-40 to +85	°C
Storage temperature	$T_{stg}$	-65 to +150	°C
Lead temperature (10 s)	$T_L$	260	°C

- \*1. When mounted on board  
[Mounted board]  
(1) Board size : 114.3 mm × 76.2 mm × 1.6 mm  
(2) Board name : JEDEC STANDARD51-7

**Caution** The absolute maximum ratings are rated values exceeding which the product could suffer physical damage. These values must therefore not be exceeded under any conditions.

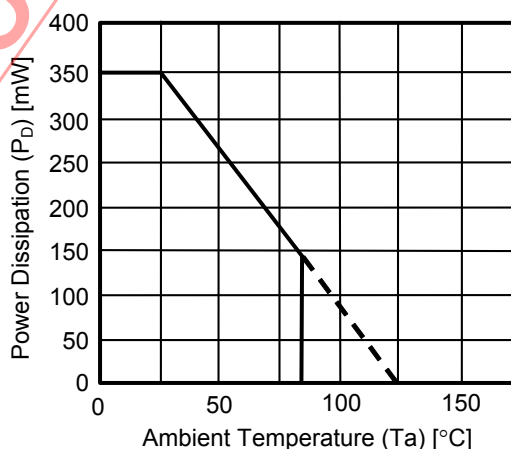

Power Dissipation of Package (When Mounted on Board)

### ■ Recommended Operating Conditions

Item	Symbol	Standard	Unit
Power voltage	$V_{CC}$	1 to 3.6	V
Input voltage	$V_{IN}$	0 to 3.6	V
Output voltage	$V_{OUT}$	0 to $V_{CC}$	V
Input rise / fall time	$t_R, t_F$	0 to 1000 ( $V_{CC} = 1.0$ V)	ns
		0 to 500 ( $V_{CC} = 2.0$ V)	ns
		0 to 400 ( $V_{CC} = 3.0$ V)	ns

### ■ DC Electrical Characteristics

Item	Symbol	Conditions	$T_a = 25^\circ\text{C}$			$T_a = -40$ to $85^\circ\text{C}$		Unit			
			$V_{CC}$	Min.	Typ.	Max.	Min.		Max.		
Input voltage	"H" level	$V_{IH}$	—	1.0	0.75	—	—	0.75	—	V	
				1.5	1.05	—	—	1.05	—	V	
				3.0	2.10	—	—	2.10	—	V	
	"L" level	$V_{IL}$	—	1.0	—	—	0.25	—	0.25	V	
				1.5	—	—	0.45	—	0.45	V	
				3.0	—	—	0.90	—	0.90	V	
Output voltage	"H" level	$V_{OH}$	$V_{IN} = V_{IL}$	$I_{OH} = -20 \mu\text{A}$	1.0	0.9	1.0	—	0.9	—	V
					1.5	1.4	1.5	—	1.4	—	V
					3.0	2.9	3.0	—	2.9	—	V
				$I_{OH} = -1 \text{ mA}$	1.5	1.07	1.23	—	0.99	—	V
					3.0	2.61	2.68	—	2.55	—	V
					3.0	2.61	2.68	—	2.55	—	V
	"L" level	$V_{OL}$	$V_{IN} = V_{IH}$	$I_{OL} = 20 \mu\text{A}$	1.0	—	0	0.1	—	0.1	V
					1.5	—	0	0.1	—	0.1	V
					3.0	—	0	0.1	—	0.1	V
				$I_{OL} = 1 \text{ mA}$	1.5	—	0.23	0.31	—	0.37	V
					3.0	—	0.23	0.31	—	0.33	V
					3.0	—	0.23	0.31	—	0.33	V
Input current	$I_{IN}$	$V_{IN} = V_{CC}$ or GND	3.6	—	—	$\pm 0.1$	—	$\pm 1.0$	$\mu\text{A}$		
Current consumption	$I_{CC}$	$V_{IN} = V_{CC}$ or GND	3.6	—	—	1.0	—	10.0	$\mu\text{A}$		

**■ AC Electrical Characteristics**

( $C_L = 15\text{ pF}$ , Input  $t_R = t_F = 6\text{ ns}$ ,  $V_{CC} = 3.3 \pm 0.3\text{ V}$ ,  $T_a = 25^\circ\text{C}$  unless otherwise specified)

Item	Symbol	Measurement Conditions	Min.	Typ.	Max.	Unit
Output rise / fall time	$t_{TLH}$ , $t_{THL}$	—	—	6.0	9.0	ns
Propagation delay time	$t_{PLH}$ , $t_{PHL}$	—	—	4.0	10.0	ns

( $C_L = 25\text{ pF}$ , Input  $t_R = t_F = 6\text{ ns}$  unless otherwise specified)

Item	Symbol	Measurement Conditions	$T_a = 25^\circ\text{C}$			$T_a = -40\text{ to }85^\circ\text{C}$		Unit	
			$V_{CC}\text{ (V)}$	Min.	Typ.	Max.	Min.		Max.
Output rise / fall time	$t_{TLH}$ , $t_{THL}$	—	1.0	—	35	70	—	90	ns
			1.5	—	15	25	—	30	ns
			3.0	—	7	10	—	14	ns
Propagation delay time	$t_{PLH}$ , $t_{PHL}$	—	1.0	—	20	40	—	50	ns
			1.5	—	10	15	—	20	ns
			3.0	—	6	9	—	12	ns
Input capacitance	$C_{IN}$	—	—	5	10	—	10	pF	
Equivalent internal capacitance	$C_{PD}^{*1}$	—	—	10	—	—	—	pF	

\*1.  $C_{PD}$  is the no-load equivalent capacitance inside the circuitry. Refer to the measurement circuit shown below. Current consumption is averaged by the following equation.

$$I_{CC(opr)} = C_{PD} \times V_{CC} \times fin + I_{CC}$$

**Measurement Circuit**

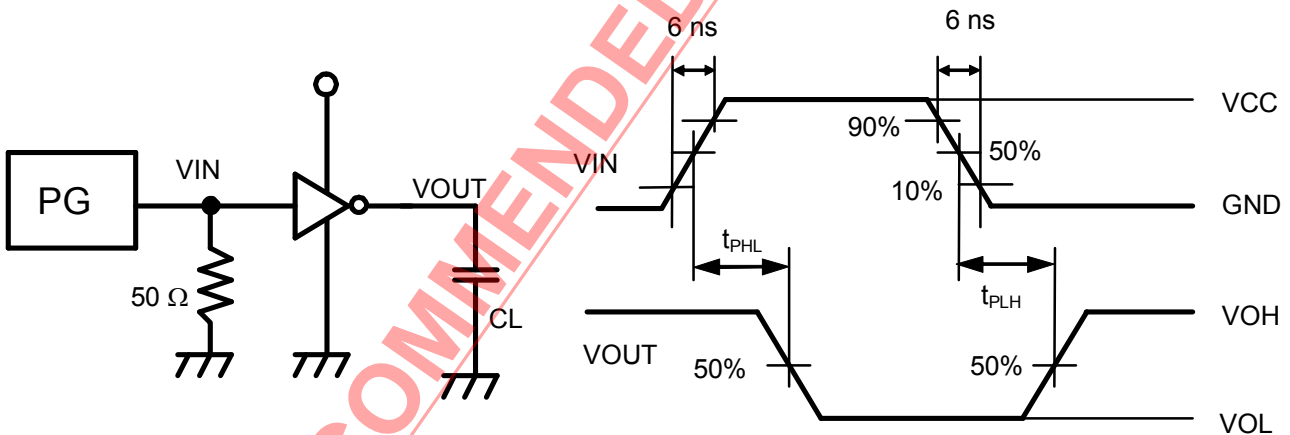

**Remark** No-load output during measurement of current consumption.

**■ Input Pin Equivalent Circuit**

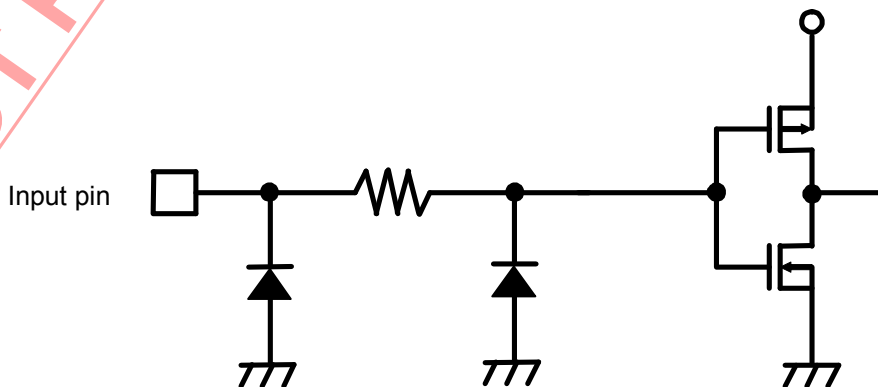



The S-75L08ANC is a single 2-Input AND Gate fabricated by utilizing advanced silicon-gate CMOS technology which provides the inherent benefit of CMOS low power consumption to achieve operation by only a couple of batteries (1 to 3 V). The internal circuitry has buffered outputs to ensure high noise immunity and output stability.

Input voltage is allowed to be applied even if power voltage is not supplied because no diode is inserted between an input pin and  $V_{CC}$ .

This allows for interfaces between power supplies of different voltage, output level conversion from 3 V to 1 V and battery backup applications.

### ■ Features

- Wide power supply range: 1 V to 3.6 V
- Low current consumption: 1.0  $\mu$ A max. (at 3.6 V, 25°C)
- Typical propagation delay:  $t_{PD} = 7$  ns (at 3 V)
- High noise immunity:  $V_{NIH} = V_{NIL} = 28\%$   $V_{CC}$  min.
- Power down protection: All pins
- Lead-free

### ■ Applications

- Personal computers, peripherals
- Cellular phones
- Cameras
- Games

### ■ Package

- SC-88A

### ■ Pin Configuration

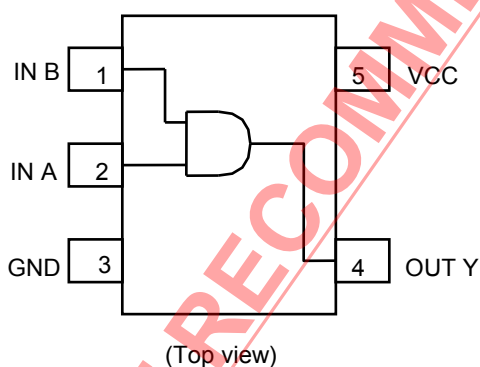

### ■ Marking Specification

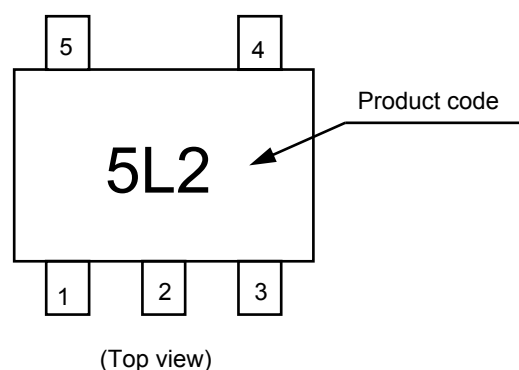

### ■ Logic Diagram

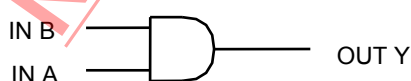

True values

A	B	Y
L	L	L
L	H	L
H	L	L
H	H	H

■ Product Name Structure

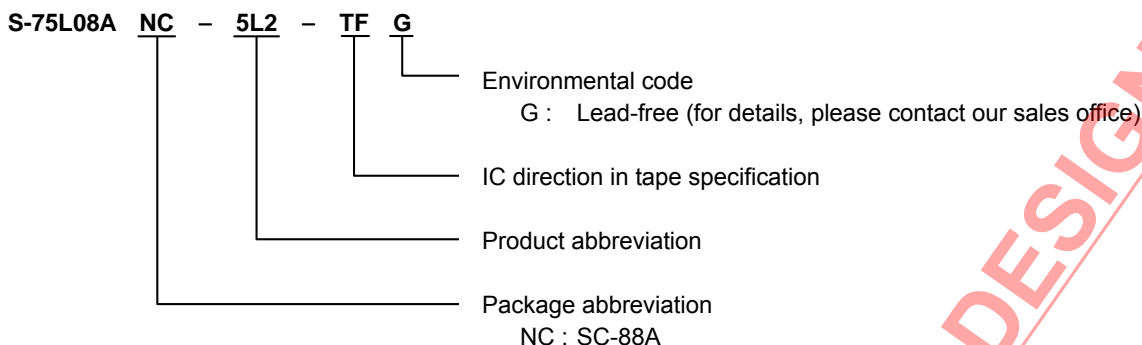

■ Absolute Maximum Ratings

(Ta = 25°C unless otherwise specified)

Item	Symbol	Absolute Maximum Ratings	Unit
Power supply voltage	$V_{CC}$	-0.5 to +5.0	V
Input voltage	$V_{IN}$	-0.5 to +5.0	V
Output voltage	$V_{OUT}$	-0.5 to $V_{CC} + 0.5$	V
Input parasitic diode current	$I_{IK}$	-20	mA
Output parasitic diode current	$I_{OK}$	±20	mA
Output current	$I_{OUT}$	±12.5	mA
$V_{CC}/GND$ current	$I_{CC}$	±25	mA
Power dissipation	$P_D$	200 (When not mounted on board)	mW
		350*1	mW
Operating ambient temperature	$T_{opr}$	-40 to +85	°C
Storage temperature	$T_{stg}$	-65 to +150	°C
Lead temperature (10 s)	$T_L$	260	°C

\*1. When mounted on board  
[Mounted board]

- (1) Board size : 114.3 mm × 76.2 mm × 1.6 mm
- (2) Board name : JEDEC STANDARD51-7

**Caution** The absolute maximum ratings are rated values exceeding which the product could suffer physical damage. These values must therefore not be exceeded under any conditions.

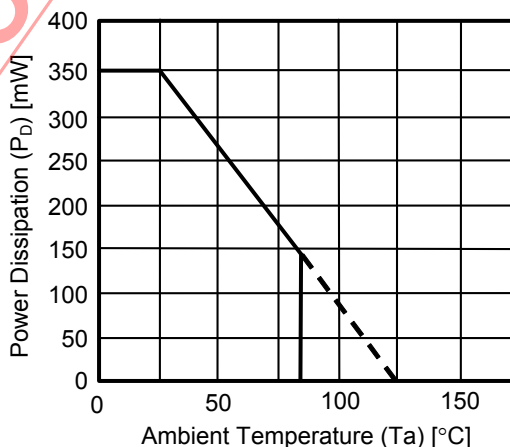

Power Dissipation of Package (When Mounted on Board)



■ AC Electrical Characteristics

( $C_L = 15 \text{ pF}$ , Input  $t_R = t_F = 6 \text{ ns}$ ,  $V_{CC} = 3.3 \pm 0.3 \text{ V}$ ,  $T_a = 25^\circ\text{C}$  unless otherwise specified)

Item	Symbol	Measurement Conditions	Min.	Typ.	Max.	Unit
Output rise / fall time	$t_{TLH}$ , $t_{THL}$	—	—	4.0	8.0	ns
Propagation delay time	$t_{PLH}$ , $t_{PHL}$	—	—	6.0	9.0	ns

( $C_L = 25 \text{ pF}$ , Input  $t_R = t_F = 6 \text{ ns}$  unless otherwise specified)

Item	Symbol	Measurement Conditions	$T_a = 25^\circ\text{C}$			$T_a = -40 \text{ to } 85^\circ\text{C}$		Unit	
			$V_{CC} \text{ (V)}$	Min.	Typ.	Max.	Min.		Max.
Output rise / fall time	$t_{TLH}$ , $t_{THL}$	—	1.0	—	35	70	—	90	ns
			1.5	—	15	25	—	30	ns
			3.0	—	7	10	—	14	ns
Propagation delay time	$t_{PLH}$ , $t_{PHL}$	—	1.0	—	30	60	—	75	ns
			1.5	—	15	25	—	30	ns
			3.0	—	7	10	—	14	ns
Input capacitance	$C_{IN}$	—	—	5	10	—	10	pF	
Equivalent internal capacitance	$C_{PD}^{*1}$	—	—	10	—	—	—	pF	

\*1.  $C_{PD}$  is the no-load equivalent capacitance inside the circuitry. Refer to the measurement circuit shown below. Current consumption is averaged by the following equation.

$$I_{CC(opr)} = C_{PD} \times V_{CC} \times fin + I_{CC}$$

Measurement Circuit

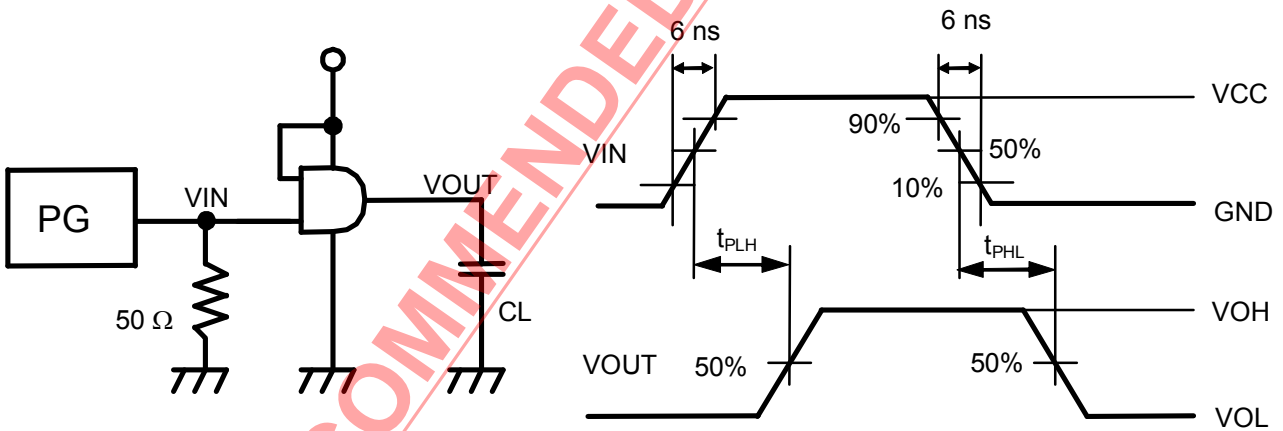

Remark No-load output during measurement of current consumption.

■ Input Pin Equivalent Circuit

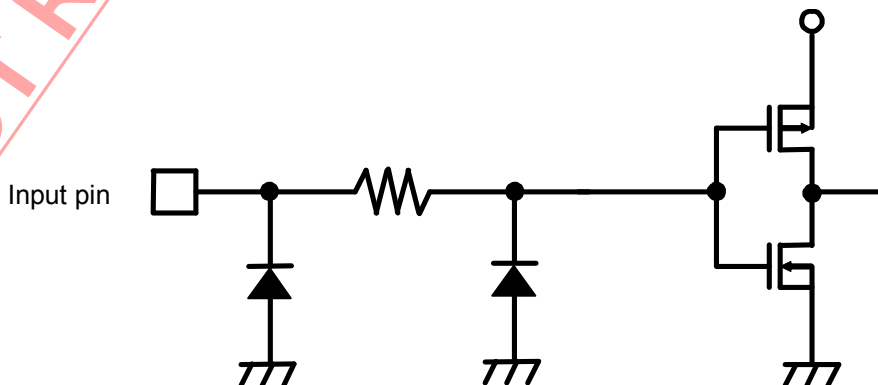

The S-75L14ANC is a SCHMITT INVERTER fabricated by utilizing advanced silicon-gate CMOS technology which provides the inherent benefit of CMOS low power consumption to achieve operation by only a couple of batteries (1 to 3 V).

The internal circuitry has buffered outputs to ensure high noise immunity and output stability.

Input voltage is allowed to be applied even if power voltage is not supplied because no diode is inserted between an input pin and  $V_{CC}$ .

This allows for interfaces between power supplies of different voltage, output level conversion from 3 V to 1 V and battery backup applications.

### ■ Features

- Wide power supply range: 1 V to 3.6 V
- Low current consumption: 1.0  $\mu$ A max. (at 3.6 V, 25°C)
- Typical propagation delay:  $t_{PD} = 8$  ns (at 3 V)
- High noise immunity:  $V_{NIH} = V_{NIL} = 28\% V_{CC}$  min.
- Power down protection: All pins
- Lead-free

### ■ Applications

- Personal computers, peripherals
- Cellular phones
- Cameras
- Games

### ■ Package

- SC-88A

### ■ Pin Configuration

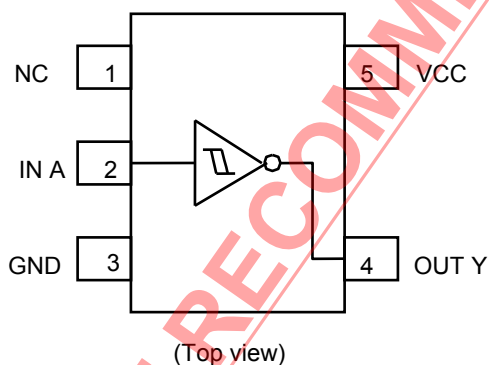

### ■ Marking Specification

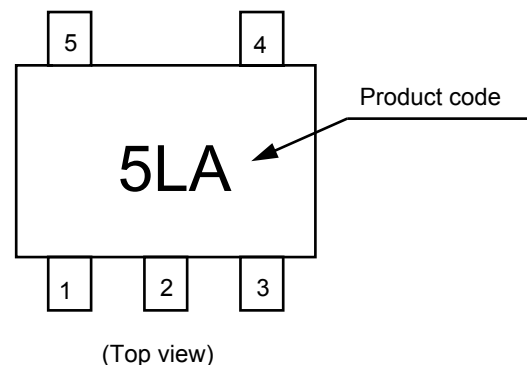

### ■ Logic Diagram

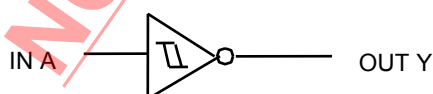

True values

A	Y
L	H
H	L

■ Product Name Structure

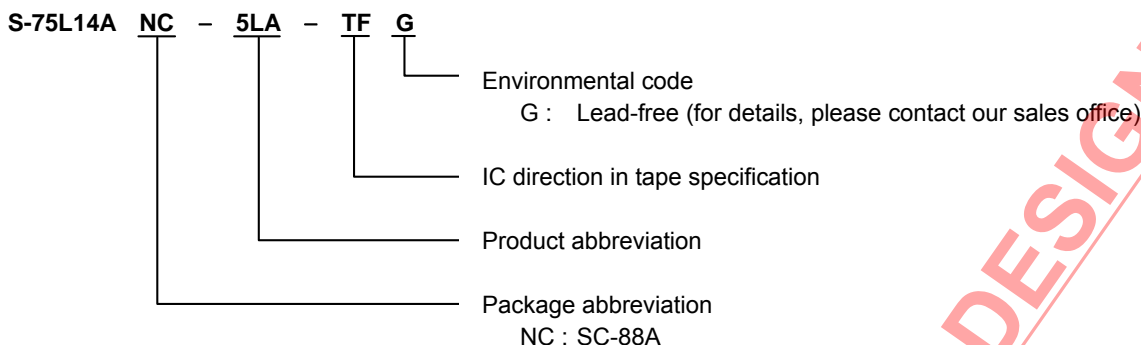

■ Absolute Maximum Ratings

(Ta = 25°C unless otherwise specified)

Item	Symbol	Absolute Maximum Ratings	Unit
Power supply voltage	$V_{CC}$	-0.5 to +5.0	V
Input voltage	$V_{IN}$	-0.5 to +5.0	V
Output voltage	$V_{OUT}$	-0.5 to $V_{CC} + 0.5$	V
Input parasitic diode current	$I_{IK}$	-20	mA
Output parasitic diode current	$I_{OK}$	±20	mA
Output current	$I_{OUT}$	±12.5	mA
$V_{CC}/GND$ current	$I_{CC}$	±25	mA
Power dissipation	$P_D$	200 (When not mounted on board)	mW
		350*1	mW
Operating ambient temperature	$T_{opr}$	-40 to +85	°C
Storage temperature	$T_{stg}$	-65 to +150	°C
Lead temperature (10 s)	$T_L$	260	°C

\*1. When mounted on board  
[Mounted board]

- (1) Board size : 114.3 mm × 76.2 mm × 1.6 mm
- (2) Board name : JEDEC STANDARD51-7

**Caution** The absolute maximum ratings are rated values exceeding which the product could suffer physical damage. These values must therefore not be exceeded under any conditions.

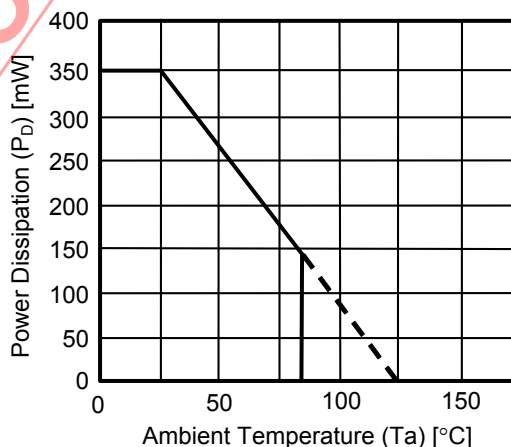

Power Dissipation of Package (When Mounted on Board)

### ■ Recommended Operating Conditions

Item	Symbol	Standard	Unit
Power voltage	$V_{CC}$	1 to 3.6	V
Input voltage	$V_{IN}$	0 to 3.6	V
Output voltage	$V_{OUT}$	0 to $V_{CC}$	V
Input rise / fall time	$t_R, t_F$	0 to 1000 ( $V_{CC} = 1.0$ V)	ns
		0 to 500 ( $V_{CC} = 2.0$ V)	ns
		0 to 400 ( $V_{CC} = 3.0$ V)	ns

### ■ DC Electrical Characteristics

Item	Symbol	Conditions	Ta = 25°C			Ta = -40 to 85°C		Unit				
			$V_{CC}$	Min.	Typ.	Max.	Min.		Max.			
Input voltage	"H" level	$V_{IH}$	—	1.0	0.80	—	—	0.80	—	V		
				1.5	1.20	—	—	1.20	—	V		
				3.0	2.10	—	—	2.10	—	V		
	"L" level	$V_{IL}$	—	1.0	—	—	0.20	—	0.20	V		
				1.5	—	—	0.45	—	0.45	V		
				3.0	—	—	0.90	—	0.90	V		
Output voltage	"H" level	$V_{OH}$	$V_{IN} = V_{IL}$	$I_{OH} = -20 \mu A$	1.0	0.9	1.0	—	0.9	—	V	
					1.5	1.4	1.5	—	1.4	—	V	
					3.0	2.9	3.0	—	2.9	—	V	
				$I_{OH} = -1$ mA	1.5	1.07	1.23	—	0.99	—	V	
					3.0	$I_{OH} = -2.6$ mA	2.61	2.68	—	2.55	—	V
						—	—	—	—	—	—	V
	"L" level	$V_{OL}$	$V_{IN} = V_{IH}$	$I_{OL} = 20 \mu A$	1.0	—	0	0.1	—	0.1	V	
					1.5	—	0	0.1	—	0.1	V	
					3.0	—	0	0.1	—	0.1	V	
				$I_{OL} = 1$ mA	1.5	—	0.23	0.31	—	0.37	V	
					3.0	$I_{OL} = 2.6$ mA	0.23	0.31	—	0.33	V	
						—	—	—	—	—	—	V
Hysteresis Voltage	$V_H$	—	—	1.0	0.20	—	0.50	—	—	V		
				1.5	0.25	—	0.50	—	—	V		
				3.0	0.45	—	0.65	—	—	V		
Input current	$I_{IN}$	$V_{IN} = V_{CC}$ or GND	3.6	—	—	$\pm 0.1$	—	$\pm 1.0$	$\mu A$			
Current consumption	$I_{CC}$	$V_{IN} = V_{CC}$ or GND	3.6	—	—	1.0	—	10.0	$\mu A$			

**■ AC Electrical Characteristics**

( $C_L = 15\text{ pF}$ , Input  $t_R = t_F = 6\text{ ns}$ ,  $V_{CC} = 3.3 \pm 0.3\text{ V}$ ,  $T_a = 25^\circ\text{C}$  unless otherwise specified)

Item	Symbol	Measurement Conditions	Min.	Typ.	Max.	Unit
Output rise / fall time	$t_{TLH}$ , $t_{THL}$	—	—	4.0	8.0	ns
Propagation delay time	$t_{PLH}$ , $t_{PHL}$	—	—	4.0	10.5	ns

( $C_L = 25\text{ pF}$ , Input  $t_R = t_F = 6\text{ ns}$  unless otherwise specified)

Item	Symbol	Measurement Conditions	$T_a = 25^\circ\text{C}$			$T_a = -40\text{ to }85^\circ\text{C}$		Unit	
			$V_{CC}\text{ (V)}$	Min.	Typ.	Max.	Min.		Max.
Output rise / fall time	$t_{TLH}$ , $t_{THL}$	—	1.0	—	35	70	—	90	ns
			1.5	—	15	25	—	30	ns
			3.0	—	7	10	—	14	ns
Propagation delay time	$t_{PLH}$ , $t_{PHL}$	—	1.0	—	35	70	—	90	ns
			1.5	—	15	25	—	30	ns
			3.0	—	8	12	—	15	ns
Input capacitance	$C_{IN}$	—	—	5	10	—	10	pF	
Equivalent internal capacitance	$C_{PD}^{*1}$	—	—	10	—	—	—	pF	

\*1.  $C_{PD}$  is the no-load equivalent capacitance inside the circuitry. Refer to the measurement circuit shown below.  
 Current consumption is averaged by the following equation.

$$I_{CC(opr)} = C_{PD} \times V_{CC} \times fin + I_{CC}$$

**Measurement Circuit**

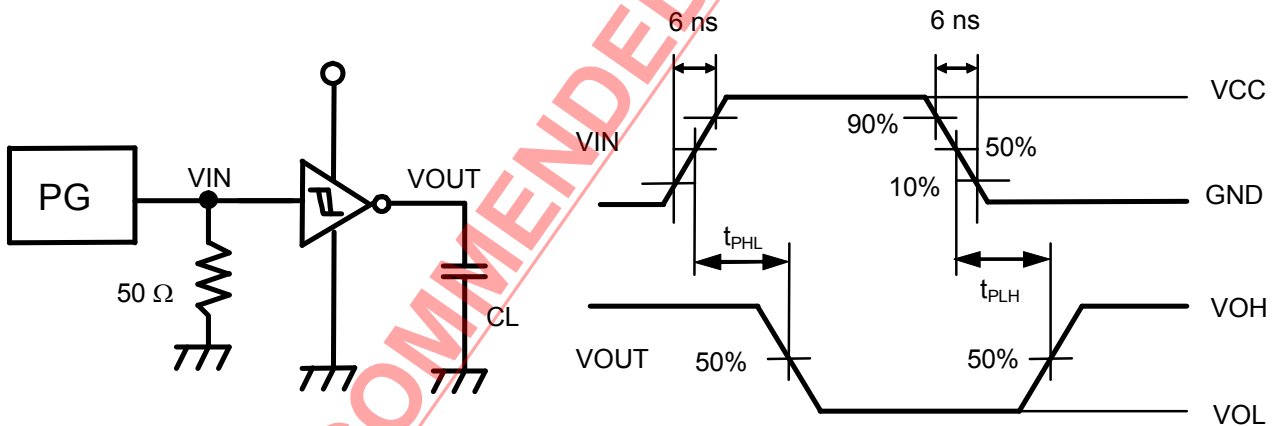

**Remark** No-load output during measurement of current consumption.

**■ Input Pin Equivalent Circuit**

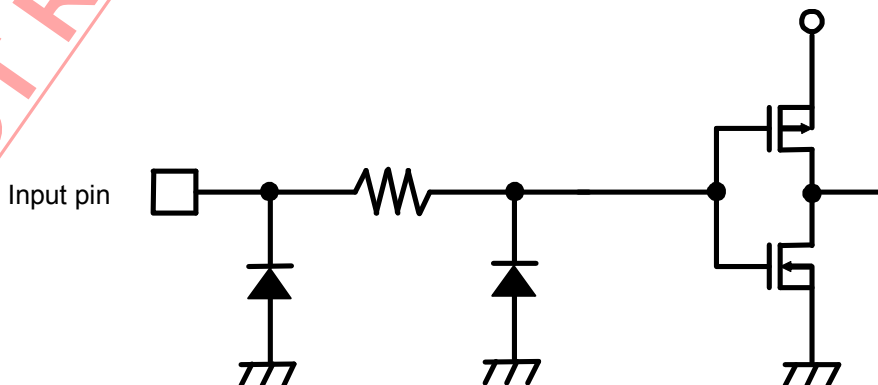



The S-75L32ANC is a single 2-input OR gate fabricated by utilizing advanced silicon-gate CMOS technology which provides the inherent benefit of CMOS low power consumption to achieve operation by only a couple of batteries (1 to 3 V).

The internal circuitry has buffered outputs to ensure high noise immunity and output stability.

Input voltage is allowed to be applied even if power voltage is not supplied because no diode is inserted between an input pin and  $V_{CC}$ .

This allows for interfaces between power supplies of different voltage, output level conversion from 3 V to 1 V and battery backup applications.

### ■ Features

- Wide power supply range: 1 V to 3.6 V
- Low current consumption: 1.0  $\mu$ A max. (at 3.6 V, 25°C)
- Typical propagation delay:  $t_{PD} = 7$  ns (at 3 V)
- High noise immunity:  $V_{NIH} = V_{NIL} = 28\% V_{CC}$  min.
- Power down protection: All pins
- Lead-free

### ■ Applications

- Personal computers, peripherals
- Cellular phones
- Cameras
- Games

### ■ Package

- SC-88A

### ■ Pin Configuration

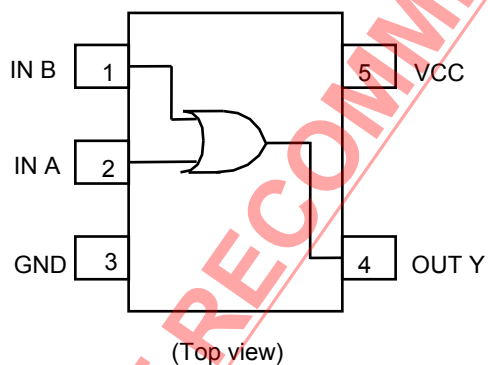

### ■ Marking Specification

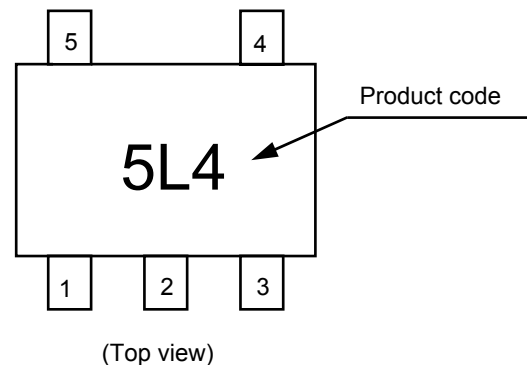

### ■ Logic Diagram

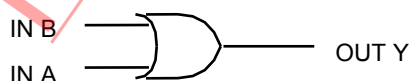

True values

A	B	Y
L	L	L
L	H	H
H	L	H
H	H	H

■ Product Name Structure

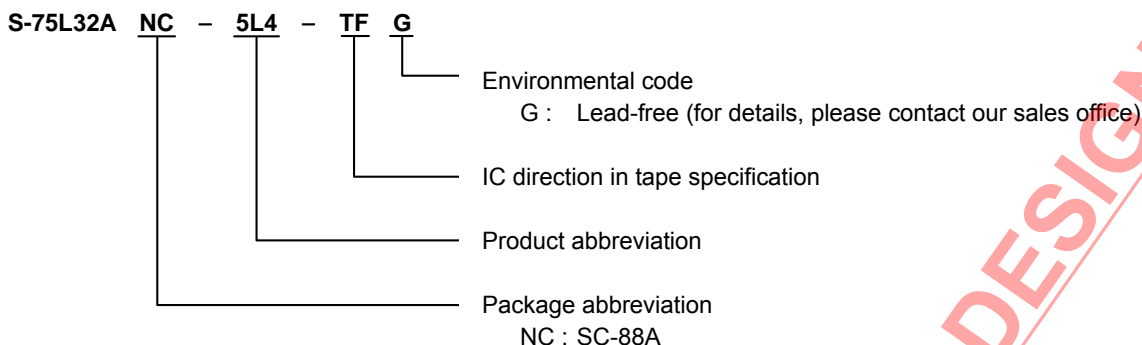

■ Absolute Maximum Ratings

(Ta = 25°C unless otherwise specified)

Item	Symbol	Absolute Maximum Ratings	Unit
Power supply voltage	$V_{CC}$	-0.5 to +5.0	V
Input voltage	$V_{IN}$	-0.5 to +5.0	V
Output voltage	$V_{OUT}$	-0.5 to $V_{CC} + 0.5$	V
Input parasitic diode current	$I_{IK}$	-20	mA
Output parasitic diode current	$I_{OK}$	±20	mA
Output current	$I_{OUT}$	±12.5	mA
$V_{CC}/GND$ current	$I_{CC}$	±25	mA
Power dissipation	$P_D$	200 (When not mounted on board)	mW
		350*1	mW
Operating ambient temperature	$T_{opr}$	-40 to +85	°C
Storage temperature	$T_{stg}$	-65 to +150	°C
Lead temperature (10 s)	$T_L$	260	°C

\*1. When mounted on board  
[Mounted board]

- (1) Board size : 114.3 mm × 76.2 mm × 1.6 mm
- (2) Board name : JEDEC STANDARD51-7

**Caution** The absolute maximum ratings are rated values exceeding which the product could suffer physical damage. These values must therefore not be exceeded under any conditions.

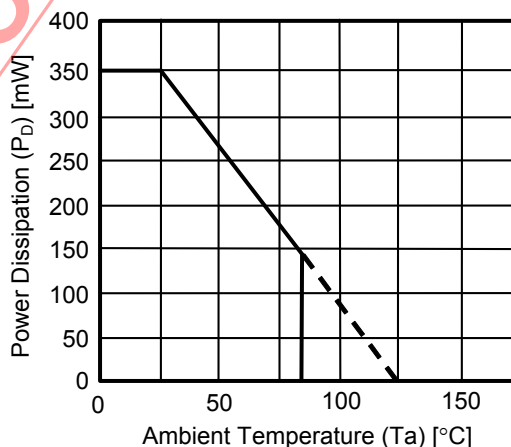

Power Dissipation of Package (When Mounted on Board)

### ■ Recommended Operating Conditions

Item	Symbol	Standard	Unit
Power voltage	$V_{CC}$	1 to 3.6	V
Input voltage	$V_{IN}$	0 to 3.6	V
Output voltage	$V_{OUT}$	0 to $V_{CC}$	V
Input rise / fall time	$t_R, t_F$	0 to 1000 ( $V_{CC} = 1.0$ V)	ns
		0 to 500 ( $V_{CC} = 2.0$ V)	ns
		0 to 400 ( $V_{CC} = 3.0$ V)	ns

### ■ DC Electrical Characteristics

Item	Symbol	Conditions	$T_a = 25^\circ\text{C}$			$T_a = -40$ to $85^\circ\text{C}$		Unit			
			$V_{CC}$	Min.	Typ.	Max.	Min.		Max.		
Input voltage	"H" level	$V_{IH}$	—	1.0	0.75	—	—	0.75	—	V	
				1.5	1.05	—	—	1.05	—	V	
				3.0	2.10	—	—	2.10	—	V	
	"L" level	$V_{IL}$	—	1.0	—	—	0.25	—	0.25	V	
				1.5	—	—	0.45	—	0.45	V	
				3.0	—	—	0.90	—	0.90	V	
Output voltage	"H" level	$V_{OH}$	$V_{IN} = V_{IH}$ or $V_{IL}$	$I_{OH} = -20 \mu\text{A}$	1.0	0.9	1.0	—	0.9	—	V
					1.5	1.4	1.5	—	1.4	—	V
					3.0	2.9	3.0	—	2.9	—	V
				$I_{OH} = -1 \text{ mA}$	1.5	1.07	1.23	—	0.99	—	V
					3.0	2.61	2.68	—	2.55	—	V
					3.0	2.61	2.68	—	2.55	—	V
	"L" level	$V_{OL}$	$V_{IN} = V_{IL}$	$I_{OL} = 20 \mu\text{A}$	1.0	—	0	0.1	—	0.1	V
					1.5	—	0	0.1	—	0.1	V
					3.0	—	0	0.1	—	0.1	V
				$I_{OL} = 1 \text{ mA}$	1.5	—	0.23	0.31	—	0.37	V
					3.0	—	0.23	0.31	—	0.33	V
					3.0	—	0.23	0.31	—	0.33	V
Input current	$I_{IN}$	$V_{IN} = V_{CC}$ or GND	3.6	—	—	$\pm 0.1$	—	$\pm 1.0$	$\mu\text{A}$		
Current consumption	$I_{CC}$	$V_{IN} = V_{CC}$ or GND	3.6	—	—	1.0	—	10.0	$\mu\text{A}$		

■ AC Electrical Characteristics

( $C_L = 15\text{ pF}$ , Input  $t_R = t_F = 6\text{ ns}$ ,  $V_{CC} = 3.3 \pm 0.3\text{ V}$ ,  $T_a = 25^\circ\text{C}$  unless otherwise specified)

Item	Symbol	Measurement Conditions	Min.	Typ.	Max.	Unit
Output rise / fall time	$t_{TLH}$ , $t_{THL}$	—	—	4.0	8.0	ns
Propagation delay time	$t_{PLH}$ , $t_{PHL}$	—	—	6.0	9.0	ns

( $C_L = 25\text{ pF}$ , Input  $t_R = t_F = 6\text{ ns}$  unless otherwise specified)

Item	Symbol	Measurement Conditions	$T_a = 25^\circ\text{C}$			$T_a = -40\text{ to }85^\circ\text{C}$		Unit	
			$V_{CC}\text{ (V)}$	Min.	Typ.	Max.	Min.		Max.
Output rise / fall time	$t_{TLH}$ , $t_{THL}$	—	1.0	—	35	70	—	90	ns
			1.5	—	15	25	—	30	ns
			3.0	—	7	10	—	14	ns
Propagation delay time	$t_{PLH}$ , $t_{PHL}$	—	1.0	—	30	60	—	75	ns
			1.5	—	15	25	—	30	ns
			3.0	—	7	10	—	14	ns
Input capacitance	$C_{IN}$	—	—	5	10	—	10	pF	
Equivalent internal capacitance	$C_{PD}^{*1}$	—	—	10	—	—	—	pF	

\*1.  $C_{PD}$  is the no-load equivalent capacitance inside the circuitry. Refer to the measurement circuit shown below. Current consumption is averaged by the following equation.

$$I_{CC(opr)} = C_{PD} \times V_{CC} \times fin + I_{CC}$$

Measurement Circuit

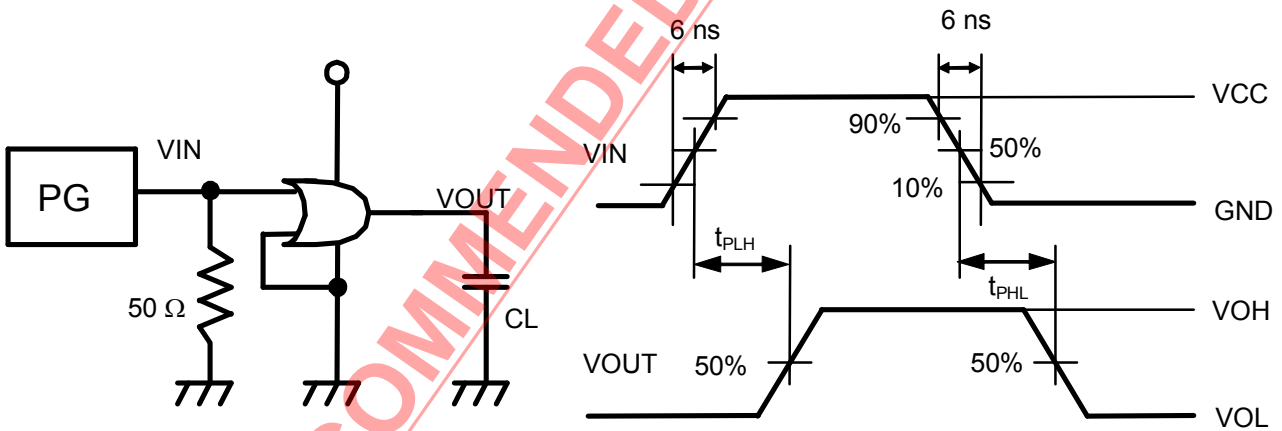

Remark No-load output during measurement of current consumption.

■ Input Pin Equivalent Circuit

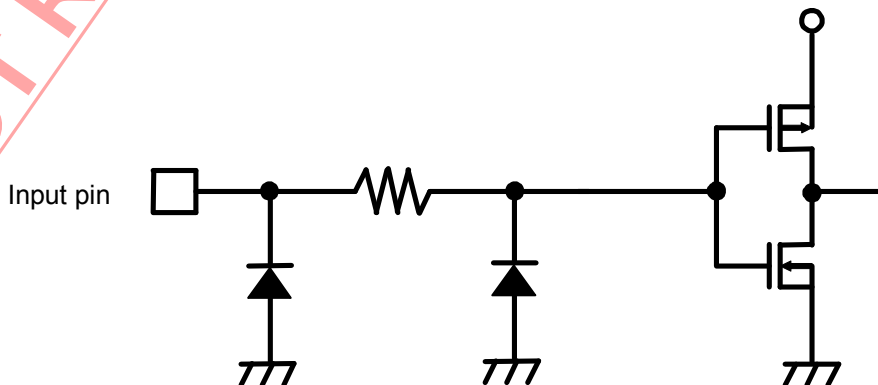

The S-75L86ANC is an EXCLUSIVE OR GATE fabricated by utilizing advanced silicon-gate CMOS technology which provides the inherent benefit of CMOS low power consumption to achieve operation by only a couple of batteries (1 to 3 V). The internal circuitry has buffered outputs to ensure high noise immunity and output stability.

Input voltage is allowed to be applied even if power voltage is not supplied because no diode is inserted between an input pin and  $V_{CC}$ .

This allows for interfaces between power supplies of different voltage, output level conversion from 3 V to 1 V and battery backup applications.

### ■ Features

- Wide power supply range: 1 V to 3.6 V
- Low current consumption: 1.0  $\mu$ A max. (at 3.6 V, 25°C)
- Typical propagation delay:  $t_{PD} = 7$  ns (at 3 V)
- High noise immunity:  $V_{NIH} = V_{NIL} = 28\% V_{CC}$  min.
- Power down protection: All pins
- Lead-free

### ■ Applications

- Personal computers, peripherals
- Cellular phones
- Cameras
- Games

### ■ Package

- SC-88A

### ■ Pin Configuration

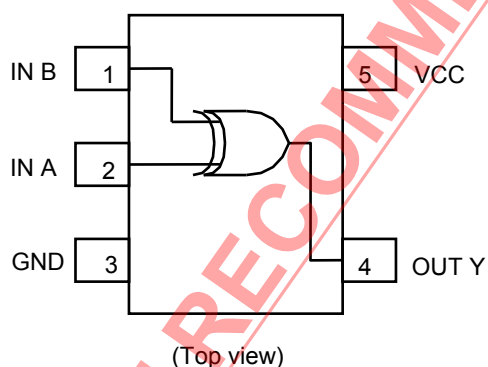

### ■ Marking Specification

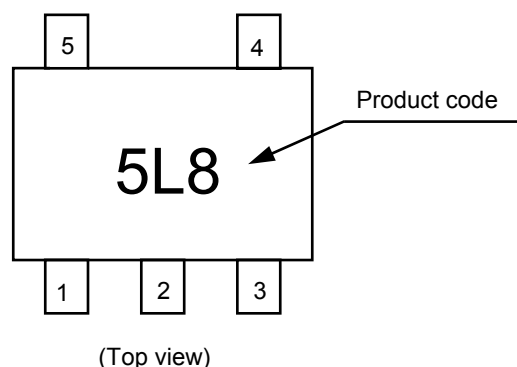

### ■ Logic Diagram

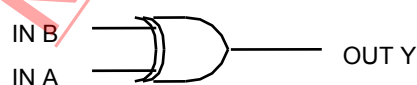

True values

A	B	Y
L	L	L
L	H	H
H	L	H
H	H	L

■ Product Name Structure

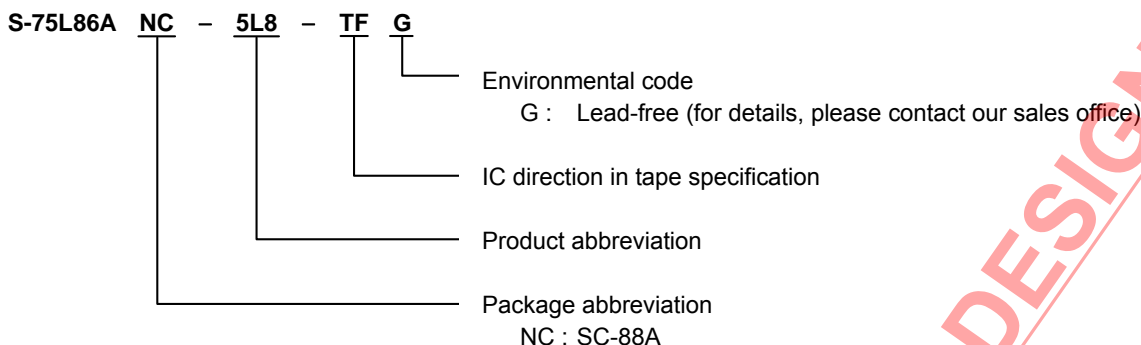

■ Absolute Maximum Ratings

(Ta = 25°C unless otherwise specified)

Item	Symbol	Absolute Maximum Ratings	Unit
Power supply voltage	$V_{CC}$	-0.5 to +5.0	V
Input voltage	$V_{IN}$	-0.5 to +5.0	V
Output voltage	$V_{OUT}$	-0.5 to $V_{CC} + 0.5$	V
Input parasitic diode current	$I_{IK}$	-20	mA
Output parasitic diode current	$I_{OK}$	±20	mA
Output current	$I_{OUT}$	±12.5	mA
$V_{CC}/GND$ current	$I_{CC}$	±25	mA
Power dissipation	$P_D$	200 (When not mounted on board)	mW
		350*1	mW
Operating ambient temperature	$T_{opr}$	-40 to +85	°C
Storage temperature	$T_{stg}$	-65 to +150	°C
Lead temperature (10 s)	$T_L$	260	°C

\*1. When mounted on board  
[Mounted board]

- (1) Board size : 114.3 mm × 76.2 mm × 1.6 mm
- (2) Board name : JEDEC STANDARD51-7

**Caution** The absolute maximum ratings are rated values exceeding which the product could suffer physical damage. These values must therefore not be exceeded under any conditions.

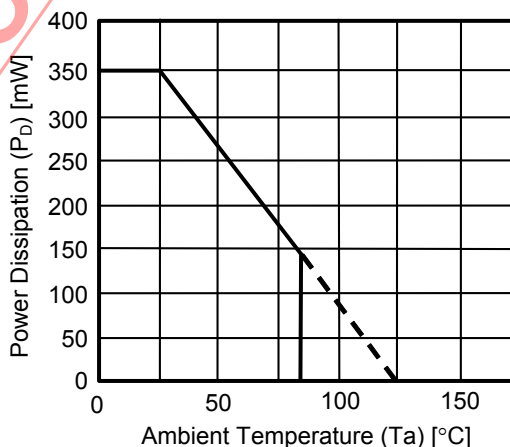

Power Dissipation of Package (When Mounted on Board)

### ■ Recommended Operating Conditions

Item	Symbol	Standard	Unit
Power voltage	$V_{CC}$	1 to 3.6	V
Input voltage	$V_{IN}$	0 to 3.6	V
Output voltage	$V_{OUT}$	0 to $V_{CC}$	V
Input rise / fall time	$t_R, t_F$	0 to 1000 ( $V_{CC} = 1.0$ V)	ns
		0 to 500 ( $V_{CC} = 2.0$ V)	ns
		0 to 400 ( $V_{CC} = 3.0$ V)	ns

### ■ DC Electrical Characteristics

Item	Symbol	Conditions	$T_a = 25^\circ\text{C}$			$T_a = -40$ to $85^\circ\text{C}$		Unit			
			$V_{CC}$	Min.	Typ.	Max.	Min.		Max.		
Input voltage	"H" level	$V_{IH}$	—	1.0	0.75	—	—	0.75	—	V	
				1.5	1.05	—	—	1.05	—	V	
				3.0	2.10	—	—	2.10	—	V	
	"L" level	$V_{IL}$	—	1.0	—	—	0.25	—	0.25	V	
				1.5	—	—	0.45	—	0.45	V	
				3.0	—	—	0.90	—	0.90	V	
Output voltage	"H" level	$V_{OH}$	$V_{IN} = V_{IH}$ or $V_{IL}$	$I_{OH} = -20 \mu\text{A}$	1.0	0.9	1.0	—	0.9	—	V
					1.5	1.4	1.5	—	1.4	—	V
					3.0	2.9	3.0	—	2.9	—	V
				$I_{OH} = -1 \text{ mA}$	1.5	1.07	1.23	—	0.99	—	V
					3.0	2.61	2.68	—	2.55	—	V
					3.0	2.61	2.68	—	2.55	—	V
	"L" level	$V_{OL}$	$V_{IN} = V_{IH}$ or $V_{IL}$	$I_{OL} = 20 \mu\text{A}$	1.0	—	0	0.1	—	0.1	V
					1.5	—	0	0.1	—	0.1	V
					3.0	—	0	0.1	—	0.1	V
				$I_{OL} = 1 \text{ mA}$	1.5	—	0.23	0.31	—	0.37	V
					3.0	—	0.23	0.31	—	0.33	V
					3.0	—	0.23	0.31	—	0.33	V
Input current	$I_{IN}$	$V_{IN} = V_{CC}$ or GND	3.6	—	—	$\pm 0.1$	—	$\pm 1.0$	$\mu\text{A}$		
Current consumption	$I_{CC}$	$V_{IN} = V_{CC}$ or GND	3.6	—	—	1.0	—	10.0	$\mu\text{A}$		

■ AC Electrical Characteristics

( $C_L = 15\text{ pF}$ , Input  $t_R = t_F = 6\text{ ns}$ ,  $V_{CC} = 3.3 \pm 0.3\text{ V}$ ,  $T_a = 25^\circ\text{C}$  unless otherwise specified)

Item	Symbol	Measurement Conditions	Min.	Typ.	Max.	Unit
Output rise / fall time	$t_{TLH}$ , $t_{THL}$	—	—	4.0	8.0	ns
Propagation delay time	$t_{PLH}$ , $t_{PHL}$	—	—	6.0	9.0	ns

( $C_L = 25\text{ pF}$ , Input  $t_R = t_F = 6\text{ ns}$  unless otherwise specified)

Item	Symbol	Measurement Conditions	$T_a = 25^\circ\text{C}$			$T_a = -40\text{ to }85^\circ\text{C}$		Unit	
			$V_{CC}\text{ (V)}$	Min.	Typ.	Max.	Min.		Max.
Output rise / fall time	$t_{TLH}$ , $t_{THL}$	—	1.0	—	35	70	—	90	ns
			1.5	—	15	25	—	30	ns
			3.0	—	7	10	—	14	ns
Propagation delay time	$t_{PLH}$ , $t_{PHL}$	—	1.0	—	30	60	—	75	ns
			1.5	—	15	25	—	30	ns
			3.0	—	7	10	—	14	ns
Input capacitance	$C_{IN}$	—	—	5	10	—	10	pF	
Equivalent internal capacitance	$C_{PD}^{*1}$	—	—	10	—	—	—	pF	

\*1.  $C_{PD}$  is the no-load equivalent capacitance inside the circuitry. Refer to the measurement circuit shown below. Current consumption is averaged by the following equation.

$$I_{CC(opr)} = C_{PD} \times V_{CC} \times fin + I_{CC}$$

Measurement Circuit

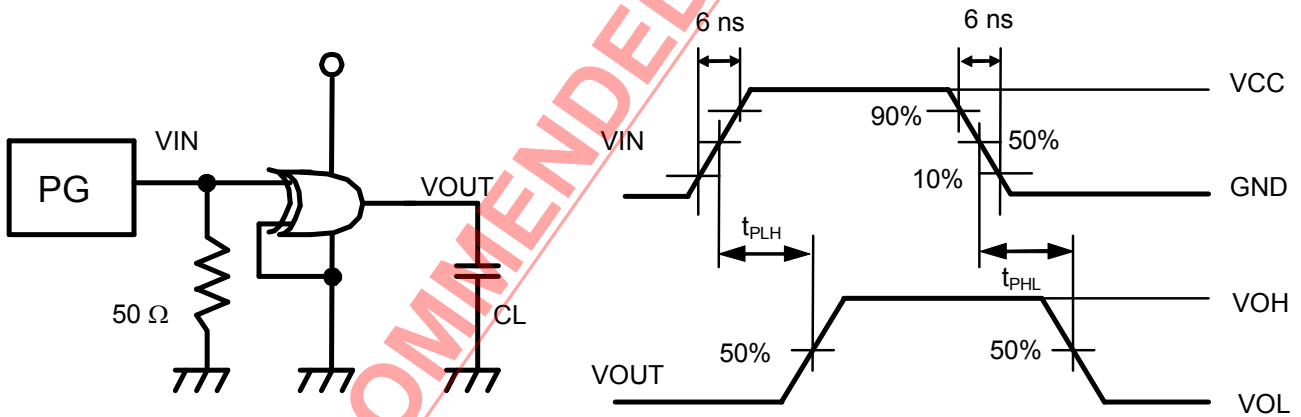

Remark No-load output during measurement of current consumption.

■ Input Pin Equivalent Circuit

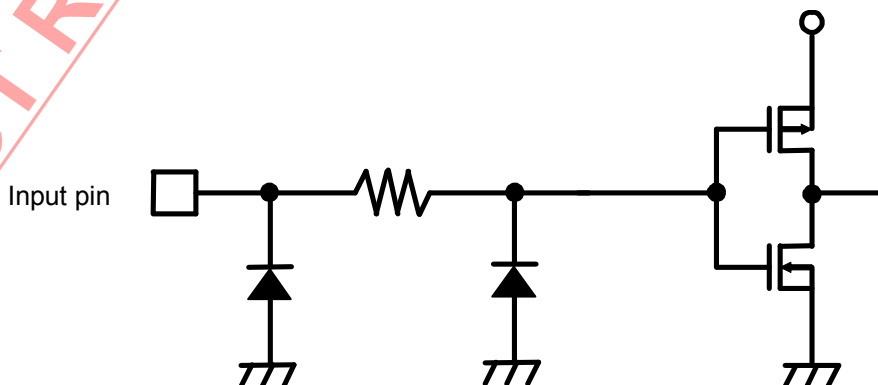



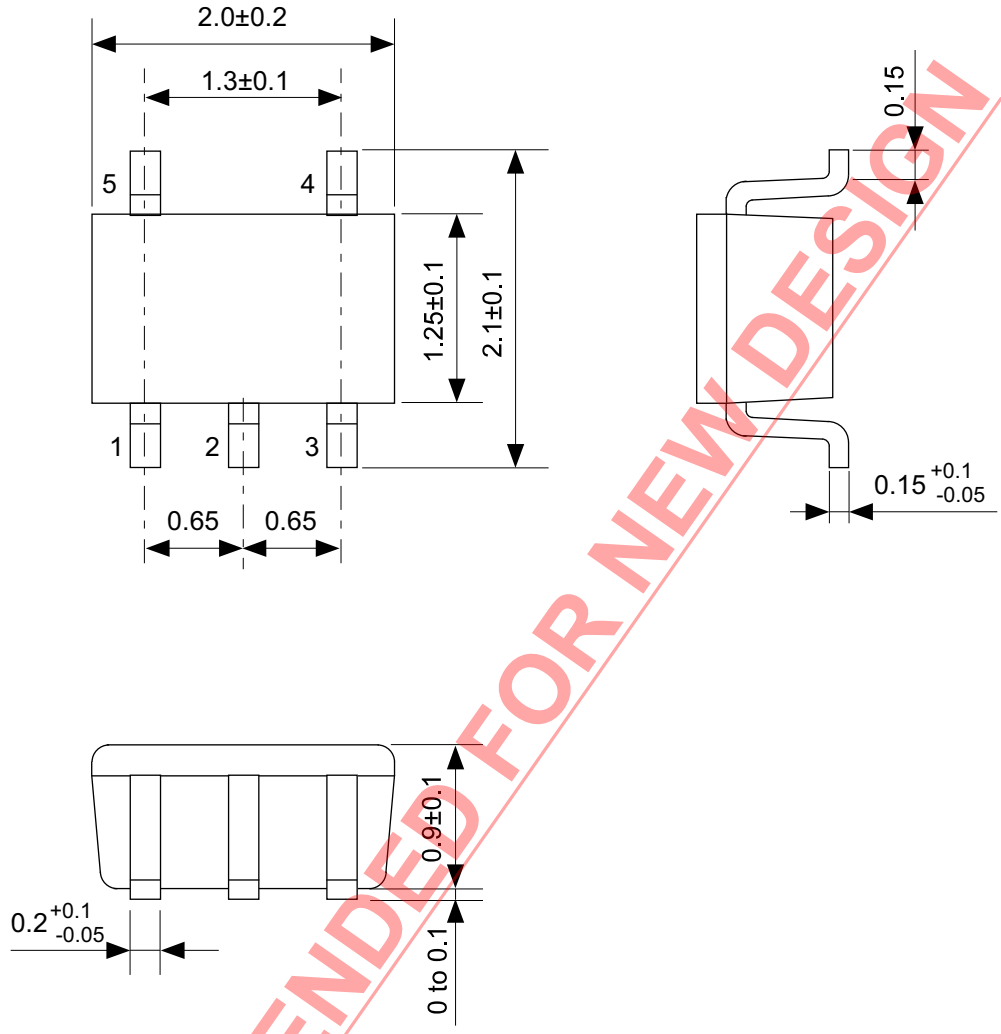

NOT RECOMMENDED FOR NEW DESIGN

No. NP005-B-P-SD-1.2

TITLE	SC88A-B-PKG Dimensions
No.	NP005-B-P-SD-1.2
ANGLE	
UNIT	mm
<b>ABLIC Inc.</b>	

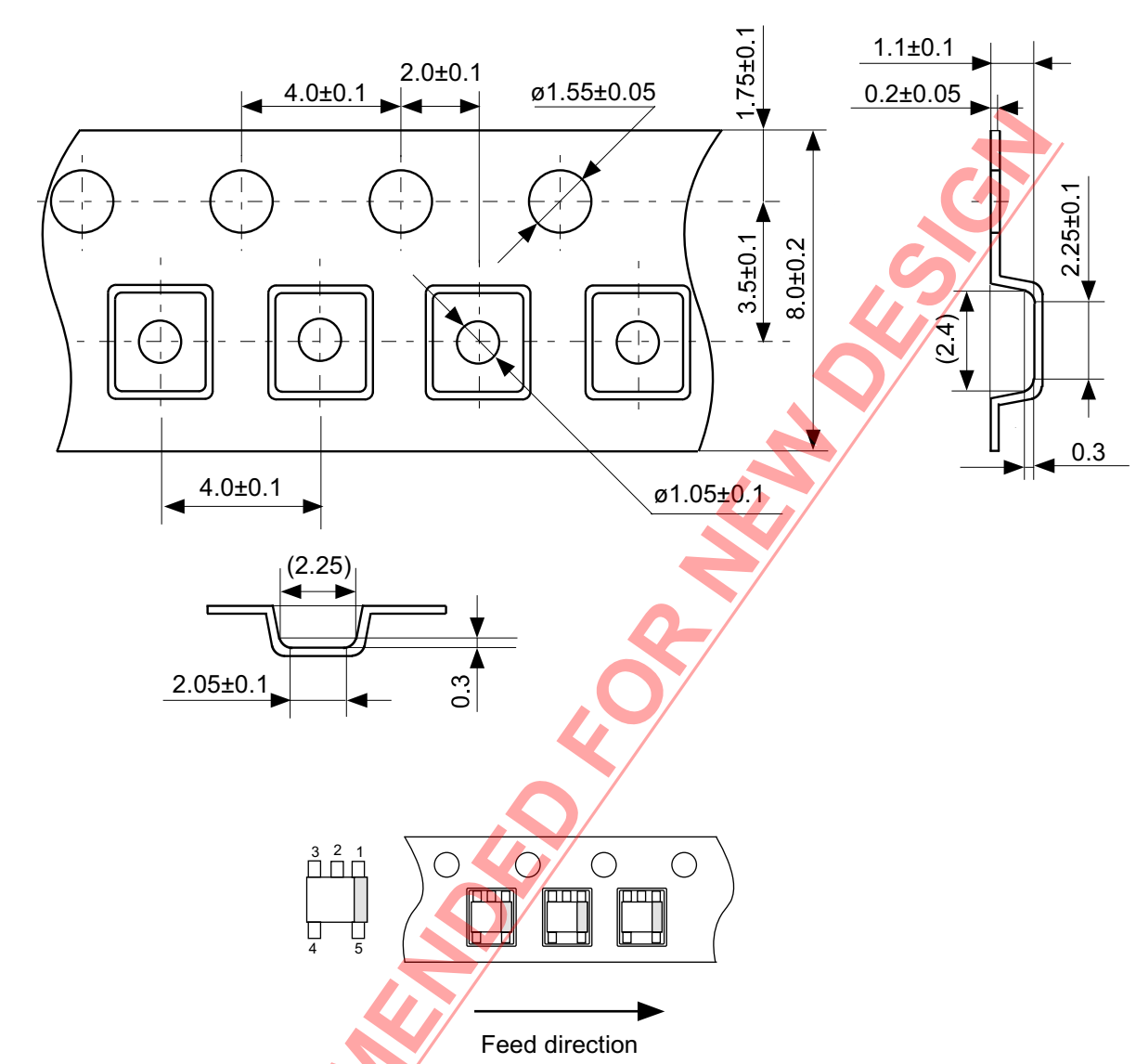

NOT RECOMMENDED FOR NEW DESIGN

No. NP005-B-C-SD-2.0

TITLE	SC88A-B-Carrier Tape
No.	NP005-B-C-SD-2.0
ANGLE	
UNIT	mm
<b>ABLIC Inc.</b>	

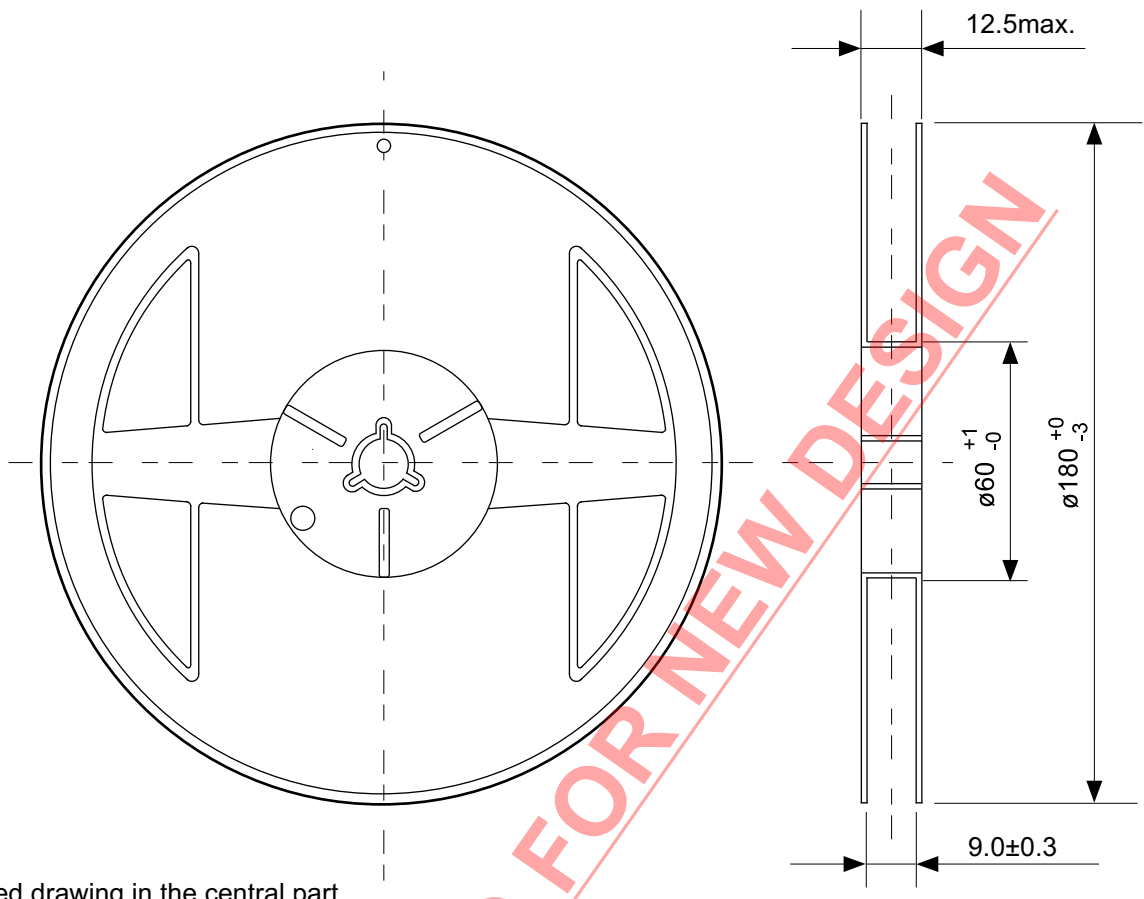

NOT RECOMMENDED FOR NEW DESIGN

No. NP005-B-R-SD-2.1

TITLE	SC88A-B-Reel		
No.	NP005-B-R-SD-2.1		
ANGLE		QTY.	3,000
UNIT	mm		
<b>ABLIC Inc.</b>			

## Disclaimers (Handling Precautions)

1. All the information described herein (product data, specifications, figures, tables, programs, algorithms and application circuit examples, etc.) is current as of publishing date of this document and is subject to change without notice.
2. The circuit examples and the usages described herein are for reference only, and do not guarantee the success of any specific mass-production design.  
ABLIC Inc. is not responsible for damages caused by the reasons other than the products described herein (hereinafter "the products") or infringement of third-party intellectual property right and any other right due to the use of the information described herein.
3. ABLIC Inc. is not responsible for damages caused by the incorrect information described herein.
4. Be careful to use the products within their specified ranges. Pay special attention to the absolute maximum ratings, operation voltage range and electrical characteristics, etc.  
ABLIC Inc. is not responsible for damages caused by failures and / or accidents, etc. that occur due to the use of the products outside their specified ranges.
5. When using the products, confirm their applications, and the laws and regulations of the region or country where they are used and verify suitability, safety and other factors for the intended use.
6. When exporting the products, comply with the Foreign Exchange and Foreign Trade Act and all other export-related laws, and follow the required procedures.
7. The products must not be used or provided (exported) for the purposes of the development of weapons of mass destruction or military use. ABLIC Inc. is not responsible for any provision (export) to those whose purpose is to develop, manufacture, use or store nuclear, biological or chemical weapons, missiles, or other military use.
8. The products are not designed to be used as part of any device or equipment that may affect the human body, human life, or assets (such as medical equipment, disaster prevention systems, security systems, combustion control systems, infrastructure control systems, vehicle equipment, traffic systems, in-vehicle equipment, aviation equipment, aerospace equipment, and nuclear-related equipment), excluding when specified for in-vehicle use or other uses. Do not apply the products to the above listed devices and equipments without prior written permission by ABLIC Inc. Especially, the products cannot be used for life support devices, devices implanted in the human body and devices that directly affect human life, etc.  
Prior consultation with our sales office is required when considering the above uses.  
ABLIC Inc. is not responsible for damages caused by unauthorized or unspecified use of our products.
9. Semiconductor products may fail or malfunction with some probability.  
The user of the products should therefore take responsibility to give thorough consideration to safety design including redundancy, fire spread prevention measures, and malfunction prevention to prevent accidents causing injury or death, fires and social damage, etc. that may ensue from the products' failure or malfunction.  
The entire system must be sufficiently evaluated and applied on customer's own responsibility.
10. The products are not designed to be radiation-proof. The necessary radiation measures should be taken in the product design by the customer depending on the intended use.
11. The products do not affect human health under normal use. However, they contain chemical substances and heavy metals and should therefore not be put in the mouth. The fracture surfaces of wafers and chips may be sharp. Be careful when handling these with the bare hands to prevent injuries, etc.
12. When disposing of the products, comply with the laws and ordinances of the country or region where they are used.
13. The information described herein contains copyright information and know-how of ABLIC Inc.  
The information described herein does not convey any license under any intellectual property rights or any other rights belonging to ABLIC Inc. or a third party. Reproduction or copying of the information from this document or any part of this document described herein for the purpose of disclosing it to a third-party without the express permission of ABLIC Inc. is strictly prohibited.
14. For more details on the information described herein, contact our sales office.

2.0-2018.01

## X-ON Electronics

Largest Supplier of Electrical and Electronic Components

*Click to view similar products for [Logic Gates](#) category:*

*Click to view products by [ABLIC](#) manufacturer:*

Other Similar products are found below :

[74HC85N](#) [NLU1G32AMUTCG](#) [NLVHC1G08DFT1G](#) [CD4068BE](#) [NL17SG32P5T5G](#) [NL17SG86DFT2G](#) [NLV14001UBDR2G](#)  
[NLX1G11AMUTCG](#) [NLX1G97MUTCG](#) [74LS38](#) [74LVC32ADTR2G](#) [MC74HCT20ADTR2G](#) [NLV17SZ00DFT2G](#) [NLV17SZ02DFT2G](#)  
[NLV74HC02ADR2G](#) [74HC32S14-13](#) [74LS133](#) [M38510/30402BDA](#) [74LVC1G86Z-7](#) [74LVC2G08RA3-7](#) [NLV74HC08ADTR2G](#)  
[NLV74HC14ADR2G](#) [NLV74HC20ADR2G](#) [NLX2G86MUTCG](#) [5962-8973601DA](#) [74LVC2G02HD4-7](#) [NLU1G00AMUTCG](#)  
[74LVC2G32RA3-7](#) [74LVC2G00HD4-7](#) [NL17SG02P5T5G](#) [74LVC2G00HK3-7](#) [74LVC2G86HK3-7](#) [NLX1G99DMUTWG](#)  
[NLVVHC1G00DFT2G](#) [NLVHC1G08DFT2G](#) [NLV7SZ57DFT2G](#) [NLV74VHC04DTR2G](#) [NLV27WZ86USG](#) [NLV27WZ00USG](#)  
[NLU1G86CMUTCG](#) [NLU1G08CMUTCG](#) [NL17SZ32P5T5G](#) [NL17SZ00P5T5G](#) [NL17SH02P5T5G](#) [74AUP2G00RA3-7](#)  
[NLV74HC02ADTR2G](#) [NLX1G332CMUTCG](#) [NL17SG86P5T5G](#) [NL17SZ05P5T5G](#) [NLV74VHC00DTR2G](#)