

CRYSTAL-LESS PCI EXPRESS DUAL OUTPUT ULTRA MINIATURE PURE SILICON™ SMD CLOCK GENERATOR

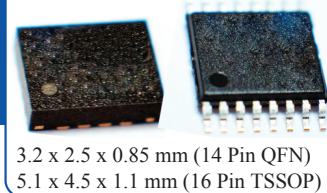

AB-557-03 Series

Moisture Sensitivity Level
MSL 1 – 14 QFN
MSL 3 – 16 TSSOP



RoHS/RoHS II compliant

FEATURES:

- Meets PCIe Gen1, Gen2, & Gen3 specs.
- High Performance MEMS Technology by Discera
- Available Mixed Output Formats: HCSL, LVPECL, LVDS or LVCMOS
- Wide Temperature Range: -40° to 105° C
- Wide Supply Range: 2.25V to 3.6 V
- Low Power Consumption
- Excellent Shock & Vibration Immunity

APPLICATIONS:

- Solid State Storage
- Storage Area Networks
- Passive Optical Networks
- Ethernet: 1G, 10GBASE-T/KR/LR/SR, and FCoE
- TV and other Consumer Electronics
- Industrial and Medical
- Scanner, Printer

STANDARD SPECIFICATIONS:

Parameters	Minimum	Typical	Maximum	Units	Notes	
Frequency	f_0	2.3	100	460*1	MHz	
Operating Temperature		-20		+70	°C	See options
Storage Temperature		-55		+150	°C	
Overall Freq. Stability*2	Δf	-100		+100	ppm	See options
Supply Voltage	V_{DD}	+2.25		+3.6	V	
Supply Current- Enabled	I_{DD}		60		mA	$R_L=50\Omega$, $F_{01}=F_{02}=100.00\text{MHz}$
Supply Current- Disabled	I_{DD}		21	23	mA	
Startup Time	t_{su}			5	ms	
Enable Time	t_{EN}			20	ns	
Disable Time	t_{DA}			5	ns	
Tri-state Function (Standby/Disable)		"1" ($V_{IH} \geq 0.75 * V_{DD}$) or Open: Oscillation "0" ($V_{IL} < 0.25 * V_{DD}$) : Hi Z		V	40k Ω pull-up resistor embedded	
Aging		-5.0		+5.0	ppm	First year
Output Offset Voltage	V_{OH} V_{OL}	0.725		0.10	V	$R_L=50 \Omega$
Peak to Peak Output Swing			750		mV	Single-Ended
Rise Time	t_r	200		400	ps	$R_L=50 \Omega$, $C_L=2\text{pF}$
Fall Time	t_f	200		400	ps	20% to 80%
Duty Cycle	SYM	48		52	%	Differential
Period Jitter	J_{PER}		2.5		pSRMS	$F_{01}=F_{02}=100.00\text{MHz}$
Integrated Phase Noise (Common Clock Architecture)	R_J		0.540		pSRMS	PCIe Gen 1.1 $T_J = D_J + 14.069 \times R_J$ (BER 10-12)
	D_J		0.832	41.9	pSP-P	
	T_J		8.536	86.0		
	$J_{RMS-CCHF}$		0.458	3.1	pSRMS	PCIe Gen 2.1 1.5 MHz to Nyquist
	$J_{RMS-CCLF}$		0.030	3.0		PCIe Gen 2.1 10kHz to 1.5 MHz
	J_{RMS-CC}		0.165	1.0		PCIe Gen 3.0
Integrated Phase Noise (Data Clock Architecture)	$J_{RMS-DCHF}$		0.561	4.0	pSRMS	PCIe Gen 2.1 1.5 MHz to Nyquist
	$J_{RMS-DCLF}$		1.778	7.5		PCIe Gen 2.1 10kHz to 1.5 MHz
	J_{RMS-DC}		0.147	1.0		PCIe Gen 3.0

*1. For frequency other than 100MHz, please contact ABRACON or consider using ASEMDxx series

2. Frequency stability includes frequency variations due to initial tolerance, temp. and power supply voltage

ABRACON IS
ISO9001:2008
CERTIFIED



2 Faraday, Suite# B | Irvine | CA 92618 Revised:12.21.15
Ph. 949.546.8000 | Fax. 949.546.8001

Visit www.abracon.com for Terms and Conditions of Sale

CRYSTAL-LESS PCI EXPRESS DUAL OUTPUT ULTRA MINIATURE PURE SILICON™ SMD CLOCK GENERATOR

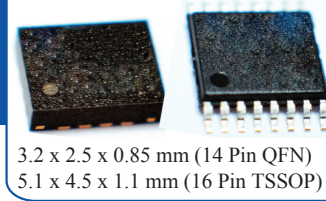

AB-557-03 Series

Pb RoHS/RoHS II compliant

Absolute Maximum Ratings

Item	Minimum	Maximum	Unit	Condition
Supply Voltage	-0.3	+4.0	V	
Input Voltage	-0.3	V _{dd} +0.3	V	
Junction Temp.		+150	°C	
Storage Temp.	-55	+150	°C	
Soldering Temp.		+260	°C	40sec max
ESD				
HBM		4,000	V	
MM		400		
CDM		1,500		

Block Diagram:

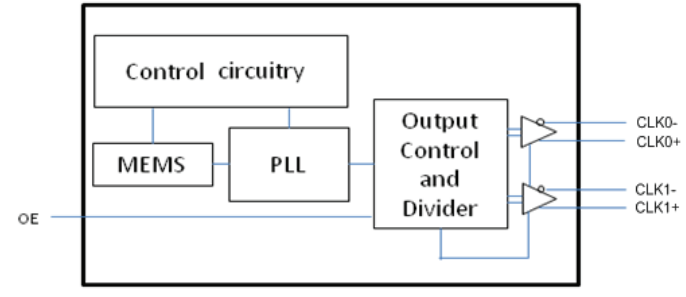

PIN LAYOUT:

14 Pin QFN:

Pin Diagram

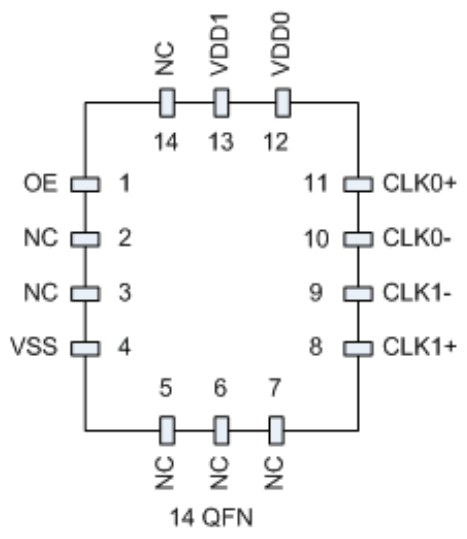

Connection Diagram Two HCSL Outputs

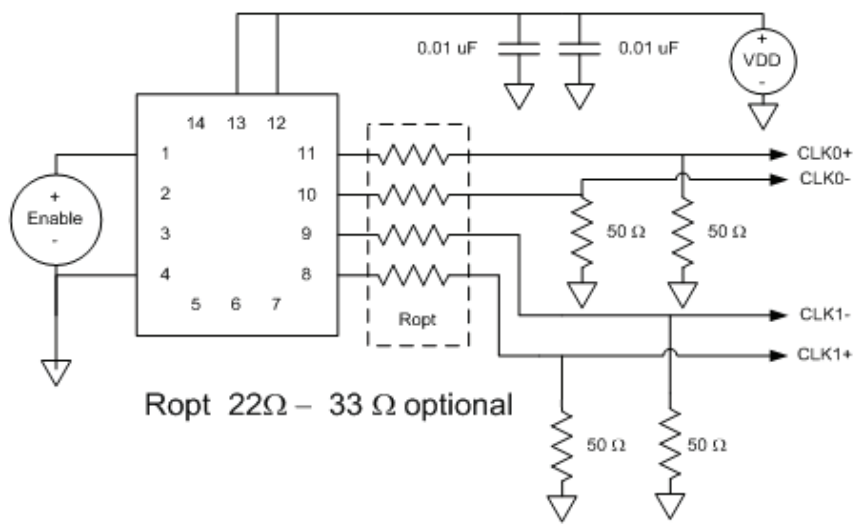

Pin No.	Pin Name	Pin Type	Description
1	OE	I	Output Enable; active high
2	NC	NA	Ground Connected or Leave Unconnected
3	NC	NA	Ground Connected or Leave Unconnected
4	VSS	Power	Ground
5	NC	NA	Ground Connected or Leave Unconnected
6	NC	NA	Ground Connected or Leave Unconnected
7	NC	NA	Ground Connected or Leave Unconnected
8	CLK1+	O	True output of differential pair
9	CLK1-	O	Complement output of differential pair
10	CLK0-	O	Complement output of differential pair
11	CLK0+	O	True output of differential pair
12	VDD0	Power	Power Supply for Output 0 (CLK+/- 0)
13	VDD1	Power	Power Supply for Core and Output 1 (CLK +/- 1)
14	NC	NA	Ground Connected or Leave Unconnected

CRYSTAL-LESS PCI EXPRESS DUAL OUTPUT ULTRA MINIATURE PURE SILICON™ SMD CLOCK GENERATOR

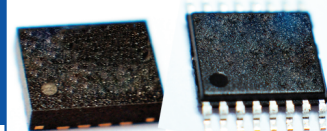

3.2 x 2.5 x 0.85 mm (14 Pin QFN)
5.1 x 4.5 x 1.1 mm (16 Pin TSSOP)

AB-557-03 Series



RoHS/RoHS II compliant

16 Pin TSSOP:

Pin Diagram

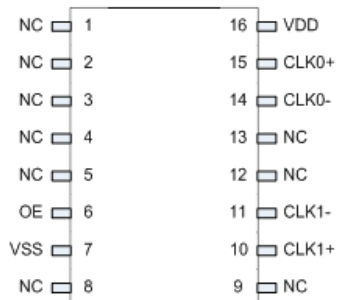

16-pin TSSOP

Connection Diagram Two HCSL Outputs

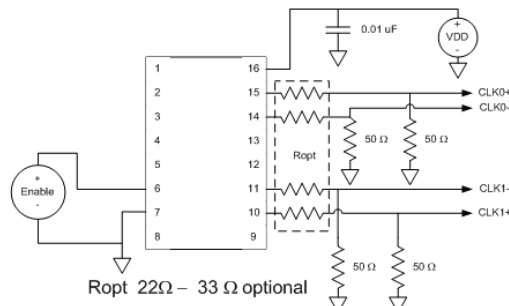

Pin No.	Pin Name	Pin Type	Description
1	NC	NA	Leave Unconnected
2	NC	NA	Leave Unconnected
3	NC	NA	Leave Unconnected
4	NC	NA	Leave Unconnected
5	NC	NA	Leave Unconnected
6	OE	I	Output Enable; active high
7	VSS	Power	Ground
8	NC	NA	Leave Unconnected
9	NC	NA	Leave Unconnected
10	CLK1+	O	True output of differential pair
11	CLK1-	O	Complement output of differential pair
12	NC	NA	Leave Unconnected
13	NC	NA	Leave Unconnected
14	CLK0-	O	Complement output of differential pair
15	CLK0+	O	True output of differential pair
16	VDD	Power	Power Supply

PART IDENTIFICATION:

AB-557-03-□□ - □ - □ - □ - □

Output Format, Clk1
C: LVCMOS
LP: LVPECL
LV: LVDS
HC: HCSL

Output Format, Clk0
C: LVCMOS
LP: LVPECL
LV: LVDS
HC: HCSL

Package Type
F: 14-QFN
S: 16-TSSOP

Operating Temp.
E: -20°C ~ +70°C
L: -40°C ~ +85°C
X: -40°C ~ +105°C

Overall Freq. Stability
Blank: ±100ppm
C: ±50ppm

Packaging
Blank: Bulk
T: Tape & Reel(1kpcs / reel)
T3: Tape & Reel(3kpcs/reel)

Note: For frequency other than 100MHz, please contact ABRACON or consider using ASEMDxx series

ABRACON IS
ISO9001:2008
CERTIFIED



2 Faraday, Suite# B | Irvine | CA 92618 Revised:12.21.15
Ph. 949.546.8000 | Fax. 949.546.8001

Visit www.abracon.com for Terms and Conditions of Sale

CRYSTAL-LESS PCI EXPRESS DUAL OUTPUT ULTRA MINIATURE PURE SILICON™ SMD CLOCK GENERATOR

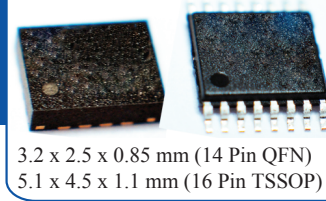

AB-557-03 Series

Pb | RoHS/RoHS II compliant

3.2 x 2.5 x 0.85 mm (14 Pin QFN)
5.1 x 4.5 x 1.1 mm (16 Pin TSSOP)

OUTLINE DRAWING:

14 Pin QFN:

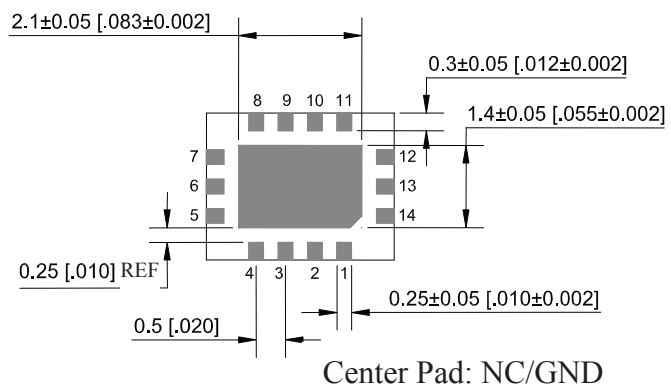
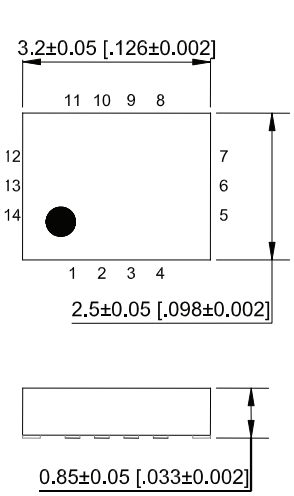

Recommended Solder Pad Layout

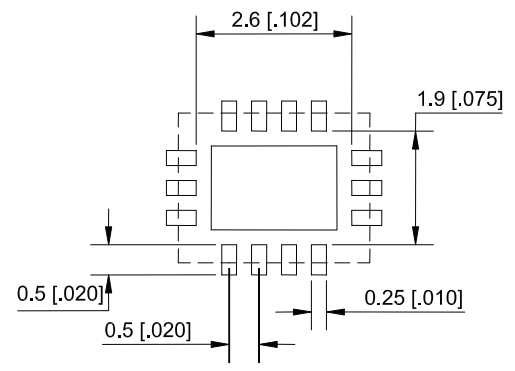

16 Pin TSSOP:

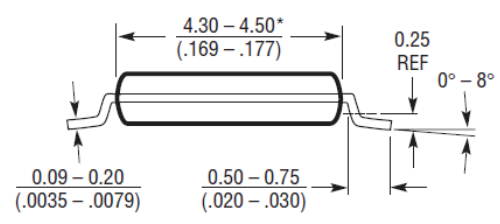
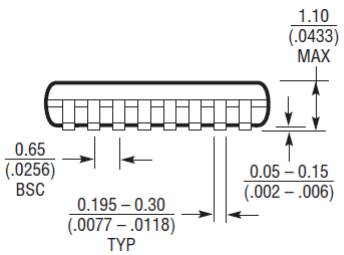

Recommended Solder Pad Layout

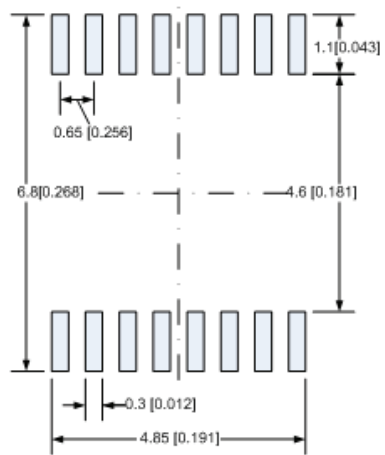
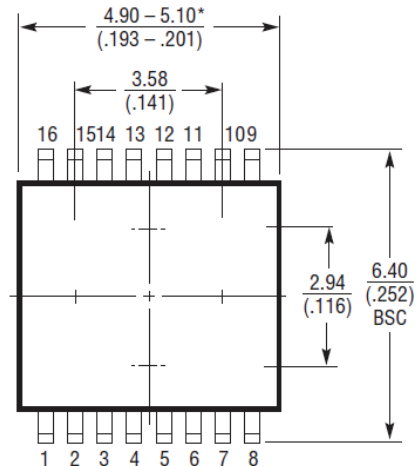

* Dimensions do not include mold flash. Mold flash shall not exceed 0.150mm (.006 inches) per side.

Dimensions: mm (inches)

ABRACON IS
ISO9001:2008
CERTIFIED



2 Faraday, Suite# B | Irvine | CA 92618 **Revised:12.21.15**
Ph. 949.546.8000 | Fax. 949.546.8001
Visit www.abracon.com for Terms and Conditions of Sale

CRYSTAL-LESS PCI EXPRESS DUAL OUTPUT ULTRA MINIATURE PURE SILICON™ SMD CLOCK GENERATOR

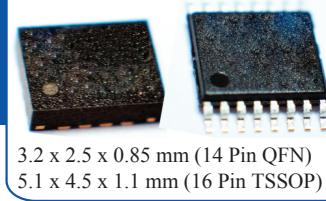

AB-557-03 Series



RoHS/RoHS II compliant

3.2 x 2.5 x 0.85 mm (14 Pin QFN)
5.1 x 4.5 x 1.1 mm (16 Pin TSSOP)

REFLOW PROFILE:

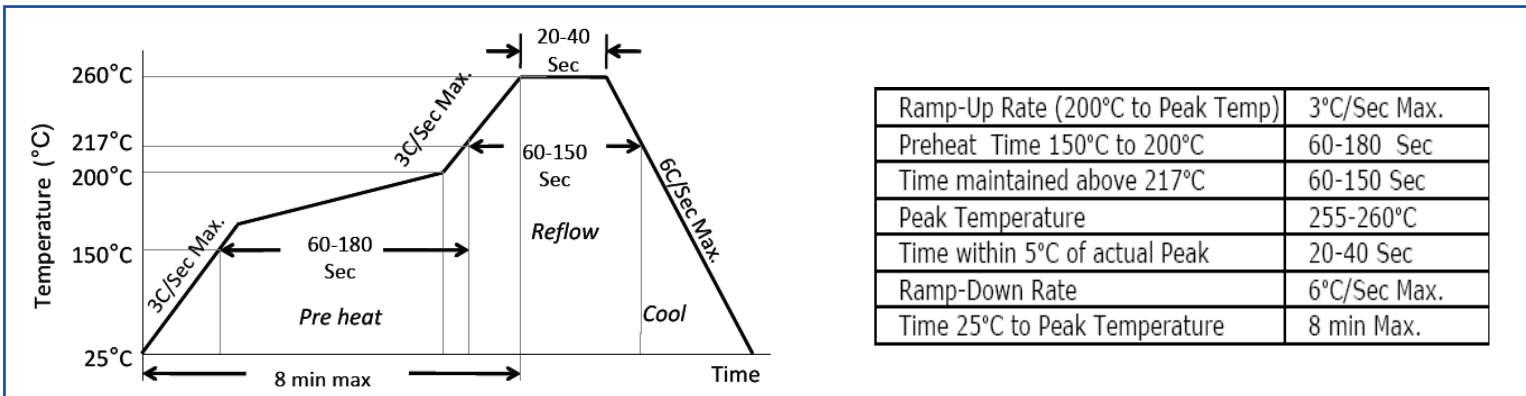

TAPE & REEL:

14 Pin QFN Tape Drawing:

T= 1,000pcs/reel
T3= 3,000pcs/reel

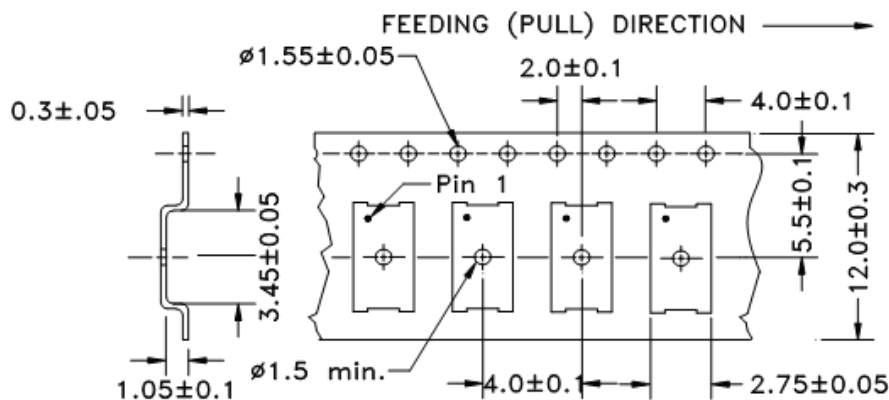

16 Pin TSSOP Tape Drawing

T= 1,000pcs/reel
T3= 3,000pcs/reel

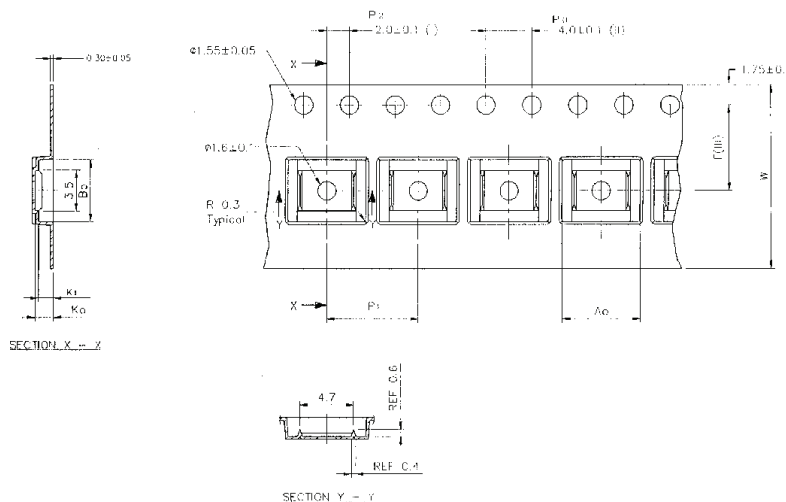

A0	B0	K0	K1	F	P1	W
6.80±0.1	5.40±0.1	1.60±0.1	1.30±0.1	5.50±0.1	8.00±0.1	12.00±0.3

Dimensions: mm

X-ON Electronics

Largest Supplier of Electrical and Electronic Components

Click to view similar products for [Clock Generators & Support Products](#) category:

Click to view products by [ABRACON](#) manufacturer:

Other Similar products are found below :

[5P49V5901A748NLGI](#) [5P49V5901B680NLGI](#) [5P49V5901B744NLGI](#) [5P49V5929B502NLGI](#) [5P49V5935B520LTGI](#) [5V49EE903-116NLGI](#)
[CV183-2TPAG](#) [82P33814ANLG/W](#) [8T49N004A-002NLGI](#) [8T49N004A-039NLGI](#) [9FGV0631CKLF](#) [9FGV0641AKLFT](#) [9LRS3197AKLF](#)
[9UMS9633BFILF](#) [9VRS4450AKLF](#) [NB3N51132DTR2G](#) [8N3Q001EG-0035CDI](#) [932SQ426AKLF](#) [950810CGLF](#) [9DBV0531AKILF](#)
[9DBV0741AKILF](#) [9FGV0641AKLF](#) [9UMS9633BKLF](#) [9VRS4420DKILF](#) [9VRS4420DKLF](#) [9VRS4420DKLFT](#) [CY25404ZXI226](#)
[CY25422SXI-004](#) [5P49V5901B712NLGI](#) [NB3H5150-01MNTXG](#) [6INT61041NDG](#) [PL602-20-K52TC](#) [PL613-51QC](#) [8N3Q001FG-1114CDI](#)
[9FGV0641AKILF](#) [ZL30314GKG2](#) [ZL30253LDG1](#) [ZL30251LDG1](#) [ZL30250LDG1](#) [ZL30169LDG1](#) [ZL30142GGG2](#) [9UMS9633BKILFT](#)
[9FGV0631CKLFT](#) [9FGV0631CKILF](#) [5P49V5935B536LTGI](#) [PI6LC48P0101LIE](#) [DS1099U-ST+](#) [MAX24305EXG+](#) [PI6LC48H02-01LIE](#)
[82P33814ANLG](#)