

# IoT OPTIMIZED LOW PROFILE QUARTZ CRYSTAL



2.0 x 1.6 x 0.50 mm

RoHS/RoHS II Compliant

MSL = N/A: NOT APPLICABLE (See Note #1)

**ABM11-143-27.120MHz**

## FEATURES

- Optimized for low power consumption, wearables, and IoT applications
- Guaranteed low 40Ω ESR ensures operation in power sensitive solutions
- 0.50mm max height ideally suited for height constrained designs
- -40°C to 85°C industrial operating temperature range
- Seam sealed for long-term reliability

## APPLICATIONS

- Wearables
- Internet of Things (IoT)/Industrial (IIoT)
- Bluetooth/Bluetooth Low Energy (BLE)
- Machine-to-machine (M2M) connectivity
- Ultra-low power MCU
- Near Field Communication (NFC)
- Wireless modules
- ISM Band

## STANDARD SPECIFICATIONS

PARAMETERS	MINIMUM	TYPICAL	MAXIMUM	UNITS	NOTES
Frequency	27.120			MHz	
Operation Mode	Fundamental				
Operating Temperature	-40		+85	°C	
Storage Temperature	-40		+125	°C	
Frequency Tolerance @+25°C	-10		+10	ppm	See Note #2
Frequency Stability over the Operating Temperature ( ref. to +25°C)	-30		+30	ppm	See Note #3
Equivalent series resistance (R1)			40	Ω	
Shunt capacitance (C0)			2	pF	
Load capacitance (CL)	8			pF	
Drive Level		10	100	μW	
Aging@25°C±3°C			±3	ppm	First year
Insulation Resistance	500			MΩ	@ 100Vdc ± 15V

**Note#1:** Moisture Sensitivity Level (MSL) – This product is Hermetically Sealed and not Moisture Sensitive

**Note#2:** Referenced to crystal resonant frequency, into an oscillator loop effective load of 8pF

**Note#3:** Referenced to the measured frequency at 25°C±3°C, into an oscillator loop effective load of 8pF

REVISED: 06/21/2016

# IoT OPTIMIZED LOW PROFILE QUARTZ CRYSTAL



2.0 x 1.6 x 0.50 mm

**Pb** RoHS/RoHS II Compliant

MSL = N/A: NOT APPLICABLE (See Note #1)

**ABM11-143-27.120MHz**

## PART IDENTIFICATION AND ORDERING INFORMATION

ABM11-143-27.120MHZ-



PACKAGING
Blank: Bulk
T3: 3K/Reel

## MECHANICAL DIMENSIONS (ALL DIMENSIONS ARE IN MM)

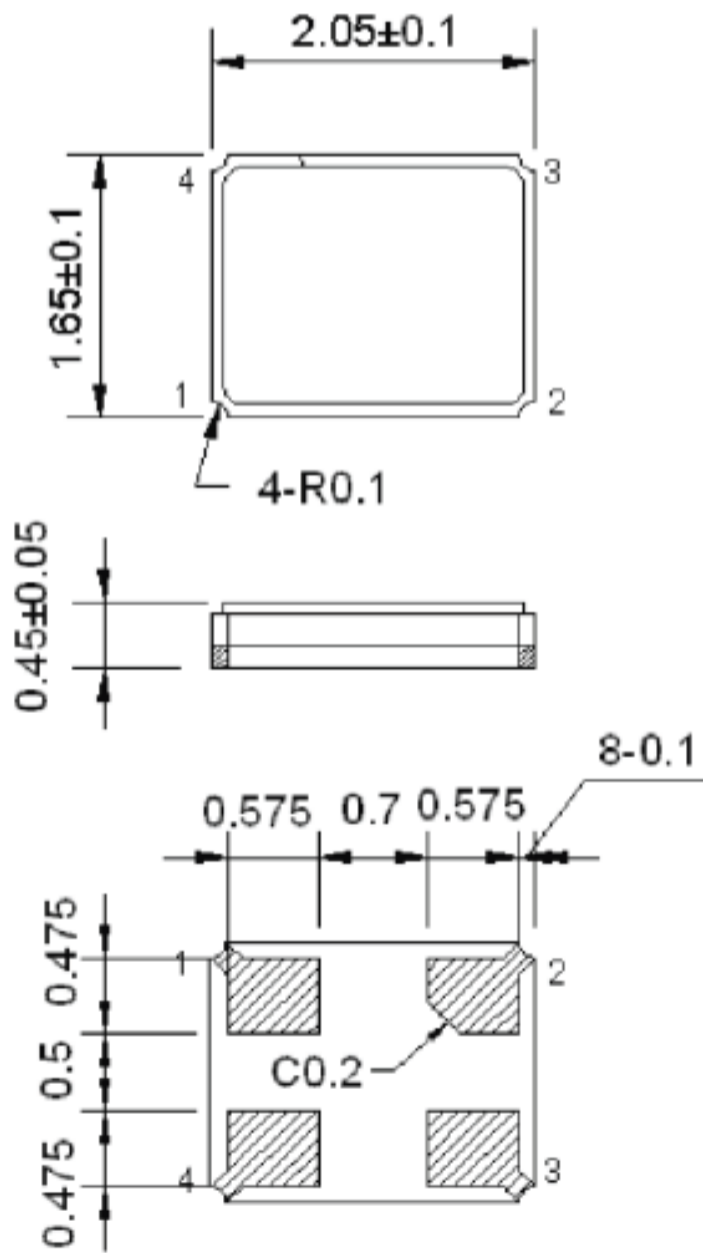

## RECOMMENDED LAND PATTERN

<Top View>

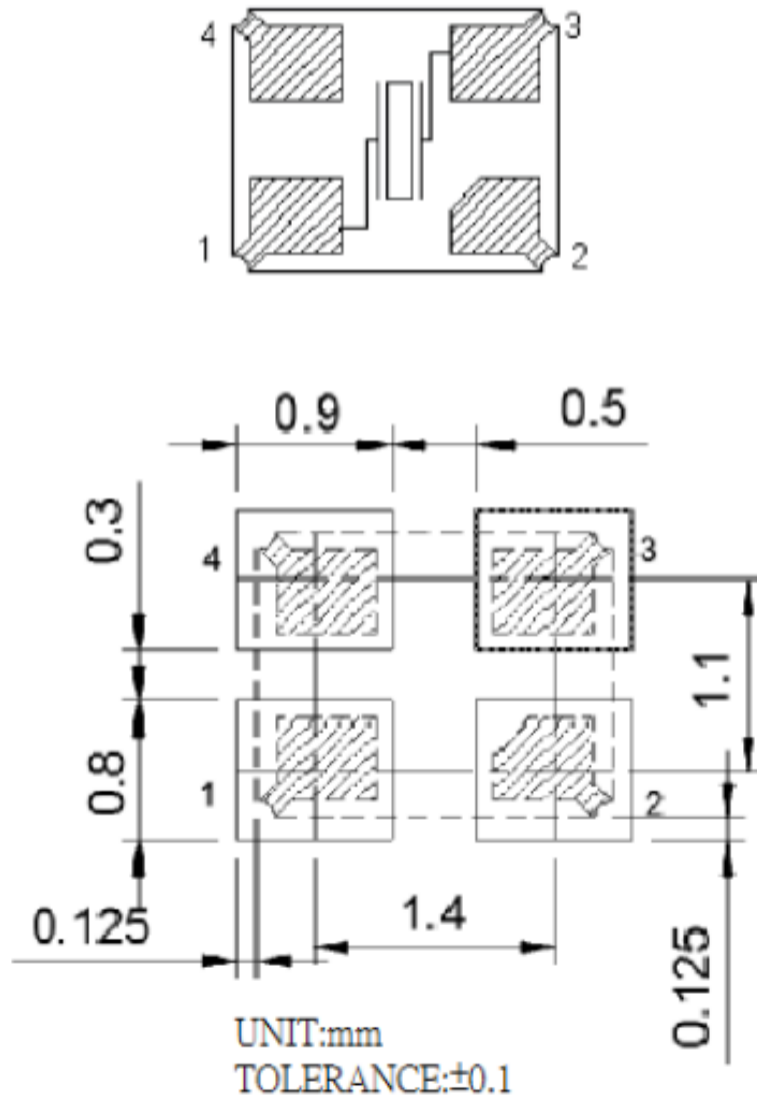

# IoT OPTIMIZED LOW PROFILE QUARTZ CRYSTAL



2.0 x 1.6 x 0.50 mm

**Pb** RoHS/RoHS II Compliant

MSL = N/A: NOT APPLICABLE (See Note #1)

**ABM11-143-27.120MHz**

## REFLOW PROFILE

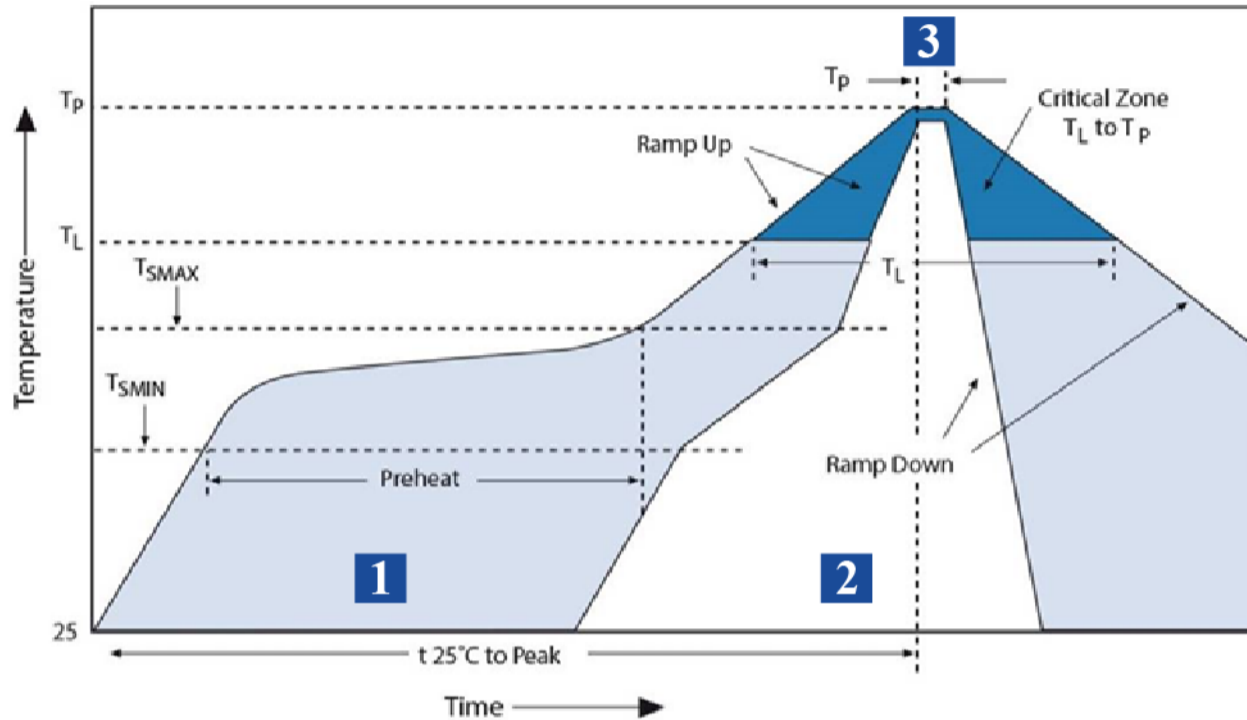

Zone	Description	Temperature	Time
1	Preheat	$T_{SMIN} - T_{SMAX}$ 160°C~180°C	120 sec.
2	Reflow	$T_L$ 60°C	60 sec.
3	Peak Heat	$T_p$ 260°C	10 sec. MAX

## PACKAGING

**T3: 3000PCS/REEL**

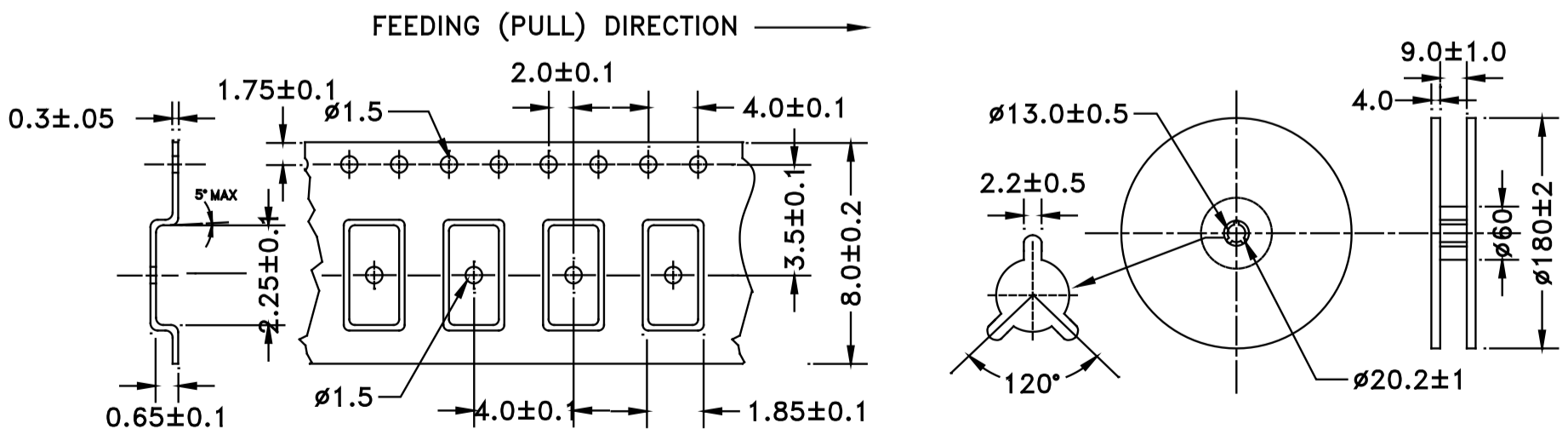

REVISED: 06/21/2016



5101 Hidden Creek Lane Spicewood TX 78669  
 Phone: 512-371-6159 | Fax: 512-351-8858  
 For terms and conditions of sale visit:  
[www.abracon.com](http://www.abracon.com)

ABRACON IS  
 ISO9001-2008  
 CERTIFIED

## X-ON Electronics

Largest Supplier of Electrical and Electronic Components

*Click to view similar products for [Crystals](#) category:*

*Click to view products by [ABRACON](#) manufacturer:*

Other Similar products are found below :

[MC405 32.0000K-R3:PURE SN](#) [7B-27.000MBBK-T](#) [MP1-8.0 99-BU](#) [9B-15.360MBBK-B](#) [PTX-A2JM-10.000M](#) [9C-7.680MBBK-T](#) [H10S-12.000-18-EXT-TR](#) [R38-32.768-12.5-5PPM-NPB](#) [BTD1062E05A-513](#) [21U15A-21.4MHZ](#) [RTX-781DF1-S-20.950](#) [LFXTAL066198Cutt](#) [9C-14.31818MBBK-T](#) [A-11.000MHZ-27](#) [SPT2A-.032768B](#) [SPT2A.032768G](#) [SSPT7F-9PF20-R](#) [FX325BS-38.88EEM1201](#) [MP-1-25.000MHZ-3L](#) [MP-1-6.000MHZ](#) [LFXTAL065253Cutt](#) [LFXTAL066431Cutt](#) [XT9S20ANA14M7456](#) [XT9SNLANA16M](#) [646G-24-2](#) [7B-30.000MBBK-T](#) [6504-202-1501](#) [6526-202-1501](#) [BTJ120E02C](#) [SG636PCE-20.000MC](#) [3404](#) [C1E-24.000-7-2020-R](#) [C1E-19.200-12-1530-X-R](#) [C1E-16.000-12-1530-X-R](#) [FL5000014](#) [EUCA18-3.1872M](#) [425F35E027M0000](#) [17196](#) [MS3V-T1R-32.768kHz-7pF-20PPM-TA-QC-Au](#) [VXM7-1C1-16M000](#) [MS1V-T1K-32.768kHz-10pF-20PPM-TA-QC-Au](#) [MS1V-T1K-32.768kHz-12.5pF-20PPM-TA-QC-Au](#) [MS3V-T1R-32.768kHz-9pF-20PPM-TA-QC-Au](#) [17000](#) [17301](#) [16875](#) [ECS-80-18-30B-JEM-TR](#) [ECS-100-10-30B-CKL-TR](#) [MS1V-T1K-32.768kHz-6pF-20PPM-TA-QC-Au](#)