

ABS07-120-32.768kHz-T; TUNING FORK CRYSTAL



3.2 x 1.5 x 0.9 mm

32.768kHz SMD; ESR OPTIMIZED CRYSTAL



Moisture Sensitivity Level (MSL) – This product is Hermetically Sealed and not Moisture Sensitive - MSL = N/A: Not Applicable

FEATURES:

- Guaranteed ESR of 60kΩ Maximum for Low Power Designs
- 0.9mm height ideal for high density circuit boards
- Seam sealed ceramic package offers excellent environmental & heat resistance
- Extended Operating temperature of -40°C to +85°C for industrial applications

APPLICATIONS:

- Power sensitive designs requiring Low ESR Crystal, such as ST-Micro MCU STM32L based solutions
- Communication & measurement equipment
- Commercial, Consumer & Industrial applications
- Wireless communications
- PDA and Smartphone

STANDARD SPECIFICATIONS

Parameters	Minimum	Typical	Maximum	Units	Notes
Frequency		32.768		kHz	
Operation Mode	Tuning Fork				
Operating Temperature	-40		+85	°C	
Storage Temperature	-55		+125	°C	
Frequency Tolerance @+25°C	-20		+20	ppm	Tested at 0.1uW
Temperature Coefficient:	-0.045	-0.035		ppm/T ²	
Turn-over temperature:	+20	+25	+30	°C	
Equivalent series resistance (R1)		55	60	kΩ	
Shunt capacitance (C0)			1.60	pF	
Motional capacitance (Cm)		3.0 ~ 6.0		fF	
Load capacitance (CL)		6.0		pF	
Drive Level		0.1	0.5	μW	
Q value	13000				
Aging@25°C±3°C	-3		3	ppm	First year
Insulation Resistance	500			MΩ	@ 100Vdc ± 15V

PART IDENTIFICATION: ABS07-120-32.768 kHz-T

FREQUENCY VARIATION OVER OPERATING TEMPERATURE; RELATIVE TO MEASURED FREQUENCY AT 25°C

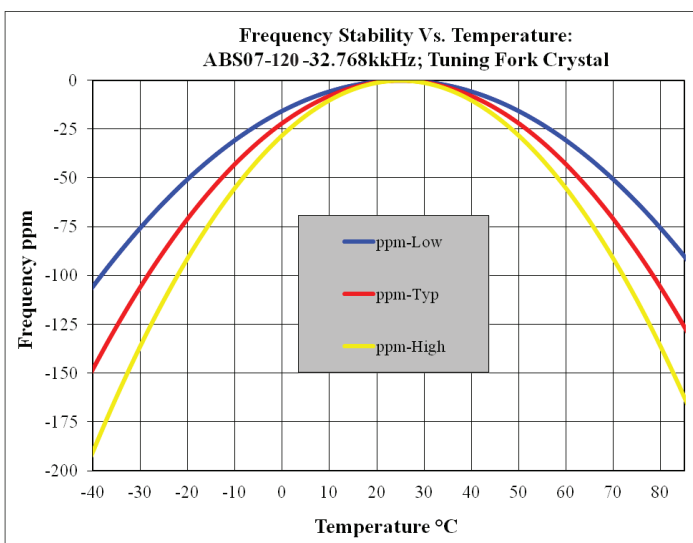

Temp °C	(ppm) Low	(ppm) Typ	(ppm) High
-40	-105.63	-147.88	-190.13
-35	-90.00	-126.00	-162.00
-30	-75.63	-105.88	-136.13
-25	-62.50	-87.50	-112.50
-20	-50.63	-70.88	-91.13
-15	-40.00	-56.00	-72.00
-10	-30.63	-42.88	-55.13
-5	-22.50	-31.50	-40.50
0	-15.63	-21.88	-28.13
5	-10.00	-14.00	-18.00
10	-5.63	-7.88	-10.13
15	-2.50	-3.50	-4.50
20	-0.63	-0.88	-1.13
25	0.00	0.00	0.00
30	-0.63	-0.88	-1.13
35	-2.50	-3.50	-4.50
40	-5.63	-7.88	-10.13
45	-10.00	-14.00	-18.00
50	-15.63	-21.88	-28.13
55	-22.50	-31.50	-40.50
60	-30.63	-42.88	-55.13
65	-40.00	-56.00	-72.00
70	-50.63	-70.88	-91.13
75	-62.50	-87.50	-112.50
80	-75.63	-105.88	-136.13
85	-90.00	-126.00	-162.00



5101 Hidden Creek Ln Spicewood TX 78669
 Phone: 512-371-6159 | Fax: 512-351-8858
 For terms and conditions of sales, please visit:
www.abracon.com

REVISED: 05-26-21

ABRACON IS
 ISO9001-2015
 CERTIFIED

ABS07-120-32.768kHz-T; TUNING FORK CRYSTAL

32.768kHz SMD; ESR OPTIMIZED CRYSTAL

 RoHS/RoHS II



3.2 x 1.5 x 0.9 mm

OUTLINE DRAWING:

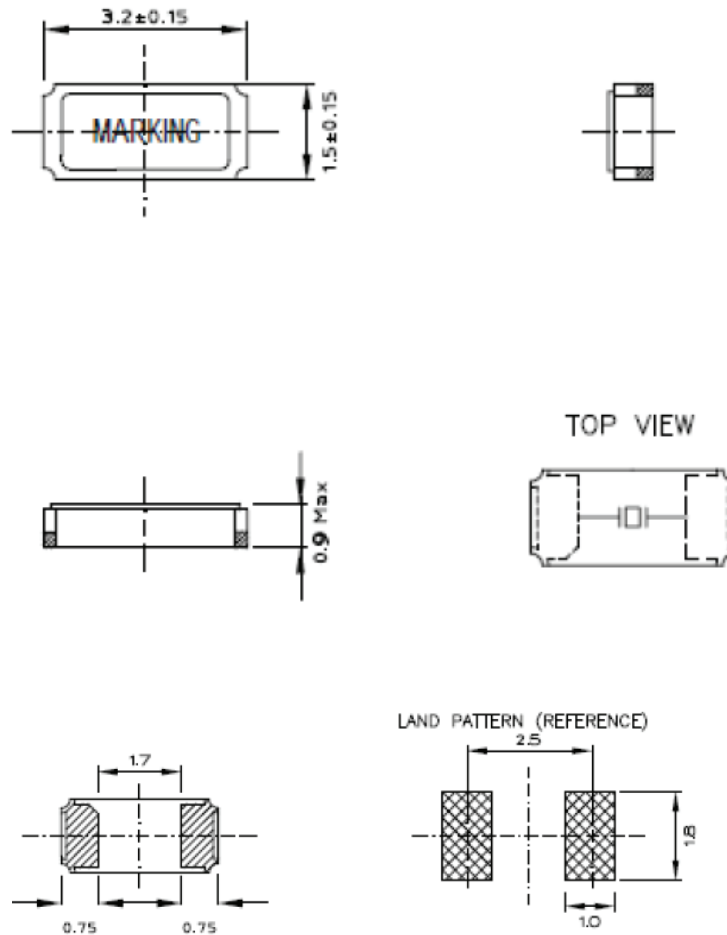

Dimensions: mm

ABS07-120-32.768kHz-T; TUNING FORK CRYSTAL

32.768kHz SMD; ESR OPTIMIZED CRYSTAL



3.2 x 1.5 x 0.9 mm

Reflow Profile [JEDEC J-STD-020]

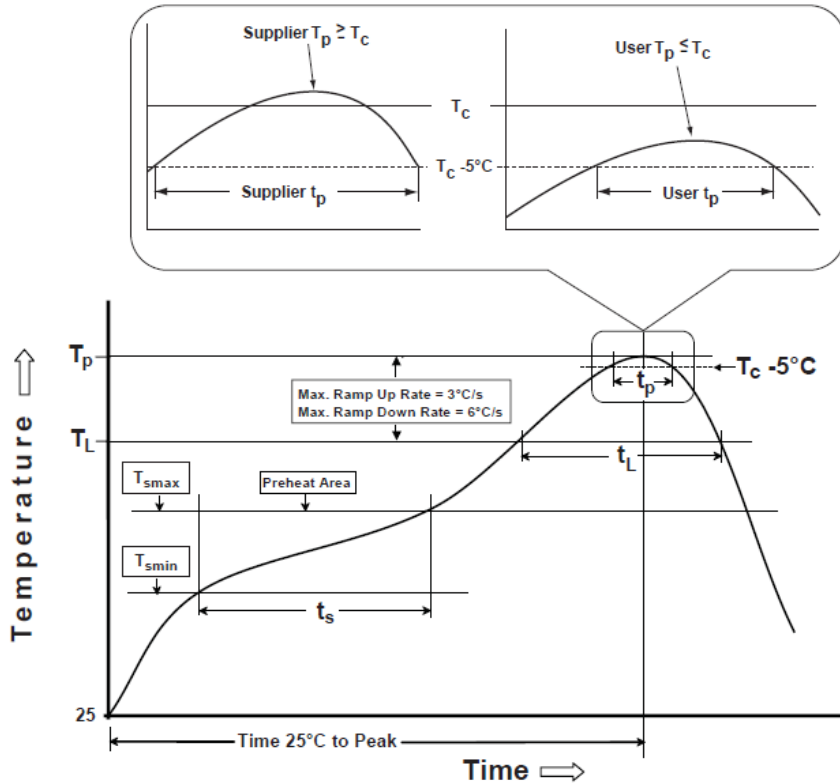

Table 1

SnPb Eutectic Process Classification Temperatures (T_c)		
Package Thickness	Volume mm^3 <350	Volume mm^3 >350
<2.5 mm	235 °C	220 °C
>2.5 mm	220 °C	220 °C

Table 2

Pb-Free Process Classification Temperatures (T_c)			
Package Thickness	Volume mm^3 <350	Volume mm^3 350-2000	Volume mm^3 >2000
<1.6 mm	260 °C	260 °C	260 °C
1.6 mm - 2.5 mm	260 °C	250 °C	245 °C
>2.5 mm	250 °C	245 °C	245 °C

Profile Feature	Sn-Pb Eutectic Assembly	Pb-Free Assembly
Preheat / soak		
Temperature minimum (T_{smin})	100°C	150°C
Temperature maximum (T_{smax})	150°C	200°C
Time (T_{smin} to T_{smax}) (t_s)	60 - 120 sec.	60 - 120 sec.
Average ramp-up rate (T_{smax} to T_p)	3°C/sec. max	3°C/sec. max
Liquidous temperature (T_L)	183°C	217°C
Time at liquidous (t_L)	60 - 150 sec.	60 - 150 sec.
Peak package body temperature (T_p)*	see Table 1	see Table 2
Time (t_p)** within 5°C of the specified classification temperature (T_c)	20 sec.	30 sec.
Ramp-down rate (T_p to T_{smax})	6°C/sec. max	6°C/sec. max
Time 25°C to peak temperature	6 min. max	8 min. max
Reflow cycles	2 max	2 max

*Tolerance for peak profile temperature (T_p) is defined as a supplier minimum and a user maximum.

**Tolerance for time at peak profile temperature (t_p) is defined as supplier minimum and a user maximum.

ABS07-120-32.768kHz-T; TUNING FORK CRYSTAL

32.768kHz SMD; ESR OPTIMIZED CRYSTAL



3.2 x 1.5 x 0.9 mm

TAPE & REEL:

T=Tape and reel (3,000pcs/reel)
T9=Tape and reel (9,000pcs/reel)

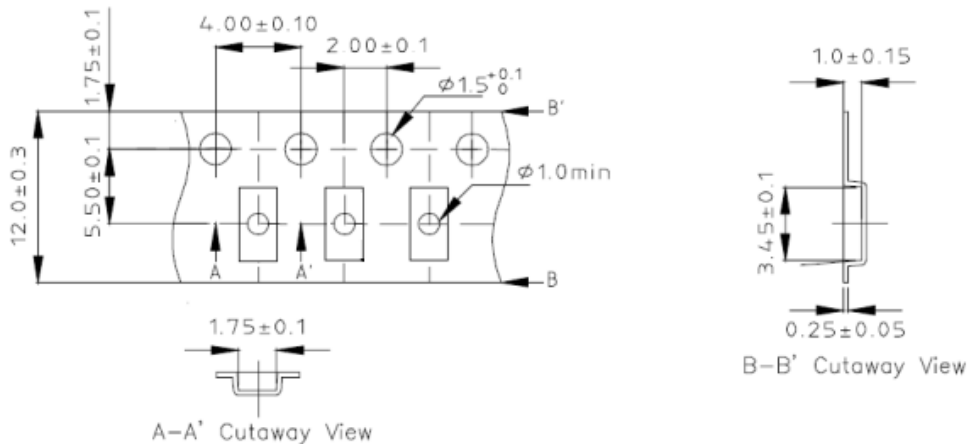

Reel=3,000pcs

REEL : 3000PCS

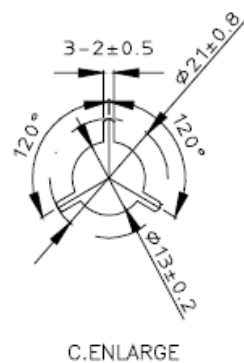
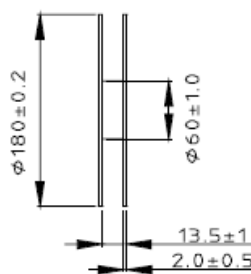
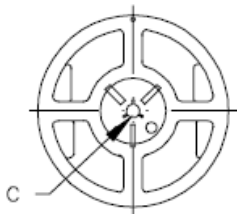

Reel=9,000pcs

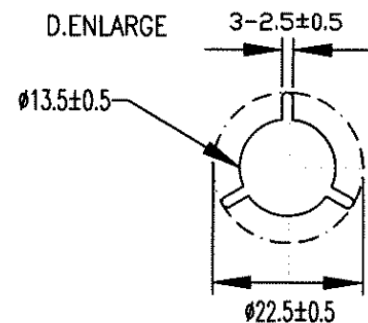
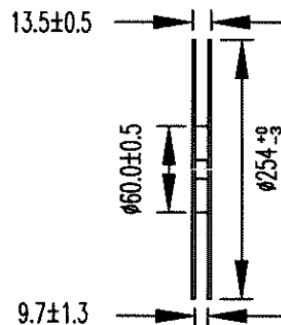
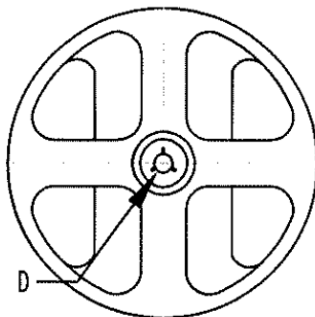

Dimensions: mm

ATTENTION: Abracon LLC's products are COTS – Commercial-Off-The-Shelf products; suitable for Commercial, Industrial and, where designated, Automotive Applications. Abracon's products are not specifically designed for Military, Aviation, Aerospace, Life-dependent Medical applications or any application requiring high reliability where component failure could result in loss of life and/or property. For applications requiring high reliability and/or presenting an extreme operating environment, written consent and authorization from Abracon LLC is required. Please contact Abracon LLC for more information.



5101 Hidden Creek Ln Spicewood TX 78669
Phone: 512-371-6159 | Fax: 512-351-8858
For terms and conditions of sales, please visit:
www.abracon.com

REVISED: 05-26-21

ABRACON IS
ISO9001-2015
CERTIFIED

X-ON Electronics

Largest Supplier of Electrical and Electronic Components

Click to view similar products for [Crystals](#) category:

Click to view products by [ABRACON](#) manufacturer:

Other Similar products are found below :

[MC405 32.0000K-R3:PURE SN](#) [7B-27.000MBBK-T](#) [MP1-8.0 99-BU](#) [9B-15.360MBBK-B](#) [PTX-A2JM-10.000M](#) [9C-7.680MBBK-T](#) [H10S-12.000-18-EXT-TR](#) [R38-32.768-12.5-5PPM-NPB](#) [BTD1062E05A-513](#) [21U15A-21.4MHZ](#) [RTX-781DF1-S-20.950](#) [LFXTAL066198Cutt](#) [9C-14.31818MBBK-T](#) [A-11.000MHZ-27](#) [SPT2A-.032768B](#) [SPT2A.032768G](#) [SSPT7F-9PF20-R](#) [FX325BS-38.88EEM1201](#) [MP-1-25.000MHZ-3L](#) [MP-1-6.000MHZ](#) [LFXTAL065253Cutt](#) [LFXTAL066431Cutt](#) [XT9S20ANA14M7456](#) [XT9SNLANA16M](#) [646G-24-2](#) [7B-30.000MBBK-T](#) [6504-202-1501](#) [6526-202-1501](#) [BTJ120E02C](#) [SG636PCE-20.000MC](#) [3404](#) [C1E-24.000-7-2020-R](#) [C1E-19.200-12-1530-X-R](#) [C1E-16.000-12-1530-X-R](#) [FL5000014](#) [EUCA18-3.1872M](#) [425F35E027M0000](#) [17196](#) [MS3V-T1R-32.768kHz-7pF-20PPM-TA-QC-Au](#) [VXM7-1C1-16M000](#) [MS1V-T1K-32.768kHz-10pF-20PPM-TA-QC-Au](#) [MS1V-T1K-32.768kHz-12.5pF-20PPM-TA-QC-Au](#) [MS3V-T1R-32.768kHz-9pF-20PPM-TA-QC-Au](#) [17000](#) [17301](#) [16875](#) [ECS-80-18-30B-JEM-TR](#) [ECS-100-10-30B-CKL-TR](#) [MS1V-T1K-32.768kHz-6pF-20PPM-TA-QC-Au](#)