

HIGH CURRENT CERAMIC WIRE WOUND INDUCTORS

AISC-0402HP

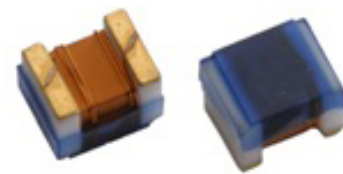

RoHS/RoHS II Compliant



1.00 x 0.55 x 0.50mm

FEATURES:

- Higher Q and lower DCR than other 0402 inductors
- Very high SRF – as high as 8.5 GHz
- Excellent current handling capability – up to 2100mA
- Wide range of Inductance values available for flexible needs
- Tight tolerance of 2% is available.

APPLICATIONS:

- Widely used in communications applications such as cell phones, cable modems, ADSL, repeaters.
- Bluetooth, W-LAN, GPS, Broadband Network
- Video cameras, liquid crystal television, and other electronic devices
- Suitable for RF circuit

ELECTRICAL SPECIFICATIONS:

PARAMETERS

ABRACON P/N:	AISC-0402HP Series
Operating temperature:	-40°C to + 125°C in Tape & Reel
Storage temperature:	-10°C to +40°C, 20% to 70% RH

Part Number AISC-0402HP- Inductance Code	Inductance	Tolerance	Min. Quality Factor	L/Q Test Freq.	Max. DC Resistance	Max. Rated Current	Min. Self-resonant Frequency
Units	nH	-	-	MHz	Ω	mA	MHz
Symbol	L	-	Q	Freq.	DCR	I _r	S.R.F
AISC-0402HP-2N0	2.0	B, S	22	250	0.038	2100	8500
AISC-0402HP-2N2	2.2	B, S	22	250	0.038	2100	8500
AISC-0402HP-2N7	2.7	B, S	22	250	0.056	1500	8500
AISC-0402HP-3N3	3.3	K, J, B	23	250	0.045	1700	8500
AISC-0402HP-3N6	3.6	K, J, B	23	250	0.045	1700	8500
AISC-0402HP-3N9	3.9	K, J, B	23	250	0.045	1700	8500
AISC-0402HP-4N3	4.3	K, J, B	22	250	0.055	1500	7150
AISC-0402HP-4N7	4.7	K, J, B	20	250	0.075	1400	6850
AISC-0402HP-5N1	5.1	K, J, B	23	250	0.085	1300	6800
AISC-0402HP-5N6	5.6	K, J, B	23	250	0.055	1500	6500
AISC-0402HP-6N2	6.2	K, J, B	25	250	0.065	1400	5800
AISC-0402HP-6N8	6.8	K, J, B	25	250	0.065	1400	5800
AISC-0402HP-7N5	7.5	K, J, B	25	250	0.080	1400	5400
AISC-0402HP-8N2	8.2	K, J, B	25	250	0.085	1300	5400
AISC-0402HP-8N7	8.7	K, J, B	25	250	0.085	1300	5000
AISC-0402HP-9N0	9.0	K, J, B	25	250	0.085	1300	5000
AISC-0402HP-9N5	9.5	K, J, B	25	250	0.095	1200	4700
AISC-0402HP-10N	10	K, J, G	25	250	0.085	1300	4700
AISC-0402HP-11N	11	K, J, G	25	250	0.090	1300	4700
AISC-0402HP-12N	12	K, J, G	26	250	0.090	1100	4400
AISC-0402HP-13N	13	K, J, G	25	250	0.140	900	4200
AISC-0402HP-15N	15	K, J, G	26	250	0.130	1000	3900
AISC-0402HP-16N	16	K, J, G	26	250	0.130	850	3700
AISC-0402HP-18N	18	K, J, G	26	250	0.140	850	3550
AISC-0402HP-19N	19	K, J, G	26	250	0.145	850	3500
AISC-0402HP-20N	20	K, J, G	26	250	0.155	800	3500
AISC-0402HP-21N	21	K, J, G	26	250	0.160	800	3300
AISC-0402HP-22N	22	K, J, G	26	250	0.160	800	3300
AISC-0402HP-23N	23	K, J, G	26	250	0.190	700	3300
AISC-0402HP-24N	24	K, J, G	26	250	0.180	650	3150
AISC-0402HP-25N	25	K, J, G	25	250	0.180	650	3150
AISC-0402HP-26N	26	K, J, G	25	250	0.170	700	3150
AISC-0402HP-27N	27	K, J, G	26	250	0.220	600	3200
AISC-0402HP-30N	30	K, J, G	25	250	0.275	500	2900
AISC-0402HP-33N	33	K, J, G	25	250	0.320	490	2800
AISC-0402HP-36N	36	K, J, G	26	250	0.360	480	2800

ABRACON IS
ISO 9001:2008
CERTIFIED



ABRACON
CORPORATION

Visit www.abracon.com for Terms & Conditions of Sale

30332 Esperanza, Rancho Santa Margarita, California 92688
tel 949-546-8000 fax 949-546-8001 www.abracon.com

Revised: 04.06.13

HIGH CURRENT CERAMIC WIRE WOUND INDUCTORS

AISC-0402HP



RoHS/RoHS II Compliant

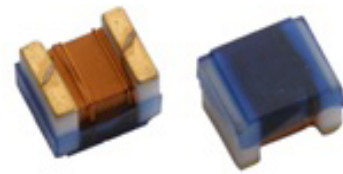

1.00 x 0.55 x 0.50mm

Part Number AISC-0402HP- Inductance Code	Inductance	Tolerance	Min. Quality Factor	L/Q Test Freq.	Max. DC Resistance	Max. Rated Current	Min. Self-resonant Frequency
Units	nH	-	-	MHz	Ω	mA	MHz
Symbol	L	-	Q	Freq.	DCR	Ir	S.R.F
AISC-0402HP-37N	37	K, J, G	25	250	0.430	470	2700
AISC-0402HP-39N	39	K, J, G	25	250	0.430	450	2600
AISC-0402HP-40N	40	K, J, G	26	250	0.430	450	2600
AISC-0402HP-43N	43	K, J, G	26	250	0.500	450	2500
AISC-0402HP-47N	47	K, J, G	22	200	0.550	420	2400
AISC-0402HP-51N	51	K, J	22	200	0.750	360	2300
AISC-0402HP-56N	56	K, J	22	200	0.850	330	2070
AISC-0402HP-68N	68	K, J	22	200	0.950	320	1840

Test Conditions

1. Inductance is measured in HP-4287A RF LCR meter with HP-16193 fixture.
2. SRF is measured in ENA E5071B network analyzer
3. RDC is measured in HP-4338B milliohmeter.
4. Definition of Rated Current (Ir): Ir is direct electric current as chip surface temperature rose just 25°C against chip initial surface temperature (Ta)

PART NUMBER IDENTIFICATION

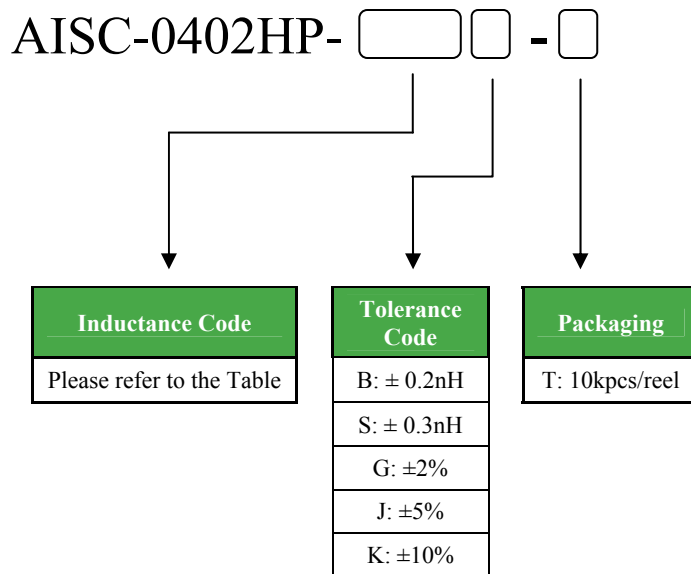

HIGH CURRENT CERAMIC WIRE WOUND INDUCTORS

AISC-0402HP

 RoHS/RoHS II Compliant

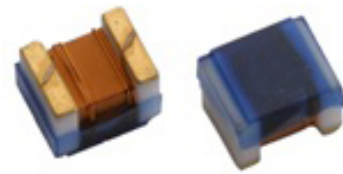

1.00 x 0.55 x 0.50mm

OUTLINE DIMENSIONS

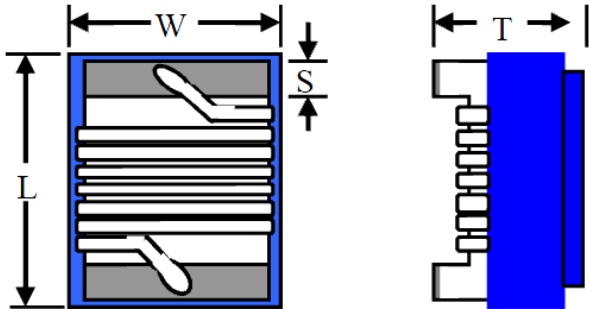

L	W	T	S
1.00 ± 0.10	0.55 ± 0.10	0.50 ± 0.10	0.20 ± 0.10

Recommended Land Pattern

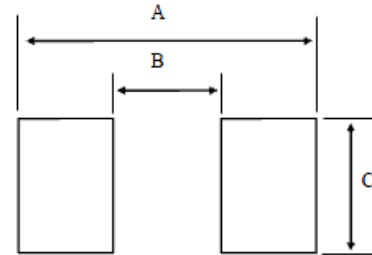

A	B	C
1.20	0.45	0.65

Dimension: mm

ELECTRODE MATERIALS

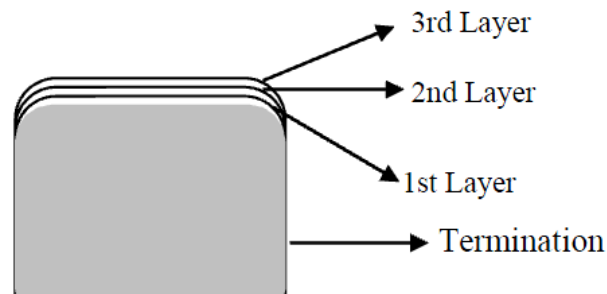

Components	Material
1 st Layer	Mo/Mn
2 nd Layer	Nickel
3 rd Layer	Au

HIGH CURRENT CERAMIC WIRE WOUND INDUCTORS

AISC-0402HP



RoHS/RoHS II Compliant

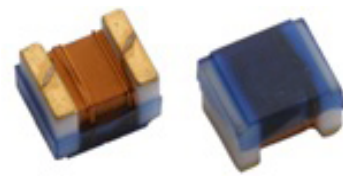

1.00 x 0.55 x 0.50mm

REFLOW PROFILE

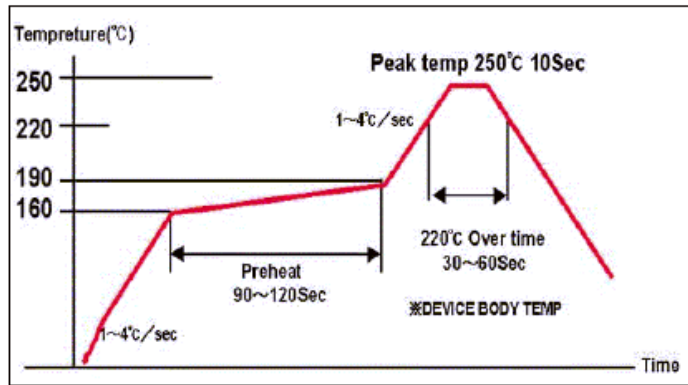

TAPE & REEL:

T= tape and reel (10,000pcs/reel)

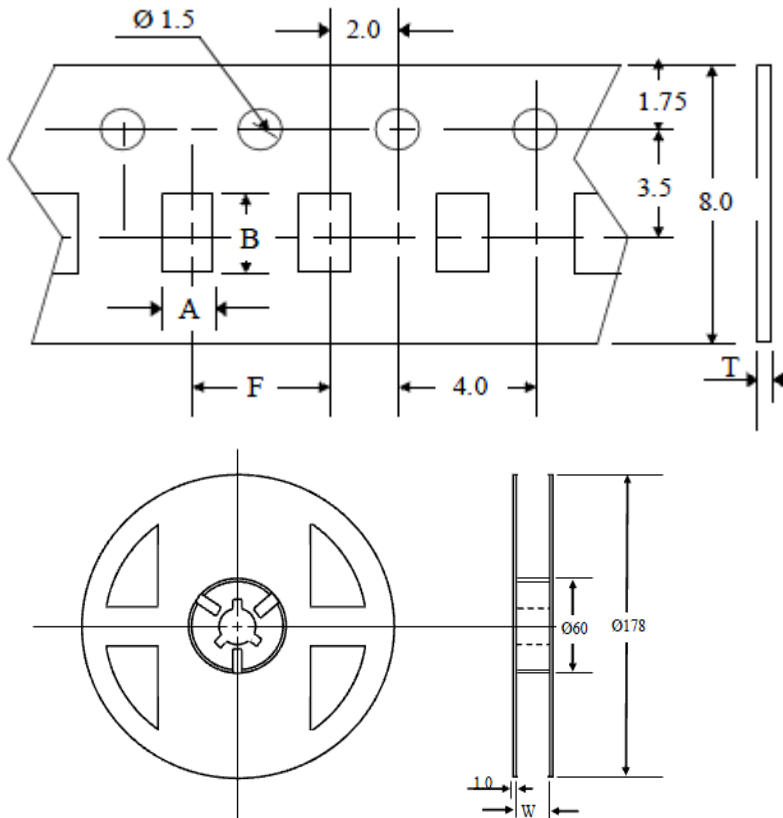

A	B	F	T	W
0.70	1.20	2.00	0.70	8.00

Dimension: mm

Storage period

Use the product within 12 months after delivered. Solderability should be checked if this period is exceeded.

ATTENTION: Abracon Corporation's products are COTS – Commercial-Off-The-Shelf products; suitable for Commercial, Industrial and, where designated, Automotive Applications. Abracon's products are not specifically designed for Military, Aviation, Aerospace, Life-dependant Medical applications or any application requiring high reliability where component failure could result in loss of life and/or property. For applications requiring high reliability and/or presenting an extreme operating environment, written consent and authorization from Abracon Corporation is required. Please contact Abracon Corporation for more information.

ABRACON IS
ISO 9001:2008
CERTIFIED



Visit www.abracon.com for Terms & Conditions of Sale
30332 Esperanza, Rancho Santa Margarita, California 92688
tel 949-546-8000 fax 949-546-8001 www.abracon.com

Revised: 04.06.13

X-ON Electronics

Largest Supplier of Electrical and Electronic Components

Click to view similar products for [Multilayer Ceramic Capacitors MLCC - SMD/SMT](#) category:

Click to view products by [ABRACON](#) manufacturer:

Other Similar products are found below :

[M39014/01-1467](#) [M39014/02-1218V](#) [M39014/02-1225V](#) [M39014/02-1262V](#) [M39014/02-1301](#) [M39014/22-0631](#) [1210J5000102JCT](#)
[1210J2K00102KXT](#) [1210J5000103KXT](#) [1210J5000223KXT](#) [D55342E07B379BR-TR](#) [D55342E07B523DR-T/R](#) [1812J1K00103KXT](#)
[1812J1K00473KXT](#) [1812J2K00680JCT](#) [1812J4K00102MXT](#) [1812J5000102JCT](#) [1812J5000103JCT](#) [1812J5000682JCT](#) [NIN-FB391JTRF](#)
[NIN-FC2R7JTRF](#) [NPIS27H102MTRF](#) [C1206C101J1GAC](#) [C1608C0G1E472JT000N](#) [C2012C0G2A472J](#) [2220J2K00101JCT](#)
[KHC201E225M76N0T00](#) [LRC-LRF1206LF-01R025FTR1K](#) [1812J1K00222JCT](#) [1812J2K00102KXT](#) [1812J2K00222KXT](#)
[1812J2K00472KXT](#) [2-1622820-7-CUT-TAPE](#) [2220J3K00102KXT](#) [2225J2500824KXT](#) [CCR07CG103KM](#) [CGA2B2C0G1H010C](#)
[CGA2B2C0G1H040C](#) [CGA2B2C0G1H050C](#) [CGA2B2C0G1H060D](#) [CGA2B2C0G1H070D](#) [CGA2B2C0G1H151J](#) [CGA2B2C0G1H1R5C](#)
[CGA2B2C0G1H2R2C](#) [CGA2B2C0G1H3R3C](#) [CGA2B2C0G1H680J](#) [CGA2B2C0G1H6R8D](#) [CGA2B2X8R1H221K](#) [CGA2B2X8R1H472K](#)
[CGA3E1X7R1C474K](#)