

# High Q Ceramic Wirewound RF Inductor (AEC-Q200)



**AISC-Q0402HQ Series**

Request Samples



Check Inventory



1.27 x 0.76 x 0.61 mm  
**RoHS/RoHS II Compliant**  
 MSL Level = 1

## Features

- PPAP ready and supported
- TS16949 certified production lines
- AEC-Q200 (grade 1) qualified
- Ceramic base with high SRF
- Excellent DCR and current carrying characteristics.
- Ultra-compact inductors
- Tight tolerance down to  $\pm 2\%$

## Applications

- Automotive applications
- Bluetooth, W-LAN, Broadband Network
- Impedance matching networks
- Filtering for high frequency communication circuits
- Video cameras, displays, and other electronic devices.

## Electrical Specifications

Part Number	Inductance	Tolerance	Min. Quality Factor		L/Q Test Freq.	Max. DC Resistance	Max. Rated Current	Min. Self-resonant Frequency
Units	nH	-	Q		MHz	$\Omega$	mA	GHz
Symbol	L	-	900MHz	1.7GHz	Freq.	DCR	Ir	S.R.F
AISC-Q0402HQ-1N0	1.0	C, D, J, K	46	75	250	0.030	2300	16.0
AISC-Q0402HQ-2N0	2.0	C, D, J, K	58	85	250	0.038	2100	15.2
AISC-Q0402HQ-2N2	2.2	C, D, J, K	60	86	250	0.038	2100	15.1
AISC-Q0402HQ-2N4	2.4	C, D, J, K	60	83	250	0.042	2000	14.0
AISC-Q0402HQ-2N7	2.7	C, D, J, K	62	85	250	0.075	1500	13.0
AISC-Q0402HQ-3N3	3.3	C, D, J, K	66	95	250	0.045	1700	12.8
AISC-Q0402HQ-3N6	3.6	C, D, J, K	65	94	250	0.045	1700	11.7
AISC-Q0402HQ-3N9	3.9	C, D, J, K	64	98	250	0.045	1700	9.50
AISC-Q0402HQ-4N3	4.3	D, J, K	63	90	250	0.50	1600	7.15
AISC-Q0402HQ-4N7	4.7	D, J, K	58	83	250	0.70	1500	6.85
AISC-Q0402HQ-5N1	5.1	G, J, K	54	76	250	0.115	1200	6.80
AISC-Q0402HQ-5N6	5.6	G, J, K	73	105	250	0.050	1600	6.50
AISC-Q0402HQ-6N2	6.2	G, J, K	73	100	250	0.055	1600	5.80
AISC-Q0402HQ-6N8	6.8	G, J, K	68	94	250	0.065	1500	5.80
AISC-Q0402HQ-7N5	7.5	G, J, K	60	82	250	0.090	1400	5.40
AISC-Q0402HQ-8N2	8.2	G, J, K	68	95	250	0.065	1500	5.40
AISC-Q0402HQ-8N7	8.7	G, J, K	68	95	250	0.065	1500	5.00
AISC-Q0402HQ-9N0	9.0	G, J, K	67	92	250	0.080	1400	5.00
AISC-Q0402HQ-9N5	9.5	G, J, K	64	90	250	0.090	1400	4.70
AISC-Q0402HQ-10N	10	G, J, K	62	90	250	0.100	1300	4.70
AISC-Q0402HQ-11N	11	G, J, K	68	98	250	0.065	1400	4.70
AISC-Q0402HQ-12N	12	G, J, K	66	100	250	0.100	1200	4.40
AISC-Q0402HQ-13N	13	G, J, K	62	82	250	0.150	870	4.20
AISC-Q0402HQ-15N	15	G, J, K	62	85	250	0.110	1100	3.90
AISC-Q0402HQ-16N	16	G, J, K	57	77	250	0.140	850	3.70



5101 Hidden Creek Ln, Spicewood TX 78669  
 Phone: 512-371-6159 Fax: 512-351-8858  
 For terms and conditions of sales, please visit:  
[www.abracon.com](http://www.abracon.com)

**REVISION Initial Release :**  
**11/21/2023**

ABRACON IS  
 ISO9001-2015  
 CERTIFIED

# High Q Ceramic Wirewound RF Inductor (AEC-Q200)



AISC-Q0402HQ Series

Request Samples



Check Inventory



1.27 x 0.76 x 0.61 mm  
RoHS/RoHS II Compliant  
MSL Level = 1

## Electrical Specifications (Cont'd)

Part Number	Inductance	Tolerance	Min. Quality Factor		L/Q Test Freq.	Max. DC Resistance	Max. Rated Current	Min. Self-resonant Frequency
Units	nH	-	Q		MHz	$\Omega$	mA	GHz
Symbol	L	-	900MHz	1.7GHz	Freq.	DCR	Ir	S.R.F
AISC-Q0402HQ-18N	18	G, J, K	58	74	250	0.120	900	3.55
AISC-Q0402HQ-19N	19	G, J, K	61	88	250	0.145	850	3.50
AISC-Q0402HQ-20N	20	G, J, K	58	76	250	0.185	780	3.50
AISC-Q0402HQ-21N	21	G, J, K	48	62	250	0.460	450	1.70
AISC-Q0402HQ-22N	22	G, J, K	60	74	250	0.160	800	3.30
AISC-Q0402HQ-23N	23	G, J, K	60	77	250	0.160	800	3.30
AISC-Q0402HQ-24N	24	G, J, K	55	71	250	0.200	700	3.15
AISC-Q0402HQ-25N	25	G, J, K	57	73	250	0.250	600	3.15
AISC-Q0402HQ-26N	26	G, J, K	56	74	250	0.285	450	3.15
AISC-Q0402HQ-27N	27	G, J, K	62	86	250	0.320	450	3.20
AISC-Q0402HQ-30N	30	G, J, K	61	87	250	0.330	450	2.90
AISC-Q0402HQ-33N	33	G, J, K	61	80	250	0.330	490	2.80
AISC-Q0402HQ-36N	36	G, J, K	59	76	250	0.380	480	2.80
AISC-Q0402HQ-37N	37	G, J, K	57	72	250	0.460	470	2.70
AISC-Q0402HQ-39N	39	G, J, K	56	84	250	0.430	450	2.60
AISC-Q0402HQ-40N	40	G, J, K	56	75	250	0.430	450	2.60
AISC-Q0402HQ-43N	43	G, J, K	52	68	250	0.520	450	2.50
AISC-Q0402HQ-47N	47	G, J, K	48	62	250	0.580	420	2.40
AISC-Q0402HQ-51N	51	G, J, K	52	59	250	0.700	360	2.30

### Test Conditions:

Inductance, Q: HP4286/E4982A

SRF: HP4287/E4982A

DCR: Micro-Ohm meter (Gom-801G)/E4982A

IDC: Applied the current to coils, the temperature of coil increases  $\Delta T 15^{\circ}\text{C}$  ( $T_a = 25^{\circ}\text{C}$ ).

**Operating Temperature:**  $-40^{\circ}\text{C}$  to  $+125^{\circ}\text{C}$

**Components Storage Temperature:**  $-40^{\circ}\text{C}$  to  $+125^{\circ}\text{C}$

**Tape and Reel packaging Temperature:**  $15\sim 28^{\circ}\text{C}$ ;  $< 80\%$  RH

AISC-Q0402HQ is AEC-Q200 Qualified

AISC-Q0402HQ Series is **RoHS Compliant and Pb free**



5101 Hidden Creek Ln, Spicewood TX 78669  
Phone: 512-371-6159 Fax: 512-351-8858  
For terms and conditions of sales, please visit:  
[www.abracon.com](http://www.abracon.com)

**REVISION Initial Release :**  
**11/21/2023**

ABRACON IS  
ISO9001-2015  
CERTIFIED

# High Q Ceramic Wirewound RF Inductor (AEC-Q200)



**AISC-Q0402HQ Series**

Request Samples



Check Inventory



1.27 x 0.76 x 0.61 mm  
**RoHS/RoHS II Compliant**  
 MSL Level = 1

## Part Number Identification

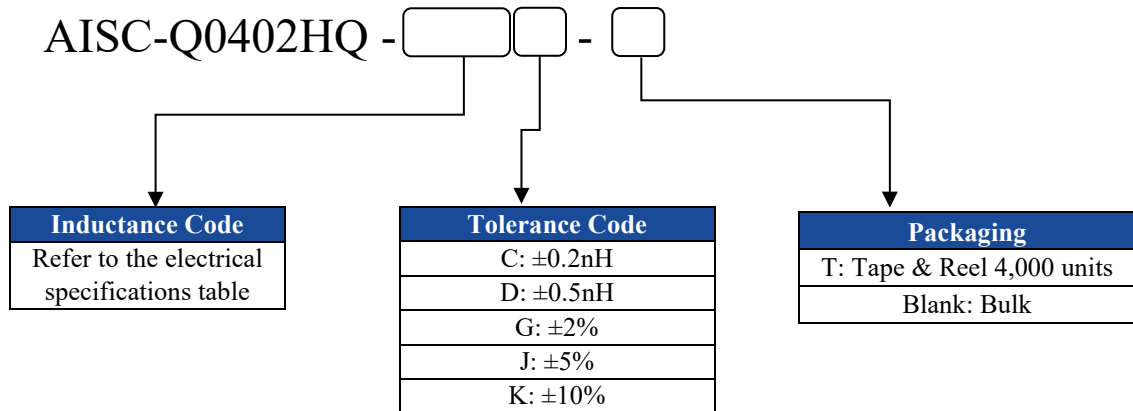

## Mechanical Dimensions

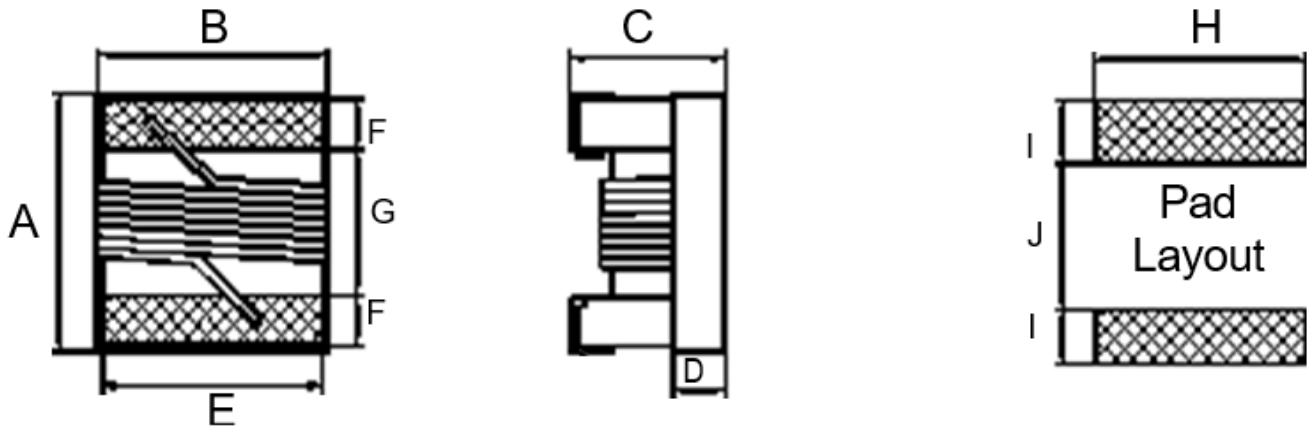

A	B	C	D	E	F	G	H	I	J
1.27 max	0.76 max	0.61 max	0.15 max	0.51	0.23	0.56	0.66	0.5	0.46

Dimensions: mm



5101 Hidden Creek Ln, Spicewood TX 78669  
 Phone: 512-371-6159 Fax: 512-351-8858  
 For terms and conditions of sales, please visit:  
[www.abracon.com](http://www.abracon.com)

**REVISION Initial Release :**  
 11/21/2023

ABRACON IS  
 ISO9001-2015  
 CERTIFIED

# High Q Ceramic Wirewound RF Inductor (AEC-Q200)



AISC-Q0402HQ Series

Request Samples



Check Inventory



1.27 x 0.76 x 0.61 mm  
 RoHS/RoHS II Compliant  
 MSL Level = 1

## Reflow Profile

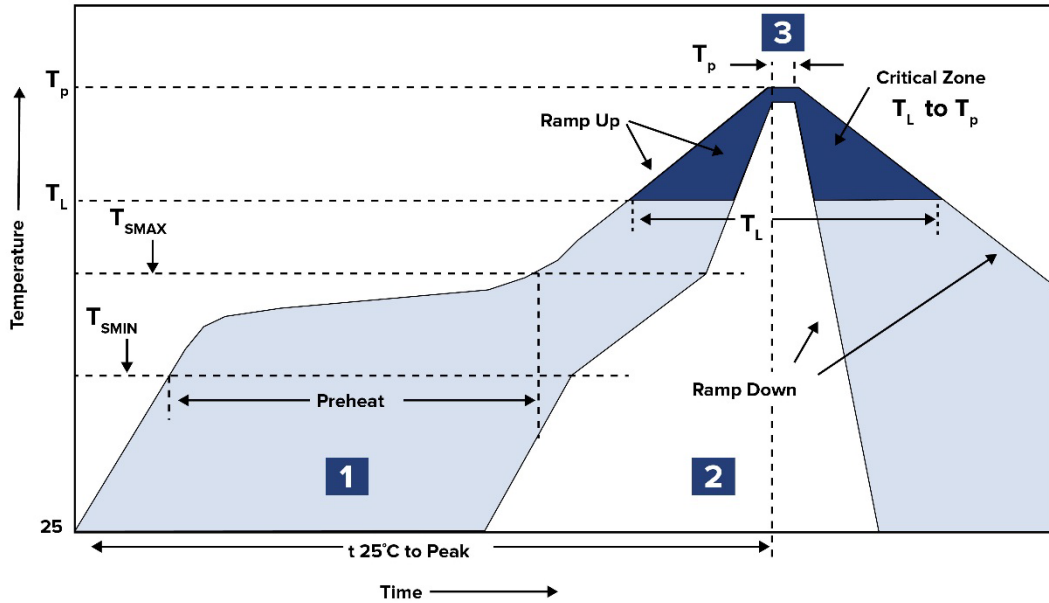

Zone	Description	Temperature	Times
1	Preheat	$T_{SMIN} \sim T_{SMAX}$ 150°C ~ 180°C	90 ~ 120 sec.
2	Reflow	$T_L$ 220°C	40 ~ 60 sec.
3	Peak heat	$T_P$ 260°C±5°C	10 sec. MAX

# High Q Ceramic Wirewound RF Inductor (AEC-Q200)



AISC-Q0402HQ Series

Request Samples



Check Inventory



1.27 x 0.76 x 0.61 mm  
 RoHS/RoHS II Compliant  
 MSL Level = 1

## Packaging

T: Tape & Reel: 4,000 pcs/reel

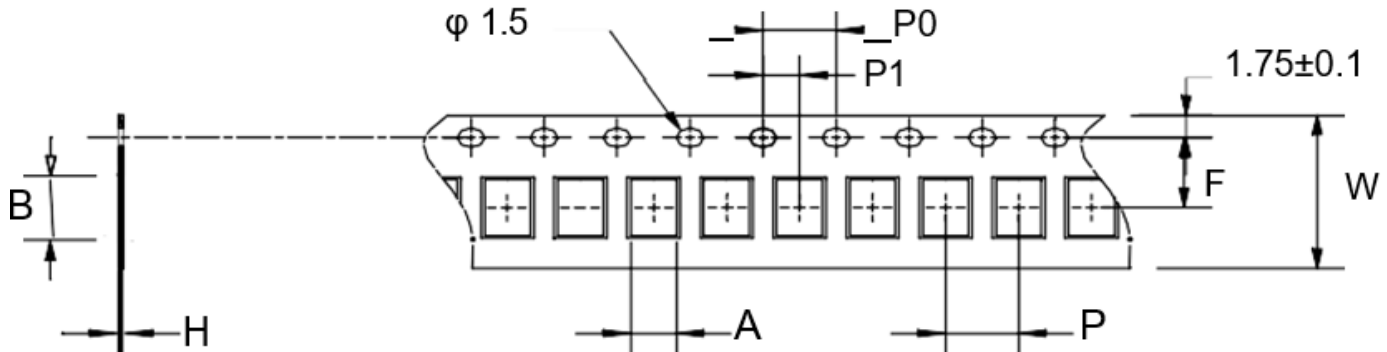

A	B	H	F	P	P0	P1	W
0.81	1.23	0.73	3.50	2.0	4.0	2.0	8.0

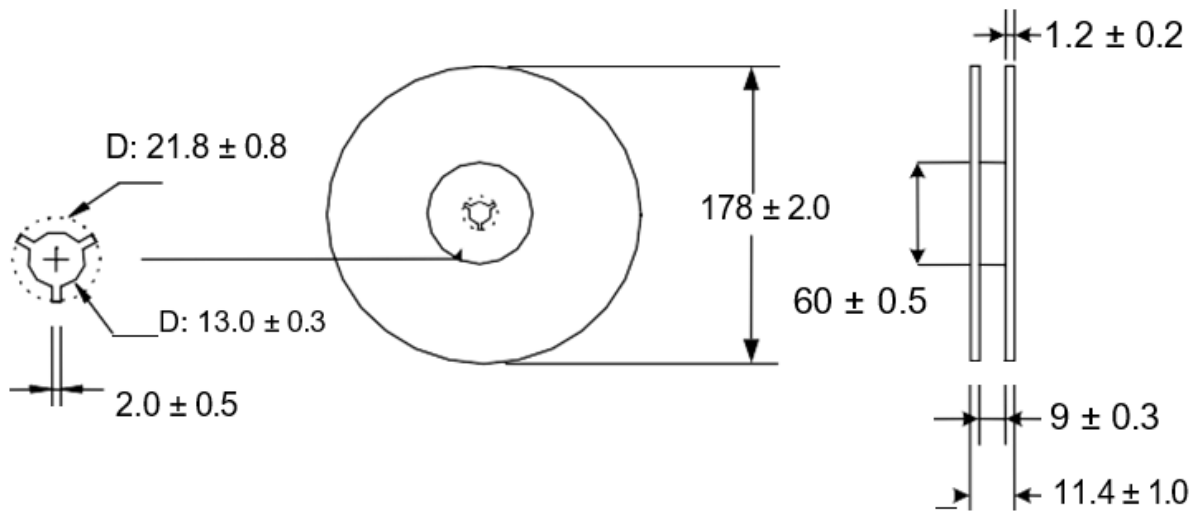

Dimensions: mm

**ATTENTION:** Abracon LLC's products are COTS – Commercial-Off-The-Shelf products; suitable for Commercial, Industrial and, where designated, Automotive Applications. Abracon's products are not specifically designed for Military, Aviation, Aerospace, Life-dependent Medical applications or any application requiring high reliability where component failure could result in loss of life and/or property. For applications requiring high reliability and/or presenting an extreme operating environment, written consent and authorization from Abracon LLC is required. Please contact Abracon LLC for more information.



5101 Hidden Creek Ln, Spicewood TX 78669  
 Phone: 512-371-6159 Fax: 512-351-8858  
 For terms and conditions of sales, please visit:  
[www.abracon.com](http://www.abracon.com)

REVISION Initial Release :  
 11/21/2023

ABRACON IS  
 ISO9001-2015  
 CERTIFIED

## X-ON Electronics

Largest Supplier of Electrical and Electronic Components

*Click to view similar products for [RF inductors - SMD category](#):*

*Click to view products by [Abracon manufacturer](#):*

Other Similar products are found below :

[MHL1ECTTP82NJ](#) [MHL1ECTTP8N2J](#) [CIH10T12NJNC](#) [B82498B1332J000](#) [B82498B3121J000](#) [0805WL220GT](#) [1008WL101GT](#)  
[0805WL681GT](#) [IWC0402D27NR-3G](#) [IWC0603F68NR-3G](#) [IWC0402AR10R-3G](#) [0603WL470JT](#) [IWC0402D33NR-3G](#) [IWC0603F47NR-3G](#)  
[0805WL151JT](#) [IWC0402A68NR-3G](#) [IWC0402AR12R-3G](#) [IWC0402A82NR-3G](#) [IWC0402B39NR-3G](#) [IWC0603CR12R-3G](#)  
[IWC0603AR33R-3G](#) [IWC0603BR18R-3G](#) [IWC0603F39NR-3G](#) [IWC0603BR22R-3G](#) [IWC0402A47NR-3G](#) [IWC0603AR27R-3G](#)  
[IWC0603F27NR-3G](#) [IWC1008DR68R-3G](#) [IWC1008FR12R-3G](#) [IWC1008FR18R-3G](#) [IWC1008J33NR-3G](#) [IWC1008J82NR-3G](#)  
[IWC1008DR47R-3G](#) [IWC1008J18NR-3G](#) [IWC0805E22NR-3G](#) [IWC1008DR82R-3G](#) [IWC0805E33NR-3G](#) [IWC1008J68NR-3G](#)  
[IWC0805D82NR-3G](#) [IWC0805DR10R-3G](#) [IWC0805E39NR-3G](#) [IWC1008DR39R-3G](#) [IWC0805DR15R-3G](#) [IWC1008J39NR-3G](#)  
[IWC1008J27NR-3G](#) [IWC0805DR18R-3G](#) [IWC0805E68NR-3G](#) [IWC1008ER27R-3G](#) [IWC1008FR10R-3G](#) [IWC1008J22NR-3G](#)