

# Ultra-Low Jitter, Fixed-Frequency SMD Clock Oscillator

AK2A

Request Samples



Check Inventory



ESD Sensitive



2.5 x 2.0 x 1.0 mm  
RoHS/RoHS II Compliant  
MSL Level = N/A

## Features

- Exceptionally Low RMS Jitter: 83fs Typ (LVDS @ 156.25MHz)
- Available in industry standard frequencies between 100MHz & 200MHz
- $\pm 25$ ppm stability over industrial operating temperature (-40°C to +85°C)
- 2.5V, 3.3V, 2.25V to 3.63V Continuous supply voltage options
- LVPECL, LVDS, HCSL differential output logic
- Industry standard 2.5 x 2.0 x 1.0 mm footprint
- Based on 3rd overtone, quartz crystal technology
- Available in Abracon's global distribution network
- Output Enable (Pad 1 or Pad 2 Active High) options available

## Applications

- Optical Transceivers and Modules
- Data Centers, Storage, and Servers
- Networking switches and gateways
- 100G/200G/400G/800G Ethernet
- Fibre Channel/SONET/SDH/PCIE
- Industrial and FPGA applications
- Test & measurement

## Key Electrical Specifications

Parameters	Min.	Typ.	Max.	Unit	Notes
Frequency Range	100		200	MHz	
Standard Available Frequencies	100.000, 114.285, 122.880, 125.000, 148.500, 150.000, 155.520, 156.250 & 200.000			MHz	Contact Abracon for availability of frequencies not listed
Supply Voltage (Vdd) <sup>[Note 1]</sup>	2.97	3.3	3.63	V	Option "A"
	2.375	2.5	2.625		Option "B"
	2.375		3.63		Option "D"
Supply Current (Idd)	LVPECL	40	60	mA	@ 200MHz; @ Vdd=3.3V
	LVDS	17	35		@ 200MHz; @ Vdd=3.3V
	HCSL	27	40		@ 200MHz; @ Vdd=3.3V
Operating Temperature Range	-20		70	°C	Option "D"
	-40		85		Option "F" or "Q"
Storage Temperature	-55		125	°C	
Frequency Tolerance <sup>[Note 2]</sup>	-10	< $\pm 5$	10	ppm	
Frequency Stability over Operating Temperature Range <sup>[Note 3,4]</sup>	-15	< $\pm 10$	15	ppm	Option "D" (-20°C to +70°C)
	-20	< $\pm 15$	20		Option "Q" (-40°C to +85°C)
	-25	< $\pm 20$	25		Option "F" (-40°C to +85°C)
First Year Aging	-3		3	ppm	At 25°C
All-Inclusive Frequency Accuracy (Total Stability) <sup>[Notes 5]</sup>	-40		40	ppm	Option "D" (-20°C to +70°C)
	-45		45		Option "Q" (-40°C to +85°C)
	-50		50		Option "F" (-40°C to +85°C)
Rise (Tr) / Fall (Tf) Time <sup>[Notes 6]</sup>	LVPECL		0.2	ns	@ Vdd=3.3V, RL=50Ω
			0.2		@ Vdd=3.3V, RL=100Ω
	LVDS		0.2		@ Vdd=2.5V, RL=100Ω
			0.5		@ Vdd=3.3V, RL=50Ω to GND
	HCSL		0.5		@ Vdd=2.5V, RL=50Ω to GND
Duty Cycle	45		55	%	
Start-up Time <sup>[Note 3]</sup>		< 2	5	ms	

Note 1: Supply voltage (Vdd) = 2.5V and 2.375~3.63V options not available with LVPECL output

Note 2: Frequency Accuracy (Initial Set-Tolerance), at time of shipment (pre-reflow), relative to carrier frequency, @ +25°C

Note 3: Relative to initial measured frequency @ +25°C

Note 4: Option Q only available in select frequencies. Please contact Abracon for availability

Note 5: Includes post reflow frequency accuracy, temperature stability, load pulling, power supply variation, and 10-year aging

Note 6: Measured over 20% to 80% of waveform



5101 Hidden Creek Ln Spicewood TX 78669  
Phone: 512-371-6159 | Fax: 512-351-8858  
For terms and conditions of sales, please visit:  
www.abracon.com

REVISED: 09-27-22

ABRACON IS  
ISO9001-2015  
CERTIFIED

# Ultra-Low Jitter, Fixed-Frequency SMD Clock Oscillator

AK2A

Request Samples



Check Inventory



ESD Sensitive



2.5 x 2.0 x 1.0 mm  
RoHS/RoHS II Compliant  
MSL Level = N/A

Parameters		Min.	Typ.	Max.	Unit	Notes	
Differential Output High Voltage (VOH) Output Low Voltage (VOL)	LVPECL	VOH	V <sub>dd</sub> -1.025	V <sub>dd</sub> -0.95	V <sub>dd</sub> -0.88	V	R <sub>L</sub> =50Ω to V <sub>dd</sub> -2.0V
		VOL	V <sub>dd</sub> -1.81	V <sub>dd</sub> -1.7	V <sub>dd</sub> -1.62		
	LVDS	VOH		1.43	1.60		R <sub>L</sub> =100Ω between both outputs
		VOL	0.90	1.10			
	HCSL	VOH	0.50	0.74	0.85		R <sub>L</sub> =50Ω to ground on each output
		VOL	-0.15	0.00	0.15		
Output Voltage Swing (Vopp)		0.400			V	LVPECL	
		0.250	0.350	0.450		LVDS	
		0.500	0.700	0.850		HCSL	
Output Enable & Disable Control		0.7*(V <sub>dd</sub> )			V	Output Enable or No Connect	
				0.3*(V <sub>dd</sub> )		Output Disable (High Impedance)	
Output Enable Time			< 1	5.0	ms		
Output Disable Time				0.2	μs		
Output Disable Current Consumption				10	μA	OE ≤ 0.3V	
RMS Phase Jitter (12kHz to 20MHz from Carrier)		See Table 1 below				V <sub>dd</sub> , output logic type and Carrier frequency dependent	

**Table 1**  
RMS Phase Jitter 12kHz – 20MHz BW, V<sub>dd</sub>=3.3V [Note 7, 8, 9]

Frequency (MHz)	Output	RMS Jitter	
		Typ. (fs)	Max (fs)
100	LVDS	184	200
	LVPECL	166	200
	HCSL	152	175
125	LVDS	118	150
	LVPECL	94	125
	HCSL	90	115
156.25	LVDS	83	125
	LVPECL	64	100
	HCSL	71	100
200	LVDS	55	100
	LVPECL	75	100
	HCSL	70	100

Note 7: Guaranteed by characterization; RMS Phase Jitter specifications are inclusive of any spurs

Note 8: Phase jitter measured with Keysight E5052B Signal Source Analyzer

Note 9: Refer to the next section for phase noise test setup and representative phase noise plots



5101 Hidden Creek Ln Spicewood TX 78669  
Phone: 512-371-6159 | Fax: 512-351-8858  
For terms and conditions of sales, please visit:  
www.abracon.com

REVISED: 09-27-22

ABRACON IS  
ISO9001-2015  
CERTIFIED

# Ultra-Low Jitter, Fixed-Frequency SMD Clock Oscillator

AK2A

Request Samples



Check Inventory



ESD Sensitive



2.5 x 2.0 x 1.0 mm  
RoHS/RoHS II Compliant  
MSL Level = N/A

## Absolute Maximum Ratings <sup>[Note 10]</sup>

Parameters	Min.	Typ.	Max.	Unit	Notes
Supply Voltage	V <sub>SS</sub> -0.5		5	V	
Input Voltage	V <sub>DD</sub> -0.5		V <sub>DD</sub> +0.5	V	
Output Voltage	V <sub>DD</sub> -0.5		V <sub>DD</sub> +0.5	V	
Maximum Junction Operating Temperature			150	°C	
Ambient Operating Temperature Range	-40		85	°C	Industrial
Ambient Operating Temperature Range	-20		70	°C	Extended Commercial
Reflow Temperature			260	°C	See Reflow Profile
ESD Protection	4kV HBM, 300V MM, 2kV CDM				

Note 10: Stresses above those listed under “Absolute Maximum Ratings” may cause permanent damage to the device. This is a stress rating only and functional operation of the device at those or any other conditions above those indicated in the operational sections of this specification is not intended. Exposure to maximum rating conditions for extended periods may affect device reliability. The data sheet limits are not guaranteed if the device is operated beyond the recommended operating conditions.

# Ultra-Low Jitter, Fixed-Frequency SMD Clock Oscillator

AK2A

Request Samples



Check Inventory



ESD Sensitive



2.5 x 2.0 x 1.0 mm  
RoHS/RoHS II Compliant  
MSL Level = N/A

## Options and Part Identification [Note 11]

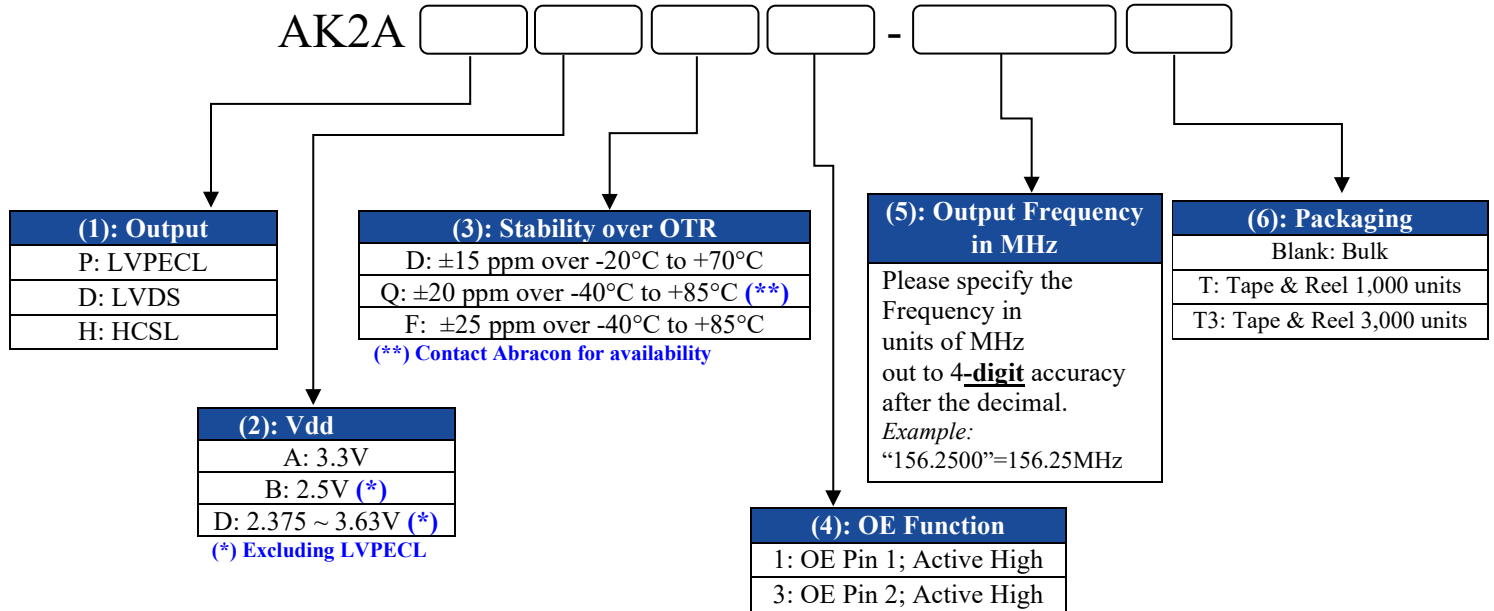

### Part Number Example:

AK2APAF1-156.2500  
AK2APAF1-156.2500T  
AK2APAF1-156.2500T3

Note 11: Contact Abracon for non-standard part number configurations and/or requests with carrier frequency callouts up to 5 & 6 digit accuracy after the decimal

# Ultra-Low Jitter, Fixed-Frequency SMD Clock Oscillator

AK2A

Request Samples



Check Inventory



ESD Sensitive



2.5 x 2.0 x 1.0 mm  
RoHS/RoHS II Compliant  
MSL Level = N/A

## Typical Frequency vs. Temperature Characteristics

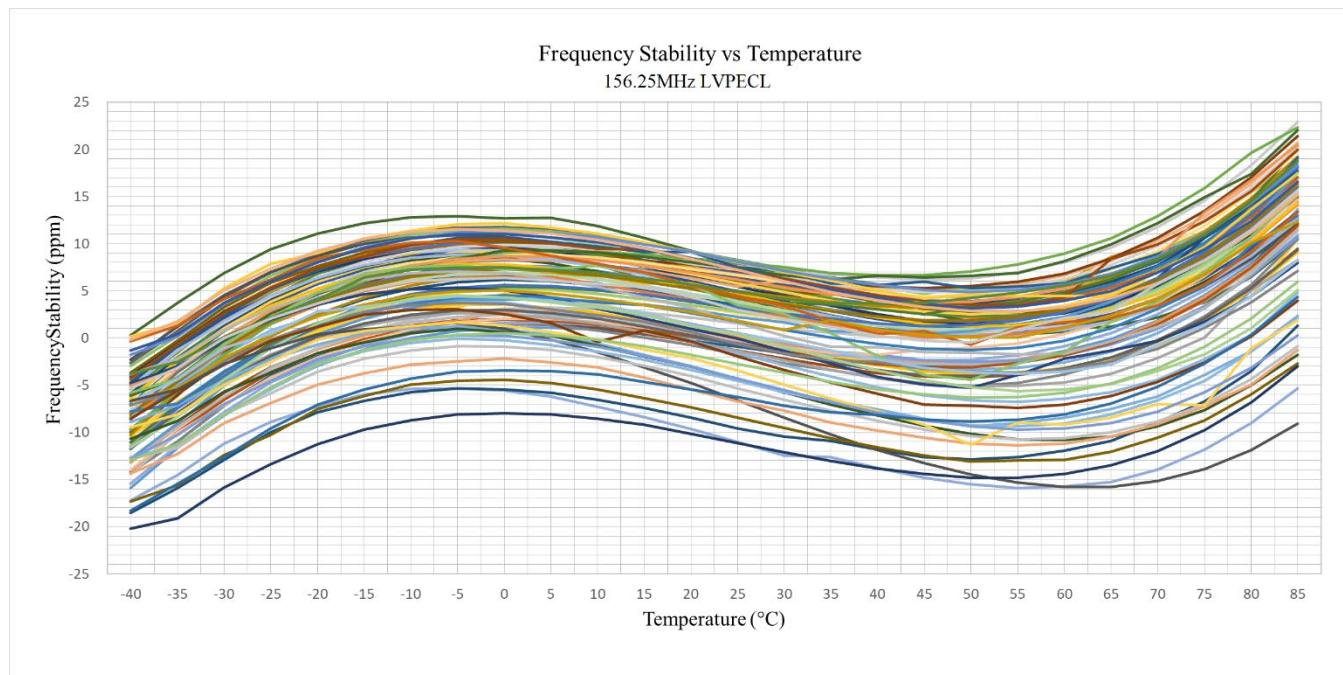
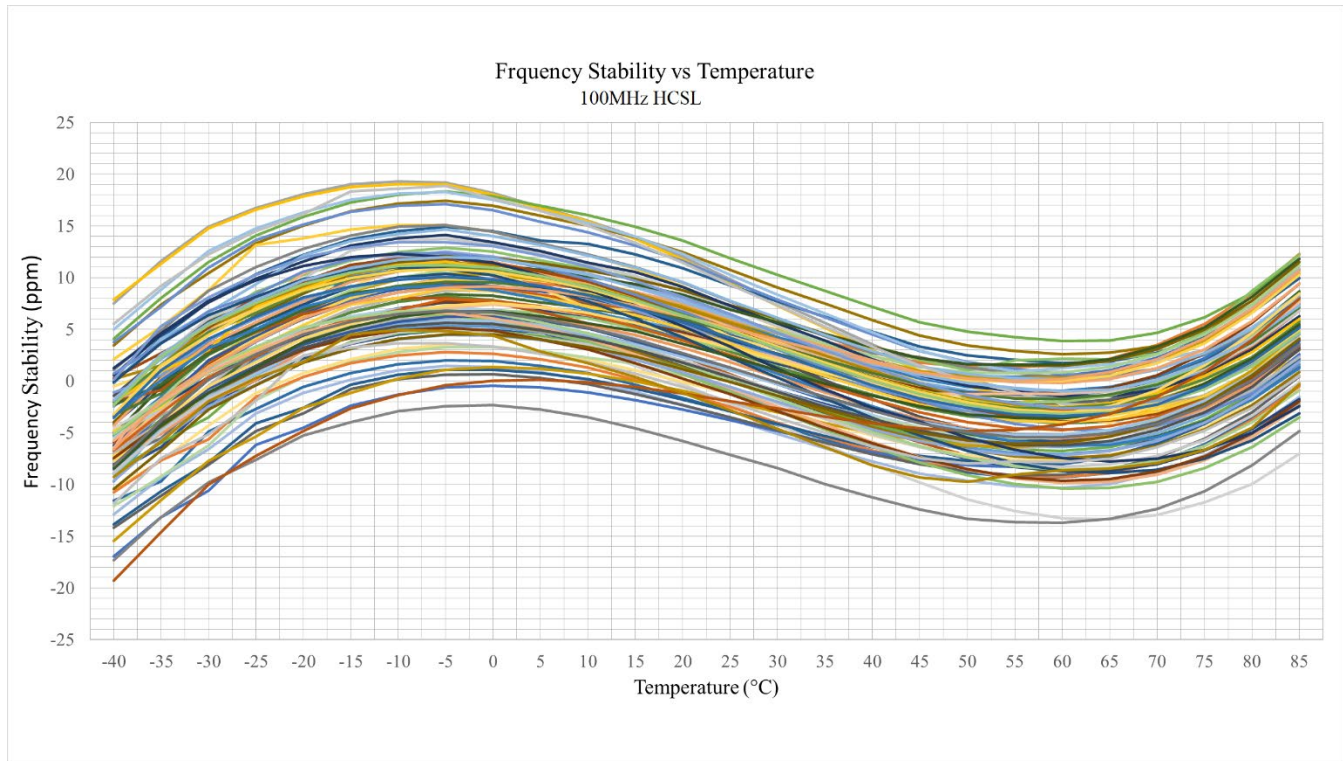

# Ultra-Low Jitter, Fixed-Frequency SMD Clock Oscillator

AK2A

Request Samples



Check Inventory



ESD Sensitive



2.5 x 2.0 x 1.0 mm  
RoHS/RoHS II Compliant  
MSL Level = N/A

## Differential Output Waveform

LVPECL: Output Wave Form (Duty, Tr, Tf)

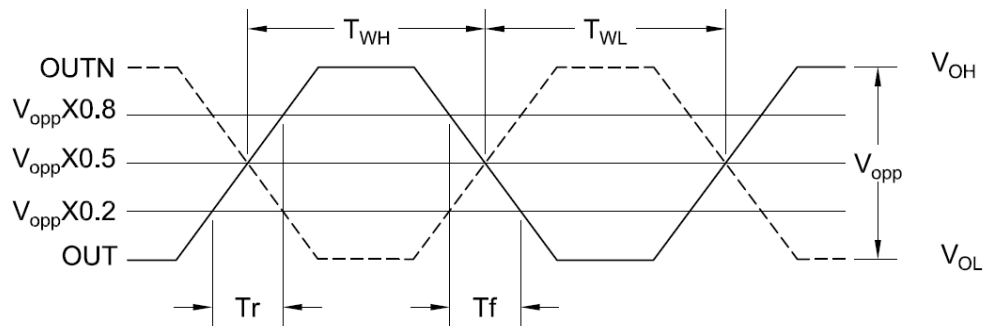

$$\text{Duty Cycle} = \frac{T_{WH}}{T_{WH} + T_{WL}} \times 100\%$$

LVDS: Output Wave Form (Duty, Tr, Tf, VOH, VOL, VOpp)

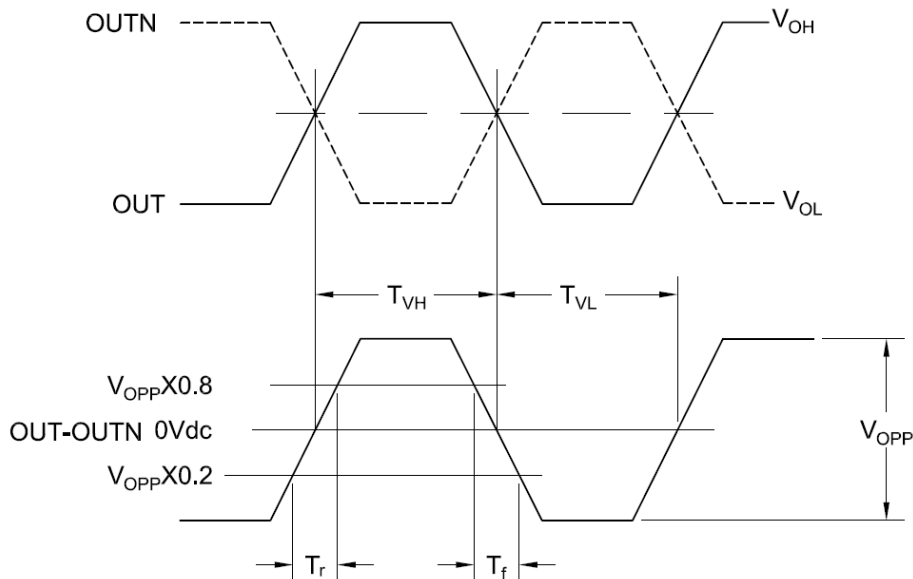

$$\text{Duty} = \frac{T_{VH}}{T_{VH} + T_{VL}} \times 100\%$$

# Ultra-Low Jitter, Fixed-Frequency SMD Clock Oscillator

AK2A

Request Samples



Check Inventory



ESD Sensitive



2.5 x 2.0 x 1.0 mm  
RoHS/RoHS II Compliant  
MSL Level = N/A

HCSL: Output Wave Form (Duty, Tr, Tf, VOH, VOL, VOpp )

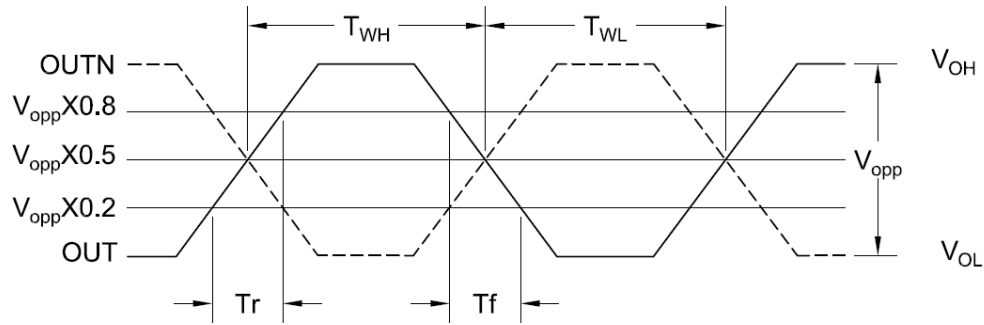

$$\text{Duty Cycle} = \frac{T_{WH}}{T_{WH} + T_{WL}} \times 100\%$$

# Ultra-Low Jitter, Fixed-Frequency SMD Clock Oscillator

AK2A

Request Samples



Check Inventory



ESD Sensitive



2.5 x 2.0 x 1.0 mm  
RoHS/RoHS II Compliant  
MSL Level = N/A

## Recommended Test Circuit [\[Note 12\]](#)

### LVPECL

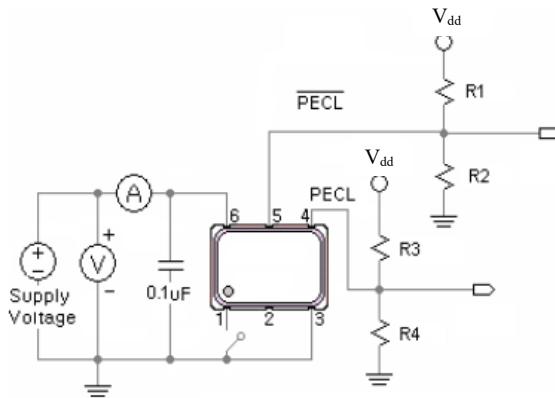

V<sub>dd</sub> = 3.3V; R<sub>1</sub>=R<sub>3</sub>=127Ω; R<sub>2</sub>=R<sub>4</sub>=82.5Ω

### LVDS

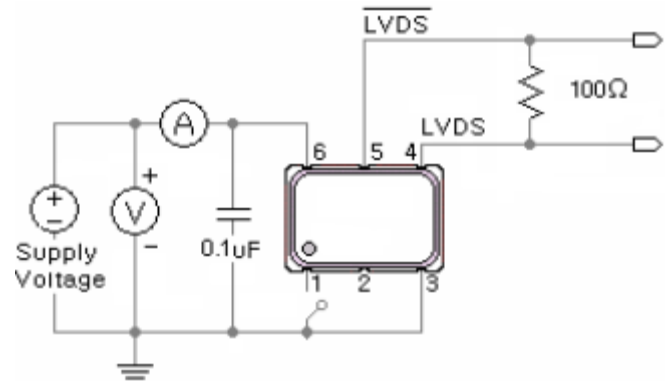

### HCSL

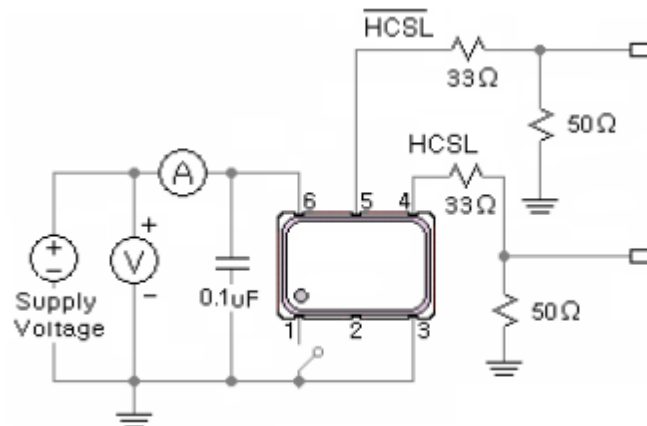

Note 12: Recommended test circuit images are representative of when the OE Function is located on Pin 1; when the OE Function is located on Pin 2, then Pin 1=No Connect & Pin 2=OE or No Connect.



# Ultra-Low Jitter, Fixed-Frequency SMD Clock Oscillator

AK2A

Request Samples



Check Inventory



ESD Sensitive



2.5 x 2.0 x 1.0 mm  
RoHS/RoHS II Compliant  
MSL Level = N/A

## Mechanical Dimensions

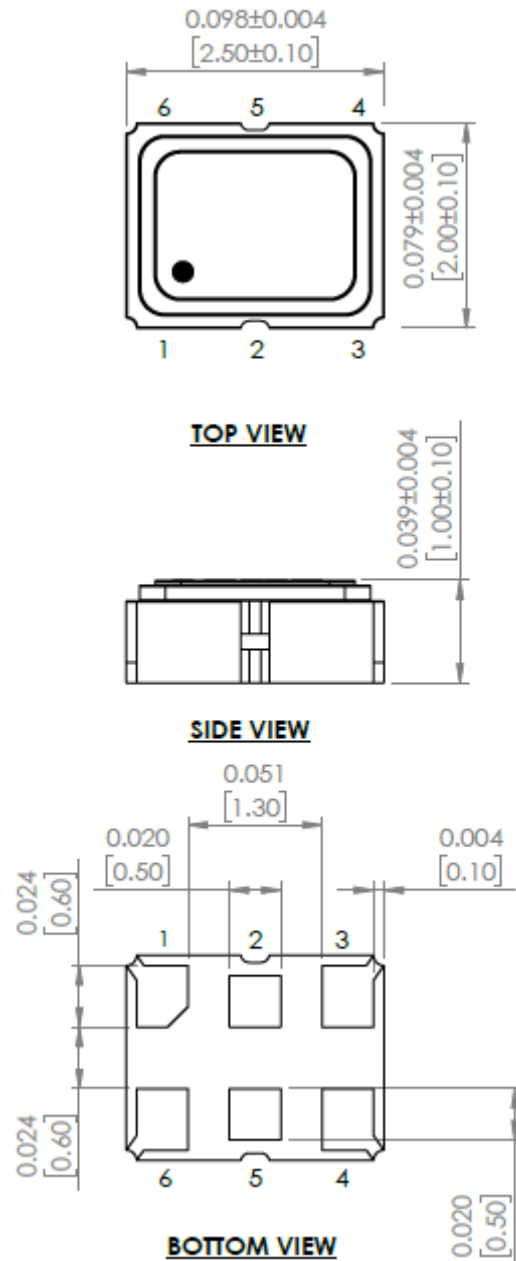

## Recommended Land Pattern

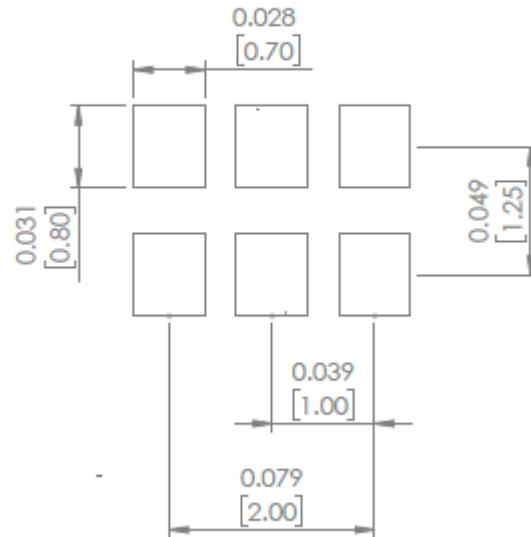

Case 1 Pin #1=Output Enable/Disable Function where OE is Active HIGH		Case 2 Pin #2=Output Enable/Disable Function where OE is Active HIGH	
Pin	Description	Pin	Description
# 1	Output Enable = Logic High, "1", Vdd	# 2	Output Enable = Logic High, "1", Vdd
	Output Disable = Logic Low, "0", GND		Output Enable = Logic Low, "0", GND
# 2	No Connect	# 3	GND
# 3	GND	# 4	Output
# 4	Output	# 5	Complementary output
# 5	Complementary output	# 6	Supply Voltage (Vdd)
# 6	Supply Voltage (Vdd)		

Dimensions: inches [mm]



5101 Hidden Creek Ln Spicewood TX 78669  
Phone: 512-371-6159 | Fax: 512-351-8858  
For terms and conditions of sales, please visit:  
www.abracon.com

REVISED: 09-27-22

ABRACON IS  
ISO9001-2015  
CERTIFIED

# Ultra-Low Jitter, Fixed-Frequency SMD Clock Oscillator

AK2A

Request Samples



Check Inventory



ESD Sensitive



2.5 x 2.0 x 1.0 mm  
RoHS/RoHS II Compliant  
MSL Level = N/A

## Reflow Profile [JEDEC J-STD-020]

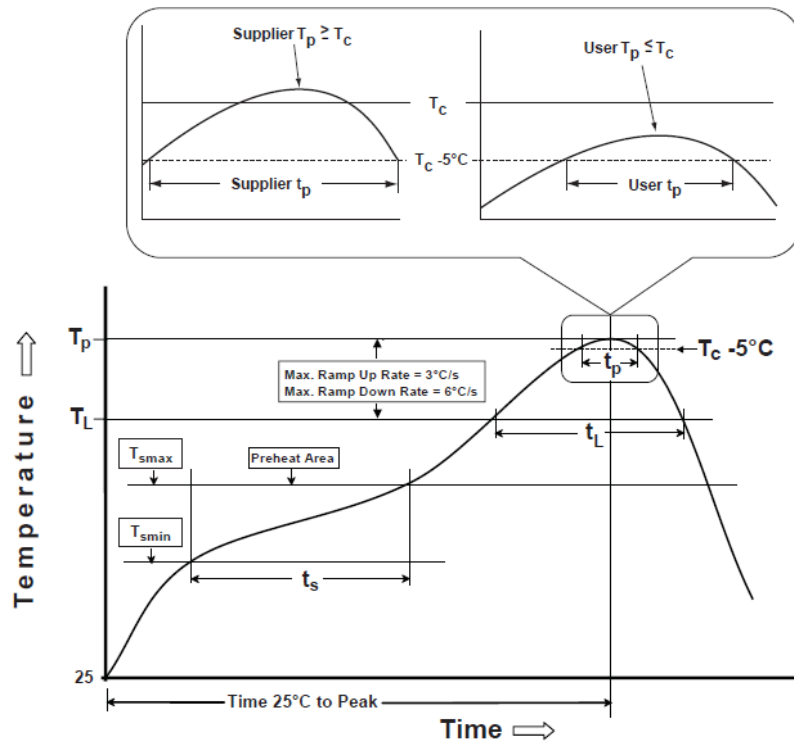

Table 1

SnPb Eutectic Process Classification Temperatures ( $T_c$ )		
Package Thickness	Volume mm <sup>3</sup> <350	Volume mm <sup>3</sup> ≥350
<2.5 mm	235 °C	220 °C
≥2.5 mm	220 °C	220 °C

Table 2

Pb-Free Process Classification Temperatures ( $T_c$ )			
Package Thickness	Volume mm <sup>3</sup> <350	Volume mm <sup>3</sup> 350-2000	Volume mm <sup>3</sup> >2000
<1.6 mm	260 °C	260 °C	260 °C
1.6 mm - 2.5 mm	260 °C	250 °C	245 °C
>2.5 mm	250 °C	245 °C	245 °C

Profile Feature	Sn-Pb Eutectic Assembly	Pb-Free Assembly
Preheat / soak		
Temperature minimum ( $T_{smin}$ )	100°C	150°C
Temperature maximum ( $T_{smax}$ )	150°C	200°C
Time ( $T_{smin}$ to $T_{smax}$ ) ( $t_s$ )	60 - 120 sec.	60 - 120 sec.
Average ramp-up rate ( $T_{smax}$ to $T_p$ )	3°C/sec. max	3°C/sec. max
Liquidous temperature ( $T_L$ )	183°C	217°C
Time at liquidous ( $t_L$ )	60 - 150 sec.	60 - 150 sec.
Peak package body temperature ( $T_p$ )*	see Table 1	see Table 2
Time ( $t_p$ )** within 5°C of the specified classification temperature ( $T_c$ )	20 sec.	30 sec.
Ramp-down rate ( $T_p$ to $T_{smax}$ )	6°C/sec. max	6°C/sec. max
Time 25°C to peak temperature	6 min. max	8 min. max
Reflow cycles	2 max	2 max

\*Tolerance for peak profile temperature ( $T_p$ ) is defined as a supplier minimum and a user maximum.

\*\*Tolerance for time at peak profile temperature ( $t_p$ ) is defined as supplier minimum and a user maximum.



5101 Hidden Creek Ln Spicewood TX 78669  
Phone: 512-371-6159 | Fax: 512-351-8858  
For terms and conditions of sales, please visit:  
www.abracon.com

REVISED: 09-27-22

ABRACON IS  
ISO9001-2015  
CERTIFIED

# Ultra-Low Jitter, Fixed-Frequency SMD Clock Oscillator

AK2A

Request Samples



Check Inventory



ESD Sensitive



2.5 x 2.0 x 1.0 mm  
RoHS/RoHS II Compliant  
MSL Level = N/A

## Packaging

Blank = Bulk

T = Tape & Reel 1,000 units/reel

T3 = Tape & Reel 3,000 units/reel

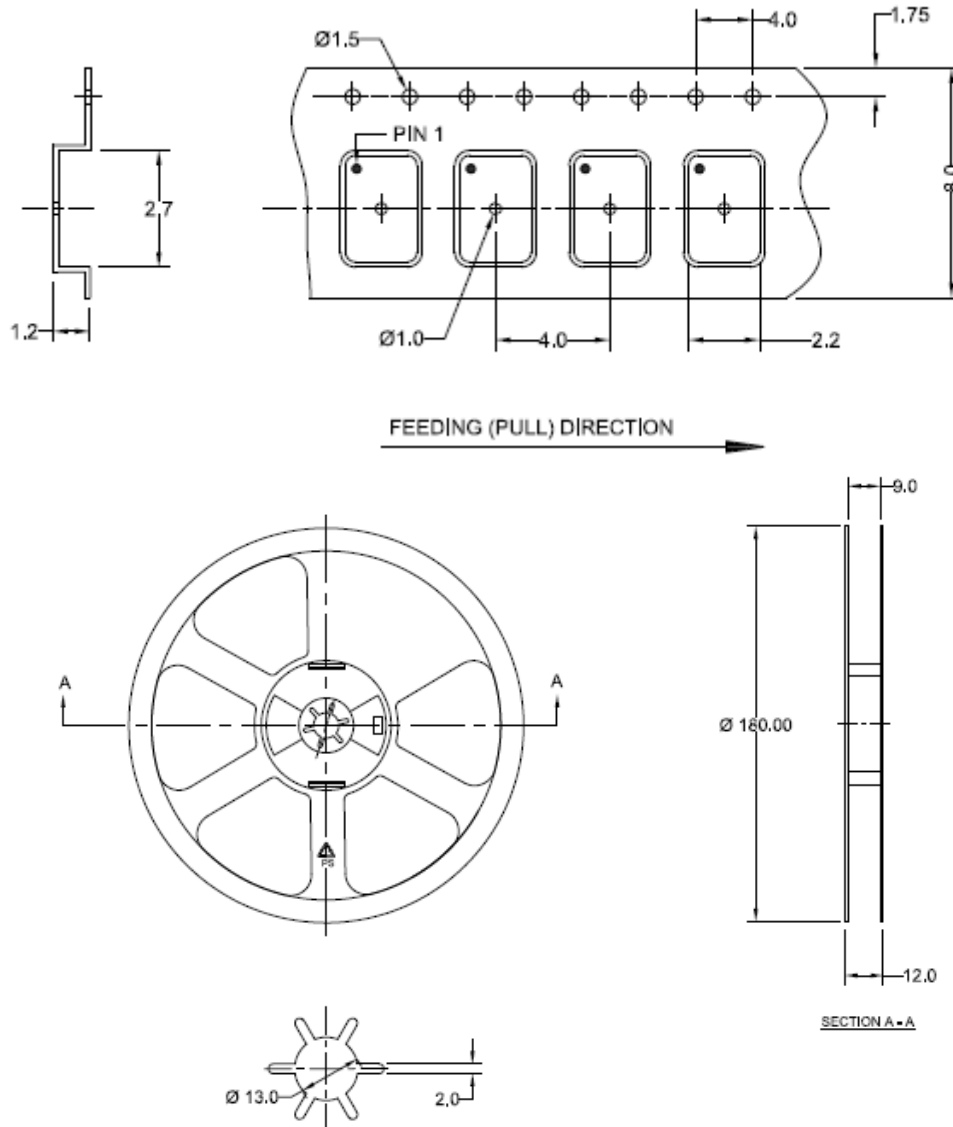

Dimensions: mm

**ATTENTION:** Abracon LLC's products are COTS – Commercial-Off-The-Shelf products; suitable for Commercial, Industrial and, where designated, Automotive Applications. Abracon's products are not specifically designed for Military, Aviation, Aerospace, Life-dependent Medical applications or any application requiring high reliability where component failure could result in loss of life and/or property. For applications requiring high reliability and/or presenting an extreme operating environment, written consent and authorization from Abracon LLC is required. Please contact Abracon LLC for more information.



5101 Hidden Creek Ln Spicewood TX 78669  
Phone: 512-371-6159 | Fax: 512-351-8858  
For terms and conditions of sales, please visit:  
[www.abracon.com](http://www.abracon.com)

REVISED: 09-27-22

ABRACON IS  
ISO9001-2015  
CERTIFIED

## X-ON Electronics

Largest Supplier of Electrical and Electronic Components

*Click to view similar products for [Standard Clock Oscillators](#) category:*

*Click to view products by [Abracon](#) manufacturer:*

Other Similar products are found below :

[601252](#) [F335-25](#) [F535L-33.333](#) [F535L-50](#) [NBXHBA019LN1TAG](#) [SiT1602BI-22-33E-50.000000E](#) [SIT8918AA-11-33S-50.000000G](#)  
[SM4420TEV-40.0M-T1K](#) [F335-24](#) [F335-40](#) [F535L-10](#) [F535L-12](#) [F535L-24](#) [F535L-27](#) [PE7744DW-100.0M](#) [ASF1-3.686MHZ-N-K-S](#) [ASV-](#)  
[4.000MHZ-LCS-T](#) [XLH735025.000JU4I8](#) [XLP725125.000JU6I8](#) [XO57CTECNA3M6864](#) [601251](#) [SiT8503AI-18-33E-0.200000X](#)  
[SIT8918AA-11-33S-16.000000G](#) [SIT9122AI2C233E300.000000X](#) [9120AC-2D2-33E212.500000](#) [9102AI-243N25E100.00000](#) [8208AC-82-](#)  
[18E-25.00000](#) [8008AI-72-XXE-24.545454E](#) [8004AC-13-33E-133.33000X](#) [AS-4.9152-16-SMD-TR](#) [ASFL1-48.000MHZ-LC-T](#)  
[632L3I004M00000](#) [SIT8920AM-31-33E-25.0000](#) [DSC1028DI2-019.2000](#) [9121AC-2C3-25E100.00000](#) [9102AI-233N33E100.00000X](#)  
[9102AI-233N25E200.00000](#) [9102AI-232H25S125.00000](#) [9102AI-133N25E200.00000](#) [9102AC-283N25E200.00000](#) [9001AC-33-33E1-30.000](#)  
[8103AC-13-33E-12.00000X](#) [3921AI-2CF-33NZ125.000000](#) [5730-1SF](#) [XUN736000.032768I](#) [ASV-25.000MHZ-ECS-50-T](#) [EC3925ETTTS-](#)  
[100.000M TR](#) [SIT1602BC-83-33E-10.000000Y](#) [8003AI-12-33S-40.00000Y](#) [1602BI-13-33S-19.200000E](#)