

ClearClock™ Oscillator Family | Low-Power HCSL | 3.2x2.5mm XO

AK3LP

Request Samples



Check Inventory



ESD Sensitive



3.2 x 2.5 x 1.0 mm

RoHS/RoHS II Compliant

MSL Level = N/A

Features

- Exceptionally Low RMS Jitter: 117fs Typ (@ 156.25MHz)
- Available in industry standard frequencies between 100MHz & 156.25MHz
- ± 25 ppm stability over industrial operating temperature (-40°C to +85°C)
- 1.8V, 2.5V, 3.3V, 1.71V to 3.63V Continuous supply voltage options
- Industry standard 3.2 x 2.5 x 1.0 mm footprint
- Based on 3rd overtone, quartz crystal technology
- Available in Abracon's global distribution network
- Output Enable (Pad 1 or Pad 2 Active High) options available

Applications

- Optical Transceivers and Modules
- Data Centers, Storage, and Servers
- Networking switches and gateways
- 100G/200G/400G/800G Ethernet
- Fibre Channel/SONET/SDH/PCIe
- Industrial and FPGA applications
- Test & measurement

Key Electrical Specifications

Parameters	Min.	Typ.	Max.	Unit	Notes
Frequency Range	100		156.25	MHz	
Standard Available Frequencies	100.000, 114.285, 122.880, 125.000, 148.500, 150.000, 155.520, 156.250			MHz	Contact Abracon for availability of frequencies not listed
Supply Voltage (Vdd)	2.97	3.3	3.63	V	Option "A"
	2.375	2.5	2.625		Option "B"
	1.71	1.8	1.89		Option "C"
	1.71		3.63		Option "E"
Supply Current (Idd)	HCSL	12	20	mA	@ 100MHz, Vdd=3.3V
		15	24		@ 156.25MHz, Vdd=3.3V
Operating Temperature Range	-20		70	°C	Option "D"
	-40		85		Option "F" or "Q"
Storage Temperature	-55		150	°C	
Frequency Tolerance ^[Note 1]	-10	< ± 5	10	ppm	
Frequency Stability over ^[Note 2,3] Operating Temperature Range	-15	< ± 10	15	ppm	Option "D" (-20°C to +70°C)
	-20	< ± 15	20		Option "Q" (-40°C to +85°C)
	-25	< ± 20	25		Option "F" (-40°C to +85°C)
First Year Aging	-3		3	ppm	At 25°C
All-Inclusive Frequency Accuracy (Total Stability) ^[Notes 4]	-40		40	ppm	Option "D" (-20°C to +70°C)
	-45		45		Option "Q" (-40°C to +85°C)
	-50		50		Option "F" (-40°C to +85°C)
Rise (Tr) / Fall (Tf) Time ^[Notes 5]		0.45	0.7	ns	RL=No Load
Duty Cycle	45		55	%	
Start-up Time ^[Note 2]		< 2	5	ms	

Note 1: Frequency Accuracy (Initial Set-Tolerance), at time of shipment (pre-reflow), relative to carrier frequency, @ +25°C

Note 2: Relative to initial measured frequency @ +25°C

Note 3: Option Q only available in select frequencies. Please contact Abracon for availability

Note 4: Includes post reflow frequency accuracy, temperature stability, load pulling, power supply variation, and 10-year aging

Note 5: Measured over 20% to 80% of waveform



5101 Hidden Creek Ln Spicewood TX 78669
 Phone: 512-371-6159 | Fax: 512-351-8858
 For terms and conditions of sales, please visit:
www.abracon.com

REVISED: 07-19-23

ABRACON IS
 ISO9001-2015
 CERTIFIED

ClearClock™ Oscillator Family | Low-Power HCSL | 3.2x2.5mm XO

AK3LP

Request Samples



Check Inventory



ESD Sensitive



3.2 x 2.5 x 1.0 mm

RoHS/RoHS II Compliant

MSL Level = N/A

Parameters		Min.	Typ.	Max.	Unit	Notes
Differential Output High Voltage (VOH) Output Low Voltage (VOL)	HCSL	V _{OH}	0.550		0.900	V R _L = No Load
		V _{OL}	-0.15	0.00	0.15	
Output Voltage Swing (V _{opp})		0.550			V	
Output Enable & Disable Control		0.7*(V _{dd})			V	Output Enable or No Connect
				0.3*(V _{dd})		Output Disable (High Impedance)
Output Enable Time			< 1	5.0	ms	
Output Disable Time				0.2	μs	
Output Disable Current Consumption				10	μA	OE ≤ 0.3V
RMS Phase Jitter (12kHz to 20MHz from Carrier)		See Table 1 below				V _{dd} , output logic type and Carrier frequency dependent

Table 1
RMS Phase Jitter 12kHz – 20MHz BW ^[Note 6, 7]

Frequency (MHz)	V _{dd} (V)	RMS Jitter	
		Typ. (fs)	Max (fs)
100	1.8	188	225
	2.5	188	225
	3.3	185	225
156.25	1.8	127	150
	2.5	111	150
	3.3	117	150

Note 6: Guaranteed by characterization; RMS Phase Jitter specifications are inclusive of any spurs

Note 7: Phase jitter measured with Keysight E5052B Signal Source Analyzer

ClearClock™ Oscillator Family | Low-Power HCSL | 3.2x2.5mm XO

AK3LP

Request Samples



Check Inventory



ESD Sensitive



3.2 x 2.5 x 1.0 mm
RoHS/RoHS II Compliant
MSL Level = N/A

Absolute Maximum Ratings ^[Note 8]

Parameters	Min.	Typ.	Max.	Unit	Notes
Supply Voltage	V _{SS} -0.5		5	V	
Input Voltage	V _{SS} -0.5		V _{DD} +0.5	V	
Output Voltage	V _{SS} -0.5		V _{DD} +0.5	V	
Maximum Junction Operating Temperature			150	°C	
Ambient Operating Temperature Range	-40		85	°C	Industrial
Ambient Operating Temperature Range	-20		70	°C	Extended Commercial
Reflow Temperature			260	°C	See Reflow Profile
ESD Protection	4kV HBM, 300V MM, 2kV CDM				

Note 8: Stresses above those listed under “Absolute Maximum Ratings” may cause permanent damage to the device. This is a stress rating only and functional operation of the device at those or any other conditions above those indicated in the operational sections of this specification is not intended. Exposure to maximum rating conditions for extended periods may affect device reliability. The data sheet limits are not guaranteed if the device is operated beyond the recommended operating conditions.

ClearClock™ Oscillator Family | Low-Power HCSL | 3.2x2.5mm XO

AK3LP

Request Samples



Check Inventory



ESD Sensitive



3.2 x 2.5 x 1.0 mm
RoHS/RoHS II Compliant
MSL Level = N/A

Options and Part Identification ^[Note 9]

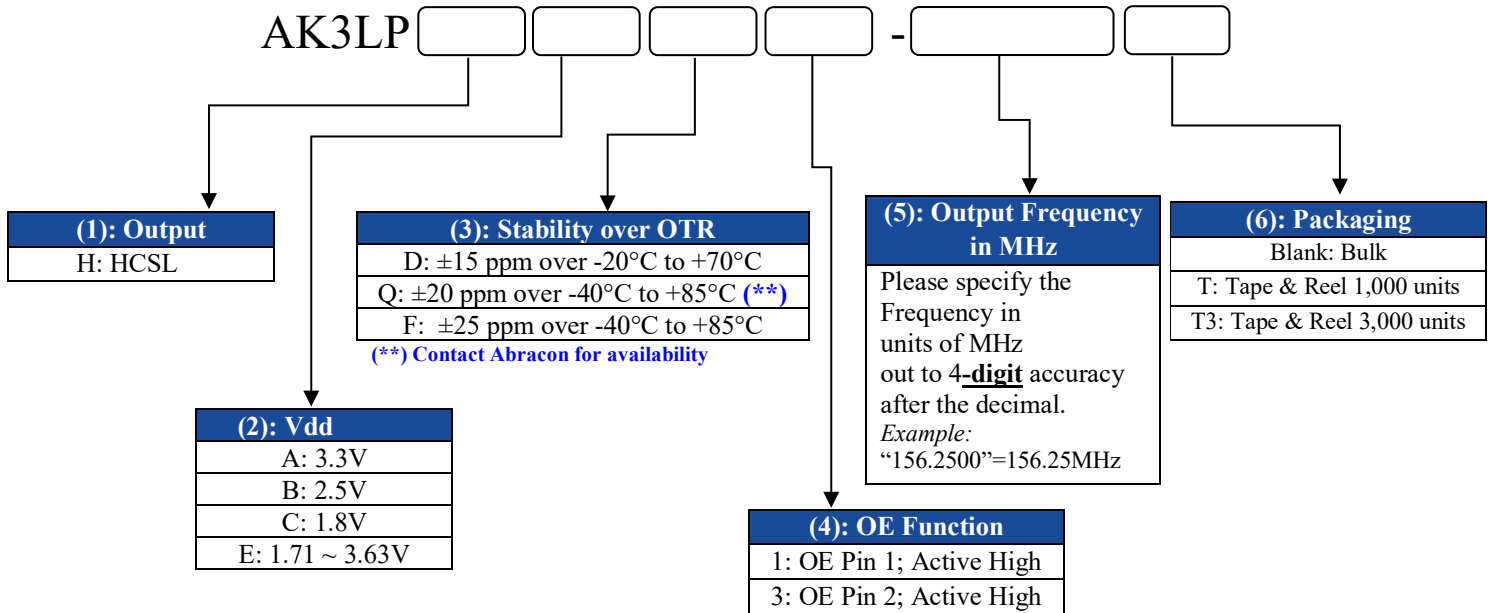

Part Number Example:

AK3LPHAF1-156.2500
AK3LPHAF1-156.2500T
AK3LPHAF1-156.2500T3

Note 9: Contact Abracon for non-standard part number configurations and/or requests with carrier frequency callouts up to 5 & 6 digit accuracy after the decimal

ClearClock™ Oscillator Family | Low-Power HCSL | 3.2x2.5mm XO

AK3LP

Request Samples



Check Inventory



ESD Sensitive



3.2 x 2.5 x 1.0 mm
RoHS/RoHS II Compliant
MSL Level = N/A

Typical Frequency vs. Temperature Characteristics

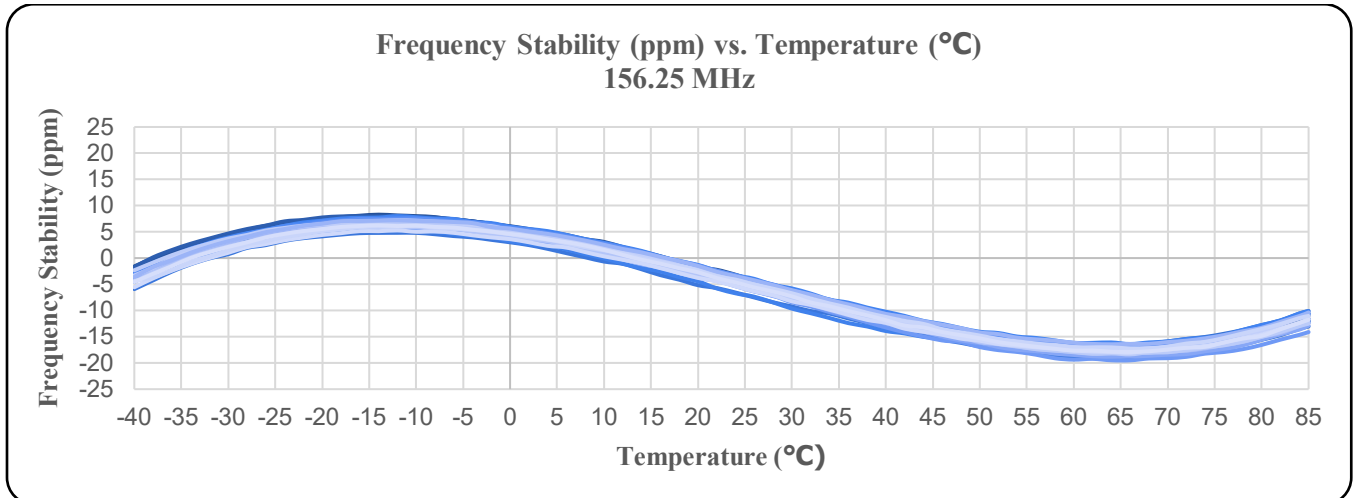
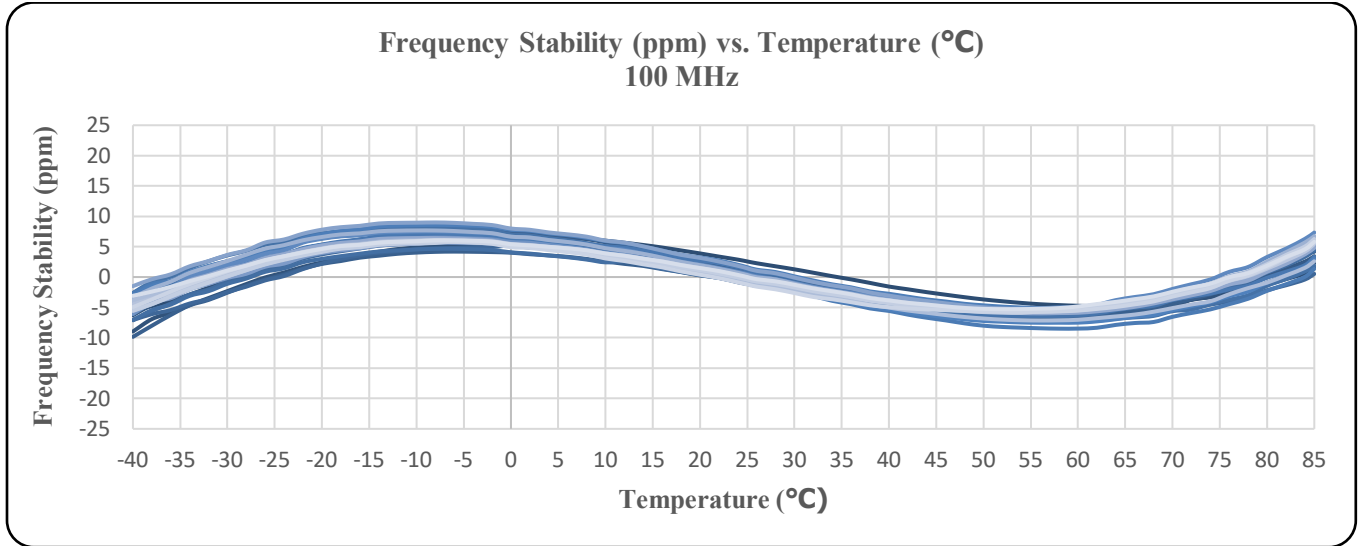

ClearClock™ Oscillator Family | Low-Power HCSL | 3.2x2.5mm XO

AK3LP

Request Samples



Check Inventory



ESD Sensitive



3.2 x 2.5 x 1.0 mm
RoHS/RoHS II Compliant
MSL Level = N/A

Differential Output Waveform

HCSL: Output Wave Form (Duty, Tr, Tf, VOH, VOL, Vopp)

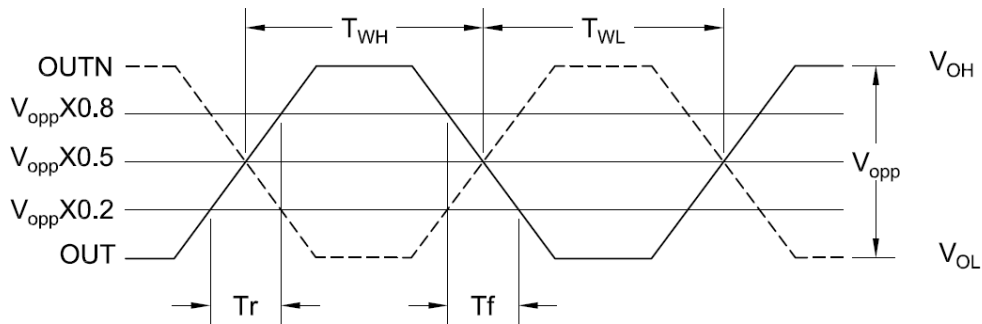

$$\text{Duty Cycle} = \frac{T_{WH}}{T_{WH} + T_{WL}} \times 100\%$$

Recommended Test Circuit ^[Note 10]

LP-HCSL

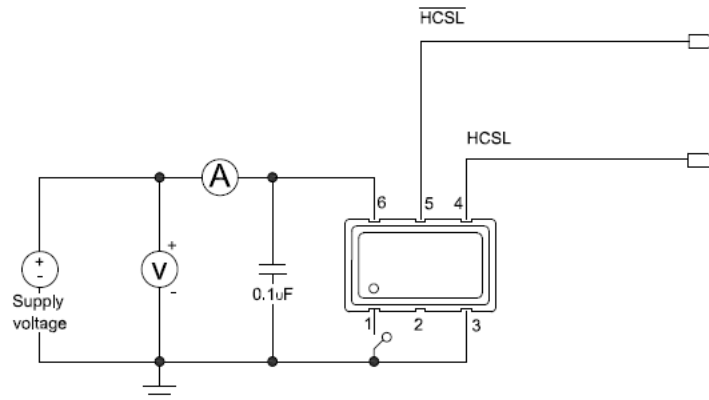

Note 10: Recommended test circuit images are representative of when the OE Function is located on Pin 1; when the OE Function is located on Pin 2, then Pin 1=No Connect & Pin 2=OE or No Connect.



5101 Hidden Creek Ln Spicewood TX 78669
Phone: 512-371-6159 | Fax: 512-351-8858
For terms and conditions of sales, please visit:
www.abracon.com

REVISED: 07-19-23

ABRACON IS
ISO9001-2015
CERTIFIED

ClearClock™ Oscillator Family | Low-Power HCSL | 3.2x2.5mm XO

AK3LP

Request Samples



Check Inventory



ESD Sensitive



3.2 x 2.5 x 1.0 mm
RoHS/RoHS II Compliant
MSL Level = N/A

Mechanical Dimensions

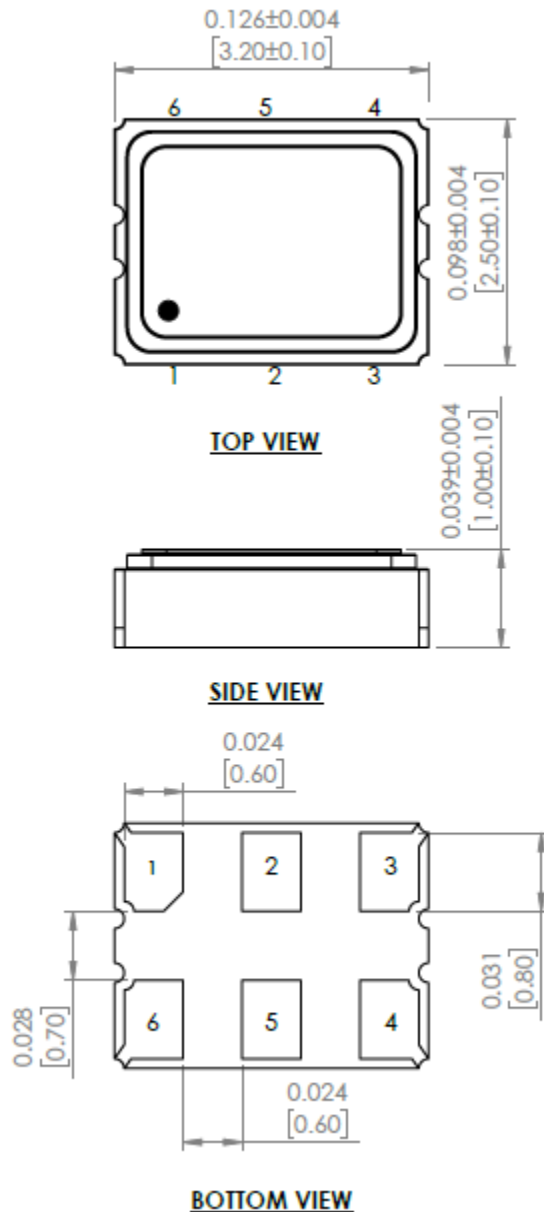

Recommended Land Pattern

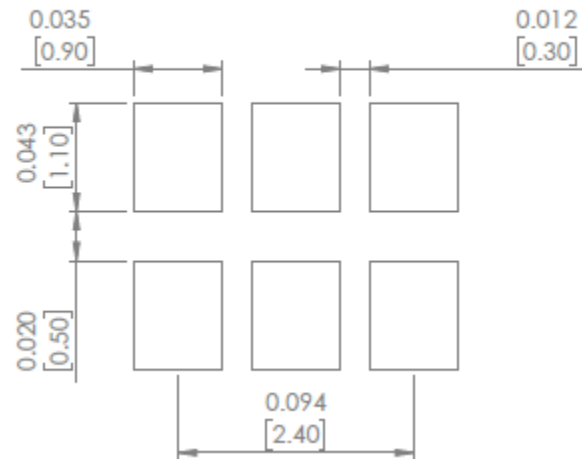

Case 1 Pin #1=Output Enable/Disable Function where OE is Active HIGH		Case 2 Pin #2=Output Enable/Disable Function where OE is Active HIGH	
Pin	Description	Pin	Description
# 1	Output Enable = Logic High, "1", Vdd	# 1	No Connect
	Output Disable = Logic Low, "0", GND	# 2	Output Enable = Logic High, "1", Vdd
# 2	No Connect		Output Enable = Logic Low, "0", GND
# 3	GND	# 3	GND
# 4	Output	# 4	Output
# 5	Complementary output	# 5	Complementary output
# 6	Supply Voltage (Vdd)	# 6	Supply Voltage (Vdd)

Dimensions: inches [mm]



5101 Hidden Creek Ln Spicewood TX 78669
Phone: 512-371-6159 | Fax: 512-351-8858
For terms and conditions of sales, please visit:
www.abracon.com

REVISED: 07-19-23

ABRACON IS
ISO9001-2015
CERTIFIED

ClearClock™ Oscillator Family | Low-Power HCSL | 3.2x2.5mm XO

AK3LP

Request Samples



Check Inventory



ESD Sensitive



3.2 x 2.5 x 1.0 mm
RoHS/RoHS II Compliant
MSL Level = N/A

Reflow Profile [JEDEC J-STD-020]

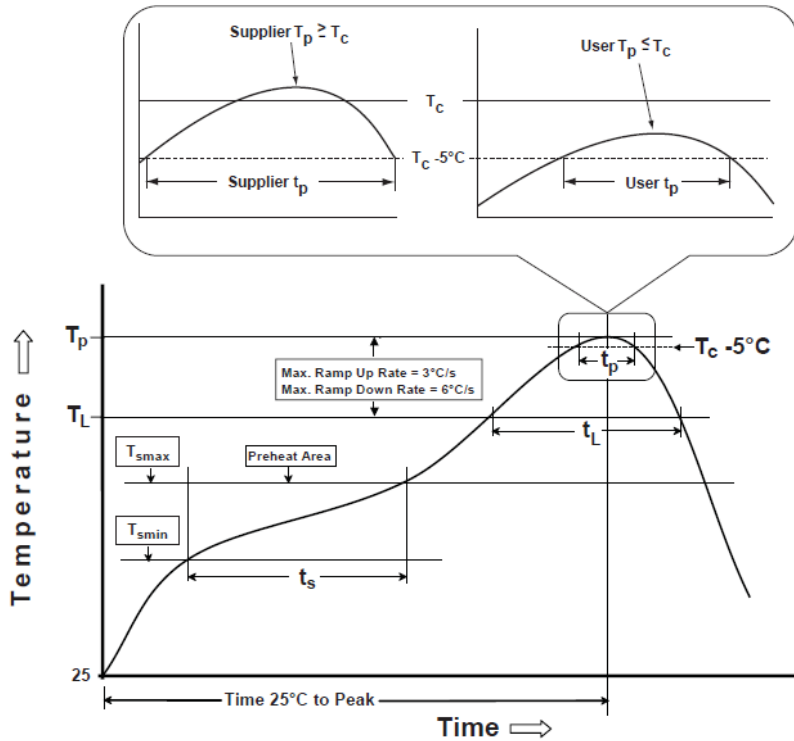

Table 1

SnPb Eutectic Process Classification Temperatures (T _c)		
Package Thickness	Volume mm ³ <350	Volume mm ³ ≥350
<2.5 mm	235 °C	220 °C
≥2.5 mm	220 °C	220 °C

Table 2

Pb-Free Process Classification Temperatures (T _c)			
Package Thickness	Volume mm ³ <350	Volume mm ³ 350-2000	Volume mm ³ >2000
<1.6 mm	260 °C	260 °C	260 °C
1.6 mm - 2.5 mm	260 °C	250 °C	245 °C
>2.5 mm	250 °C	245 °C	245 °C

Profile Feature	Sn-Pb Eutectic Assembly	Pb-Free Assembly
Preheat / soak		
Temperature minimum (T _{smmin})	100°C	150°C
Temperature maximum (T _{smmax})	150°C	200°C
Time (T _{smmin} to T _{smmax}) (t _s)	60 - 120 sec.	60 - 120 sec.
Average ramp-up rate (T _{smmax} to T _p)	3°C/sec. max	3°C/sec. max
Liquidous temperature (T _l)	183°C	217°C
Time at liquidous (t _l)	60 - 150 sec.	60 - 150 sec.
Peak package body temperature (T _p)*	see Table 1	see Table 2
Time (t _p)** within 5°C of the specified classification temperature (T _c)	20 sec.	30 sec.
Ramp-down rate (T _p to T _{smmax})	6°C/sec. max	6°C/sec. max
Time 25°C to peak temperature	6 min. max	8 min. max
Reflow cycles	2 max	2 max

*Tolerance for peak profile temperature (T_p) is defined as a supplier minimum and a user maximum.

**Tolerance for time at peak profile temperature (t_p) is defined as supplier minimum and a user maximum.



5101 Hidden Creek Ln Spicewood TX 78669
Phone: 512-371-6159 | Fax: 512-351-8858
For terms and conditions of sales, please visit:
www.abracon.com

REVISED: 07-19-23

ABRACON IS
ISO9001-2015
CERTIFIED

ClearClock™ Oscillator Family | Low-Power HCSL | 3.2x2.5mm XO

AK3LP

Request Samples



Check Inventory



ESD Sensitive



3.2 x 2.5 x 1.0 mm
RoHS/RoHS II Compliant
 MSL Level = N/A

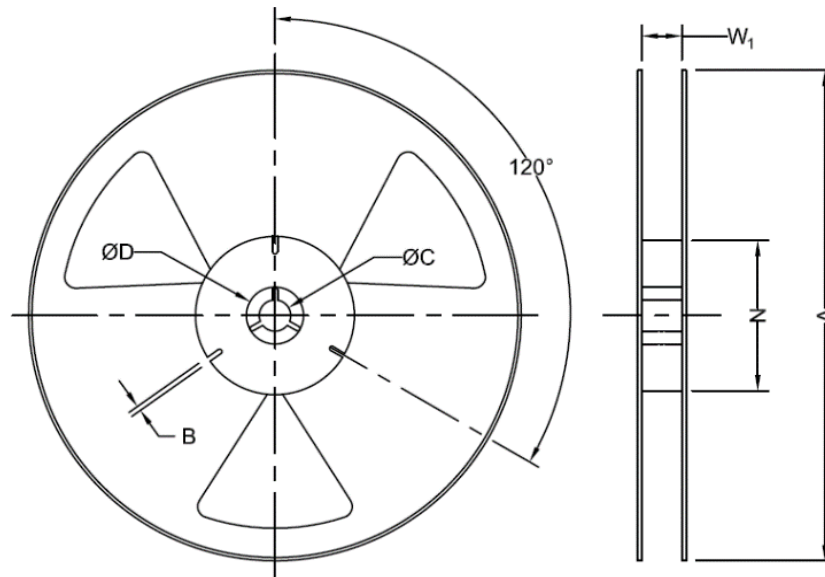

Unit: mm

Tape Specifications (mm)

Suffix	Qty/Reel	A (Nom)	B (Min)	C (Min)	D (Min)	N (Min)	*W ₁
-T	1000	178	1.5	13.0+0.5/-0.2	20.2	50	8.4+1.5/-0.0
-T3	3000	178	1.5	13.0+0.5/-0.2	20.2	50	8.4+1.5/-0.0

*Note: Measured at Hub

ATTENTION: Abracon LLC's products are COTS – Commercial-Off-The-Shelf products; suitable for Commercial, Industrial and, where designated, Automotive Applications. Abracon's products are not specifically designed for Military, Aviation, Aerospace, Life-dependent Medical applications or any application requiring high reliability where component failure could result in loss of life and/or property. For applications requiring high reliability and/or presenting an extreme operating environment, written consent and authorization from Abracon LLC is required. Please contact Abracon LLC for more information.



5101 Hidden Creek Ln Spicewood TX 78669
 Phone: 512-371-6159 | Fax: 512-351-8858
 For terms and conditions of sales, please visit:
www.abracon.com

REVISED: 07-19-23

ABRACON IS
 ISO9001-2015
 CERTIFIED

X-ON Electronics

Largest Supplier of Electrical and Electronic Components

Click to view similar products for [Standard Clock Oscillators](#) category:

Click to view products by [Abracon](#) manufacturer:

Other Similar products are found below :

[601252](#) [F335-25](#) [F535L-33.333](#) [F535L-50](#) [NBXHBA019LN1TAG](#) [SiT1602BI-22-33E-50.000000E](#) [SIT8918AA-11-33S-50.000000G](#)
[SM4420TEV-40.0M-T1K](#) [F335-24](#) [F335-40](#) [F535L-10](#) [F535L-12](#) [F535L-24](#) [F535L-27](#) [PE7744DW-100.0M](#) [ASF1-3.686MHZ-N-K-S](#) [ASV-](#)
[4.000MHZ-LCS-T](#) [XLH735025.000JU4I8](#) [XLP725125.000JU6I8](#) [XO57CTECNA3M6864](#) [601251](#) [SiT8503AI-18-33E-0.200000X](#)
[SIT8918AA-11-33S-16.000000G](#) [SIT9122AI2C233E300.000000X](#) [9120AC-2D2-33E212.500000](#) [9102AI-243N25E100.00000](#) [8208AC-82-](#)
[18E-25.00000](#) [8008AI-72-XXE-24.545454E](#) [8004AC-13-33E-133.33000X](#) [AS-4.9152-16-SMD-TR](#) [ASFL1-48.000MHZ-LC-T](#)
[632L3I004M00000](#) [SIT8920AM-31-33E-25.0000](#) [DSC1028DI2-019.2000](#) [9121AC-2C3-25E100.00000](#) [9102AI-233N33E100.00000X](#)
[9102AI-233N25E200.00000](#) [9102AI-232H25S125.00000](#) [9102AI-133N25E200.00000](#) [9102AC-283N25E200.00000](#) [9001AC-33-33E1-30.000](#)
[8103AC-13-33E-12.00000X](#) [3921AI-2CF-33NZ125.000000](#) [5730-1SF](#) [XUN736000.032768I](#) [ASV-25.000MHZ-ECS-50-T](#) [EC3925ETTTS-](#)
[100.000M TR](#) [SIT1602BC-83-33E-10.000000Y](#) [8003AI-12-33S-40.00000Y](#) [1602BI-13-33S-19.200000E](#)