

## Description

The AOC97 series is an Oven Controlled Crystal Oscillator (OCXO) offered in a 9.7mm x 7.5mm x 3.9mm four-pad SMD package. Tight frequency stability of  $\pm 10$ ppb over an extended operating temperature range of  $-40^{\circ}\text{C}$  to  $+95^{\circ}\text{C}$  is achieved using an SC-Cut, High “Q” resonator-based design. This series offers a CMOS-compatible output with a 3.3Vdc  $\pm 5\%$  supply voltage, common for most communication infrastructure, base station, and test and measurement equipment applications. The AOC97 series offers industry standard frequencies in the range of 10MHz to 48MHz with low long-term aging and excellent phase noise.

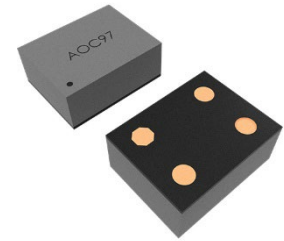

## Features

- SC-Cut, High “Q” resonator-based design
- 3.3Vdc supply voltage
- CMOS compatible output logic
- 9.7mm x 7.5mm x 3.9mm four pad SMD package
- Stability over temperature:  $\pm 10$ ppb over  $-40^{\circ}\text{C}$  to  $+95^{\circ}\text{C}$
- Low long-term aging:  $\pm 500$ ppb over first year
- Industry standard frequencies available
- Excellent phase noise

## Typical Applications

- Cellular infrastructure; Base stations
- Test & measurement equipment
- Switches & routers
- Time & frequency references
- Precision GPS
- Satellite Timing and Frequency
- High End Synthesizers
- Oil and Gas Exploration

## Electrical Specifications [Note 1]

Parameters	Min.	Typ.	Max.	Units	Notes
Frequency Range	10		48	MHz	
Standard Available Frequencies	10, 19.2, 20, 30.72, 38.88, 48			MHz	Contact Abracon for non-standard frequencies
Supply Voltage (Vdd)	3.135	3.3	3.456	V	
Input Power (warm-up)			2.1	W	
Input Power (steady-state)			0.8	W	
Operating Temperature Range	-40		+95	$^{\circ}\text{C}$	
Storage Temperature Range	-55		+105	$^{\circ}\text{C}$	
Initial Frequency Tolerance <small>[Note 2]</small>			$\pm 1$	ppm	
Frequency Stability over Operating Temperature Range <small>[Note 3]</small>			$\pm 10$	ppb	
Temperature Slope <small>[Note 4]</small>			$\pm 1$	ppb	
Stability vs. Supply Voltage			$\pm 5$	ppb	Vdd varied from 3.135V to 3.465V
Stability vs. Load			$\pm 5$	ppb	5% load change
Aging per Day			$\pm 3$	ppb	after 30 days of operation
Aging per Year			$\pm 500$	ppb	after 30 days of operation
Warm-up Time <small>[Note 5]</small>			3	minutes	
Start-up Time <small>[Note 6]</small>			50	ms	
<b>Output Waveform</b>					
High-level Output Voltage (V <sub>OH</sub> )	2.4			V	
Low-level Output Voltage (V <sub>OL</sub> )			0.4	V	
Output Signal		CMOS			
Output Load		15		pF	
Rise and Fall Time (t <sub>r</sub> , t <sub>f</sub> )			6	ns	10% to 90% of waveform
Duty Cycle	45		55	%	@50% of waveform

**Electrical Specifications *continued*** [Note 1]

Parameters	Min.	Typ.	Max.	Units	Notes
Phase Noise (@ 10.0000MHz)		-80	-70	dBc/Hz	1Hz offset
		-115	-110		10Hz offset
		-146	-138		100Hz offset
		-157	-151		1kHz offset
		-161	-156		10kHz offset
		-164	-159		100kHz offset
		-165	-161		1MHz offset
Phase Noise (@ 20.0000MHz)		-75	-65	dBc/Hz	1Hz offset
		-113	-108		10Hz offset
		-146	-138		100Hz offset
		-160	-154		1kHz offset
		-163	-158		10kHz offset
		-163	-158		100kHz offset
		-163	-158		1MHz offset
Phase Noise (@ 38.8800MHz)		-67	-57	dBc/Hz	1Hz offset
		-105	-97		10Hz offset
		-135	-125		100Hz offset
		-156	-151		1kHz offset
		-165	-160		10kHz offset
		-165	-160		100kHz offset
		-165	-160		1MHz offset
Phase Noise (@ 48.0000MHz)		-60	-50	dBc/Hz	1Hz offset
		-99	-90		10Hz offset
		-130	-120		100Hz offset
		-155	-150		1kHz offset
		-165	-160		10kHz offset
		-165	-160		100kHz offset
		-165	-160		1MHz offset

Note 1: All measurements guaranteed at +25°C, Vdd = 3.3V, CL =15pf unless otherwise specified.

Note 2: Measured at +25°C, Vdd=3.3V within 30 days, at time of shipment.

Note 3: Varied from -40 to +95°C, @ fref =(fmax +fmin )/2, Vdd=3.3V, CL=15pf, less than 2°C per minute

Note 4: Temperature slope ±1°C/min with any temperature window over -40 to +95°C

Note 5: Time until RF output is within ± 0.1 ppm referenced to last frequency reading 1 hour after startup TA=25°C.

Note 6: Time until RF output waveform is within output logic levels, duty cycle and rise/fall time specifications.

**Environmental and Mechanical**

Parameters	Description
MSL	3
REACH/RoHS II	Compliant
ESD	Sensitive

**Part Identification**

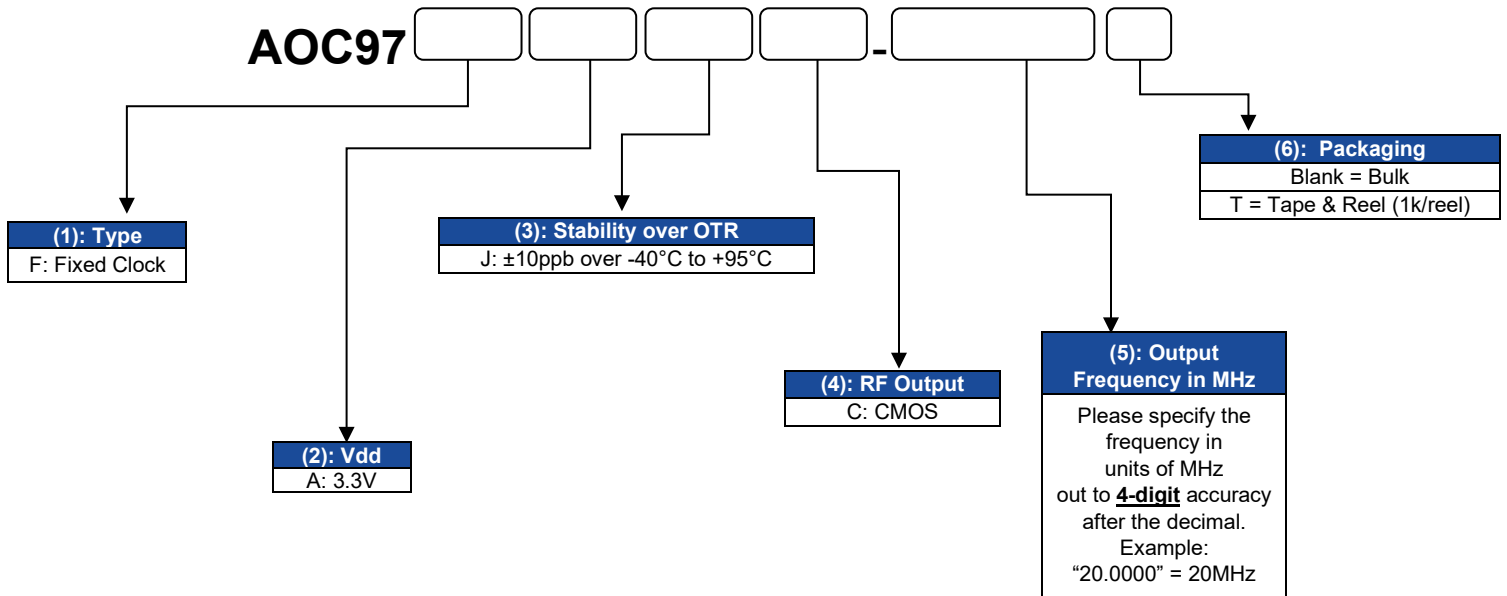

Part Number Example:

**AOC97FAJC-20.0000T**

**Mechanical Dimensions**

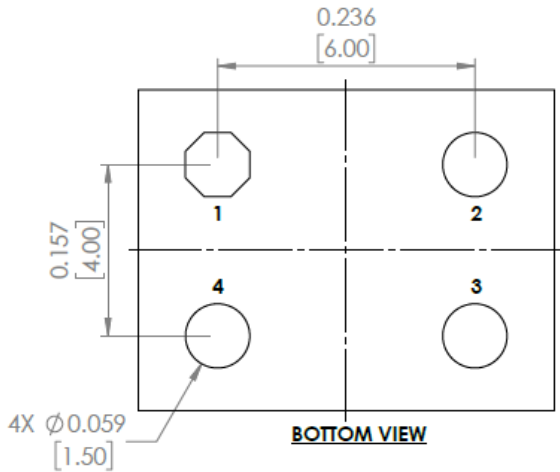
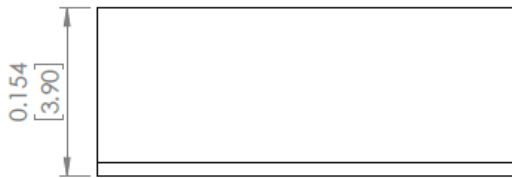
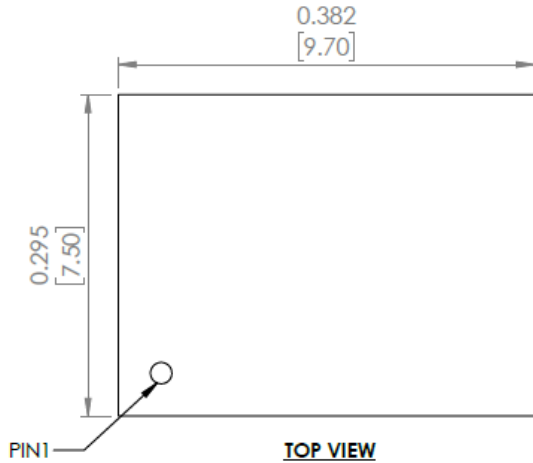

**RECOMMENDED LAND PATTERN**

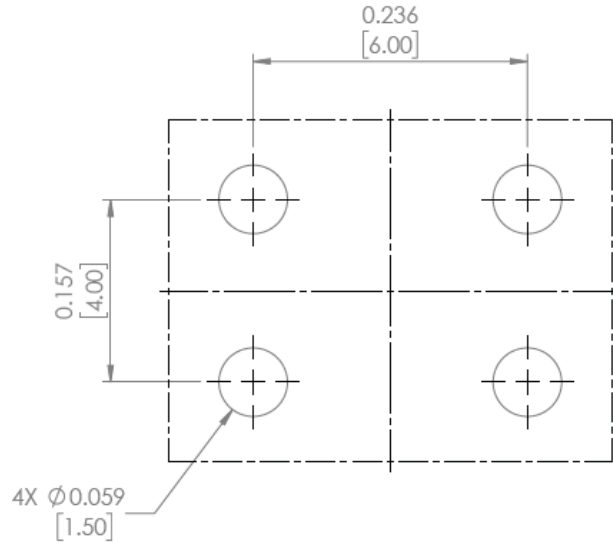

Pin #	Function
1	Do Not Connect
2	Ground
3	Output
4	Supply Voltage (Vdd)

**Dimensions: inches [mm]**

**Tolerance ±0.3mm without mark**

Reflow Profile [JEDEC J-STD-020]

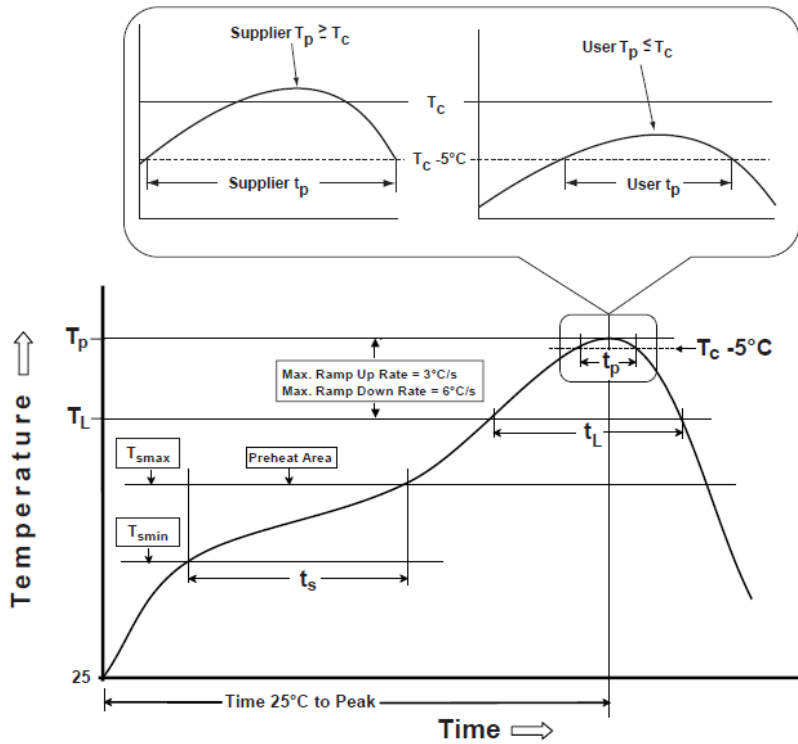

Table 1

SnPb Eutectic Process Classification Temperatures ( $T_c$ )		
Package Thickness	Volume $\text{mm}^3$ <350	Volume $\text{mm}^3$ $\geq$ 350
<2.5 mm	235 °C	220 °C
$\geq$ 2.5 mm	220 °C	220 °C

Table 2

Pb-Free Process Classification Temperatures ( $T_c$ )			
Package Thickness	Volume $\text{mm}^3$ <350	Volume $\text{mm}^3$ 350-2000	Volume $\text{mm}^3$ >2000
<1.6 mm	260 °C	260 °C	260 °C
1.6 mm - 2.5 mm	260 °C	250 °C	245 °C
>2.5 mm	250 °C	245 °C	245 °C

Profile Feature	Sn-Pb Eutectic Assembly	Pb-Free Assembly
Preheat / soak		
Temperature minimum ( $T_{smin}$ )	100°C	150°C
Temperature maximum ( $T_{smax}$ )	150°C	200°C
Time ( $T_{smin}$ to $T_{smax}$ ) ( $t_s$ )	60 - 120 sec.	60 - 120 sec.
Average ramp-up rate ( $T_{smax}$ to $T_p$ )	3°C/sec. max	3°C/sec. max
Liquidous temperature ( $T_L$ )	183°C	217°C
Time at liquidous ( $t_L$ )	60 - 150 sec.	60 - 150 sec.
Peak package body temperature ( $T_p$ )*	see Table 1	see Table 2
Time ( $t_p$ )** within 5°C of the specified classification temperature ( $T_c$ )	20 sec.	30 sec.
Ramp-down rate ( $T_p$ to $T_{smax}$ )	6°C/sec. max	6°C/sec. max
Time 25°C to peak temperature	6 min. max	8 min. max
Reflow cycles	2 max	2 max

\*Tolerance for peak profile temperature ( $T_p$ ) is defined as a supplier minimum and a user maximum.

\*\*Tolerance for time at peak profile temperature ( $t_p$ ) is defined as supplier minimum and a user maximum.

**Packaging**

**T = 1000 pcs/reel**

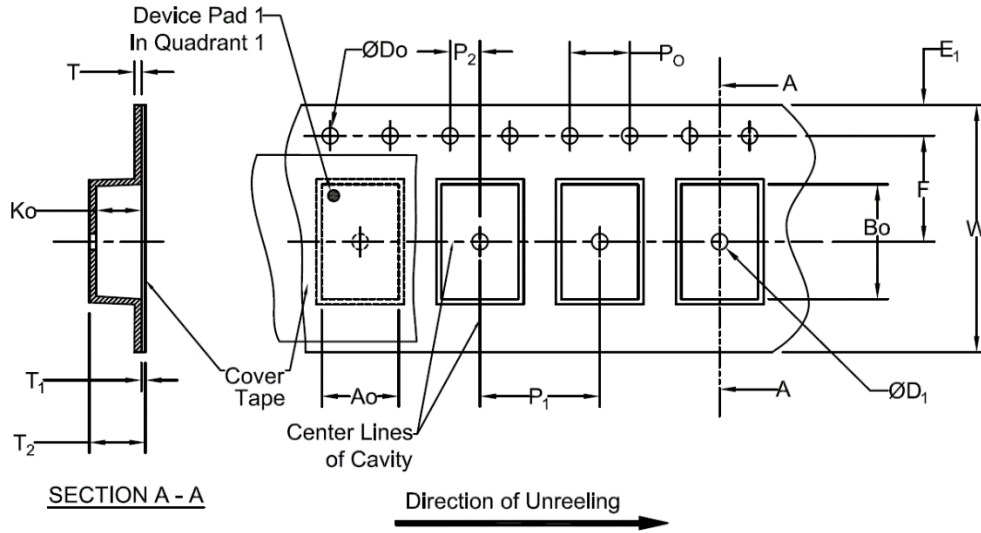

Tape Specifications (mm)							
Width	Ao	Bo	Do	D <sub>1</sub> (Min)	E <sub>1</sub>	F	Ko
16mm	*	*	1.5+0.1/-0.0	1.50	1.75±0.1	7.125	*
Width	P <sub>1</sub>	P <sub>2</sub>	P <sub>0</sub>	T (Max)	T <sub>1</sub> (Max)	T <sub>2</sub> (Max)	W (Max)
16mm	12.0±0.1	2.0±0.1	4.0±0.1	0.3	0.1	8.0	16.0

\*Note: Compliant to EIA-481

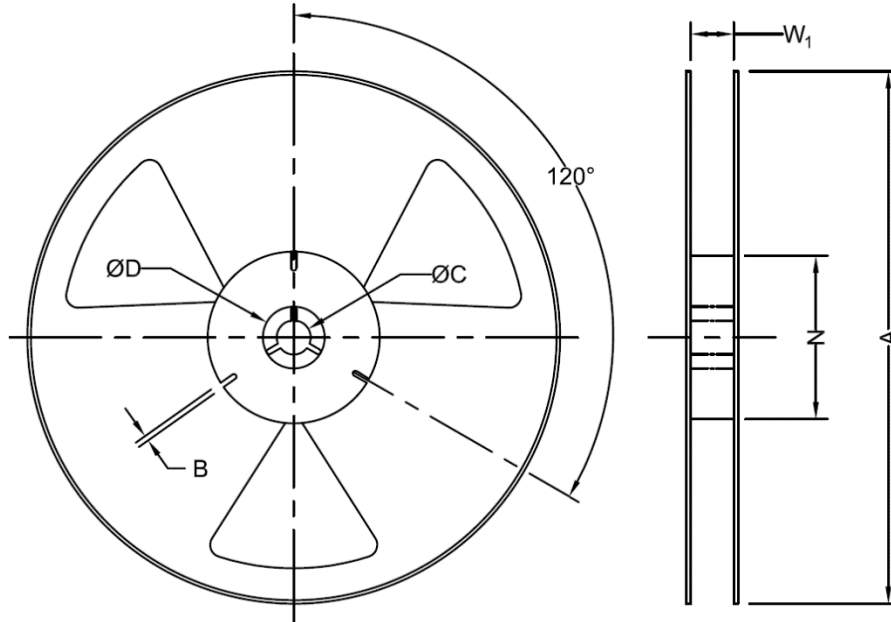

Reel Specifications (mm)							
Width	Qty/Reel	A	B	C	D	N	*W <sub>1</sub>
16mm	1000	330±1.0	2.5±0.3	13.0±0.2	22±0.6	99.5±0.5	16.8+1.0/-0.2

\*Note: Measured at Hub

## X-ON Electronics

Largest Supplier of Electrical and Electronic Components

*Click to view similar products for [OCXO Oscillators](#) category:*

*Click to view products by [Abracon](#) manufacturer:*

Other Similar products are found below :

[1380100-004](#) [8208AI23-33E26.000](#) [ABCM-60-10.000MHZ-BC-LG](#) [ABCM-60-10.000MHZ-BC-LN](#) [AOC1409VAUC-20.0000C](#)  
[AOC1409XAUC-20.0000C](#) [AOC2012VAJC-10.0000C](#) [AOC2012VAJC-12.8000C](#) [AOC2012VAJC-19.4400C](#) [AOC2012VAJC-25.0000C](#)  
[AOC2012XAJC-10.0000C](#) [AOC2012XAJC-12.8000C](#) [AOC2012XAJC-19.4400C](#) [AOC2012XAJC-25.0000C](#) [AOC2522BVAUC-10.0000](#)  
[AOC97FAJC-10.0000](#) [AOC97FAJC-20.0000](#) [AOCJY-100.000MHZ](#) [AOCJY-100.000MHz-E](#) [AOCJY-100.000MHz-F](#) [AOCJY-100.000MHZ-](#)  
[SW](#) [AOCJY-10.000MHz](#) [AOCJY-10.000MHz-E](#) [AOCJY-10.000MHz-F](#) [AOCJY1-100.000MHz](#) [AOCJY1-100.000MHz-E-SW](#) [AOCJY1-](#)  
[10.000MHz](#) [AOCJY1-10.000MHz-E-SW](#) [AOCJY-12.800MHZ](#) [AOCJY1-40.000MHz-E](#) [AOCJY1A-100.000MHz](#) [AOCJY1A-10.000MHz](#)  
[AOCJY-20.000MHz](#) [AOCJY-20.000MHz-F](#) [AOCJY2-100.000MHZ-E](#) [AOCJY2-100.000MHZ-E-SW](#) [AOCJY2-100.000MHz-F](#) [AOCJY2-](#)  
[100.000MHz-F-SW](#) [AOCJY2-10.000MHz](#) [AOCJY2-10.000MHZ-E](#) [AOCJY2-10.000MHZ-E-SW](#) [AOCJY2A-100.000MHz-E](#) [AOCJY2A-](#)  
[100.000MHz-F-SW](#) [AOCJY2A-10.000MHz-F-SW](#) [AOCJY3-100.000MHz-E-SW](#) [AOCJY3-10.000MHz](#) [AOCJY3A-100.000MHz-E](#)  
[AOCJY3A-100.000MHz-F](#) [AOCJY3A-10.000MHz](#) [AOCJY3A-10.000MHZ-E](#)