

# GPS Active Antenna Module - Adhesive Mount

## APAMP-108

RoHS/RoHS II compliant

Lead in copper alloy exemption (6c); and Lead in glass exemption (7c-1)



54.5 X 44.5 X 14.8mm

MSL level: Not Applicable

### FEATURES:

- High Reliability/ Sensitivity
- Compact Size
- Easy to install (adhesive tape base)
- ROHS Compliant

### TYPICAL APPLICATIONS:

- Automotive Navigation
- Automotive Monitoring
- Personal Tracking

### STANDARD SPECIFICATIONS:

#### Antenna

Parameters	Min.	Typ.	Max.	Units	Note
Center Frequency	1574.40	1575.42	1576.44	MHz	
Bandwidth	10.0			MHz	
VSWR			1.5:1		
Polarization Model	RHCP				(Right Hand Circular Polarization)
Impedance		50		Ω	
Gain		5		dBic	(Based on 70× 70mm ground plane)
Operating Temperature	-40		+80	°C	
Storage Temperature	-45		+85	°C	

#### Low Noise Amplifier (LNA)

Parameters	Min.	Typ.	Max.	Units	Note
Frequency	1574.40	1575.42	1576.44	MHz	
DC Voltage	3.0		5.0	V	
Gain	25	27	29	dB	(Without cable +25°C ± 10°C)
Out-of-band Rejection (Absolute Value)	25			dB	(fo+100MHz)
	40			dB	(fo-100MHz)
Output VSWR			2.0		
Noise Figure			1.5		(+25°C ± 10°C)
DC current		13.5	15.5	mA	(At 5.0V)

#### Overall (Complete Module including RF connector)

Parameters	Min.	Typ.	Max.	Units	Note
Frequency	1574.40	1575.42	1576.44	MHz	
Output VSWR			2.0		
Impedance		50		Ω	
Gain	25	27	29	dBic	(Based on 70× 70mm ground plane)

# GPS Active Antenna Module - Adhesive Mount

**APAMP-108**

RoHS/RoHS II compliant  
Lead in copper alloy exemption (6c); and Lead in glass exemption (7c-1)



54.5 X 44.5 X 14.8mm

## ANTENNA'S IMPEDANCE AND RETURN-LOSS CHARACTERISTICS

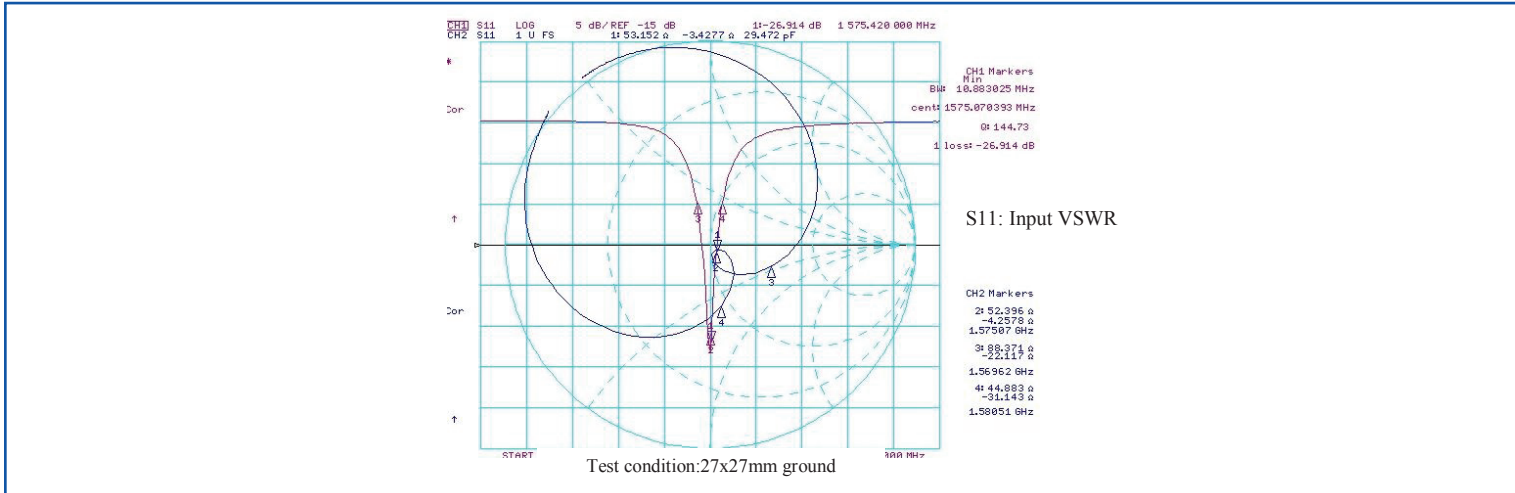

## LNA REFLECTION PROFILE

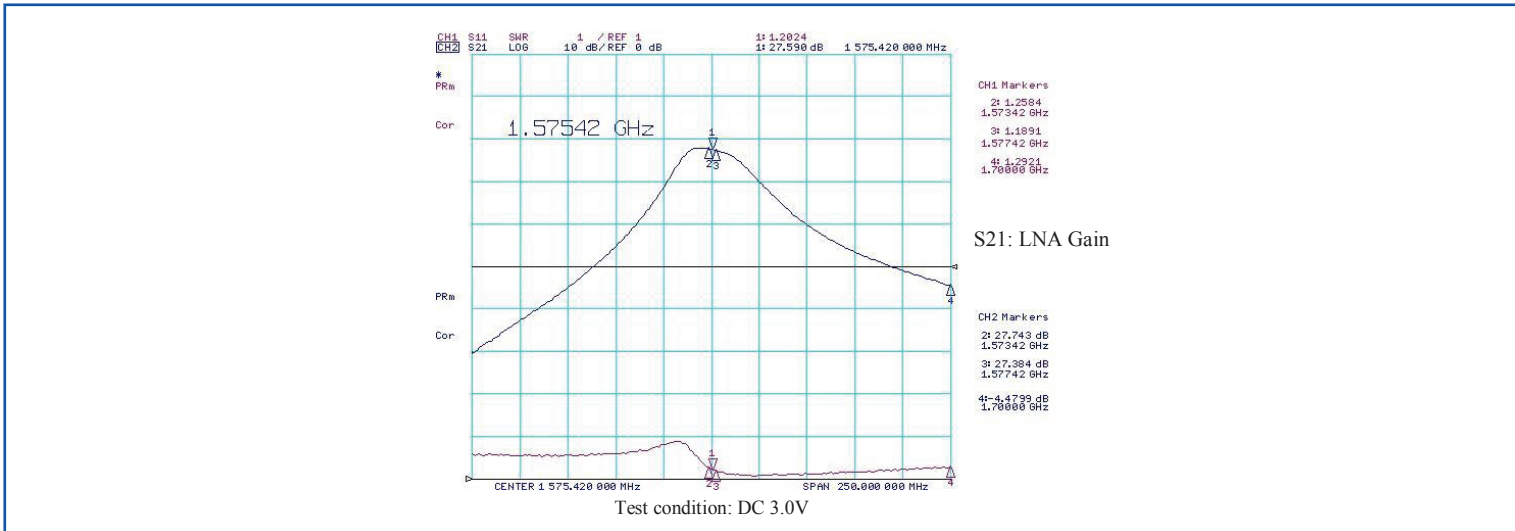

## OUTLINE DRAWING:

Top View

Side View

Parameters	Description
L (Cable Length)	300±10cm
Antenna	Dielectric Ceramic
RF Cable Attenuation	1.3 dB/m
PCB	FR4
RF Connector	SMA-J3
Shielding	Tinplate
Thickness	15.0mm
Mounting Type	Adhesive Tape

**Unit:mm**

ABRACON IS  
ISO9001:2008  
CERTIFIED



Visit [www.abracon.com](http://www.abracon.com) for Terms & Conditions of Sale **Revised: 10.24.14**  
30332 Esperanza, Rancho Santa Margarita, California 92688  
tel 949-546-8000 | fax 949-546-8001 | [www.abracon.com](http://www.abracon.com)

# GPS Active Antenna Module - Adhesive Mount

**APAMP-108**

RoHS/RoHS II compliant  
Lead in copper alloy exemption (6c); and Lead in glass exemption (7c-1)



54.5 X 44.5 X 14.8mm

## PRODUCT IMAGE:



## PACKAGING:

Each 475 x 215 x 215 mm size carton includes 100 pieces of antenna.



### CAUTION:

- (1) Do not apply excess mechanical stress to the component body or terminations. Do not attempt to re-form or bend the components as this will cause damage to the component.
- (2) Do not expose the component to open flame.
- (3) This specification applies to the functionality of the component as a single unit. Please insure the component is thoroughly evaluated in the application circuit.

**ATTENTION:** Abracon Corporation's products are COTS – Commercial-Off-The-Shelf products; suitable for Commercial, Industrial and, where designated, Automotive Applications. Abracon's products are not specifically designed for Military, Aviation, Aerospace, Life-dependant Medical applications or any application requiring high reliability where component failure could result in loss of life and/or property. For applications requiring high reliability and/or presenting an extreme operating environment, written consent and authorization from Abracon Corporation is required. Please contact Abracon Corporation for more information.

ABRACON IS  
ISO9001:2008  
CERTIFIED



Visit [www.abracon.com](http://www.abracon.com) for Terms & Conditions of Sale **Revised: 10.24.14**  
30332 Esperanza, Rancho Santa Margarita, California 92688  
tel 949-546-8000 | fax 949-546-8001 | [www.abracon.com](http://www.abracon.com)

## X-ON Electronics

Largest Supplier of Electrical and Electronic Components

*Click to view similar products for [Antennas](#) category:*

*Click to view products by [ABRACON](#) manufacturer:*

Other Similar products are found below :

[GAN30084EU](#) [930-033-R](#) [GW17.07.0250E](#) [1513563-1](#) [EXE902SM](#) [APAMPG-117](#) [MAF94383](#) [W3908B0100](#) [W6102B0100](#) [YE572113-](#)  
[30RSMM](#) [108-00014-50](#) [66089-2406](#) [A09-F8NF-M](#) [A09-F5NF-M](#) [RGFRA1903041A1T](#) [W3593B0100](#) [W3921B0100](#) [SIMNA-868](#) [SIMNA-](#)  
[915](#) [SIMNA-433](#) [W1044](#) [W1049B090](#) [A75-001](#) [WTL2449CQ1-FRSMM](#) [CPL9C](#) [EXB148BN](#) [0600-00060](#) [TRA9020S3PBN-001](#) [GD5W-](#)  
[28P-NF](#) [MA9-7N](#) [GD53-25](#) [GD5W-21P-NF](#) [EXB144SM](#) [C37](#) [MAF94051](#) [P1744](#) [MA9-5N](#) [EXD420PL](#) [B1322NR](#) [QWFTB120](#)  
[MAF94271](#) [MAF94300](#) [GPSMB301](#) [FG4403](#) [AO-AGSM-OM54](#) [5200232](#) [MIKROE-2349](#) [WCM.01.0111](#) [MIKROE-2393](#) [MIKROE-2352](#)