

CONTINUOUS VOLTAGE SMD CRYSTAL OSCILLATOR

ASCODV

Request Samples



Check Inventory



ESD Sensitive



1.60 x 1.20 x 0.80mm
RoHS/RoHS II Compliant
MSL Level = 1

Features

- Continuous Vdd operation from 1.6 V ~ 3.63 V
- Optimized for low current consumption
- Output Enable/Start & Disable/Stop function
- Output waveform CMOS/HCMOS/LVCMOS compatible
- Hermetically seam-sealed ceramic package

Applications

- Portable & wearable electronics
- Internet of Things (IoT)
- Consumer electronics
- Industrial control & automation
- Mobile communication

Electrical Specifications

Parameters	Min.	Typ.	Max.	Units	Notes
Frequency Range	1.25		50	MHz	
Operating Temperature Range	-40		+85	°C	See options
Storage Temperature Range	-55		+125	°C	
Overall Frequency Stability [Note 1]	-25		+25	ppm	See options
Supply Voltage (Vdd)	1.6		3.63	V	
Tri-state function	"1" (VIH≥0.7*Vdd) or Open: Oscillation; "0" (VIL<0.3*Vdd): No Oscillation/Hi Z			V	
Output Load			15	pF	CMOS
Output Voltage	VOH	0.9*Vdd		V	
	VOL		0.1*Vdd		
Aging 1 year @25°C±3°C	-3.0		+3.0	ppm	
Aging 5 years @25°C±3°C	-5.0		+5.0	ppm	
Symmetry @ ½ Vdd	45	50	55	%	
Start-up Time			5.0	ms	
Rise and Fall Time (Tr/Tf) @10% Vdd-90% Vdd, 15pF load	Vdd = 1.8V to 3.63V		8.0	ns	1.25MHz ≤ F ≤ 19.999MHz
			6.0		20MHz ≤ F ≤ 39.999MHz
			5.0		40MHz ≤ F ≤ 50MHz
	Vdd = 1.6V		10.0		1.25MHz ≤ F ≤ 19.999MHz
			8.0		20MHz ≤ F ≤ 39.999MHz
			6.0		40MHz ≤ F ≤ 50MHz
RMS Period Jitter @25°C±3°C	Vdd = 3.0V to 3.63V		5.0	ps	
	Vdd = 1.6V to 2.5V		7.0		
RMS Phase Jitter @25°C±3°C (10 - 39MHz: 12kHz to 5MHz) (>39MHz: 12kHz to 20MHz)			1.0	ps	Vdd = 3.3V
Disable Current			10.0	µA	

*Note 1: Overall frequency stability includes initial frequency tolerance @25°C±3°C and stability over the operating temperature range.



5101 Hidden Creek Ln Spicewood TX 78669
Phone: 512-371-6159 | Fax: 512-351-8858
For terms and conditions of sales, please visit:
www.abracon.com

REVISED: 05-12-23

ABRACON IS
ISO9001-2015
CERTIFIED

CONTINUOUS VOLTAGE SMD CRYSTAL OSCILLATOR

ASCODV

Request Samples



Check Inventory



ESD Sensitive



1.60 x 1.20 x 0.80mm
RoHS/RoHS II Compliant
MSL Level = 1

Electrical Specifications *continued*

Parameters	Min.	Typ.	Max.	Units	Notes
Supply Current (I _{dd}) into 15pF Load @25°C± 3°C @ V _{dd} =3.3V			2.0	mA	1.25MHz ≤ F ≤ 5.999MHz
			2.0		6MHz ≤ F ≤ 9.999MHz
			3.0		10MHz ≤ F ≤ 19.999MHz
			4.0		20MHz ≤ F ≤ 29.999MHz
			5.0		30MHz ≤ F ≤ 39.999MHz
			5.0		40MHz ≤ F ≤ 45.999MHz
			5.0		46MHz ≤ F ≤ 48.999MHz
			6.0		49MHz ≤ F ≤ 50MHz
	Supply Current (I _{dd}) into 15pF Load @25°C± 3°C @ V _{dd} =2.5V				1.3
			1.3	6MHz ≤ F ≤ 9.999MHz	
			2.0	10MHz ≤ F ≤ 19.999MHz	
			3.0	20MHz ≤ F ≤ 29.999MHz	
			3.5	30MHz ≤ F ≤ 39.999MHz	
			4.5	40MHz ≤ F ≤ 45.999MHz	
			4.5	46MHz ≤ F ≤ 48.999MHz	
			5.0	49MHz ≤ F ≤ 50MHz	
Supply Current (I _{dd}) into 15pF Load @25°C± 3°C @ V _{dd} =1.8V				1.0	mA
			1.0	6MHz ≤ F ≤ 9.999MHz	
			1.6	10MHz ≤ F ≤ 19.999MHz	
			2.2	20MHz ≤ F ≤ 29.999MHz	
			2.5	30MHz ≤ F ≤ 39.999MHz	
			3.0	40MHz ≤ F ≤ 45.999MHz	
			3.5	46MHz ≤ F ≤ 48.999MHz	
			3.5	49MHz ≤ F ≤ 50MHz	



5101 Hidden Creek Ln Spicewood TX 78669
Phone: 512-371-6159 | Fax: 512-351-8858
For terms and conditions of sales, please visit:
www.abracon.com

REVISED: 05-12-23

ABRACON IS
ISO9001-2015
CERTIFIED

CONTINUOUS VOLTAGE SMD CRYSTAL OSCILLATOR

ASCODV

Request Samples



Check Inventory



ESD Sensitive



1.60 x 1.20 x 0.80mm
RoHS/RoHS II Compliant
MSL Level = 1

Typical Current Consumption (I_{dd}) vs. Supply Voltage (V_{dd}) Characteristics @ 25°C ± 3°C [Load = 15pF]

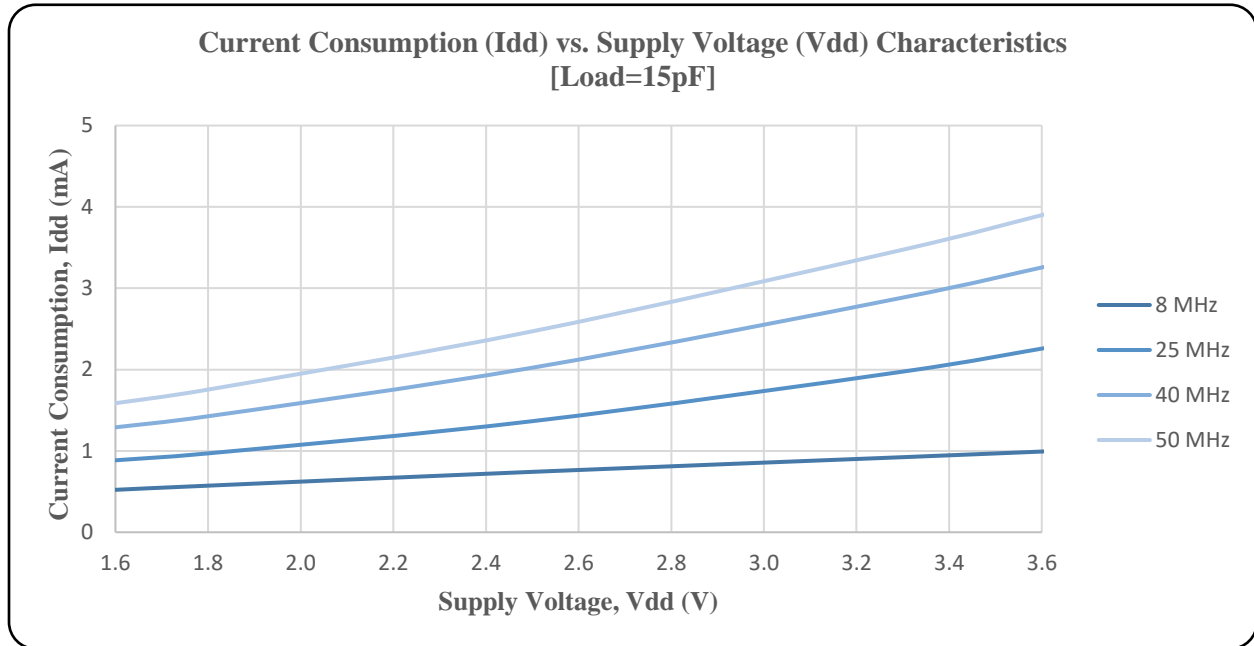

Typical Frequency vs. Supply Voltage (V_{dd}) Characteristics @ 25°C ± 3°C

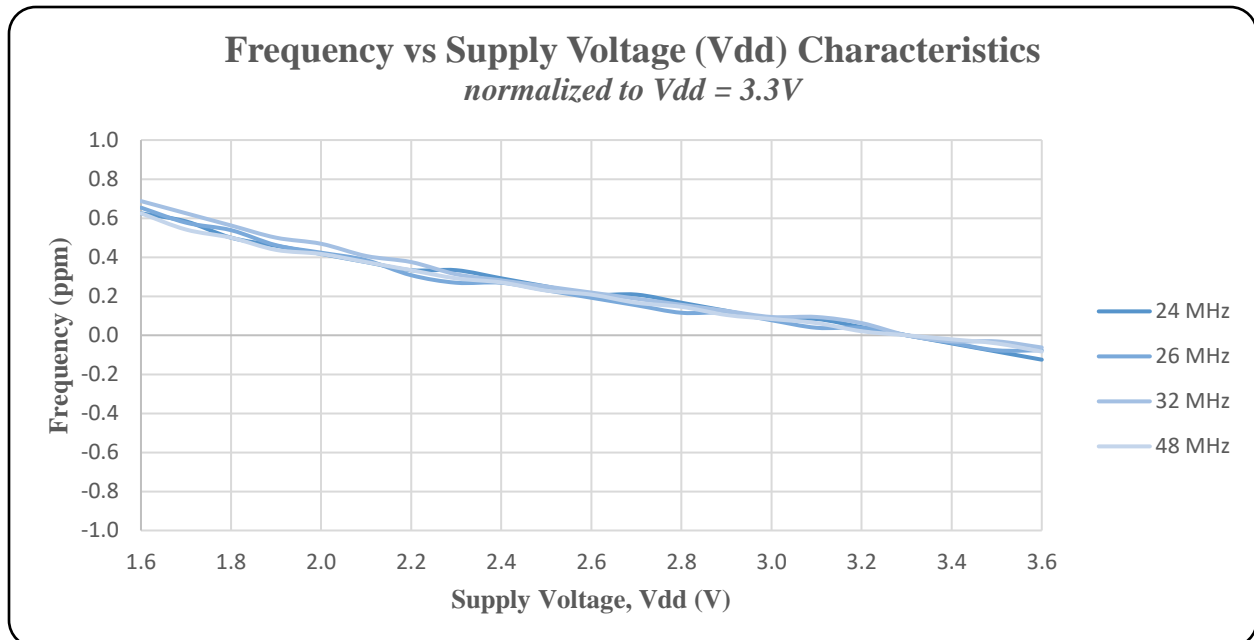

5101 Hidden Creek Ln Spicewood TX 78669
Phone: 512-371-6159 | Fax: 512-351-8858
For terms and conditions of sales, please visit:
www.abracon.com

REVISED: 05-12-23

ABRACON IS
ISO9001-2015
CERTIFIED

CONTINUOUS VOLTAGE SMD CRYSTAL OSCILLATOR

ASCODV

Request Samples



Check Inventory



ESD Sensitive



1.60 x 1.20 x 0.80mm
RoHS/RoHS II Compliant
MSL Level = 1

Typical Frequency vs. Temperature Characteristics @ Vdd = 3.3V [Load = 15pF]

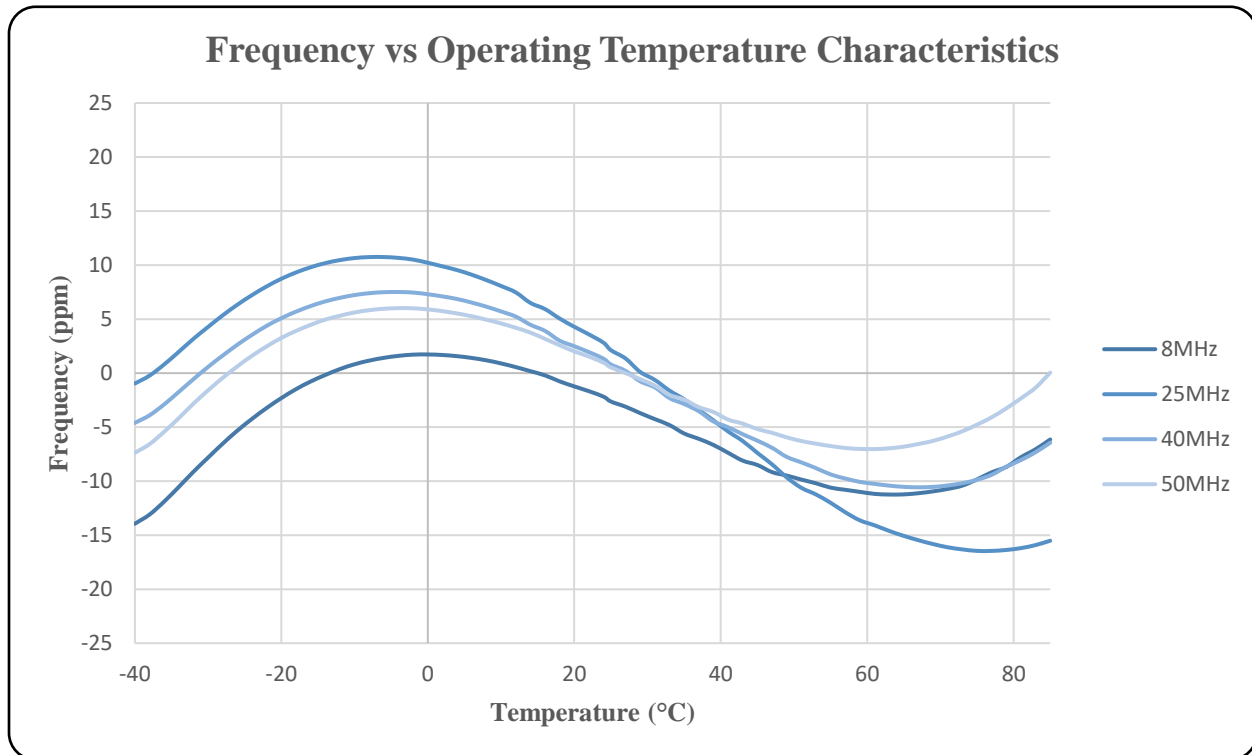

Part Identification

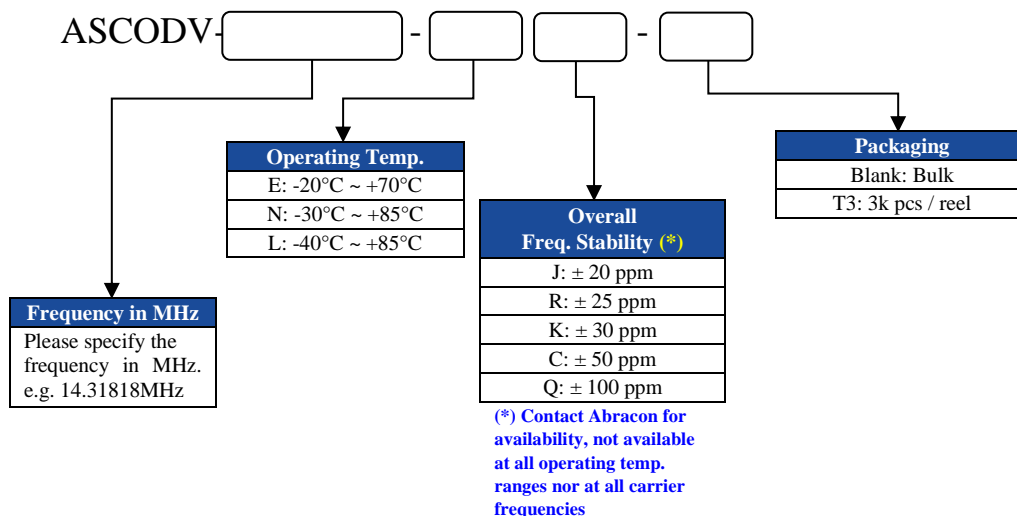

5101 Hidden Creek Ln Spicewood TX 78669
Phone: 512-371-6159 | Fax: 512-351-8858
For terms and conditions of sales, please visit:
www.abracon.com

REVISED: 05-12-23

ABRACON IS
ISO9001-2015
CERTIFIED

CONTINUOUS VOLTAGE SMD CRYSTAL OSCILLATOR

ASCODV

Request Samples



Check Inventory



ESD Sensitive



1.60 x 1.20 x 0.80mm
RoHS/RoHS II Compliant
 MSL Level = 1

Mechanical Dimensions

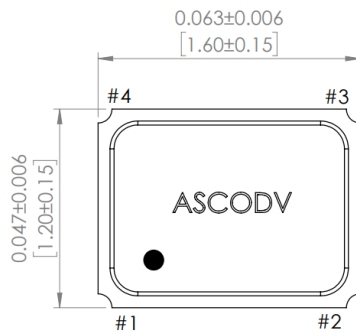

TOP VIEW

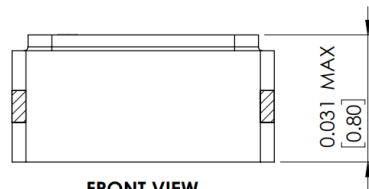

FRONT VIEW

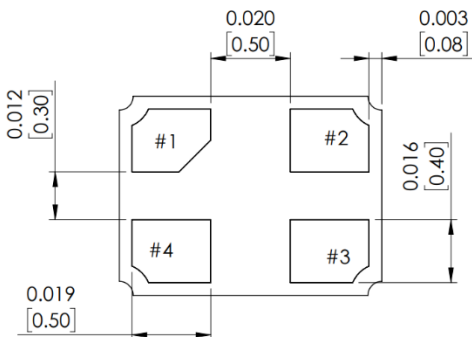

BOTTOM VIEW

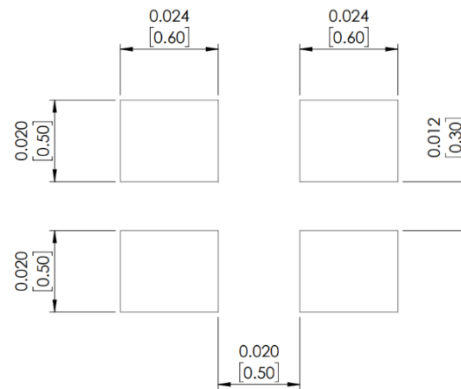

Recommended land pattern

Pin #	Function
1	Tri-State
2	GND
3	Output
4	Vdd

Note: Recommended to use approximately 0.01µF bypass capacitor between PIN 2 and PIN 4

Dimensions: inches [mm]



5101 Hidden Creek Ln Spicewood TX 78669
 Phone: 512-371-6159 | Fax: 512-351-8858
 For terms and conditions of sales, please visit:
www.abracon.com

REVISED: 05-12-23

ABRACON IS
 ISO9001-2015
 CERTIFIED

CONTINUOUS VOLTAGE SMD CRYSTAL OSCILLATOR

ASCODV

Request Samples



Check Inventory



1.60 x 1.20 x 0.80mm
RoHS/RoHS II Compliant
MSL Level = 1



ESD Sensitive



Reflow Profile [JEDEC J-STD-020]

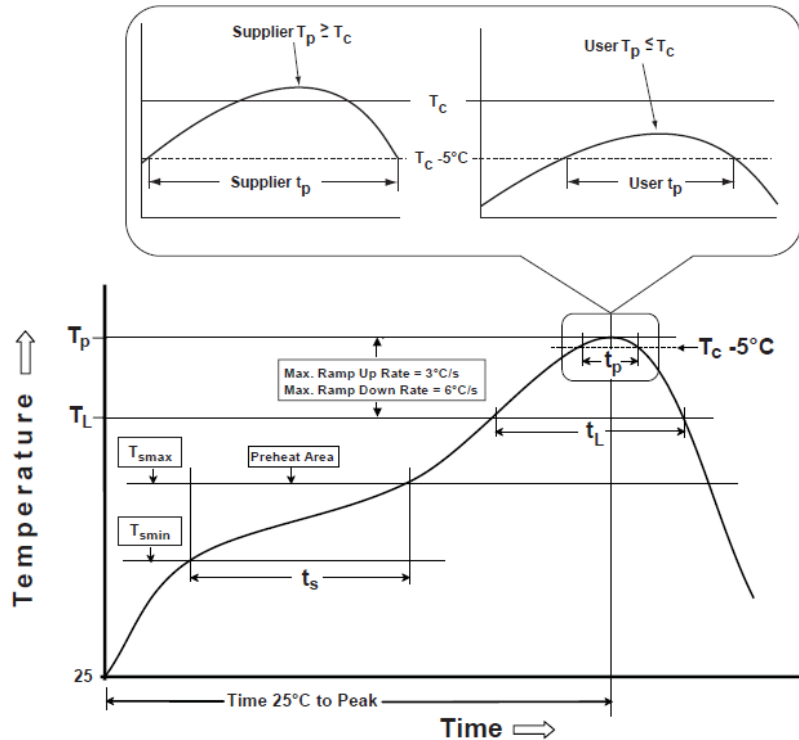

Table 1

SnPb Eutectic Process
Classification Temperatures (T_c)

Package Thickness	Volume mm ³ <350	Volume mm ³ ≥350
<2.5 mm	235 °C	220 °C
≥2.5 mm	220 °C	220 °C

Table 2

Pb-Free Process
Classification Temperatures (T_c)

Package Thickness	Volume mm ³ <350	Volume mm ³ 350-2000	Volume mm ³ >2000
<1.6 mm	260 °C	260 °C	260 °C
1.6 mm - 2.5 mm	260 °C	250 °C	245 °C
>2.5 mm	250 °C	245 °C	245 °C

Profile Feature	Sn-Pb Eutectic Assembly	Pb-Free Assembly
Preheat / soak		
Temperature minimum (T_{smin})	100°C	150°C
Temperature maximum (T_{smax})	150°C	200°C
Time (T_{smin} to T_{smax}) (t_s)	60 - 120 sec.	60 - 120 sec.
Average ramp-up rate (T_{smax} to T_p)	3°C/sec. max	3°C/sec. max
Liquidous temperature (T_L)	183°C	217°C
Time at liquidous (t_L)	60 - 150 sec.	60 - 150 sec.
Peak package body temperature (T_p)*	see Table 1	see Table 2
Time (t_p)** within 5°C of the specified classification temperature (T_c)	20 sec.	30 sec.
Ramp-down rate (T_p to T_{smax})	6°C/sec. max	6°C/sec. max
Time 25°C to peak temperature	6 min. max	8 min. max
Reflow cycles	2 max	2 max

*Tolerance for peak profile temperature (T_p) is defined as a supplier minimum and a user maximum.

**Tolerance for time at peak profile temperature (t_p) is defined as supplier minimum and a user maximum.



5101 Hidden Creek Ln Spicewood TX 78669
Phone: 512-371-6159 | Fax: 512-351-8858
For terms and conditions of sales, please visit:
www.abracon.com

REVISED: 05-12-23

ABRACON IS
ISO9001-2015
CERTIFIED

CONTINUOUS VOLTAGE SMD CRYSTAL OSCILLATOR

ASCODV

Request Samples



Check Inventory



1.60 x 1.20 x 0.80mm
RoHS/RoHS II Compliant
MSL Level = 1



Packaging

T3: 3,000pcs/reel

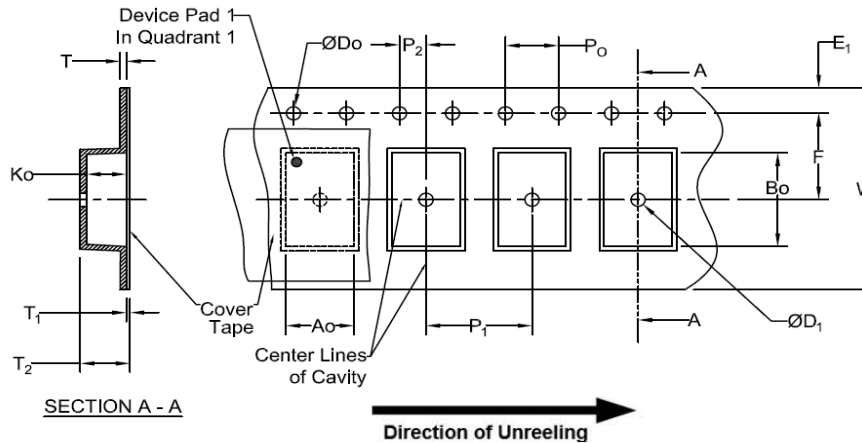

Tape Specifications (mm)							
Width	Ao	Bo	Do	D ₁ (Min)	E ₁	F	Ko
8mm	*	*	1.5+0.1/-0.0	1.0	1.75±0.1	3.5±0.05	*
Width	P ₁	P ₂	P ₀	T (Max)	T ₁ (Max)	T ₂ (Max)	W (Max)
8mm	4.0±0.1	2.0±0.05	4.0±0.1	0.6	0.1	2.5	8.3

*Note: Compliant to EIA-481

Dimensions: inches (mm)

ATTENTION: Abracon LLC's products are COTS – Commercial-Off-The-Shelf products; suitable for Commercial, Industrial and, where designated, Automotive Applications. Abracon's products are not specifically designed for Military, Aviation, Aerospace, Life-dependent Medical applications or any application requiring high reliability where component failure could result in loss of life and/or property. For applications requiring high reliability and/or presenting an extreme operating environment, written consent and authorization from Abracon LLC is required. Please contact Abracon LLC for more information.



5101 Hidden Creek Ln Spicewood TX 78669
Phone: 512-371-6159 | Fax: 512-351-8858
For terms and conditions of sales, please visit:
www.abracon.com

REVISED: 05-12-23

ABRACON IS
ISO9001-2015
CERTIFIED

CONTINUOUS VOLTAGE SMD CRYSTAL OSCILLATOR

ASCODV

Request Samples



Check Inventory



ESD Sensitive



1.60 x 1.20 x 0.80mm
RoHS/RoHS II Compliant
MSL Level = 1

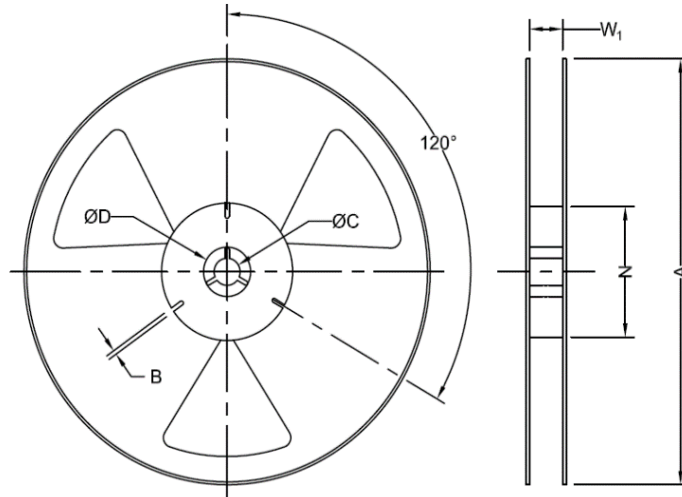

Unit: mm

Tape Specifications (mm)							
Suffix	Qty/Reel	A (Nom)	B (Min)	C (Min)	D (Min)	N (Min)	* W_1
-T3	3000	178	1.5	13.0+0.5/-0.2	20.2	50	8.4+1.5/-0.0

X-ON Electronics

Largest Supplier of Electrical and Electronic Components

Click to view similar products for [Standard Clock Oscillators](#) category:

Click to view products by [Abracon](#) manufacturer:

Other Similar products are found below :

[601252](#) [F335-25](#) [F535L-33.333](#) [F535L-50](#) [NBXHBA019LN1TAG](#) [SiT1602BI-22-33E-50.000000E](#) [SIT8918AA-11-33S-50.000000G](#)
[SM4420TEV-40.0M-T1K](#) [F335-24](#) [F335-40](#) [F535L-10](#) [F535L-12](#) [F535L-24](#) [F535L-27](#) [PE7744DW-100.0M](#) [ASF1-3.686MHZ-N-K-S](#) [ASV-](#)
[4.000MHZ-LCS-T](#) [XLH735025.000JU4I8](#) [XLP725125.000JU6I8](#) [XO57CTECNA3M6864](#) [601251](#) [SiT8503AI-18-33E-0.200000X](#)
[SIT8918AA-11-33S-16.000000G](#) [SIT9122AI2C233E300.000000X](#) [9120AC-2D2-33E212.500000](#) [9102AI-243N25E100.00000](#) [8208AC-82-](#)
[18E-25.00000](#) [8008AI-72-XXE-24.545454E](#) [8004AC-13-33E-133.33000X](#) [AS-4.9152-16-SMD-TR](#) [ASFL1-48.000MHZ-LC-T](#)
[632L3I004M00000](#) [SIT8920AM-31-33E-25.0000](#) [DSC1028DI2-019.2000](#) [9121AC-2C3-25E100.00000](#) [9102AI-233N33E100.00000X](#)
[9102AI-233N25E200.00000](#) [9102AI-232H25S125.00000](#) [9102AI-133N25E200.00000](#) [9102AC-283N25E200.00000](#) [9001AC-33-33E1-30.000](#)
[8103AC-13-33E-12.00000X](#) [3921AI-2CF-33NZ125.000000](#) [5730-1SF](#) [XUN736000.032768I](#) [ASV-25.000MHZ-ECS-50-T](#) [EC3925ETTTS-](#)
[100.000M TR](#) [SIT1602BC-83-33E-10.000000Y](#) [8003AI-12-33S-40.00000Y](#) [1602BI-13-33S-19.200000E](#)