

FEATURES:

- Low Power Consumption <10mA
- Exceptional Stability Over Temp. at -40 to +85°C.
- Available over Extended Operating Temperature
- Low Cost-Compact QFN Plastic Packaging
- Compact Package design

APPLICATIONS:

- CCD Clock for VTR Camera
- Equipment Connected to PCs
- Low Profile Equipment
- Lower Cost Crystal Oscillator Replacement
- Computers and Peripherals
- Portable Electronics (MP3 Players, Games)
- Consumer Electronics such as TV's, DVR's, etc.
- Vibrant, Shock-Prone & Humid Environments for Industrial Equipment
- Demanding Military & Automotive Electronics

STANDARD SPECIFICATIONS:

Parameters		Minimum	Typical	Maximum	Units	Notes
Frequency Range:		1.0	-----	150	MHz	
Operating Temperature:		0	-----	+70	°C	See options
Storage Temperature:		-55	-----	+150	°C	
Overall Frequency Stability*:		-100	-----	+100	ppm	See options
Supply Voltage (Vdd):		+1.8 ~ +3.3			V	See options
Supply Current (no load):	1.0 to 39.9999MHz	-----	3	10	mA	No load RL=∞ T=25°C
	40.0 to 79.9999MHz	-----	4	10		
	80.0 to 124.9999MHz	-----	5	10		
	125.0 to 150MHz	-----	6	10		
Output Voltage:	V _{OH}	0.8*V _{dd}	-----	-----	V	15pF
	V _{OL}	-----	-----	0.2*V _{dd}		
Rise Time:	Tr	-----	1.3	2.0	ns	15pF; T=25°C 20%/80%*VDD
Fall Time:	Tf	-----	1.3	2.0		
Output Load:		15pF max / 10kΩ min.			pF	See options
Symmetry:		45	-----	55	%	@1/2Vdd
Startup Time:		-----	1.5	3.0	ms	
Disable Time:		-----	20	100	ns	
Disable Stand-by Current:		-----	-----	1	uA	
Tri-state Function (Stand-by) :		"1" (VIH≥0.75*Vdd) or Open: Oscillation "0" (VIH<0.25*Vdd) : Hi Z			V	
Cycle to cycle jitter:		-----	95	-----	ps	F=100MHz
Aging:		-5.0	-----	+5.0	ppm	First year

Absolute Maximum Ratings

Item	Minimum	Maximum	Unit	Condition
Supply Voltage	-0.3	+4.0	V	
Input Voltage	-0.3	Vdd+0.3	V	
Junction Temp.	-----	+150	°C	
Soldering Temp.	-----	+260	°C	40sec max
ESD	HBM	2,000	V	
	MM	200		
	CDM	500		



> PART NUMBER FOR PROGRAMMED ORDERS (Quantity > 1,000pcs)

ASEM - MHz - -

Supply Voltage
1: 3.3 ± 0.3V
2: 3.0 ± 0.3V
3: 2.5 ± 0.2V
4: 1.8 ± 0.15V
5: 2.8 ± 0.2V

Frequency in MHz
e.g. 14.3181 MHz (Maximum 4 digits after decimal)

Operating Temp.
Blank: 0°C ~ +70°C
E: -20°C ~ +70°C
L: -40°C ~ +85°C

Overall Freq. Stability
Blank: ±100ppm
R: ±25ppm
C: ±50ppm

Packaging
Blank*: 110pcs / Tube
T: 1,000pcs / reel
T3: 3,000pcs / reel
T5: 5,000pcs / reel

* For Quick turn-around programmable orders < 1000pcs: Due to the immediate availability of stock and the qty of the order, the parts may be delivered as BULK: Cut Tape, Loose parts in Antistatic Bag or in Tube(s). The MOQ per the series will still apply for Tube packaging.

Un-Programmed Orders (Quantity < 1,000pcs)

Blank un-programmed oscillators are available for quick turn engineering requirements. Please call ABRACON for more information.

ASEM - BLANK - -

Operating Temp. Freq. Stability
EC: ± 50 ppm / -20°C to +70°C
ER: ± 25 ppm / -20°C to +70°C
LC: ± 50 ppm / -40°C to +85°C
LR: ± 25 ppm / -40°C to +85°C

Packaging
Blank: 110pcs / Tube
T: 1,000pcs / reel
T3: 3,000pcs / reel
T5: 5,000pcs / reel

MEMS CLOCK OSCILLATOR

ASEM



Life Size

3.2 x 2.5 x 0.85 mm

ASEM

Pb | RoHS/RoHS II Compliant

OUTLINE DRAWING:

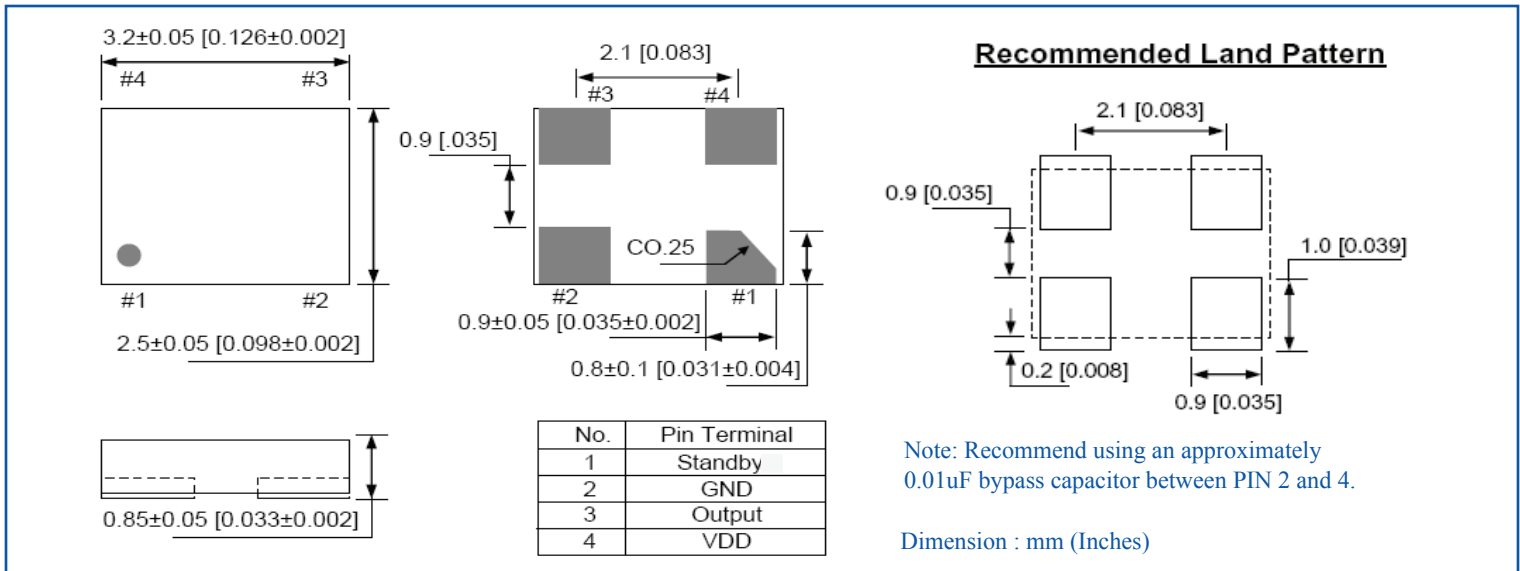

TAPE & REEL: Tape and reel 1,000pcs/reel

REFLOW PROFILE:

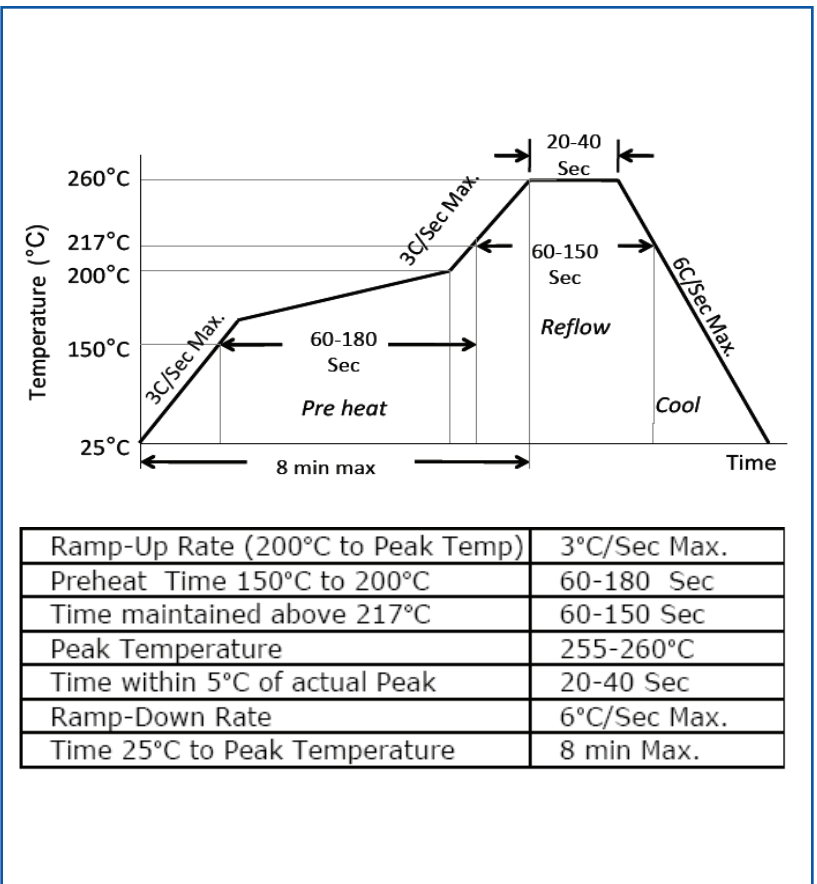
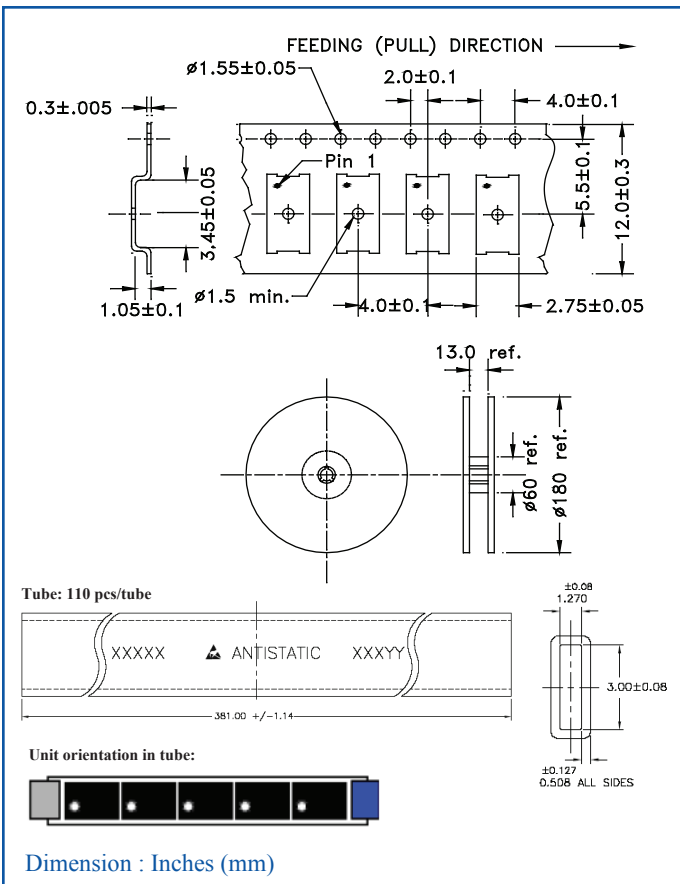

Need a test socket for the ASEM Series? To view compatible **PRECISION TEST & BURN-IN SOCKETS** for these parts, [click here](#). P/N: **AXS-3225-04-02**

ATTENTION: Abracon LLC's products are COTS – Commercial-Off-The-Shelf products; suitable for Commercial, Industrial and, where designated, Automotive Applications. Abracon's products are not specifically designed for Military, Aviation, Aerospace, Life-dependent Medical applications or any application requiring high reliability where component failure could result in loss of life and/or property. For applications requiring high reliability and/or presenting an extreme operating environment, written consent and authorization from Abracon LLC is required. Please contact Abracon LLC for more information.

X-ON Electronics

Largest Supplier of Electrical and Electronic Components

Click to view similar products for [Programmable Oscillators](#) category:

Click to view products by [ABRACON](#) manufacturer:

Other Similar products are found below :

[8N4Q001LG-0102CDI](#) [8N4Q001LG-0139CDI](#) [DSC8101AL2](#) [8N0Q001BH-2202CDI](#) [DSC8101DI5](#) [DSC8121AI5](#) [EP16E7E2H26.000MTR](#)
[SIT8102AI-13-18E-25.00000T](#) [8N4Q001LG-1033CDI](#) [DSC8121CL5T](#) [DS1090U-2/V+T](#) [DS1090U-32+T](#) [DSC8121AM2](#) [DSC8001AL2](#)
[DSC8101BL2](#) [DSC8121CI1](#) [DSC8124CI5](#) [DSC8003CI2T](#) [DSC8102DI2](#) [DSC8124CI2](#) [DSC8123CI5](#) [DSC8124BI2](#) [DSC8122BI5](#)
[DSC8101DI2](#) [DSC8121CL5](#) [SG-8002JA 20.000M-PTMB-ROHS](#) [ECS-P143-10-AN](#) [570FCC001204DG](#) [570FCC000169DG](#)
[544BAEB002025CBG](#) [544BAHB002172BBGR](#) [544BAHB002157BBGR](#) [DS1077LU-40+T](#) [SiT3808AI-D2-XXXX-000.FP000X](#) [DS1090U-](#)
[1+T](#) [DS1086Z+T&R](#) [DS1087LU-447+T](#) [544BCAA000112BBG](#) [DS1086LU+T](#) [564BACA001478ABG](#) [SG-8002CA 2.4576M-PCBB](#)
[564BACA000121ABG](#) [564BACA001478BBG](#) [564BABA002053ABG](#) [564BAAA000121ABG](#) [564BAAC000115BBG](#)
[564BAAD000115BBG](#) [ECS-P8F3X-1.000-AN](#) [570CBC000306DG](#) [SiT8008AC-33-18E-33.333330](#)