

# Programmable - High Performance SMD XO & VCXO

## ASG-P Series

Moisture Sensitivity Level (MSL) - This product is Hermetically Sealed and not Moisture Sensitive; therefore MSL = N/A (Not Applicable)



RoHS  
Compliant



7.0 x 5.0 x 1.9mm

### FEATURES:

- ASG series is a High Performance crystal based oscillator; available either as an XO or a VCXO
- Frequency range from 10MHz to 250MHz with LVCMOS output
- Available from 10MHz to 1.50GHz with LVDS or LVPECL output
- Offered with either 2.50V or 3.30V bias voltage
- Quick turn, 1~5 business days for small quantity orders

### APPLICATIONS:

- Networking, SONET/SDH
- WiMax / WLAN
- Computing
- Phase Locked Loops
- Direct Digital Synthesis (DDS)
- DSL/ADSL
- Base Terminal Stations

### STANDARD SPECIFICATIONS:

Parameters		Minimum	Typical	Maximum	Units	Notes
Frequency Range:	V <sub>dd</sub> = 3.3V	10		1500	MHz	
	V <sub>dd</sub> = 2.5V	10		1500	MHz	
Operating Temperature:		-40		+85	°C	
Storage Temperature:		-55		+125	°C	
Overall Frequency Stability:		-50		+50	ppm	<i>See Note # 1</i>
Initial Set Tolerance		-5.00	≤ ±1.00	+5.00	ppm	
Stability over operating temperature		-35.00	≤ ±20.00	+35.00	ppm	
Aging @ 25°C over 10-years		-7.00		+7.00	ppm	
Frequency variation over supply voltage change (±5%)		-2.00		+2.00	ppm	
Frequency variation over load variation (15pF ± 5%)		-1.00		+1.00	ppm	
Supply Voltage (V <sub>dd</sub> ):	V <sub>dd</sub> = 3.3V	3.135	3.300	3.465	V	
	V <sub>dd</sub> = 2.5V	2.375	2.500	2.625	V	
Input Current:	V <sub>dd</sub> = 3.3V		< 54	60	mA	Frequency dependent
	V <sub>dd</sub> = 2.5V		< 50	60	mA	Frequency dependent
LVPECL Output (Out & $\overline{Out}$ ):	Output High Voltage V <sub>OH</sub>	V <sub>dd</sub> - 1.03		V <sub>dd</sub> - 0.60	V	V <sub>OH</sub>
	Output Low Voltage V <sub>OL</sub>	V <sub>dd</sub> - 1.85		V <sub>dd</sub> - 1.60	V	V <sub>OL</sub>
	Differential Duty Cycle	45	48/52	55	%	DODC <sub>LVPECL</sub>
	Rise Time	150		350	ps	t <sub>R</sub>
	Fall Time	150		350	ps	t <sub>F</sub>
Start-up Time:			≤ 2.0	3.0	ms	
Enable/Disable Function :		"1" (V <sub>IH</sub> ≥ 0.7*V <sub>dd</sub> ) or Open: Oscillation "0" (V <sub>IL</sub> < 0.3*V <sub>dd</sub> ) : High Z				
V <sub>control</sub> Range		0.00		V <sub>dd</sub>	Volts	For VCXO
Frequency Pull		±50			ppm	
Control Port Bandwidth		10			kHz	
Phase jitter RMS [ t <sub>jitt</sub> ( ) ] <i>See Note #2</i>	Integer Mode		< 0.60	1.60	ps	12kHz to 20MHz
	Fractional Mode		< 0.90	1.60	ps	12kHz to 20MHz

**Note #1:** Inclusive of initial tolerance at 25°C±3°C, operating temperature range, input voltage variation, load variation & aging.

**Note #2:** The rms jitter over 12kHz to 20MHz Bandwidth is dependent on the carrier and whether or not the final frequency is achieved without engaging the Fractional Mode

ABRACON IS  
ISO9001:2008  
CERTIFIED



**ABRACON**  
CORPORATION

Visit [www.abracon.com](http://www.abracon.com) for Terms & Conditions of Sale **Revised: 04.27.12**  
30332 Esperanza, Rancho Santa Margarita, California 92688  
tel 949-546-8000 | fax 949-546-8001 | [www.abracon.com](http://www.abracon.com)

# Programmable - High Performance SMD XO & VCXO

ASG-P Series



RoHS  
Compliant



7.0 x 5.0 x 1.9mm

## OVERALL SYSTEM BLOCK DIAGRAM

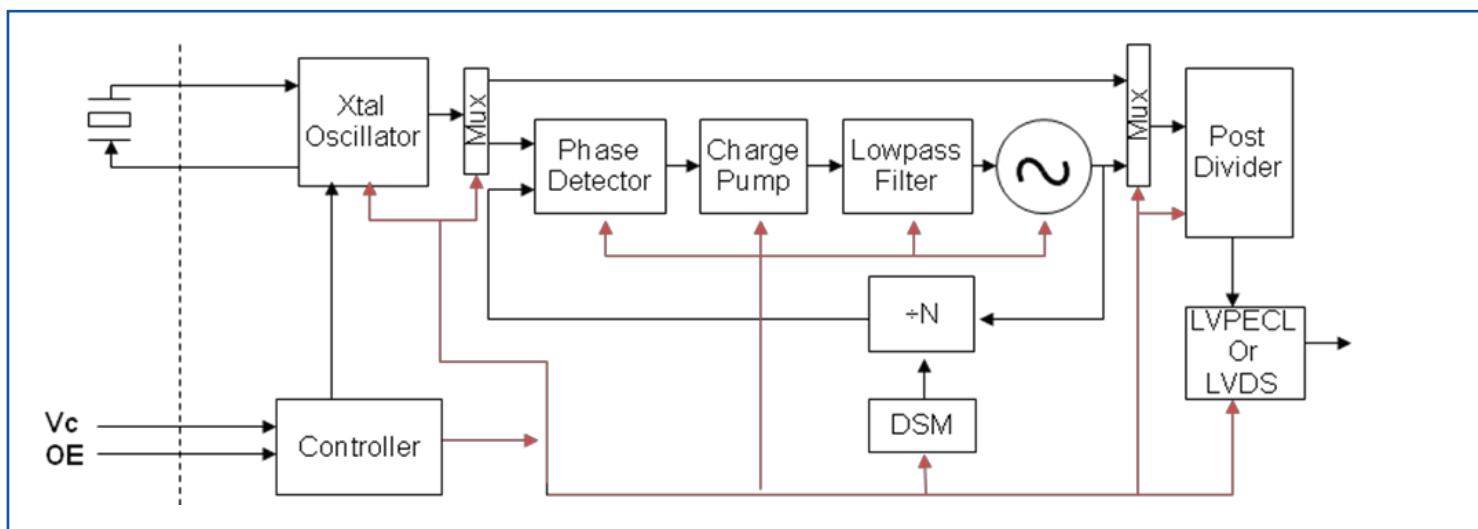

## PHASE NOISE & JITTER CHARACTERISTICS

622.88MHz Carrier

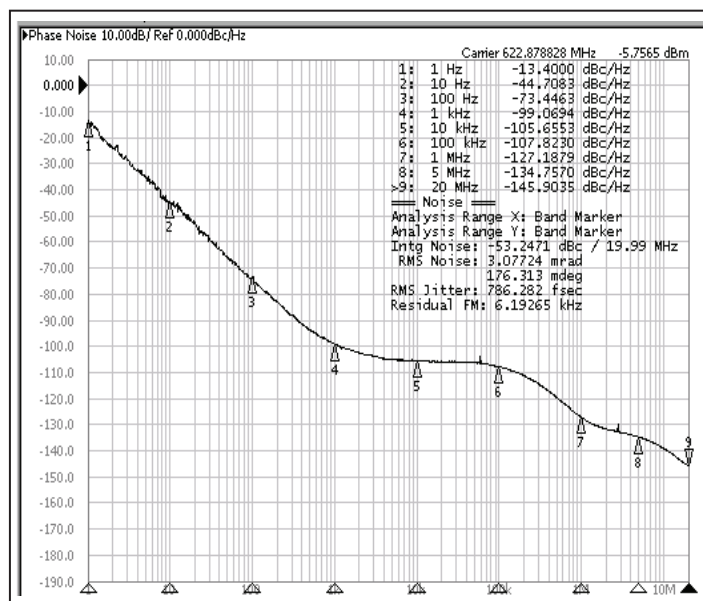

1.50GHz Carrier

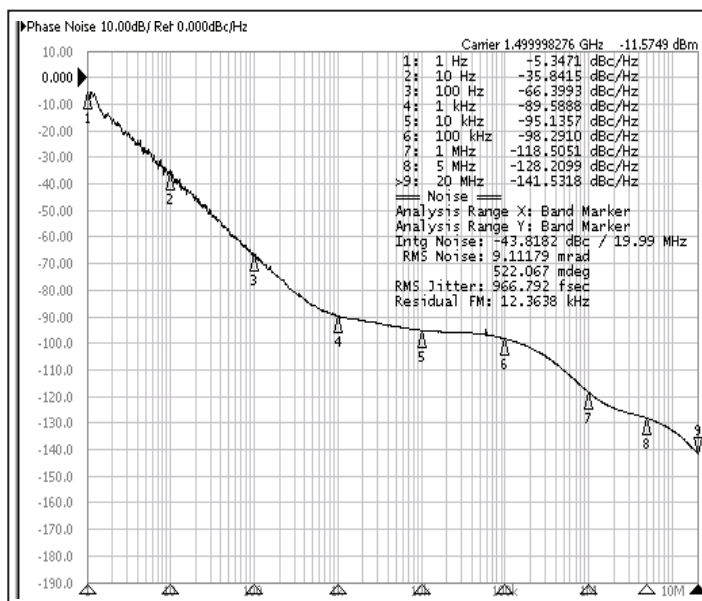

# Programmable - High Performance SMD XO & VCXO

ASG-P Series



RoHS  
Compliant



7.0 x 5.0 x 1.9mm

## FREQUENCY STABILITY VS. TEMPERATURE

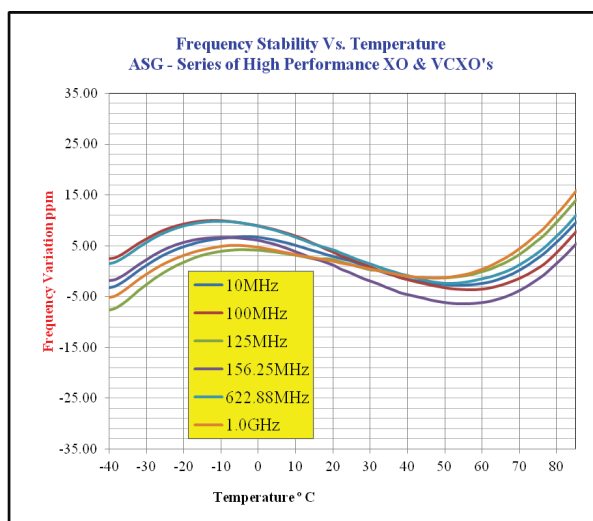

## FREQUENCY PULLING VS. CONTROL VOLTAGE (VCXO MODE)

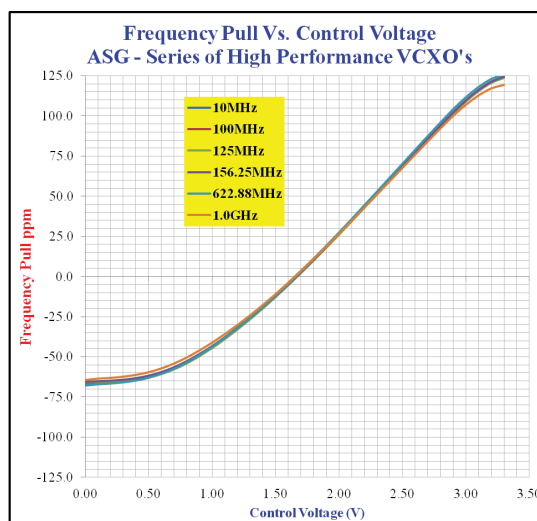

## PART IDENTIFICATION:

ASG - P - [ ] - [ ] - [ ] MHz - [ ]

**Fixed or Pull-able**

X = Fixed Oscillator

V = VCXO

**Operating Voltage**

3.30V = A

2.50V = B

**Frequency in MHz**

Please specify the  
Frequency in MHz  
e.g. 100.000 MHz

**Packaging**

Blank = Bulk

T = Tape & Reel

## MARKING:

**Top Line:**

**Bottom Line:**

**Pin# 1 Identifier**

ASG  
GYWW

**WW = Work Week**

**Year Code (B=2011, C=2012, etc.)**

**Internal Tracking Code**

ABRACON IS  
ISO9001:2008  
CERTIFIED



**ABRACON**  
CORPORATION

Visit [www.abracon.com](http://www.abracon.com) for Terms & Conditions of Sale **Revised: 04.27.12**  
30332 Esperanza, Rancho Santa Margarita, California 92688  
tel 949-546-8000 | fax 949-546-8001 | [www.abracon.com](http://www.abracon.com)

# Programmable - High Performance SMD XO & VCXO

ASG-P Series



RoHS  
Compliant



7.0 x 5.0 x 1.9mm

## OUTLINE DIMENSIONS:

Pin #	Pin Description For VCXO configuration
1	Voltage Control for VCXO
2	Output Enable (OE)
3	GND
4	RF Output
5	RF $\overline{\text{Output}}$
6	Vdd

Pin #	Pin Description For XO configuration
1	Output Enable (OE)
2	N/C for XO
3	GND
4	RF Output
5	RF $\overline{\text{Output}}$
6	Vdd

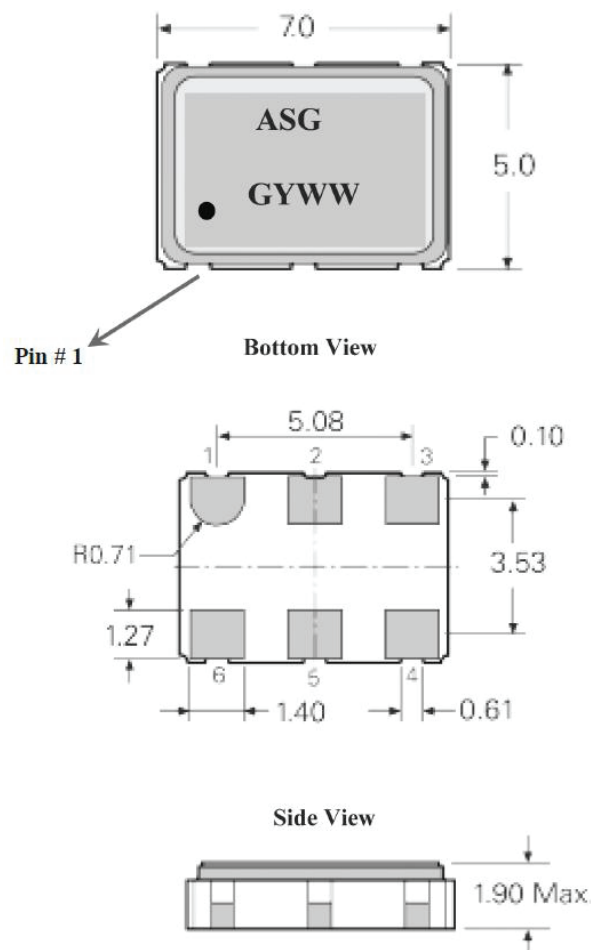

## REFLOW PROFILE:

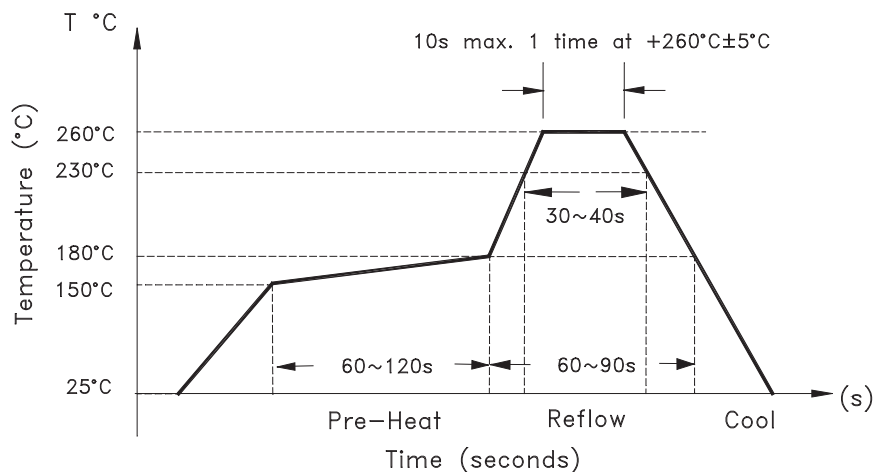

ABRACON IS  
ISO9001:2008  
CERTIFIED



**ABRACON**  
CORPORATION

Visit [www.abracon.com](http://www.abracon.com) for Terms & Conditions of Sale **Revised: 04.27.12**  
30332 Esperanza, Rancho Santa Margarita, California 92688  
tel 949-546-8000 | fax 949-546-8001 | [www.abracon.com](http://www.abracon.com)

# Programmable - High Performance SMD XO & VCXO

ASG-P Series



RoHS  
Compliant



7.0 x 5.0 x 1.9mm

## TAPE & REEL:

T= Tape and reel (2,000pcs/reel)

### TAPE DETAIL (SCALE 2 : 1)

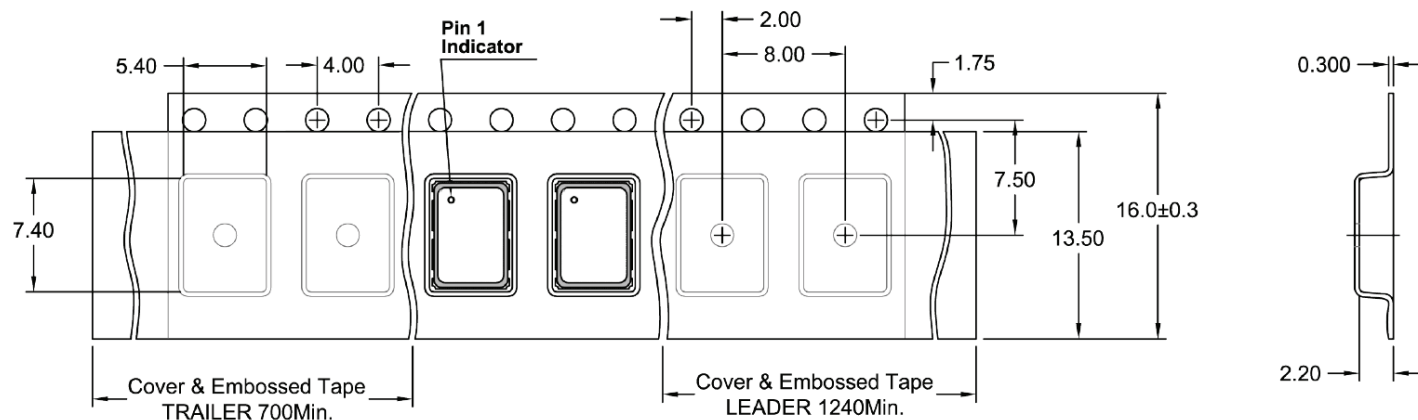

### REEL DETAIL (SCALE 1 : 2.5)

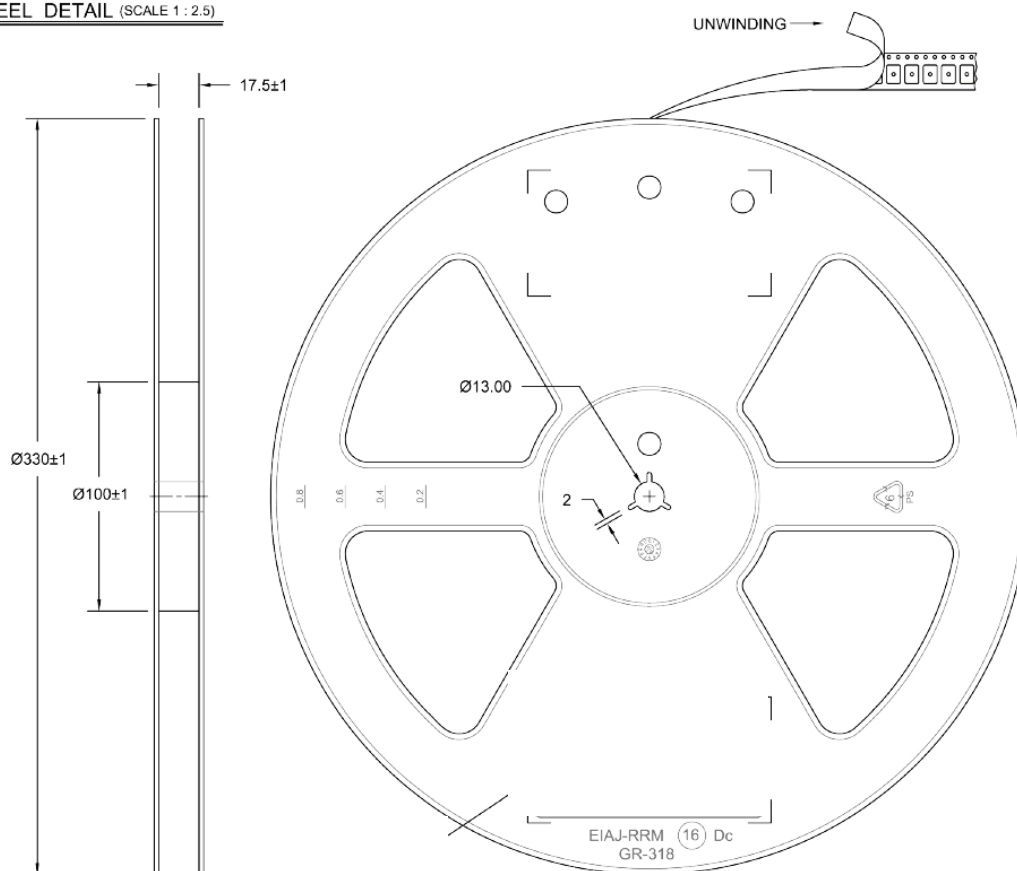

**ATTENTION:** Abracon Corporation's products are COTS – Commercial-Off-The-Shelf products; suitable for Commercial, Industrial and, where designated, Automotive Applications. Abracon's products are not specifically designed for Military, Aviation, Aerospace, Life-dependant Medical applications or any application requiring high reliability where component failure could result in loss of life and/or property. For applications requiring high reliability and/or presenting an extreme operating environment, written consent and authorization from Abracon Corporation is required. Please contact Abracon Corporation for more information.

ABRACON IS  
ISO9001:2008  
CERTIFIED

Visit [www.abracon.com](http://www.abracon.com) for Terms & Conditions of Sale **Revised: 04.27.12**  
30332 Esperanza, Rancho Santa Margarita, California 92688  
tel 949-546-8000 | fax 949-546-8001 | [www.abracon.com](http://www.abracon.com)

## X-ON Electronics

Largest Supplier of Electrical and Electronic Components

*Click to view similar products for [VCXO Oscillators](#) category:*

*Click to view products by [ABRACON](#) manufacturer:*

Other Similar products are found below :

[KD-VA9501](#) [ASG-P-V-A-491.520MHz](#) [SIT3808AI-CF-33EM-50.000000X](#) [EQVA23C1C1H-50.000M](#) [603281](#) [YNETHE125](#) [FRSONT019](#)  
[SiT3701AC-43-33C-10.00000X](#) [SiT3808AI-2F-25NM-4.915200X](#) [315LB3I1250T](#) [VG-4231CE](#) [27.0000M-PSCM3](#) [CVPD-922X-100.000](#)  
[CVSS-945-125.000](#) [ASVV-4.096 MHz-L50-N152-T](#) [565DFA45M1500ABG](#) [565CFA45M1584ABG](#) [569DABA001908BBG](#)  
[569BAAA001478ABG](#) [565AAA1000M00BBG](#) [565CAA11M0592BBG](#) [565BAA100M000ABG](#) [CVHD-950-122.880](#) [CVHD-950-70.000](#)  
[CVHD-950-80.000](#) [CVHD-950X-100.000](#) [CVHD-950X-122.88](#) [CVHD950X-54.000](#) [CVPD-920-100.000](#) [515CAA000256AAG](#)  
[550AE100M000DG](#) [MK3722GLFTR](#) [CVHD-950X-50.000](#) [ABLJO-V-122.880MHZ-T2](#) [PL500-37TI](#) [KV7050B27.0000C3GD00](#)  
[VCS25AXT-270](#) [27.000MHZ](#) [357LB3I032M7680](#) [357LB3I040M0000](#) [KV7050B25.0000C3GD00](#) [357LB3I016M3840](#) [CVHD-950-76.800](#)  
[CVSS-945-50.000](#) [KV7050B40.0000C3GD00](#) [EV32C6A3A1-24.576M-TR](#) [LFVCXO067516Bulk](#) [ECXV-L37C2N-148.500](#)  
[LFVCXO067414Bulk](#) [LFVCXO067507Bulk](#) [VS-501-0074-1000M0](#) [LFVCXO067538Bulk](#)