

SMD SHIELDED POWER INDUCTOR

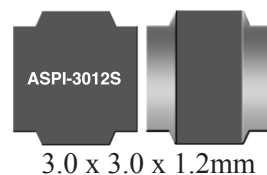

ASPI-3012S



RoHS/RoHS II Compliant

3.0 x 3.0 x 1.2mm

FEATURES:

- Shielded magnetics, low radiation
- Large Terminal surface for good PCB bonding
- Low DCR, High Energy storage, suitable for large currents
- Ideal for a variety of DC-DC converter inductor applications

APPLICATIONS:

- Portable communication equipment
- OA equipment
- LCD, DVD, modem, set-top box
- DC/DC converters

ELECTRICAL SPECIFICATIONS:

Abrakon P/N:	ASPI-3012S Series
Operating Temperature :	-40°C to +125°C
Storage Temperature :	-10°C to +40°C and 70% R.H.

Part Number ASPI-3012S- Inductance Code	Inductance	L Tolerance	DC Resistance (±30%)	Saturation Current	Temperature Rise Current	Min. Self resonant frequency	Inductance Code
Units	μH	—	Ω	A	A	MHz	
Symbol	L	N, M	DCR	Isat	Irms	SRF	
ASPI-3012S-R82	0.82	N	0.030	2.05	2.47	180	R82
ASPI-3012S-1R0	1.0	N	0.040	1.87	2.20	120	1R0
ASPI-3012S-1R2	1.2	N	0.045	2.22	2.01	120	1R2
ASPI-3012S-1R5	1.5	N	0.045	1.62	2.01	110	1R5
ASPI-3012S-1R8	1.8	N	0.063	1.30	1.65	90	1R8
ASPI-3012S-2R2	2.2	N	0.075	1.20	1.55	84	2R2
ASPI-3012S-2R4	2.4	N	0.068	1.15	1.60	100	2R4
ASPI-3012S-2R7	2.7	M,N	0.085	1.14	1.48	65	2R7
ASPI-3012S-3R3	3.3	M,N	0.100	1.05	1.36	64	3R3
ASPI-3012S-3R9	3.9	M,N	0.145	1.00	1.24	61	3R9
ASPI-3012S-4R7	4.7	M,N	0.120	0.90	1.24	61	4R7
ASPI-3012S-6R8	6.8	M,N	0.190	0.75	0.98	61	6R8
ASPI-3012S-100	10	M,N	0.265	0.60	0.83	42	100
ASPI-3012S-120	12	M,N	0.345	0.48	0.73	32	120
ASPI-3012S-150	15	M,N	0.360	0.45	0.71	27	150
ASPI-3012S-180	18	M,N	0.545	0.43	0.58	25	180
ASPI-3012S-220	22	M,N	0.645	0.42	0.53	23	220
ASPI-3012S-270	27	M,N	0.870	0.35	0.47	21	270
ASPI-3012S-330	33	M,N	0.875	0.36	0.46	18	330
ASPI-3012S-360	36	M,N	0.950	0.34	0.44	18	360
ASPI-3012S-390	39	M,N	1.330	0.30	0.37	18	390
ASPI-3012S-470	47	M,N	1.450	0.27	0.35	14	470
ASPI-3012S-680	68	M,N	1.670	0.24	0.33	12	680
ASPI-3012S-820	82	M,N	2.540	0.17	0.27	12	820
ASPI-3012S-101	100	M,N	2.860	0.21	0.25	12	101

Test Conditions:

- Ambient Temperature: 20± 15°C
- Relative Humidity: 65%±20%
- Air Pressure: 86KPa to 106KPa

Inductance (L): ZM2355 LCR meter or equivalent, 100kHz, 1V_{rms}

Direct Current Resistance (DCR): HIOKI 3540 or equivalent

Saturation Current (Isat): E3260B meter or equivalent

Isat: Based on inductance change (ΔL/Lo :Δ -30%)

Temperature rise current (Irms): Electric Power, Electric current meter, Thermometer

Irms: Based on temperature rise (ΔT : 40 °C TYP.)

ABRACON IS
ISO 9001:2008
CERTIFIED



ABRACON
CORPORATION

Visit www.abracon.com for Terms & Conditions of Sale **Revised: 08.14.13**
30332 Esperanza, Rancho Santa Margarita, California 9268
tel 949-546-8000 | fax 949-546-8001 | www.abracon.com

SMD SHIELDED POWER INDUCTOR

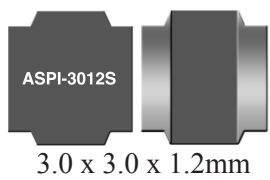

ASPI-3012S

3.0 x 3.0 x 1.2mm

ASPI-3012S



RoHS/RoHS II Compliant

ELECTRICAL SPECIFICATIONS:

Temperature vs. DC Current Characteristics

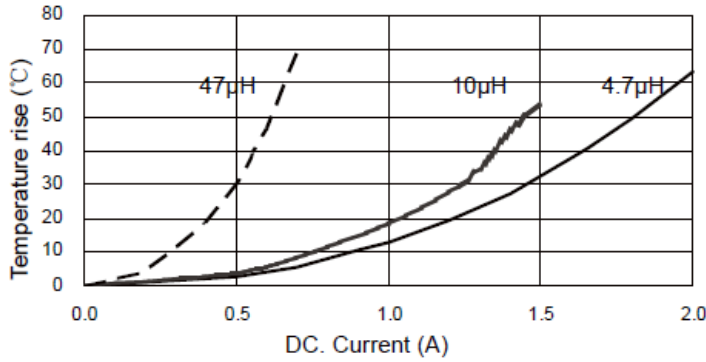

Inductance vs. DC Current Characteristics

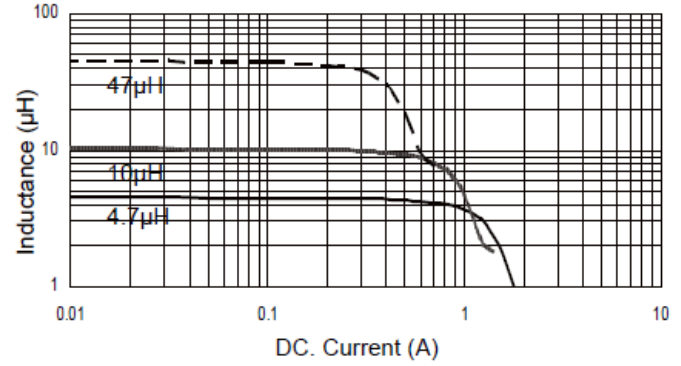

Inductance VS Frequency

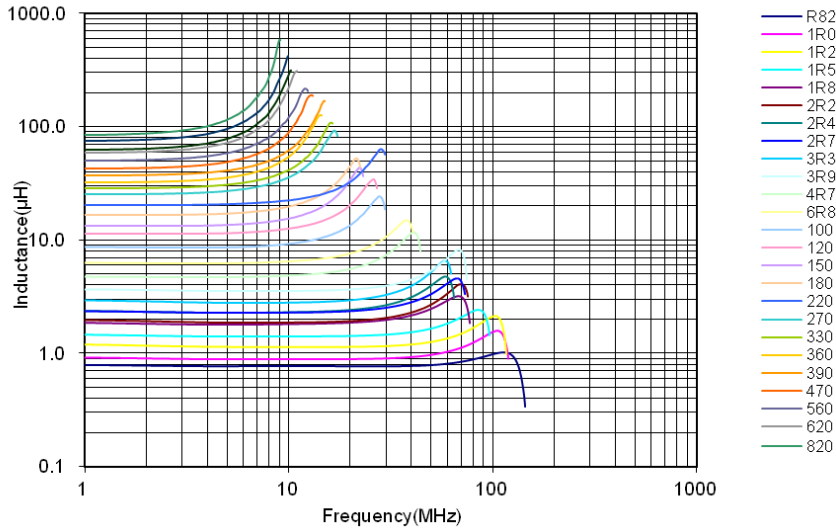

OPTIONS AND PART IDENTIFICATION

ASPI-3012S - -

Inductance Code
Please refer to the table above

Tolerance
M: ±20% *
N: ±30% *

Packaging
T: Tape and Reel
(2kpcs / reel)

*M for 2.7µH~100µH
*N for 0.82µH~100µH

ABRACON IS
ISO 9001:2008
CERTIFIED



ABRACON
CORPORATION

Visit www.abracon.com for Terms & Conditions of Sale **Revised: 08.14.13**
30332 Esperanza, Rancho Santa Margarita, California 9268
tel 949-546-8000 | fax 949-546-8001 | www.abracon.com

SMD SHIELDED POWER INDUCTOR

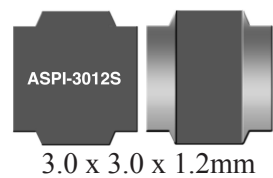

ASPI-3012S



RoHS/RoHS II Compliant

3.0 x 3.0 x 1.2mm

OUTLINE DIMENSIONS:

Recommended Land Pattern

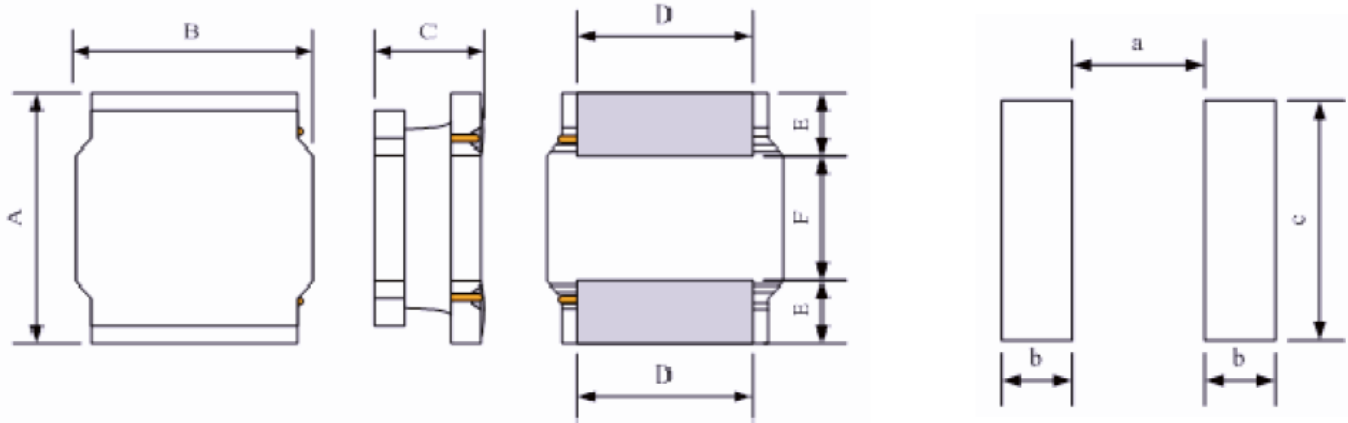

A	B	C Max.	D	E	F	a Typ.	b Typ.	c Typ.
3.0±0.2	3.0±0.2	1.2Max.	2.5±0.2	0.75±0.2	1.5±0.2	1.5Typ.	0.8Typ.	2.7Typ.

Dimensions: mm

Materials

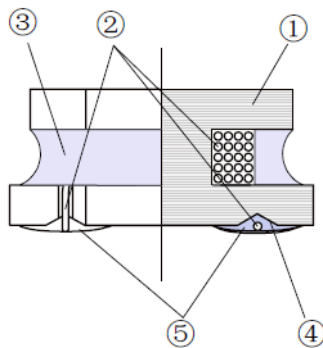

No	Components	Material
1	Ferrite Core	Ni-Zn Ferrite
2	Wire	Polyurethane System enameled copper wire
3	Magnetic Glue	Epoxy resin and magnetic powder
4	Plating Electrodes	Plating: Ag/Ni/Sn
5	Outer Electrodes	Top surface solder coating: Sn96.5%/Ag3%/Cu0.5%

REFLOW PROFILE:

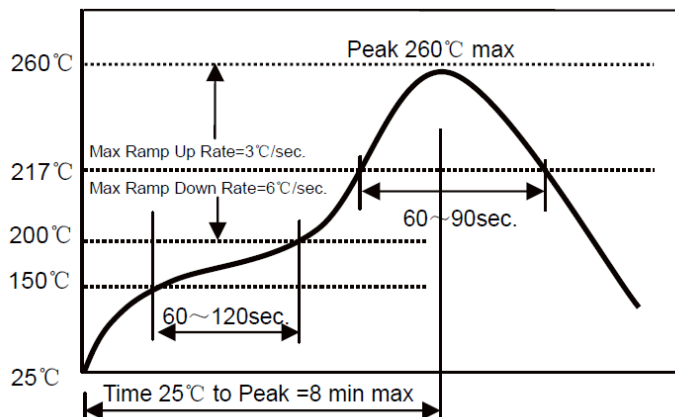

- Δ Preheat condition: 150 ~200°C/60~120sec.
- Δ Allowed time above 217°C: 60~90sec.
- Δ Max temp: 260°C
- Δ Max time at max temp: 5sec.
- Δ Solder paste: Sn/3.0Ag/0.5Cu
- Δ Allowed Reflow time: 2x max



SMD SHIELDED POWER INDUCTOR

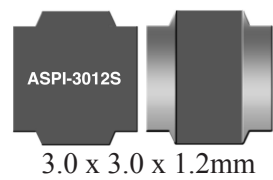

ASPI-3012S



RoHS/RoHS II Compliant

3.0 x 3.0 x 1.2mm

TAPE & REEL:

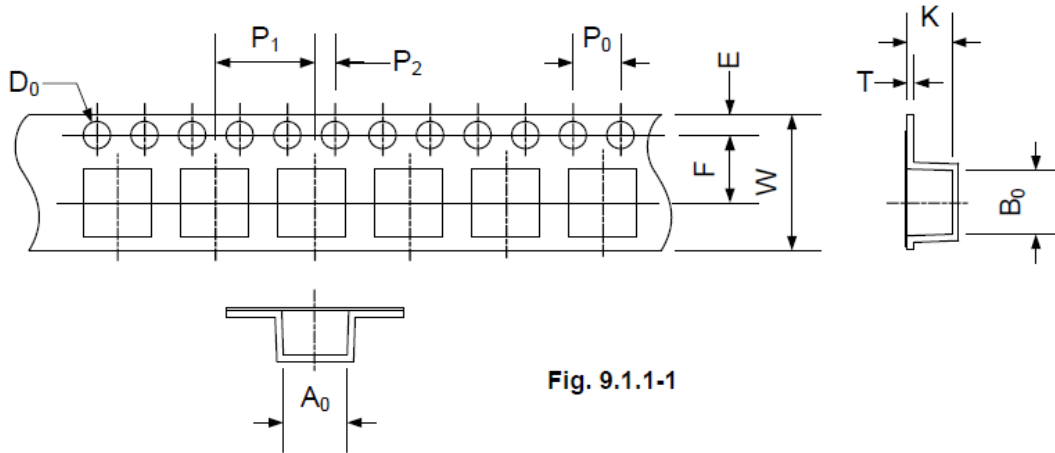
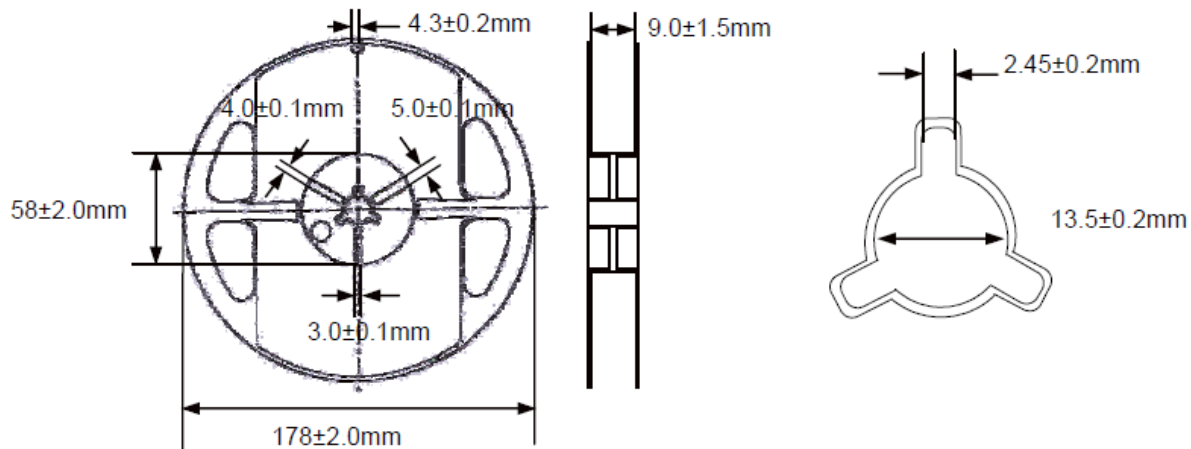

Fig. 9.1.1-1

A0	B0	W	E	F	P0	P1	P2	D0	T	K
3.3±0.1	3.3±0.1	8.0±0.3	1.75±0.1	3.5±0.05	4.0±0.1	4.0±0.1	2.0±0.1	1.5+0.1/-0.0	0.25±0.03	1.6±0.1



Storage Conditions

- To maintain the solderability of terminal electrodes and to keep the packing material in good condition, temperature and humidity in the storage area should be controlled.
- Recommended conditions: -10°C ~ 40 °C, 70% RH (Max.)
- Even under ideal storage conditions, solderability of products electrodes may decrease as time passes. For this reason, product should be used with one year from the time of delivery.
- In case of storage over 6 months, solderability shall be checked before actual usage.

Dimension: mm

ATTENTION: Abracon Corporation's products are COTS – Commercial-Off-The-Shelf products; suitable for Commercial, Industrial and, where designated, Automotive Applications. Abracon's products are not specifically designed for Military, Aviation, Aerospace, Life-dependant Medical applications or any application requiring high reliability where component failure could result in loss of life and/or property. For applications requiring high reliability and/or presenting an extreme operating environment, written consent and authorization from Abracon Corporation is required. Please contact Abracon Corporation for more information.

ABRACON IS
ISO 9001:2008
CERTIFIED



Visit www.abracon.com for Terms & Conditions of Sale **Revised: 08.14.13**
30332 Esperanza, Rancho Santa Margarita, California 9268
tel 949-546-8000 | fax 949-546-8001 | www.abracon.com

X-ON Electronics

Largest Supplier of Electrical and Electronic Components

Click to view similar products for [Fixed Inductors](#) category:

Click to view products by [Abracon](#) manufacturer:

Other Similar products are found below :

[CR32NP-100KC](#) [CR54NP-470LC](#) [70F224AI](#) [MGDQ4-00004-P](#) [MHQ1005P10NJ](#) [MHQ1005P1N0S](#) [MHQ1005P2N4S](#) [MHQ1005P3N6S](#)
[MHQ1005P5N1S](#) [MHQ1005P8N2J](#) [PE-53601NL](#) [PE-53602NL](#) [PG0936.113NLT](#) [9220-20](#) [9310-16](#) [PM06-2N7](#) [PM06-39NJ](#) [A01TK](#)
[1206CS-471XJ](#) [HC8-1R2-R](#) [HCF1305-3R3-R](#) [1206CS-151XG](#) [RCH664NP-140L](#) [RCP1317NP-391L](#) [RCR110DNP-331L](#) [DH2280-4R7M](#)
[DS1608C-106](#) [B10TJ](#) [B82498B3101J000](#) [ELJ-RE27NJF2](#) [1812CS-153XJ](#) [1812CS-183XJ](#) [1812CS-223XJ](#) [1812LS-104XJ](#) [1812LS-105XJ](#)
[1812LS-124XJ](#) [1812LS-154XJ](#) [1812LS-223XJ](#) [1812LS-224XJ](#) [1812LS-563XJ](#) [1812LS-683XJ](#) [1812LS-824XJ](#) [NIN-FA4R7JTR220F](#) [NIN-](#)
[FB101JTR110F](#) [NIN-FB471JTR62F](#) [NIN-FC1R5JTR220F](#) [NIN-HCR15JTRF](#) [NIN-HCR33JTRF](#) [NIN-HDR22JTRF](#) [NIN-HDR82JTRF](#)