

REGULATORY COMPLIANCE

| | | | | |
|--|--|--|--|---|
|  <p>Lead Free COMPLIANT</p> |  <p>EU RoHS 2011/65 + 2015/863 COMPLIANT</p> |  <p>China RoHS COMPLIANT</p> |  <p>REACH SVHC COMPLIANT</p> |  <p>DRC CONFLICT FREE</p> |
|--|--|--|--|---|

ITEM DESCRIPTION

MEMS Clock Oscillators LVCMOS (CMOS) 2.5Vdc 4 Pad 5.0mm x 7.0mm Plastic Surface Mount (SMD)

ELECTRICAL SPECIFICATIONS

| | |
|--|--|
| Nominal Frequency | 1MHz to 125MHz |
| Frequency Tolerance/Stability | Inclusive of all conditions: Calibration Tolerance at 25°C, Frequency Stability over the Operating Temperature Range, Supply Voltage Change, Output Load Change, First Year Aging at 25°C, 260°C Reflow, Shock, and Vibration ±100ppm Maximum over 0°C to +70°C ±50ppm Maximum over 0°C to +70°C ±25ppm Maximum over 0°C to +70°C ±100ppm Maximum over -20°C to +70°C ±50ppm Maximum over -20°C to +70°C ±25ppm Maximum over -20°C to +70°C ±100ppm Maximum over -40°C to +85°C ±50ppm Maximum over -40°C to +85°C ±25ppm Maximum over -40°C to +85°C ±20ppm Maximum over 0°C to +70°C ±20ppm Maximum over -20°C to +70°C ±20ppm Maximum over -40°C to +85°C |
| Aging at 25°C | ±1ppm Maximum First Year |
| Supply Voltage | 2.5Vdc ±5% |
| Input Current | No Load 5mA Maximum over Nominal Frequency of 1MHz to 20MHz 6mA Maximum over Nominal Frequency of 20.000001MHz to 50MHz 7mA Maximum over Nominal Frequency of 50.000001MHz to 80MHz 8mA Maximum over Nominal Frequency of 80.000001MHz to 125MHz |
| Output Voltage Logic High (V_{oh}) | I _{OH} =-3mA 90% of V _{dd} Minimum |
| Output Voltage Logic Low (V_{ol}) | I _{OL} =+3mA 10% of V _{dd} Maximum |
| Rise/Fall Time | Measured from 20% to 80% of waveform 1.2nSec Typical, 3n Sec Maximum |
| Duty Cycle | Measured at 50% of waveform 50 ±10(%) 50 ±5(%) |
| Load Drive Capability | 15pF Maximum |
| Output Logic Type | CMOS |
| Output Control Function | Tri-State (Disabled Output: High Impedance) Power Down (Disabled Output: Logic Low) |
| Output Control Input Voltage | 70% of V _{dd} Minimum or No Connect to Enable Output, 30% of V _{dd} Maximum to Disable Output |
| Power Down Output Enable Time | 5mSec Maximum |
| Tri-State Output Enable Time | 150nSec Maximum |
| Power Down Output Disable Time | 150nSec Maximum |
| Tri-State Output Disable Time | 150nSec Maximum |
| Period Jitter (RMS) | 2psec Typical, 4pSec Maximum |
| RMS Phase Jitter (F_j = 900kHz to 7.5MHz; Random) | 0.5pSec Typical, 1pSec Maximum |
| RMS Phase Jitter (F_j = 12kHz to 20MHz; Random) | 1.5pSec Typical, 3pSec Maximum |

| | |
|---------------------------|---|
| Standby Current | 10µA Maximum (Disabled Output: Logic Low) |
| Start Up Time | 5mSec Maximum |
| Storage Temperature Range | -65°C to +150°C |

PART NUMBERING GUIDE

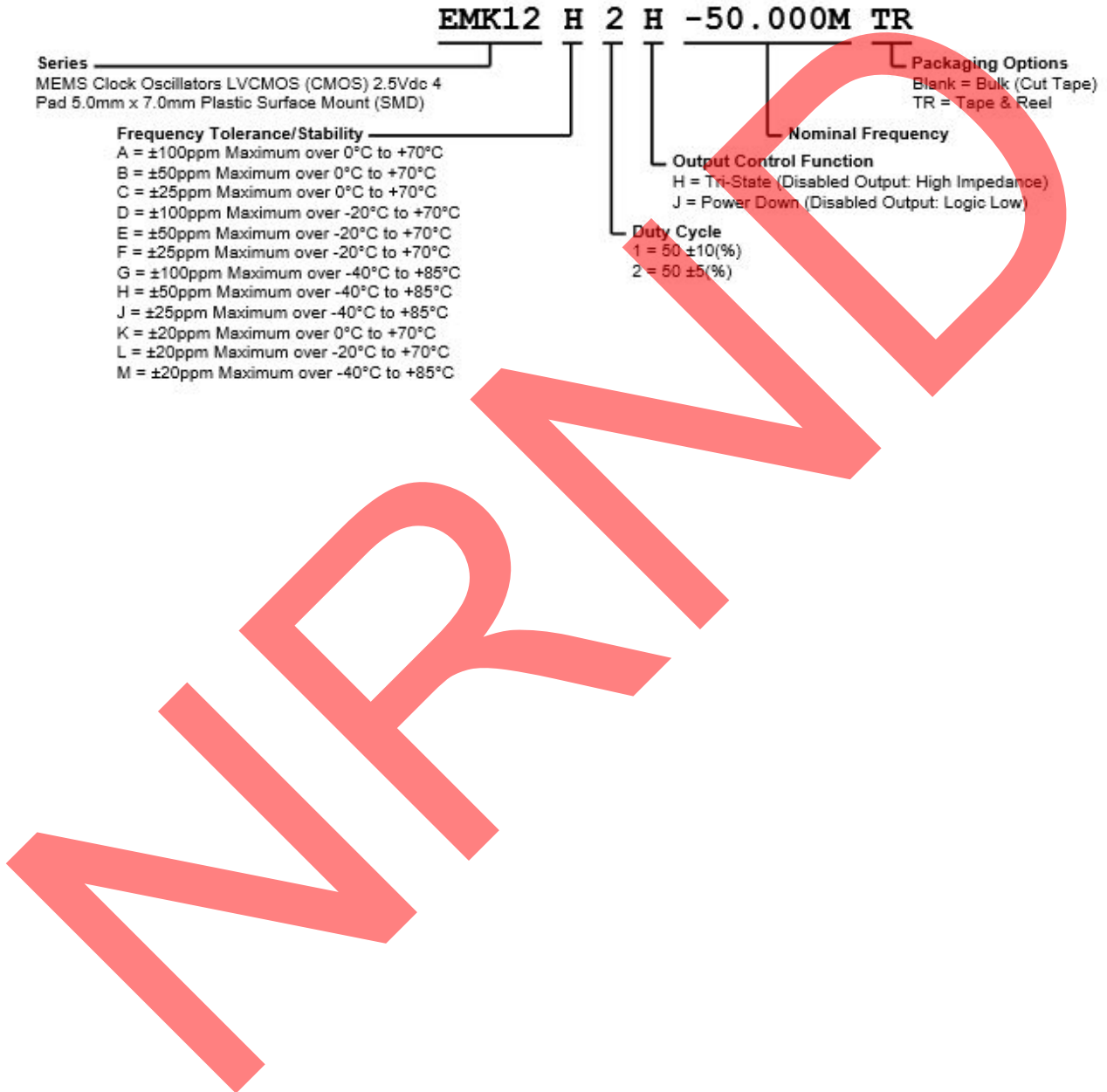

MECHANICAL DIMENSIONS

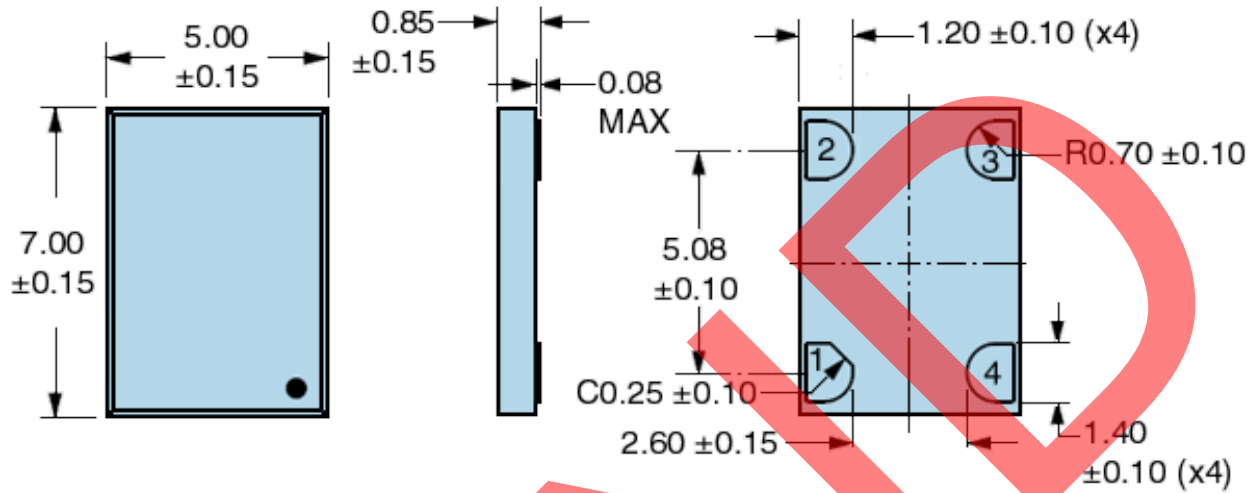

SUGGESTED SOLDER PAD LAYOUT

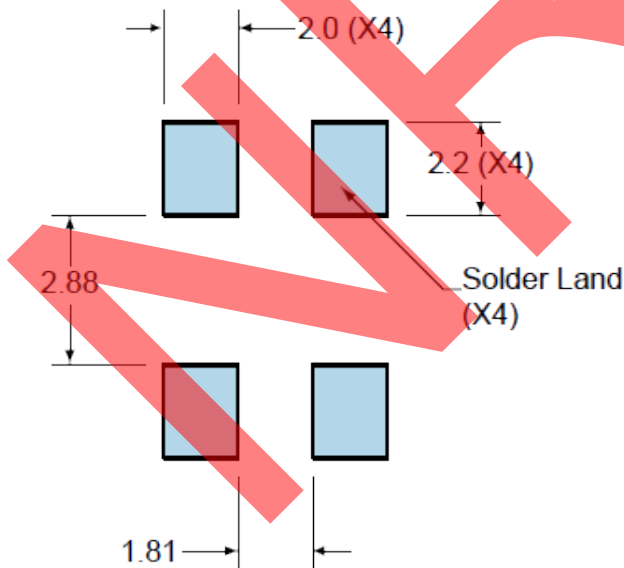

| PIN | CONNECTION |
|-----|-------------------------|
| 1 | Power Down or Tri-State |
| 2 | Ground |
| 3 | Output |
| 4 | Supply Voltage |

All Tolerances are ±0.1

All Dimensions in Millimeters

OUTPUT WAVEFORM & TIMING DIAGRAM

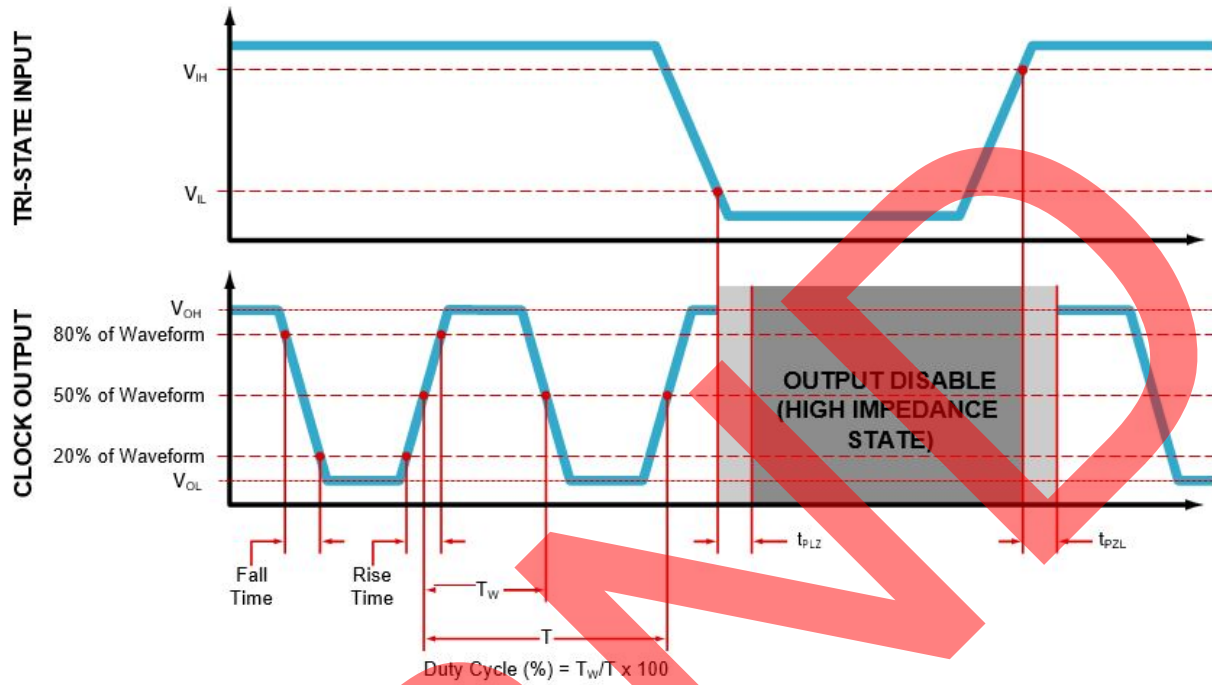

TEST CIRCUIT FOR CMOS OUTPUT

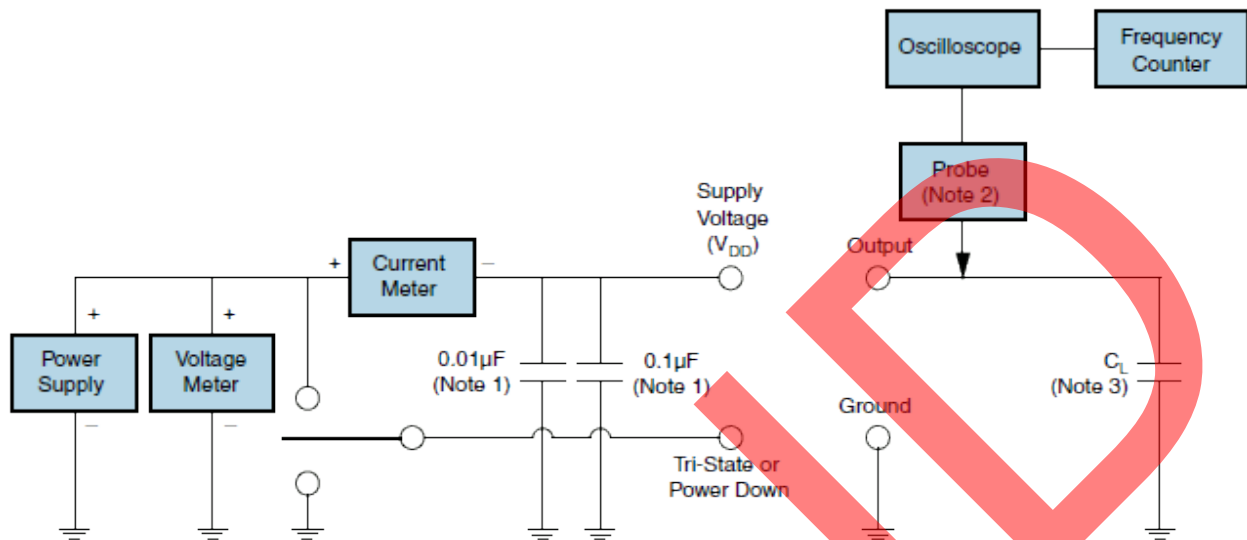

Note 1: An external $0.01\mu\text{F}$ ceramic bypass capacitor in parallel with a $0.1\mu\text{F}$ high frequency ceramic bypass capacitor close (less than 2mm) to the package ground and supply voltage pin is required.

Note 2: A low input capacitance ($<12\text{pF}$), 10X Attenuation Factor, High Impedance ($>10\text{Mohms}$), and High bandwidth ($>300\text{MHz}$) Passive probe is recommended.

Note 3: Capacitance value C_L includes sum of all probe and fixture capacitance. See applicable specification sheet for Load Drive Capability.

TAPE & REEL DIMENSIONS

Quantity per Reel: 1,000 Units

All Dimensions in Millimeters

Compliant to EIA-481

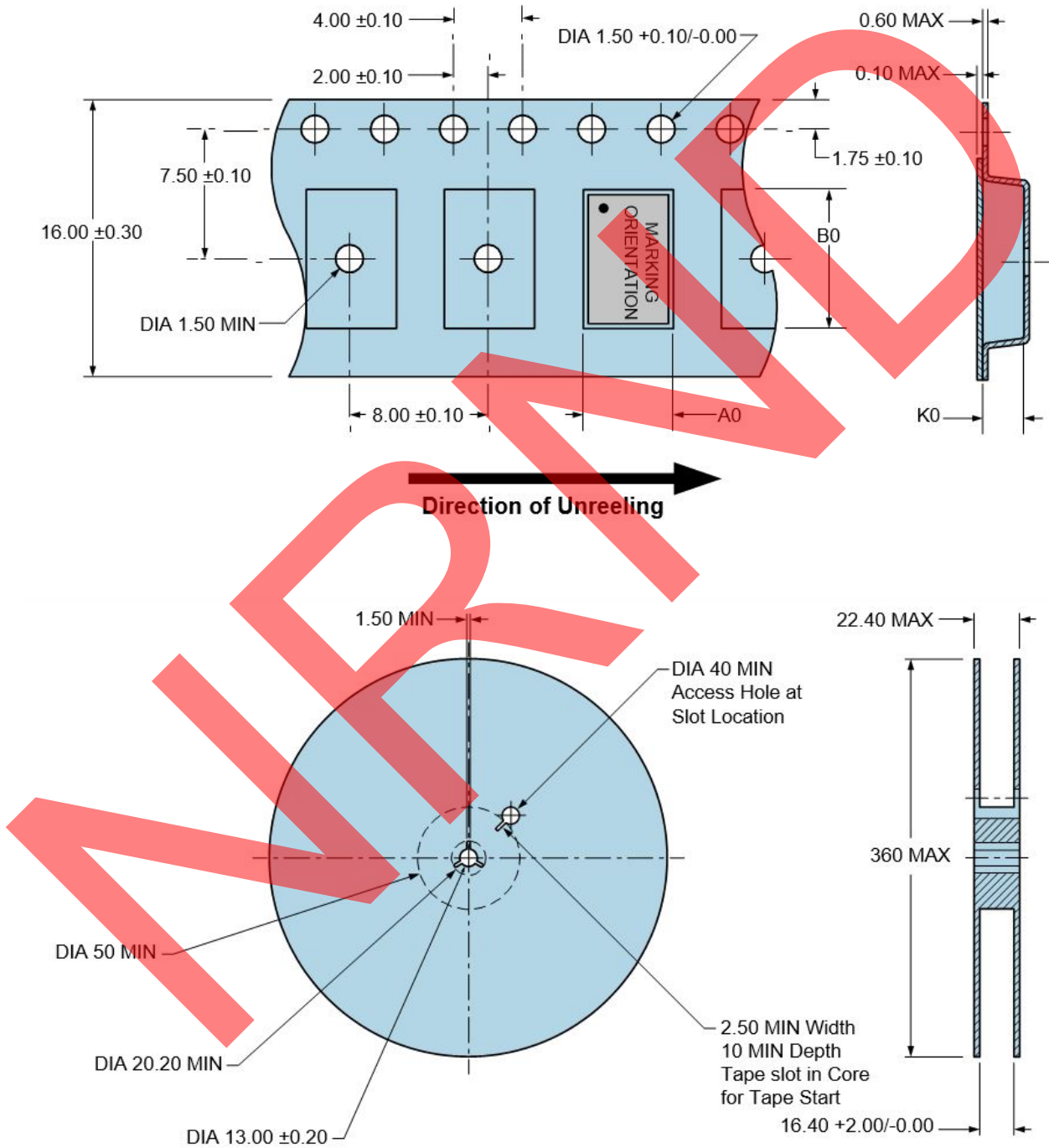

RECOMMENDED SOLDER REFLOW METHOD

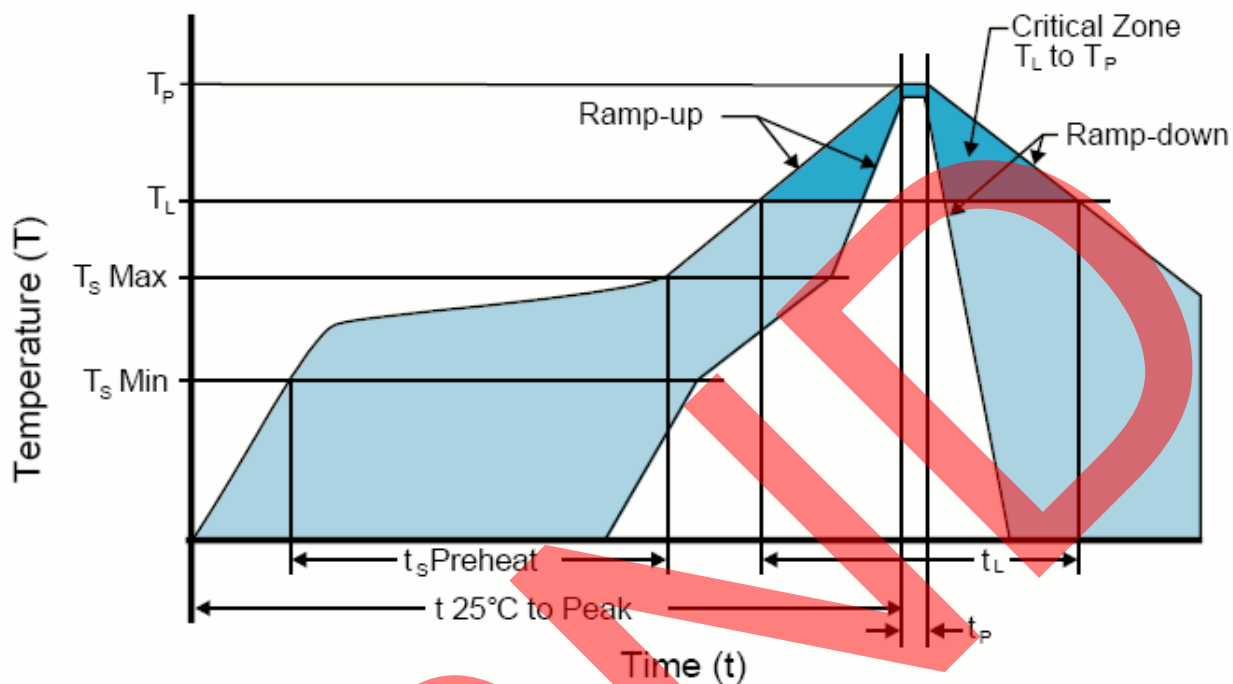

HIGH TEMPERATURE INFRARED/CONVECTION

| | |
|--|---|
| $T_s \text{ MAX to } T_L$ (Ramp-up Rate) | 3°C/Second Maximum |
| Preheat | |
| - Temperature Minimum ($T_s \text{ MIN}$) | 150°C |
| - Temperature Typical ($T_s \text{ TYP}$) | 175°C |
| - Temperature Maximum ($T_s \text{ MAX}$) | 200°C |
| - Time (t_s) | 60 - 180 Seconds |
| Ramp-up Rate (T_L to T_P) | 3°C/Second Maximum |
| Time Maintained Above: | |
| - Temperature (T_L) | 217°C |
| - Time (t_L) | 60 - 150 Seconds |
| Peak Temperature (T_P) | 260°C Maximum for 10 Seconds Maximum |
| Target Peak Temperature ($T_P \text{ Target}$) | 250°C +0/-5°C |
| Time within 5°C of actual peak (t_p) | 20 - 40 Seconds |
| Ramp-down Rate | 6°C/Second Maximum |
| Time 25°C to Peak Temperature (t) | 8 Minutes Maximum |
| Moisture Sensitivity Level | Level 1 |
| Additional Notes | Temperatures shown are applied to body of device. |

High Temperature Manual Soldering

260°C Maximum for 5 Seconds Maximum, 2 times Maximum. (Temperatures shown are applied to body of device.)

RECOMMENDED SOLDER REFLOW METHOD

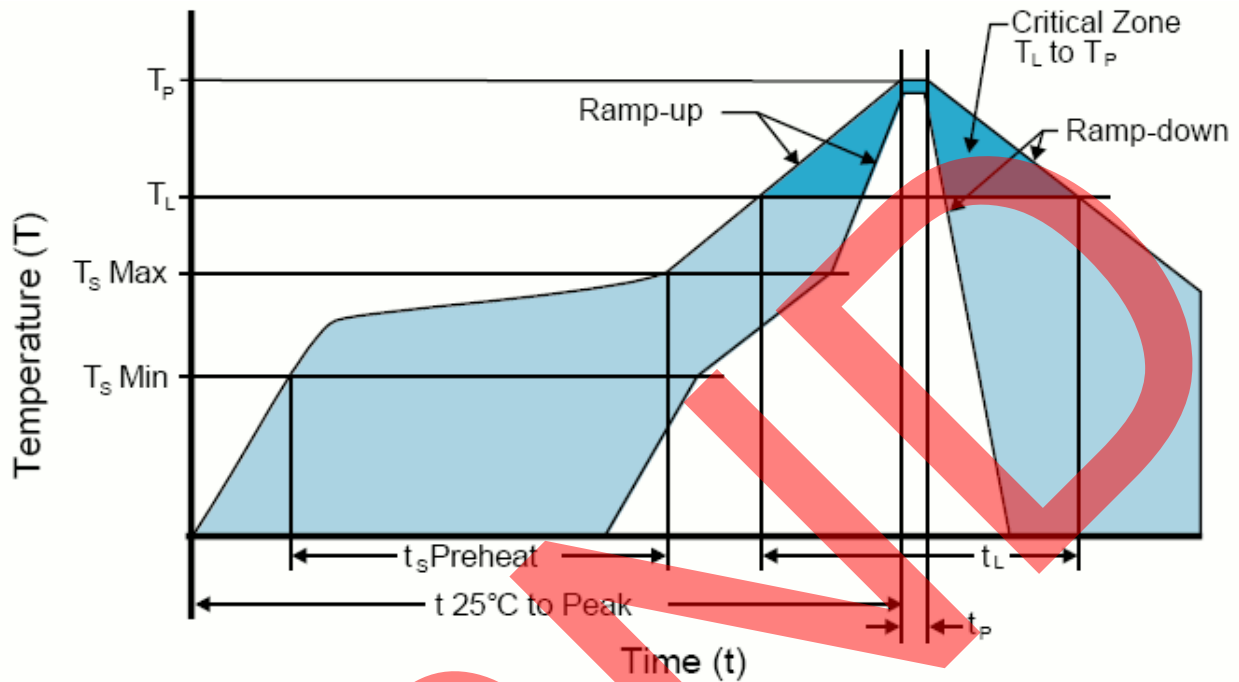

| LOW TEMPERATURE INFRARED/CONVECTION | |
|--|--|
| $T_s \text{ MAX to } T_L \text{ (Ramp-up Rate)}$ | 5°C/Second Maximum |
| Preheat | |
| - Temperature Minimum ($T_s \text{ MIN}$) | N/A |
| - Temperature Typical ($T_s \text{ TYP}$) | 150°C |
| - Temperature Maximum ($T_s \text{ MAX}$) | N/A |
| - Time (t_s) | 60 - 120 Seconds |
| Ramp-up Rate ($T_L \text{ to } T_P$) | 5°C/Second Maximum |
| Time Maintained Above: | |
| - Temperature (T_L) | 150°C |
| - Time (t_L) | 200 Seconds Maximum |
| Peak Temperature (T_P) | 240°C Maximum |
| Target Peak Temperature ($T_P \text{ Target}$) | 240°C Maximum 2 Times / 230°C Maximum 1 Time |
| Time within 5°C of actual peak (t_p) | 10 Seconds Maximum 2 Times / 80 Seconds Maximum 1 Time |
| Ramp-down Rate | 5°C/Second Maximum |
| Time 25°C to Peak Temperature (t) | N/A |
| Moisture Sensitivity Level | Level 1 |
| Additional Notes | Temperatures shown are applied to body of device. |

Low Temperature Manual Soldering

185°C Maximum for 10 Seconds Maximum, 2 times Maximum. (Temperatures shown are applied to body of device.)

X-ON Electronics

Largest Supplier of Electrical and Electronic Components

Click to view similar products for [Standard Clock Oscillators](#) category:

Click to view products by [Abracon](#) manufacturer:

Other Similar products are found below :

[601252](#) [F335-12](#) [F335-25](#) [F535L-33.333](#) [F535L-50](#) [ASV-20.000MHZ-LR-T](#) [ECS-2018-160-BN-TR](#) [MXO45HS-2C-66.6666MHZ](#)
[SiT8209AI-32-33E-125.000000](#) [SIT8918AA-11-33S-50.000000G](#) [SM4420TEV-40.0M-T1K](#) [F335-24](#) [F335-40](#) [F535L-10](#) [F535L-12](#) [F535L-](#)
[16](#) [F535L-24](#) [F535L-27](#) [F535L-48](#) [PE7744DW-100.0M](#) [CSX-750FCC14745600T](#) [ASF1-3.686MHZ-N-K-S](#) [XO57CTECNA3M6864](#) [ECS-](#)
[2100A-147.4](#) [601251](#) [EP16E7E2H26.000MTR](#) [SIT8918AA-11-33S-16.000000G](#) [XO3003](#) [9120AC-2D2-33E212.500000](#) [9102AI-](#)
[243N25E100.00000](#) [8208AC-82-18E-25.00000](#) [ASDK2-32.768KHZ-LR-T3](#) [8008AI-72-XXE-24.545454E](#) [8004AC-13-33E-133.33000X](#) [AS-](#)
[4.9152-16-SMD-TR](#) [ASFL1-48.000MHZ-LC-T](#) [SIT8920AM-31-33E-25.0000](#) [DSC1028DI2-019.2000](#) [9121AC-2C3-25E100.00000](#) [9102AI-](#)
[233N33E100.00000X](#) [9102AI-233N25E200.00000](#) [9102AI-232H25S125.00000](#) [9102AI-133N25E200.00000](#) [9102AC-283N25E200.00000](#)
[9001AC-33-33E1-30.000](#) [XLH536125.000JS4I](#) [3921AI-2CF-33NZ125.000000](#) [5730-1SF](#) [PXA000010](#) [SIT1602BC-83-33E-10.000000Y](#)