

## REGULATORY COMPLIANCE



## ITEM DESCRIPTION

MEMS Clock Oscillators LVCMOS (CMOS) 3.3Vdc 4 Pad 2.0mm x 2.5mm Plastic Surface Mount (SMD)

## ELECTRICAL SPECIFICATIONS

Nominal Frequency	1MHz to 125MHz
Frequency Tolerance/Stability	Inclusive of all conditions: Calibration Tolerance at 25°C, Frequency Stability over the Operating Temperature Range, Supply Voltage Change, and Output Load Change $\pm 100\text{ppm}$ Maximum over 0°C to +70°C $\pm 50\text{ppm}$ Maximum over 0°C to +70°C $\pm 25\text{ppm}$ Maximum over 0°C to +70°C $\pm 20\text{ppm}$ Maximum over 0°C to +70°C $\pm 100\text{ppm}$ Maximum over -20°C to +70°C $\pm 50\text{ppm}$ Maximum over -20°C to +70°C $\pm 25\text{ppm}$ Maximum over -20°C to +70°C $\pm 20\text{ppm}$ Maximum over -20°C to +70°C $\pm 100\text{ppm}$ Maximum over -40°C to +85°C $\pm 50\text{ppm}$ Maximum over -40°C to +85°C $\pm 25\text{ppm}$ Maximum over -40°C to +85°C $\pm 20\text{ppm}$ Maximum over -40°C to +85°C
Aging at 25°C	$\pm 1.5\text{ppm}$ Maximum First Year
Supply Voltage	3.3Vdc $\pm 10\%$
Input Current	No Load 5mA Maximum over Nominal Frequency of 1MHz to 20MHz 6mA Maximum over Nominal Frequency of 20.000001MHz to 50MHz 7mA Maximum over Nominal Frequency of 50.000001MHz to 80MHz 9mA Maximum over Nominal Frequency of 80.000001MHz to 125MHz
Output Voltage Logic High ( $V_{OH}$ )	$I_{OH} = -4\text{mA}$ 90% of Vdd Minimum
Output Voltage Logic Low ( $V_{OL}$ )	$I_{OL} = +4\text{mA}$ 10% of Vdd Maximum
Rise/Fall Time	Measured from 20% to 80% of waveform 1.2nSec Typical, 3nSec Maximum
Duty Cycle	Measured at 50% of waveform 50 $\pm 10\%$ 50 $\pm 5\%$
Load Drive Capability	15pF Maximum
Output Logic Type	CMOS
Output Control Function	Tri-State (Disabled Output: High Impedance) Power Down (Disabled Output: Logic Low)
Output Control Input Voltage Logic High ( $V_{IH}$ )	70% of Vdd Minimum or No Connect to Enable Output
Output Control Input Voltage Logic Low ( $V_{IL}$ )	30% of Vdd Maximum to Disable Output
Power Down Output Enable Time	5mSec Maximum
Tri-State Output Enable Time	150nSec Maximum
Power Down Output Disable Time	150nSec Maximum
Tri-State Output Disable Time	150nSec Maximum
Standby Current	10 $\mu\text{A}$ Maximum (Disabled Output: Logic Low)

# EMK43 Series



Period Jitter (RMS)	2pSec Typical, 4pSec Maximum
RMS Phase Jitter (Fj = 900kHz to 7.5MHz; Random)	0.5pSec Typical, 1pSec Maximum
RMS Phase Jitter (Fj = 12kHz to 20MHz; Random)	1.5pSec Typical, 3pSec Maximum
Start Up Time	5mSec Maximum
Storage Temperature Range	-65°C to +150°C

**MRND**

**PART NUMBERING GUIDE**

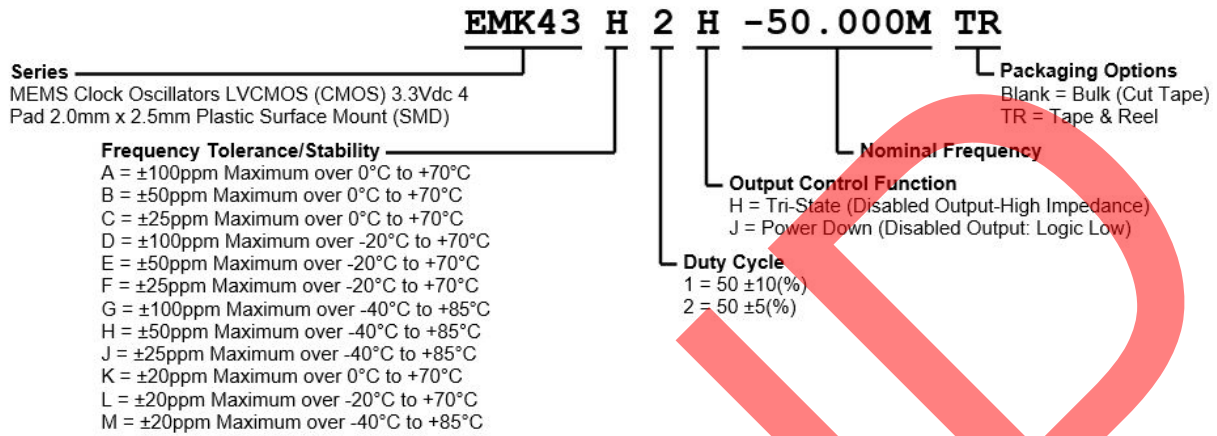

N  
R  
N  
O  
D  
E

**MECHANICAL DIMENSIONS**

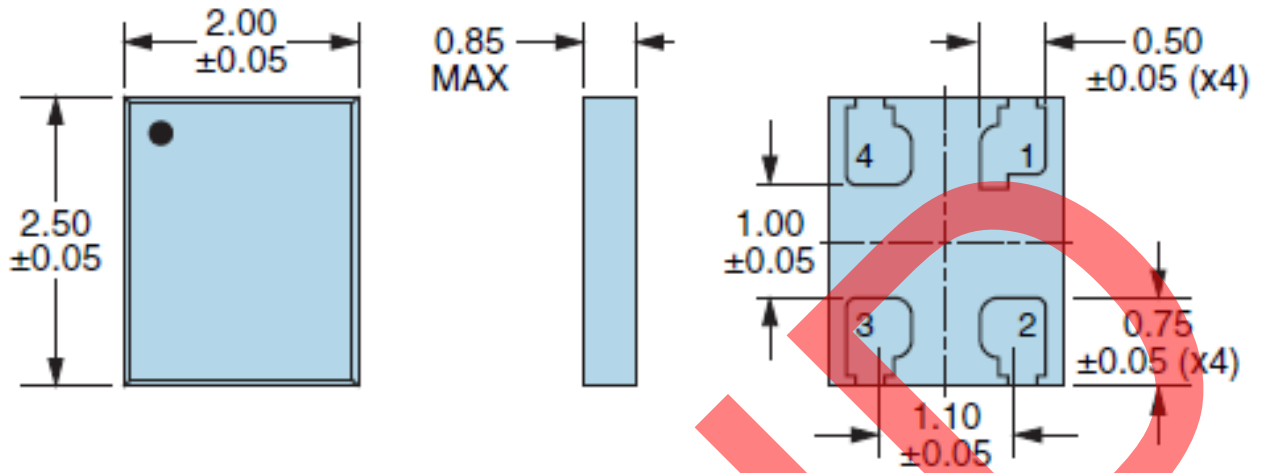

**SUGGESTED SOLDER PAD LAYOUT**

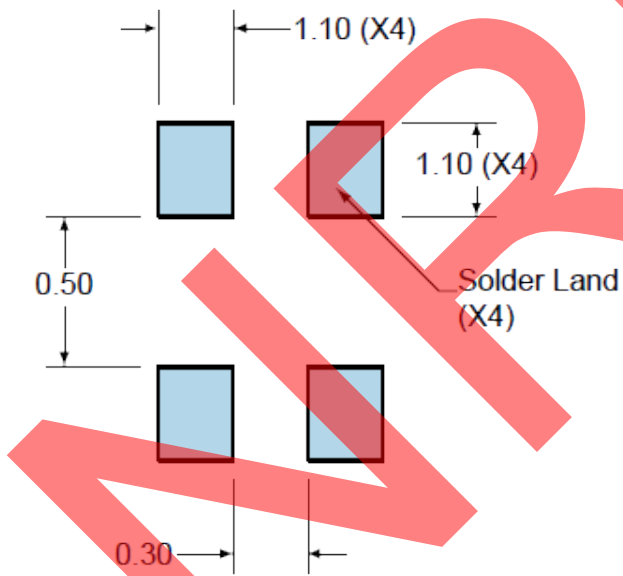

PIN	CONNECTION
1	Power Down Or Tri-State
2	Ground
3	Output
4	Supply Voltage

All Tolerances are  $\pm 0.1$

**All Dimensions in Millimeters**

OUTPUT WAVEFORM & TIMING DIAGRAM

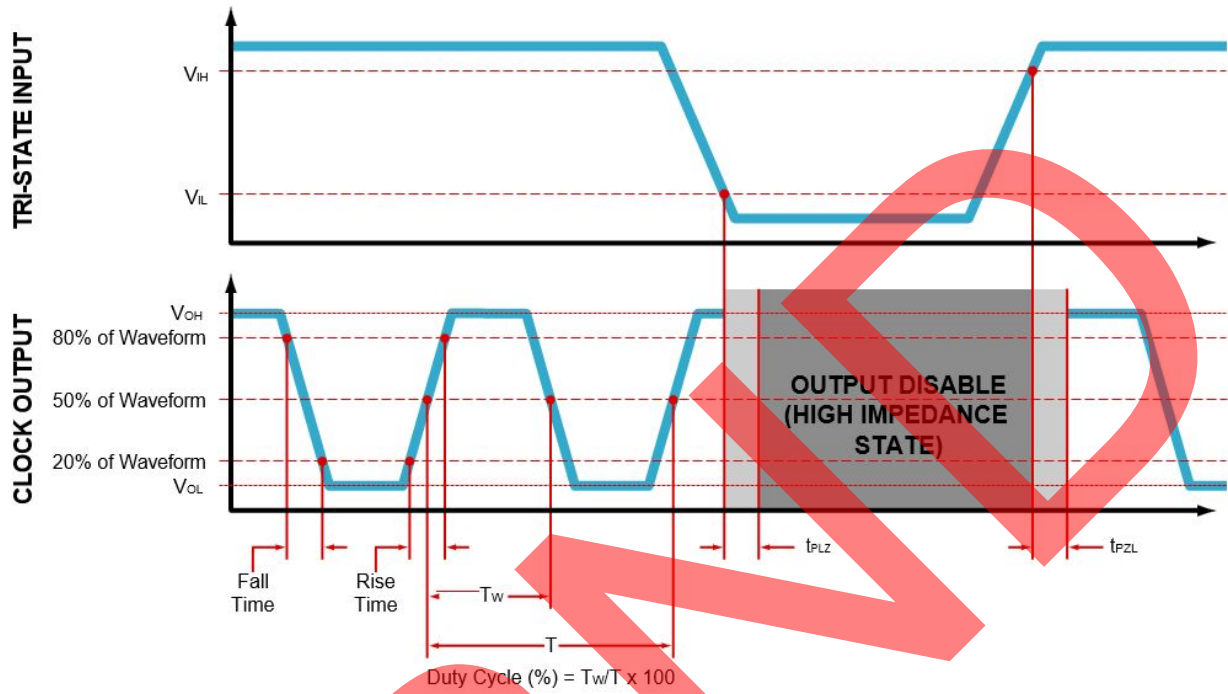

## TEST CIRCUIT FOR CMOS OUTPUT

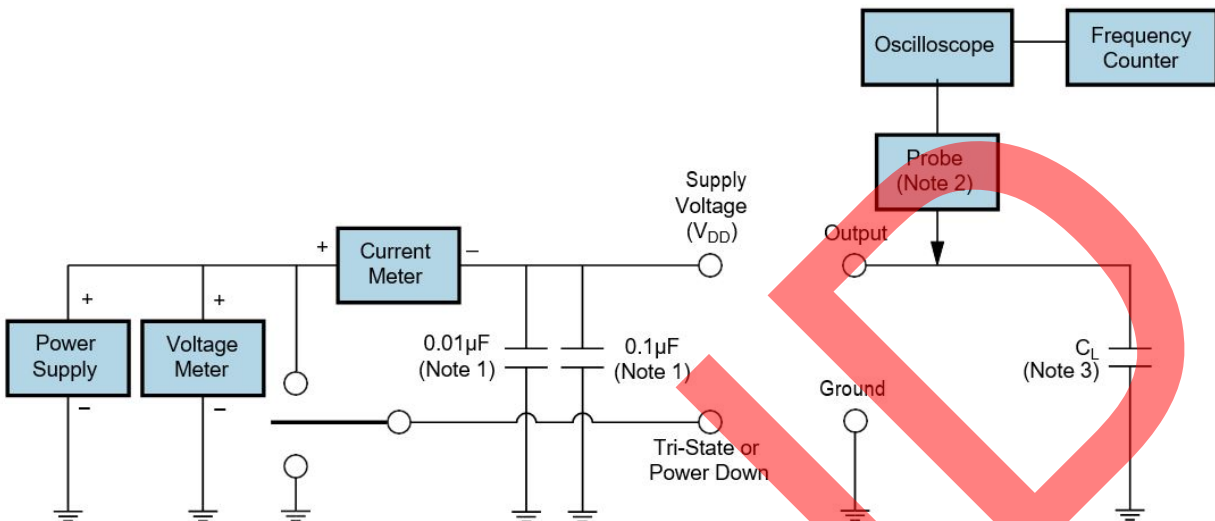

**Note 1:** An external  $0.01\mu\text{F}$  ceramic bypass capacitor in parallel with a  $0.1\mu\text{F}$  high frequency ceramic bypass capacitor close (less than 2mm) to the package ground and supply voltage pin is required.

**Note 2:** A low input capacitance ( $<12\text{pF}$ ), 10X Attenuation Factor, High Impedance ( $>10\text{Mohms}$ ), and High bandwidth ( $>300\text{MHz}$ ) Passive probe is recommended.

**Note 3:** Capacitance value  $C_L$  includes sum of all probe and fixture capacitance. See applicable specification sheet for 'Load Drive Capability'.

**TAPE & REEL DIMENSIONS**

Quantity per Reel: 1,000 Units

All Dimensions in Millimeters

Compliant to EIA-481

X = 8.00±0.30 or 12±0.30

Y = 3.50±0.05 or 5.5±0.05

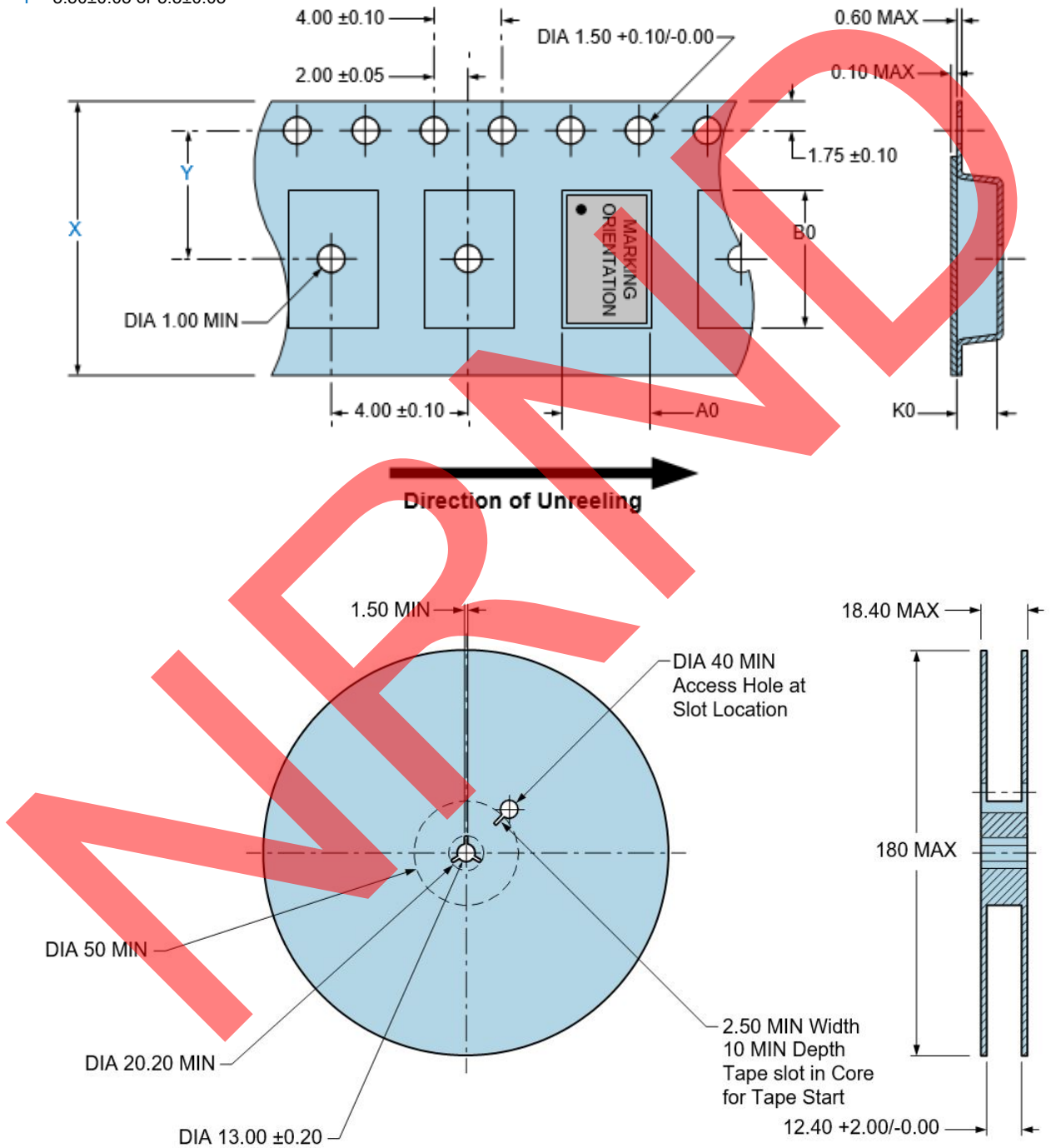

RECOMMENDED SOLDER REFLOW METHOD

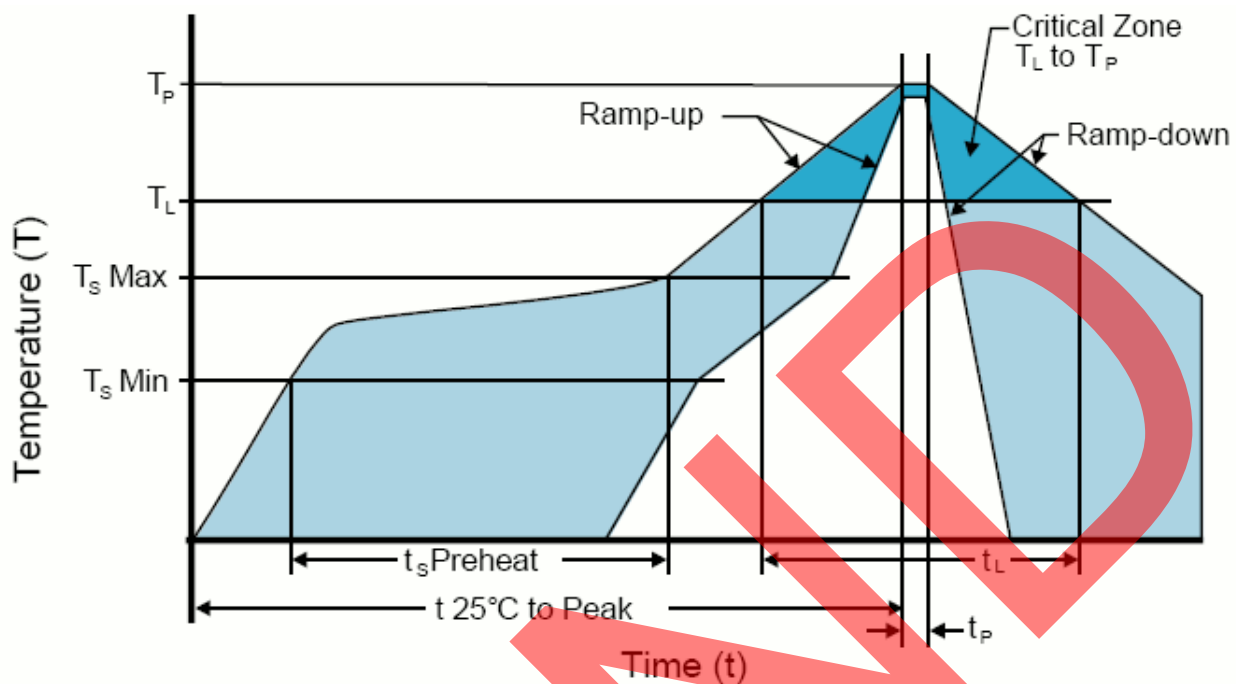

**HIGH TEMPERATURE INFRARED/CONVECTION**

<b><math>T_S \text{ MAX}</math> to <math>T_L</math> (Ramp-up Rate)</b>	3°C/Second Maximum
<b>Preheat</b>	
- Temperature Minimum ( $T_S \text{ MIN}$ )	150°C
- Temperature Typical ( $T_S \text{ TYP}$ )	175°C
- Temperature Maximum ( $T_S \text{ MAX}$ )	200°C
- Time ( $t_s \text{ MIN}$ )	60 - 180 Seconds
<b>Ramp-up Rate (<math>T_L</math> to <math>T_P</math>)</b>	3°C/Second Maximum
<b>Time Maintained Above:</b>	
- Temperature ( $T_L$ )	217°C
- Time ( $t_L$ )	60 - 150 Seconds
<b>Peak Temperature (<math>T_P</math>)</b>	260°C Maximum for 10 Seconds Maximum
<b>Target Peak Temperature (<math>T_P \text{ Target}</math>)</b>	250°C +0/-5°C
<b>Time within 5°C of actual peak (<math>t_P</math>)</b>	20 - 40 Seconds
<b>Ramp-down Rate</b>	6°C/Second Maximum
<b>Time 25°C to Peak Temperature (<math>t</math>)</b>	8 Minutes Maximum
<b>Moisture Sensitivity Level</b>	Level 1
<b>Additional Notes</b>	Temperatures shown are applied to body of device.

**High Temperature Manual Soldering**

260°C Maximum for 5 Seconds Maximum, 2 times Maximum. (Temperatures shown are applied to body of device.)



RECOMMENDED SOLDER REFLOW METHOD

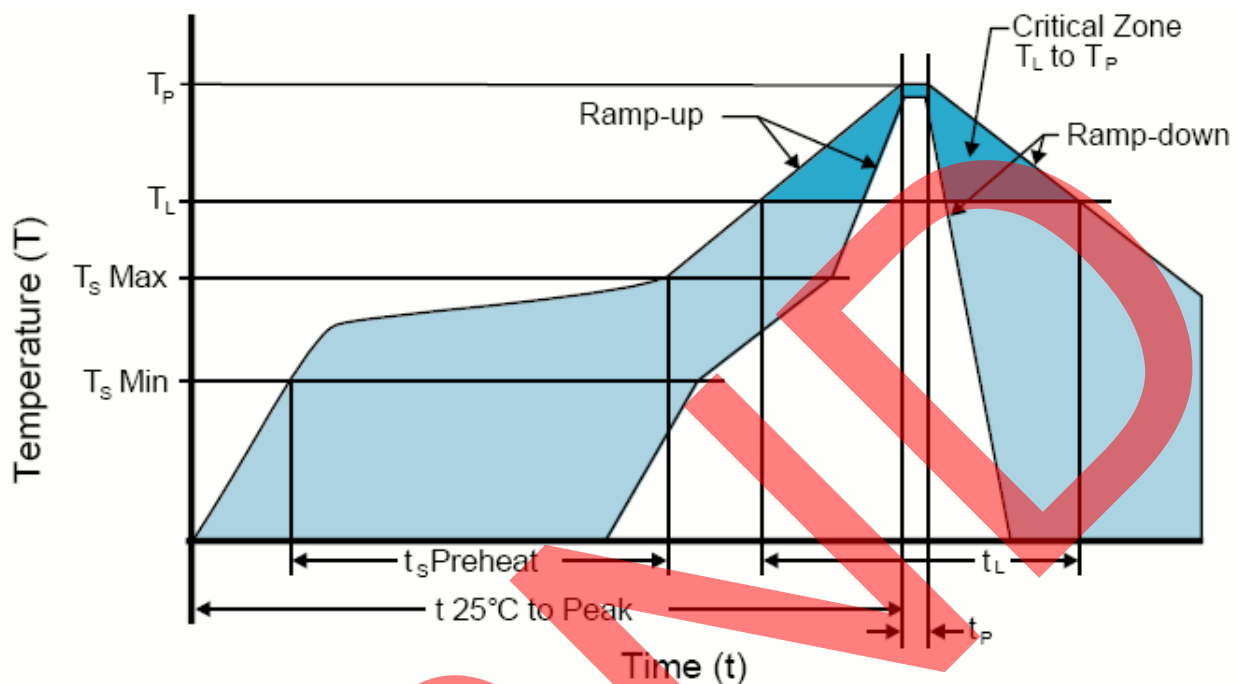

**LOW TEMPERATURE INFRARED/CONVECTION**

<b><math>T_S \text{ MAX}</math> to <math>T_L</math> (Ramp-up Rate)</b>	5°C/Second Maximum
<b>Preheat</b>	
- Temperature Minimum ( $T_S \text{ MIN}$ )	N/A
- Temperature Typical ( $T_S \text{ TYP}$ )	150°C
- Temperature Maximum ( $T_S \text{ MAX}$ )	N/A
- Time ( $t_s \text{ MIN}$ )	60 - 120 Seconds
<b>Ramp-up Rate (<math>T_L</math> to <math>T_P</math>)</b>	5°C/Second Maximum
<b>Time Maintained Above:</b>	
- Temperature ( $T_L$ )	150°C
- Time ( $t_L$ )	200 Seconds Maximum
<b>Peak Temperature (<math>T_P</math>)</b>	240°C Maximum
<b>Target Peak Temperature (<math>T_P \text{ Target}</math>)</b>	240°C Maximum 2 Times / 230°C Maximum 1 Time
<b>Time within 5°C of actual peak (<math>t_P</math>)</b>	10 Seconds Maximum 2 Times / 80 Seconds Maximum 1 Time
<b>Ramp-down Rate</b>	5°C/Second Maximum
<b>Time 25°C to Peak Temperature (<math>t</math>)</b>	N/A
<b>Moisture Sensitivity Level</b>	Level 1
<b>Additional Notes</b>	Temperatures shown are applied to body of device.

**Low Temperature Manual Soldering**

185°C Maximum for 10 Seconds Maximum, 2 times Maximum. (Temperatures shown are applied to body of device.)

## X-ON Electronics

Largest Supplier of Electrical and Electronic Components

*Click to view similar products for [Standard Clock Oscillators](#) category:*

*Click to view products by [Abracon](#) manufacturer:*

Other Similar products are found below :

[601252](#) [F335-12](#) [F335-25](#) [F535L-33.333](#) [F535L-50](#) [ASV-20.000MHZ-LR-T](#) [ECS-2018-160-BN-TR](#) [MXO45HS-2C-66.6666MHZ](#)  
[SiT8209AI-32-33E-125.000000](#) [SIT8918AA-11-33S-50.000000G](#) [SM4420TEV-40.0M-T1K](#) [F335-24](#) [F335-40](#) [F535L-10](#) [F535L-12](#) [F535L-16](#) [F535L-24](#) [F535L-27](#) [F535L-48](#) [PE7744DW-100.0M](#) [CSX-750FCC14745600T](#) [ASF1-3.686MHZ-N-K-S](#) [XO57CTECNA3M6864](#) [ECS-2100A-147.4](#) [601251](#) [EP16E7E2H26.000MTR](#) [SIT8918AA-11-33S-16.000000G](#) [XO3003](#) [9120AC-2D2-33E212.500000](#) [9102AI-243N25E100.00000](#) [8208AC-82-18E-25.00000](#) [ASDK2-32.768KHZ-LR-T3](#) [8008AI-72-XXE-24.545454E](#) [8004AC-13-33E-133.33000X](#) [AS-4.9152-16-SMD-TR](#) [ASFL1-48.000MHZ-LC-T](#) [SIT8920AM-31-33E-25.0000](#) [DSC1028DI2-019.2000](#) [9121AC-2C3-25E100.00000](#) [9102AI-233N33E100.00000X](#) [9102AI-233N25E200.00000](#) [9102AI-232H25S125.00000](#) [9102AI-133N25E200.00000](#) [9102AC-283N25E200.00000](#) [9001AC-33-33E1-30.000](#) [XLH536125.000JS4I](#) [3921AI-2CF-33NZ125.000000](#) [5730-1SF](#) [PXA000010](#) [SIT1602BC-83-33E-10.000000Y](#)