

REGULATORY COMPLIANCE

 Lead Free COMPLIANT	 EU RoHS 2011/65 + 2015/863 COMPLIANT	 China RoHS COMPLIANT	 REACH SVHC COMPLIANT	 DRC CONFLICT FREE
--	--	--	--	--

ITEM DESCRIPTION

MEMS Clock Oscillators LVCMOS (CMOS) 3.3Vdc 4 Pad 2.5mm x 3.2mm Plastic Surface Mount (SMD)

ELECTRICAL SPECIFICATIONS

Nominal Frequency	1MHz to 137MHz
Frequency Tolerance/Stability	Inclusive of all conditions: Calibration Tolerance at 25°C, Frequency Stability over the Operating Temperature Range, Supply Voltage Change, and Output Load Change ±100ppm Maximum over 0°C to +70°C ±50ppm Maximum over 0°C to +70°C ±25ppm Maximum over 0°C to +70°C ±20ppm Maximum over 0°C to +70°C ±100ppm Maximum over -20°C to +70°C ±50ppm Maximum over -20°C to +70°C ±25ppm Maximum over -20°C to +70°C ±20ppm Maximum over -20°C to +70°C ±100ppm Maximum over -40°C to +85°C ±50ppm Maximum over -40°C to +85°C ±25ppm Maximum over -40°C to +85°C ±20ppm Maximum over -40°C to +85°C ±100ppm Maximum over -40°C to +105°C ±50ppm Maximum over -40°C to +105°C ±25ppm Maximum over -40°C to +105°C ±20ppm Maximum over -40°C to +105°C ±100ppm Maximum over -40°C to +125°C ±50ppm Maximum over -40°C to +125°C ±25ppm Maximum over -40°C to +125°C ±20ppm Maximum over -40°C to +125°C ±100ppm Maximum over -55°C to +125°C ±50ppm Maximum over -55°C to +125°C ±25ppm Maximum over -55°C to +125°C
Aging at 25°C	±1.5ppm Maximum First Year
Supply Voltage	3.3Vdc ±10%
Input Current	No Load 5mA Maximum over Nominal Frequency of 1MHz to 20MHz 6mA Maximum over Nominal Frequency of 20.000001MHz to 50MHz 7mA Maximum over Nominal Frequency of 50.000001MHz to 80MHz 9mA Maximum over Nominal Frequency of 80.000001MHz to 137MHz
Output Voltage Logic High (V_{OH})	IOH = -4mA 90% of Vdd Minimum
Output Voltage Logic Low (V_{OL})	IOL = +4mA 10% of Vdd Maximum
Rise/Fall Time	Measured from 20% to 80% of waveform 1.2nSec Typical, 3nSec Maximum
Duty Cycle	Measured at 50% of waveform 50 ±10(%) 50 ±5(%)
Load Drive Capability	15pF Maximum
Output Logic Type	CMOS
Output Control Function	Tri-State (Disabled Output: High Impedance) Power Down (Disabled Output: Logic Low)
Output Control Input Voltage Logic High (V_{Ih})	70% of Vdd Minimum or No Connect to Enable Output

Output Control Input Voltage Logic Low (Vil)	30% of Vdd Maximum to Disable Output
Power Down Output Enable Time	5mSec Maximum (Disabled Output: Logic Low)
Tri-State Output Enable Time	150nSec Maximum (Disabled Output: High Impedance)
Power Down Output Disable Time	150nSec Maximum (Disabled Output: Logic Low)
Tri-State Output Disable Time	150nSec Maximum (Disabled Output: High Impedance)
Standby Current	10µA Maximum (Disabled Output: Logic Low)
Period Jitter (RMS)	2pSec Typical, 4pSec Maximum
RMS Phase Jitter (Fj = 900kHz to 7.5MHz; Random)	0.5pSec Typical, 1pSec Maximum
RMS Phase Jitter (Fj = 12kHz to 20MHz; Random)	1.5pSec Typical, 3pSec Maximum
Start Up Time	5mSec Maximum
Storage Temperature Range	-65°C to +150°C

PART NUMBERING GUIDE

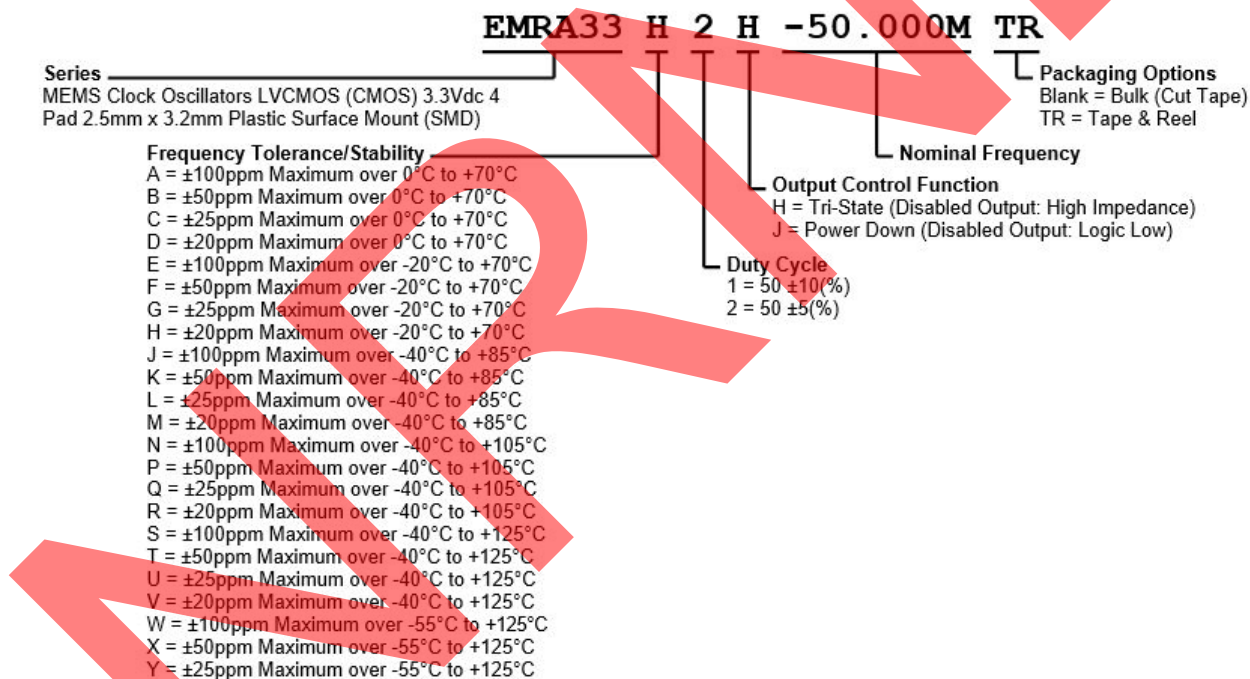

MECHANICAL DIMENSIONS

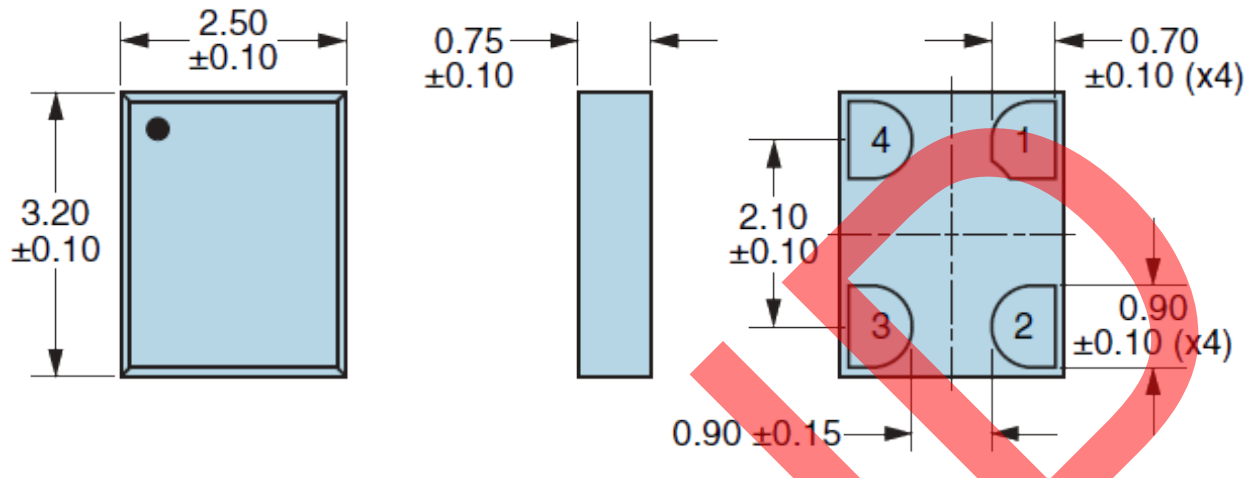

SUGGESTED SOLDER PAD LAYOUT

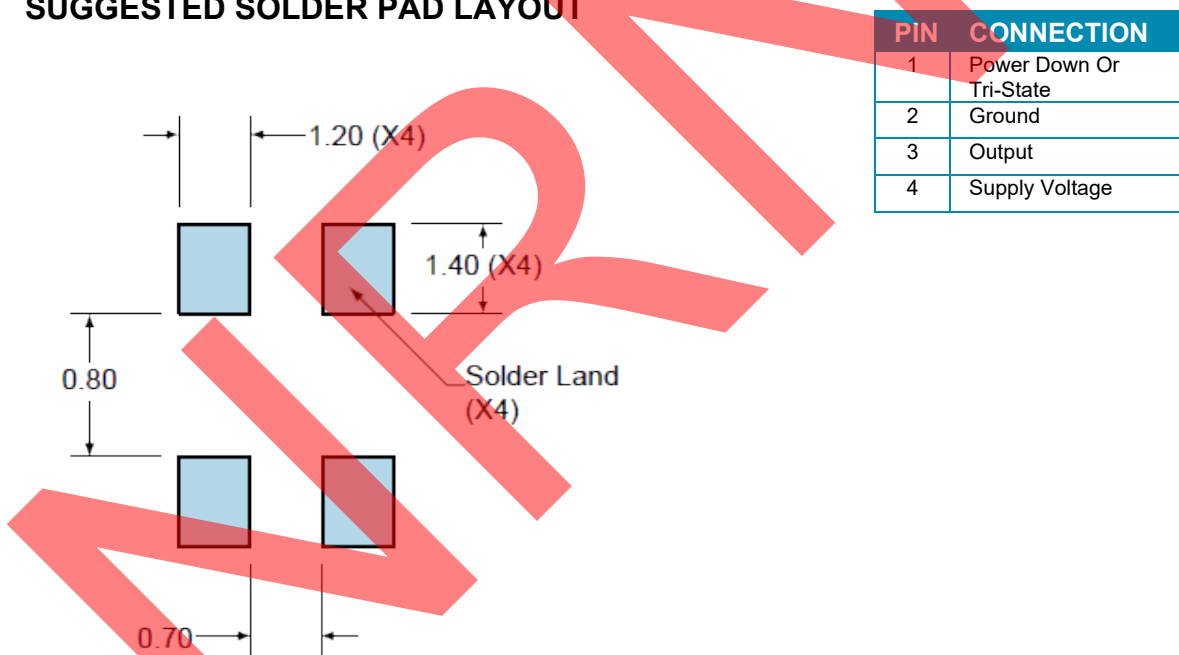

PIN	CONNECTION
1	Power Down Or Tri-State
2	Ground
3	Output
4	Supply Voltage

All Tolerances are ± 0.1

All Dimensions in Millimeters

OUTPUT WAVEFORM & TIMING DIAGRAM



TEST CIRCUIT FOR CMOS OUTPUT

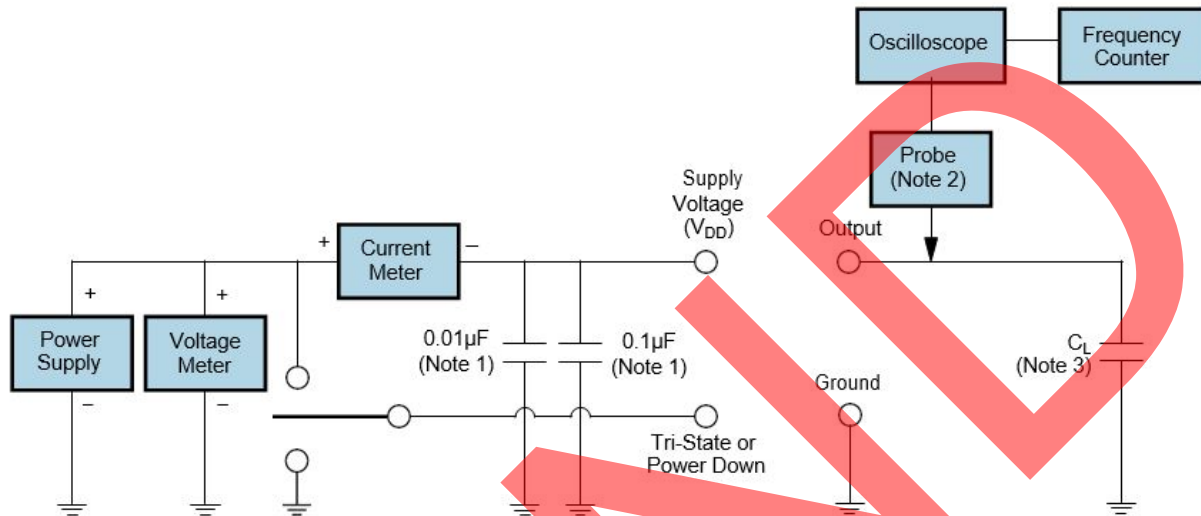

- Note 1:** An external 0.01µF ceramic bypass capacitor in parallel with a 0.1µF high frequency ceramic bypass capacitor close (less than 2mm) to the package ground and supply voltage pin is required.
- Note 2:** A low input capacitance (<12pF), 10X Attenuation Factor, High Impedance (>10Mohms), and High bandwidth (>300MHz) Passive probe is recommended.
- Note 3:** Capacitance value C_L includes sum of all probe and fixture capacitance. See applicable specification sheet for 'Load Drive Capability'.

TAPE & REEL DIMENSIONS

Quantity per Reel: 1,000 Units

All Dimensions in Millimeters

Compliant to EIA-481

X = 8.00 or 12 (±0.30)

Y = 3.50 or 5.5 (±0.05)

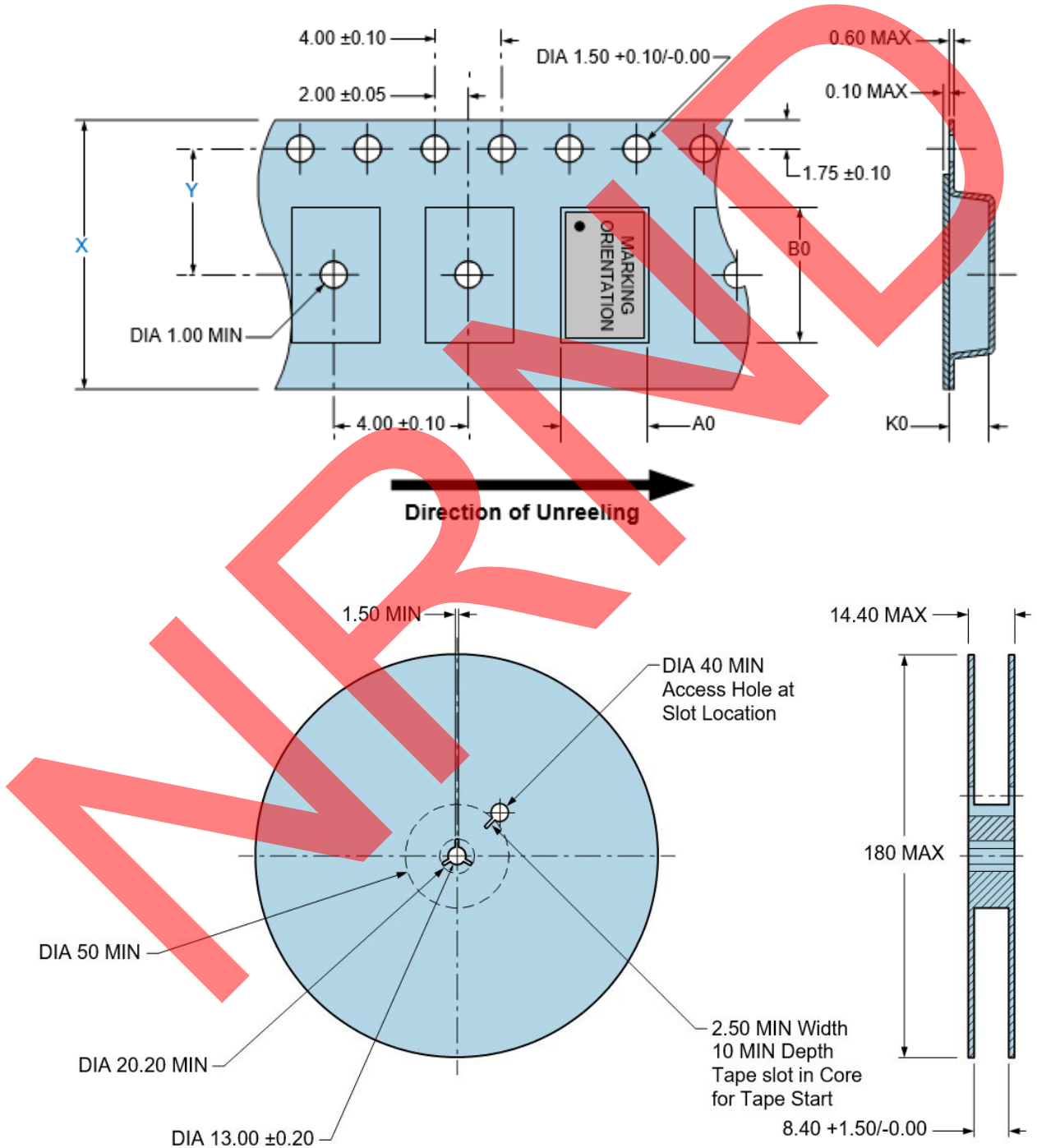

RECOMMENDED SOLDER REFLOW METHOD

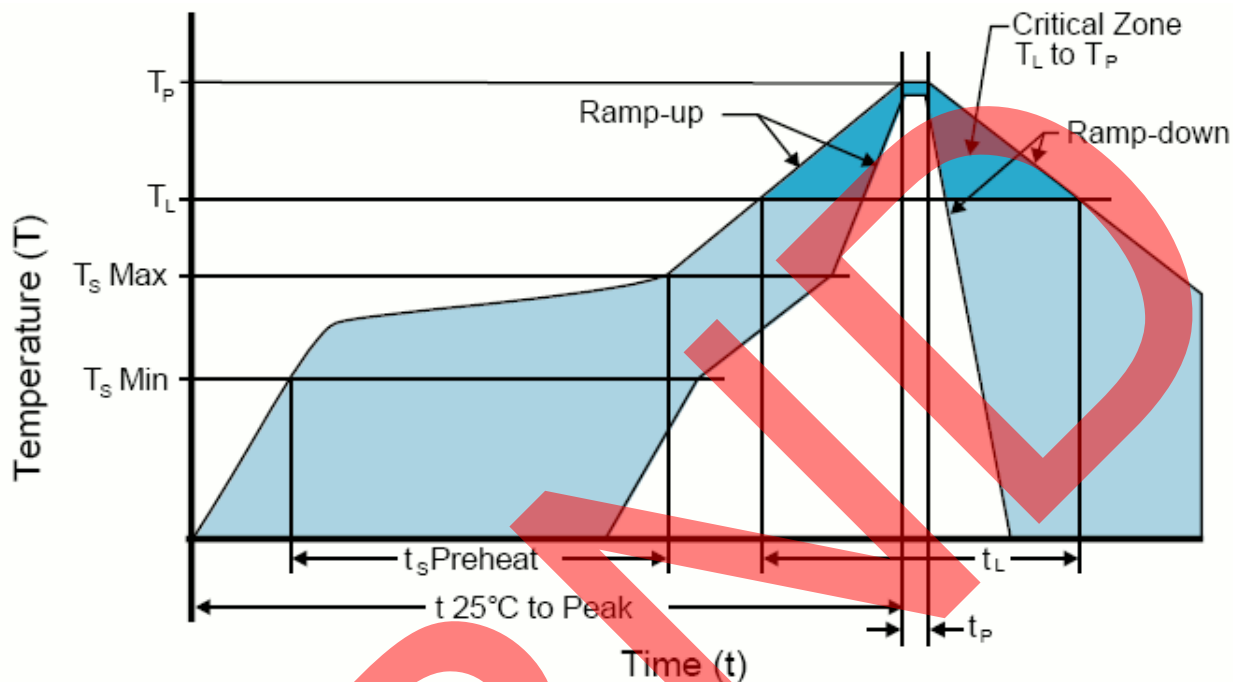

HIGH TEMPERATURE INFRARED/CONVECTION

$T_S \text{ MAX}$ to T_L (Ramp-up Rate)	3°C/Second Maximum
Preheat	
- Temperature Minimum ($T_S \text{ MIN}$)	150°C
- Temperature Typical ($T_S \text{ TYP}$)	175°C
- Temperature Maximum ($T_S \text{ MAX}$)	200°C
- Time ($t_s \text{ MIN}$)	60 - 180 Seconds
Ramp-up Rate (T_L to T_P)	3°C/Second Maximum
Time Maintained Above:	
- Temperature (T_L)	217°C
- Time (t_L)	60 - 150 Seconds
Peak Temperature (T_P)	260°C Maximum for 10 Seconds Maximum
Target Peak Temperature ($T_P \text{ Target}$)	250°C +0/-5°C
Time within 5°C of actual peak (t_P)	20 - 40 Seconds
Ramp-down Rate	6°C/Second Maximum
Time 25°C to Peak Temperature (t)	8 Minutes Maximum
Moisture Sensitivity Level	Level 1
Additional Notes	Temperatures shown are applied to body of device.

High Temperature Manual Soldering

260°C Maximum for 5 Seconds Maximum, 2 times Maximum. (Temperatures shown are applied to body of device.)

RECOMMENDED SOLDER REFLOW METHOD

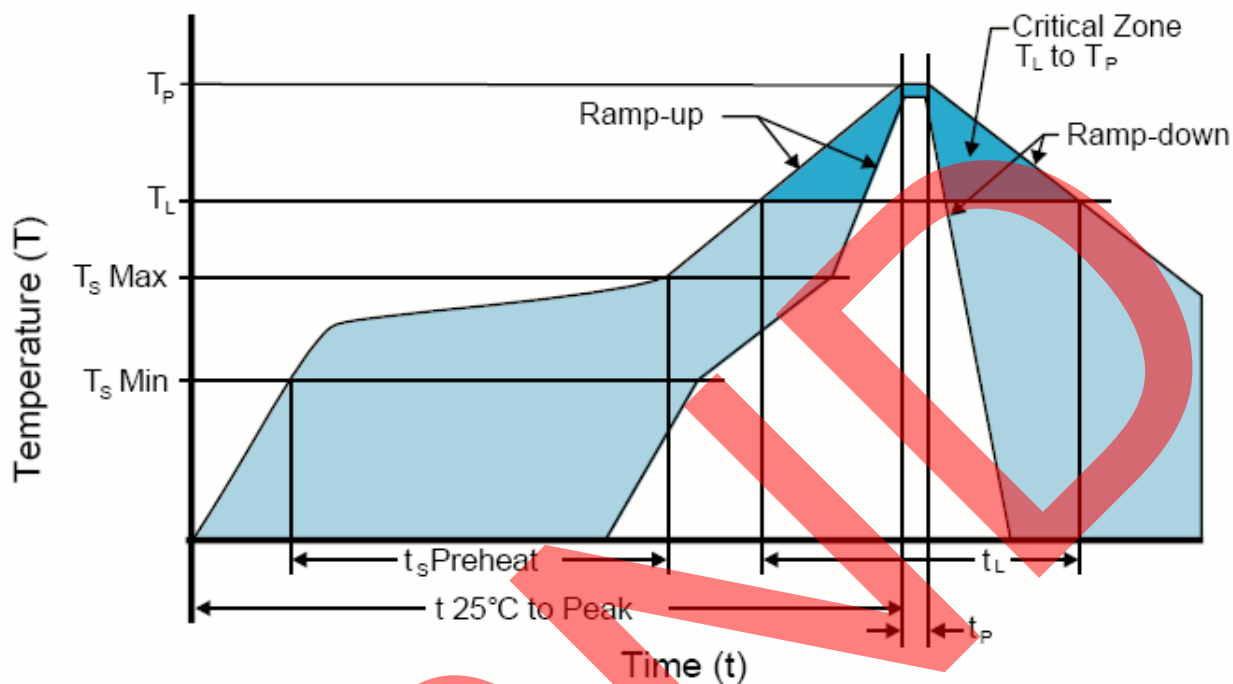

LOW TEMPERATURE INFRARED/CONVECTION

$T_S \text{ MAX to } T_L$ (Ramp-up Rate)	5°C/Second Maximum
Preheat	
- Temperature Minimum ($T_S \text{ MIN}$)	N/A
- Temperature Typical ($T_S \text{ TYP}$)	150°C
- Temperature Maximum ($T_S \text{ MAX}$)	N/A
- Time ($t_s \text{ MIN}$)	60 - 120 Seconds
Ramp-up Rate (T_L to T_P)	5°C/Second Maximum
Time Maintained Above:	
- Temperature (T_L)	150°C
- Time (t_L)	200 Seconds Maximum
Peak Temperature (T_P)	240°C Maximum
Target Peak Temperature ($T_P \text{ Target}$)	240°C Maximum 2 Times / 230°C Maximum 1 Time
Time within 5°C of actual peak (t_P)	10 Seconds Maximum 2 Times / 80 Seconds Maximum 1 Time
Ramp-down Rate	5°C/Second Maximum
Time 25°C to Peak Temperature (t)	N/A
Moisture Sensitivity Level	Level 1
Additional Notes	Temperatures shown are applied to body of device.

Low Temperature Manual Soldering

185°C Maximum for 10 Seconds Maximum, 2 times Maximum. (Temperatures shown are applied to body of device.)

X-ON Electronics

Largest Supplier of Electrical and Electronic Components

Click to view similar products for [Standard Clock Oscillators](#) category:

Click to view products by [Abracon](#) manufacturer:

Other Similar products are found below :

[601252](#) [F335-12](#) [F335-25](#) [F535L-33.333](#) [F535L-50](#) [ASV-20.000MHZ-LR-T](#) [ECS-2018-160-BN-TR](#) [EL13C7-H2F-125.00M](#) [MXO45HS-2C-66.6666MHZ](#) [SiT8209AI-32-33E-125.000000](#) [SM4420TEV-40.0M-T1K](#) [F335-24](#) [F335-40](#) [F535L-10](#) [F535L-12](#) [F535L-16](#) [F535L-24](#) [F535L-27](#) [F535L-48](#) [PE7744DW-100.0M](#) [CSX-750FCC14745600T](#) [ASF1-3.686MHZ-N-K-S](#) [XO57CTECNA3M6864](#) [ECS-2100A-147.4](#) [601251](#) [EP16E7E2H26.000MTR](#) [SIT8918AA-11-33S-16.000000G](#) [XO3003](#) [9120AC-2D2-33E212.500000](#) [9102AI-243N25E100.00000](#) [8208AC-82-18E-25.00000](#) [ASDK2-32.768KHZ-LR-T3](#) [8008AI-72-XXE-24.545454E](#) [8004AC-13-33E-133.33000X](#) [AS-4.9152-16-SMD-TR](#) [ASFL1-48.000MHZ-LC-T](#) [SIT8920AM-31-33E-25.0000](#) [DSC1028DI2-019.2000](#) [9121AC-2C3-25E100.00000](#) [9102AI-233N33E100.00000X](#) [9102AI-233N25E200.00000](#) [9102AI-232H25S125.00000](#) [9102AI-133N25E200.00000](#) [9102AC-283N25E200.00000](#) [9001AC-33-33E1-30.000](#) [XLH536125.000JS4I](#) [3921AI-2CF-33NZ125.000000](#) [5730-1SF](#) [PXA000010](#) [XLH535050.000000X](#)