

Pierce Analyzer System (PAS) - Advanced Board Characterization Service

EXPEDITED-PAS-SVC
STANDARD-PAS-SVC

Introduction

The majority of electronic designs have some form of timing associated with them. Depending on the frequency accuracy requirements, some employ oscillators while others use off-the-shelf crystals in conjunction with the built-in oscillator circuit; embedded in most μ controllers and μ processors.

Most if not all embedded solutions use the Pierce Oscillator configuration, integrated as part of the SOC (system on chip). The obvious advantages include cost, size and power compared to a stand-alone oscillator; while the key limitation is the proper matching of the quartz crystal with the on-board Pierce Oscillator.

Figure (1) outlines the oscillator block and the key components that influence the overall performance of the timing loop.

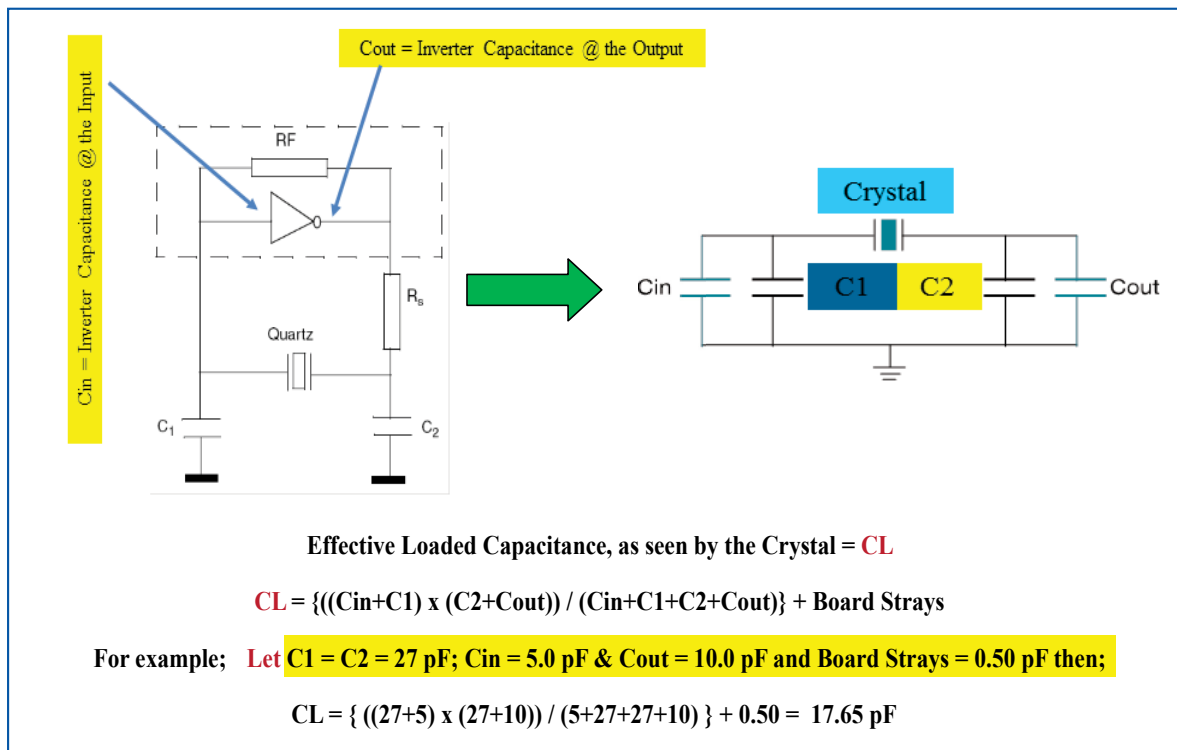

Therefore specifying a crystal with 18.0 pF plating load capacitance would be the closest match for frequency accuracy.

Besides the frequency accuracy issue, while accounting for Quartz Crystal's set tolerance; the reactive impedance (X_c) of the loop capacitors, in combination with the Inverter Amplifier's transconductance (g_m), the current limiting resistor R_s and the presence or absence of the AGC or ALC circuit as part of the oscillator loop – determines the boundary condition of the design.

This boundary condition, commonly referred to as the Safety Factor (SF), is an important parameter to ensure that the product design has sufficient margin to accommodate part-to-part and lot-to-lot variations; as well as eliminating product performance uncertainty in production volume.

Pierce Analyzer System (PAS) - Advanced Board Characterization Service

EXPEDITED-PAS-SVC
STANDARD-PAS-SVC

Historically, design engineers have optimized their circuit performance via trial & error, at the expense of significant investment in time. Further, to properly determine the oscillator loop dynamics, there is no other choice but to break the oscillator loop and make key measurements using specialized equipment such as a Current Probe.

Lastly, these measurements become increasingly sensitive if the timing loop is driven by a Tuning Fork (32.768kHz) crystal. These crystals are extremely sensitive to loading effects and to accurately determine the in-circuit behavior of these components, extreme care and accuracy is essential.

For instance, Automotive, Medical and Consumer Electronics solutions typically utilize Tuning Fork Crystals for their Real-Time-Clocking (RTC) needs. If the selected SOC has inadequate gain margin, there is a high probability that some percentage of these Crystals will not properly start under adverse conditions, such as low operating temperature.

Another example would be a Zigbee based design which has a hard boundary condition of ± 40 ppm relative to the carrier, for proper operation. If the oscillator loop is not optimized, most of the ± 40 ppm can be consumed by tolerance alone; thereby causing significant fall out in the field.

In summary, a typical product launch requires significant investment of capital and design resources. Making a very modest investment in characterizing the timing loop **is a must have** to protect this investment, as well as mitigate risk of field failures or warranty re-calls.

Solution

To overcome these barriers and provide an accurate assessment of the oscillator loop dynamics; Abracon's Advanced Engineering Team has developed a Proprietary Pierce Analyzer System (PAS); which is designed to analyze both the stand alone crystal, as well as the performance of that particular crystal in customer's circuit.

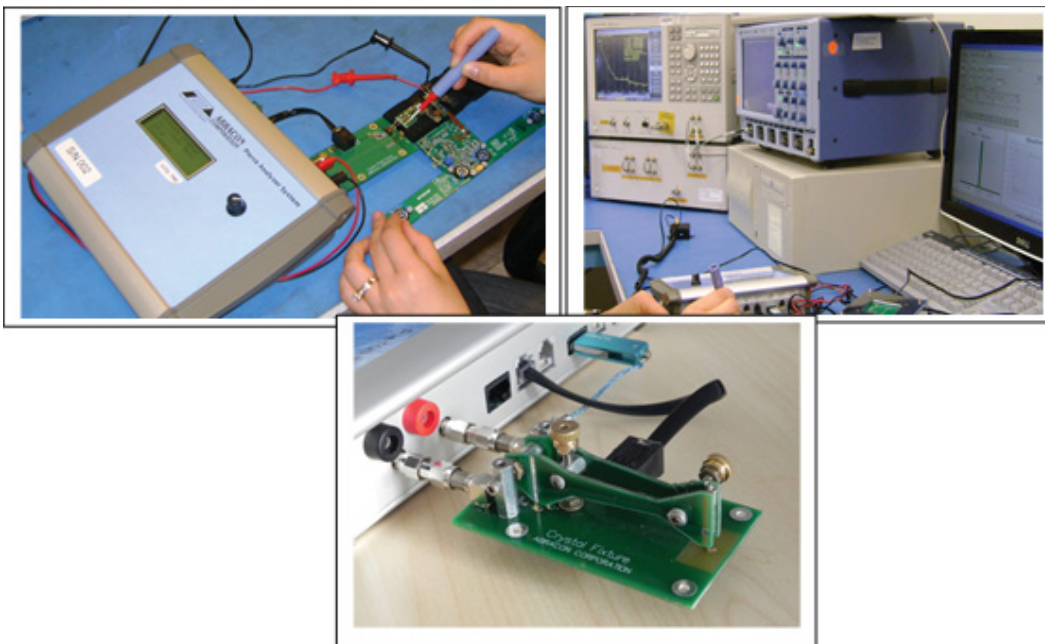

Pierce Analyzer System (PAS) - Advanced Board Characterization Service

EXPEDITED-PAS-SVC
STANDARD-PAS-SVC

Features

- Circuit characterization; providing best possible match between Quartz Crystal, oscillator loop and associated components
- Eliminates probability of oscillator start-up issues related to inadequate design or marginal component performance
- Eliminates production launch issues related to crystal oscillator based timing circuit
- Solves for design margin uncertainty
- Provides customer's oscillator circuit overview in the form of a detailed report, which could be an ideal 3rd party assessment for the design history file or PPAP documentation. This report encompasses both the stand-alone crystal performance, as well as in-circuit behavior outlining safety factor as a function of crystal's ESR, etc.
- For additional information, please contact Abracon at: tech-support@abracon.com

Deliverables

Abracon provides a detailed test report encompassing:

- **Stand alone Quartz Crystal characteristics including:**

- Motional parameters (Cm, Lm, ESR & Co)
- Narrow Band Frequency Response Plot
- Wide Band Frequency Response Plot Admittance versus Susceptance Plot
- Frequency dependence versus load capacitance plot

- **Oscillator loop**

- Initial frequency accuracy and drive level as seen by the crystal with measured ESR
- Worst case projected drive level with maximum specified ESR
- Safety Factor of the oscillator loop under both typical and maximum ESR
- Recommendation on proper component selection (C1, C2 & Rs when applicable) for best compromise with respect to Safety Factor and Frequency accuracy
- Recommendation on the Abracon Crystal part # with proper plating load and other key attributes to enable the most robust design, specific to the μ controller/processor implemented

Ordering Info

EXPEDITED-PAS-SVC
STANDARD-PAS-SVC

ATTENTION: Abracon LLC's products are COTS – Commercial-Off-The-Shelf products; suitable for Commercial, Industrial and, where designated, Automotive Applications. Abracon's products are not specifically designed for Military, Aviation, Aerospace, Life-dependent Medical applications or any application requiring high reliability where component failure could result in loss of life and/or property. For applications requiring high reliability and/or presenting an extreme operating environment, written consent and authorization from Abracon LLC is required. Please contact Abracon LLC for more information.



5101 Hidden Creek Ln Spicewood TX 78669
Phone: 512-371-6159 | Fax: 512-351-8858
For terms and conditions of sales, please visit:
www.abracon.com

REVISED: 08-7-19

ABRACON IS
ISO9001-2015
CERTIFIED

X-ON Electronics

Largest Supplier of Electrical and Electronic Components

Click to view similar products for [Crystals](#) category:

Click to view products by [ABRACON](#) manufacturer:

Other Similar products are found below :

[CS325S24000000ABJT](#) [718-13.2-1](#) [MC405 32.0000K-R3:PURE SN](#) [FC-135R 32.7680KF-A3](#) [7A-40.000MAAE-T](#) [7B-27.000MBBK-T](#)
[FL2000085](#) [9B-15.360MBBK-B](#) [9C-7.680MBBK-T](#) [ASH7K-32.768KHZ](#) [AT-41.600MAGQ-T](#) [BTD1062E05A-513](#) [LFXTAL066198Cutt](#)
[9C-14.31818MBBK-T](#) [FA-238 50.0000MB30X-K3](#) [FC-12M 32.7680KA-AC3](#) [SSPT7F-9PF20-R](#) [FX325BS-38.88EEM1201](#)
[LFXTAL065253Cutt](#) [LFXTAL066431Cutt](#) [XT9S20ANA14M7456](#) [XT9SNLANA16M](#) [646G-24-2](#) [7A-24.576MBBK-T](#) [7B-30.000MBBK-T](#)
[WX26-32.768K-6PF](#) [9B-14.31818MBBK-B](#) [CD1AM](#) [7B-25.000MAAE-T](#) [7A-14.31818MBBK-T](#) [6504-202-1501](#) [6526-202-1501](#) [FA-118T](#)
[27.1200MB50P-K0](#) [FC-135R 32.7680KA-A3](#) [ABM12-104-37.400MHZT](#) [ABLS-10.000MHZ-D3W-T](#) [BTJ112E01E-513](#) [BTJ722K01C-7067](#)
[BTL-20-513](#) [TSX-3225 24.0000MF15X-AC](#) [TSX-3225 16.0000MF18X-AC](#) [BTJ120E02C](#) [BTL-12-513](#) [7A-10.000MBBK-T](#) [7A-](#)
[11.0592MBBK-T](#) [ABM12-103-24.000MHZT](#) [CS325S25000000ABJT](#) [ABM3B-25.000MHZ-B2-X-T](#) [FC-135 32.7680KA-A5](#) [FX0800015](#)