

FEATURES

- Up to 40V Input Voltage
- Up to 1.5A Constant Output Current
- Output Voltage up to 12V
- Patent Pending ActiveCC Constant Current Control
 - Integrated Current Control Improves Efficiency, Lowers Cost, and Reduces Component Count
- Resistor Programmable Outputs
 - Current Limit from 400mA to 1500mA
 - Patented cable Compensation from DC Cable Compensation from 0Ω to 0.5Ω
- 2% Feedback Voltage Accuracy
- Up to 93% Efficiency
- 210kHz Switching Frequency Eases EMI Design
- Advanced Feature Set
 - Integrated Soft Start
 - Thermal Shutdown
 - Secondary Cycle-by-Cycle Current Limit
 - Protection Against Shorted ISET Pin
- SOP-8 Package

APPLICATIONS

- Car Charger / Adaptor
- Rechargeable Portable Devices
- General-Purpose CC/CV Power Supply

GENERAL DESCRIPTION

ACT4514 is a wide input voltage, high efficiency ActiveCC step-down DC/DC converter that operates in either CV (Constant Output Voltage) mode or CC (Constant Output Current) mode. ACT4514 provides up to 1.5A output current at 210kHz switching frequency.

ActiveCC is a patent-pending control scheme to achieve highest accuracy sensorless constant current control. ActiveCC eliminates the expensive, high accuracy current sense resistor, making it ideal for battery charging applications and high-brightness LED drive for architectural lighting. The ACT4514 achieves higher efficiency than traditional constant current switching regulators by eliminating the sense resistor and its associated power loss.

Protection features include cycle-by-cycle current limit, thermal shutdown, and frequency foldback at short circuit. The devices are available in a SOP-8 package and require very few external devices for operation.

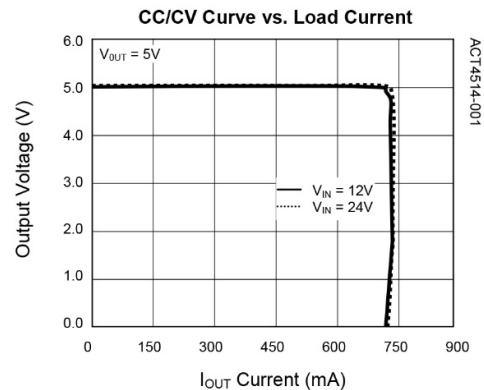
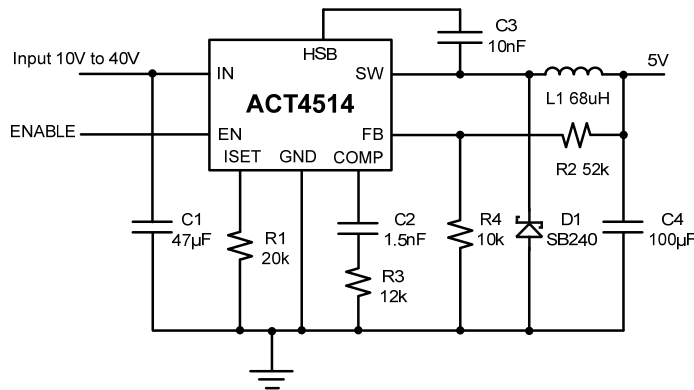

ORDERING INFORMATION

PART NUMBER	TEMPERATURE RANGE	PACKAGE	PINS	PACKING
ACT4514SH-T	-40°C to 85°C	SOP-8	8	TAPE & REEL

PIN CONFIGURATION

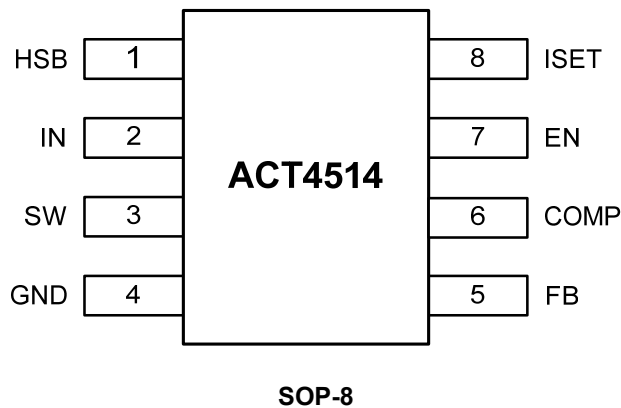

PIN DESCRIPTIONS

PIN	NAME	DESCRIPTION
1	HSB	High Voltage Bias Pin. This provides power to the internal high-side MOSFET gate driver. Connect a 10nF capacitor from HSB pin to SW pin.
2	IN	Power Supply Input. Bypass this pin with a 10µF ceramic capacitor to GND, placed as close to the IC as possible.
3	SW	Power Switching Output to External Inductor.
4	GND	Ground. Connect this pin to a large PCB copper area for best heat dissipation. Return FB, COMP, and ISET to this GND, and connect this GND to power GND at a single point for best noise immunity.
5	FB	Feedback Input. The voltage at this pin is regulated to 0.808V. Connect to the resistor divider between output and GND to set the output voltage.
6	COMP	Error Amplifier Output. This pin is used to compensate the converter.
7	EN	Enable Input. EN is pulled up to 5V with a 4µA current, and contains a precise 0.8V logic threshold. Drive this pin to a logic-high or leave unconnected to enable the IC. Drive to a logic-low to disable the IC and enter shutdown mode.
8	ISET	Output Current Setting Pin. Connect a resistor from ISET to GND to program the output current.

ABSOLUTE MAXIMUM RATING^①

PARAMETER	VALUE	UNIT
IN to GND	-0.3 to 40	V
SW to GND	-1 to $V_{IN} + 1$	V
HSB to GND	$V_{SW} - 0.3$ to $V_{SW} + 7$	V
FB, EN, ISET, COMP to GND	-0.3 to +6	V
Junction to Ambient Thermal Resistance	105	°C/W
Operating Junction Temperature	-40 to 150	°C
Storage Junction Temperature	-55 to 150	°C
Lead Temperature (Soldering 10 sec.)	300	°C

①: Do not exceed these limits to prevent damage to the device. Exposure to absolute maximum rating conditions for long periods may affect device reliability.

ELECTRICAL CHARACTERISTICS

($V_{IN} = 14V$, $T_A = 25^{\circ}C$, unless otherwise specified.)

PARAMETER	TEST CONDITIONS	MIN	TYP	MAX	UNIT
Input Voltage		10		40	V
V_{IN} UVLO Turn-On Voltage	Input Voltage Rising	9.05	9.35	9.65	V
V_{IN} UVLO Hysteresis	Input Voltage Falling		1.1		V
Standby Supply Current	$V_{EN} = 3V$, $V_{FB} = 1V$		1.0		mA
	$V_{EN} = 3V$, $V_O = 5V$, No load		2.5		mA
Shutdown Supply Current	$V_{EN} = 0V$		75	100	μA
Feedback Voltage		792	808	824	mV
Internal Soft-Start Time			400		μs
Error Amplifier Transconductance	$V_{FB} = V_{COMP} = 0.8V$, $\Delta I_{COMP} = \pm 10\mu A$		650		$\mu A/V$
Error Amplifier DC Gain			4000		V/V
Switching Frequency	$V_{FB} = 0.808V$	190	210	240	kHz
Foldback Switching Frequency	$V_{FB} = 0V$		30		kHz
Maximum Duty Cycle		82	85	88	%
Minimum On-Time			200		ns
COMP to Current Limit Transconductance	$V_{COMP} = 1.2V$		1.75		A/V
Switch Current Limit	Duty = 50%		1.8		A
Slope Compensation	Duty = D_{MAX}		0.75		A
ISET Voltage			1		V
ISET to IOOUT DC Room Temp Current Gain	IOOUT / ISET		25000		A/A
EN Threshold Voltage	EN Pin Rising	0.75	0.8	0.85	V
EN Hysteresis	EN Pin Falling		80		mV
EN Internal Pull-up Current			4		μA
High-Side Switch ON-Resistance			0.3		Ω
SW Off Leakage Current	$V_{EN} = V_{SW} = 0V$		1	10	μA
Thermal Shutdown Temperature	Temperature Rising		155		$^{\circ}C$

FUNCTIONAL BLOCK DIAGRAM

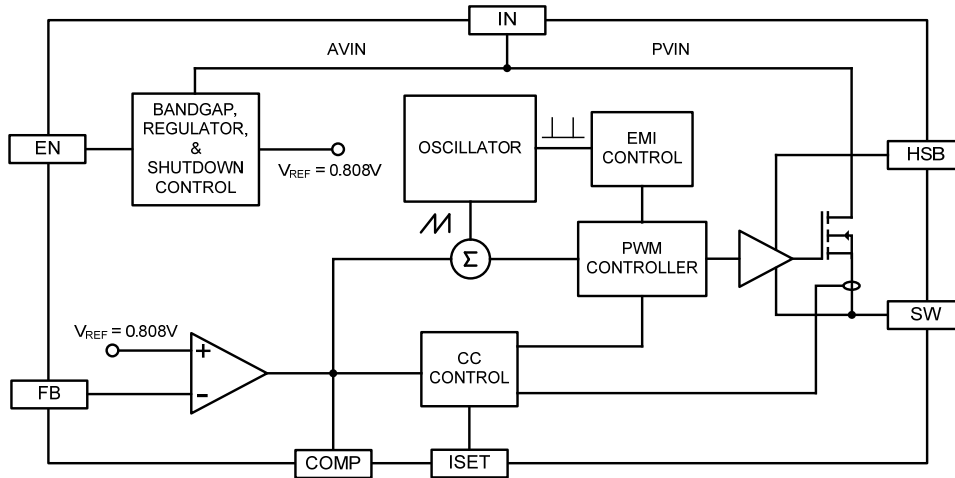

FUNCTIONAL DESCRIPTION

CV/CC Loop Regulation

As seen in *Functional Block Diagram*, the ACT4514 is a peak current mode pulse width modulation (PWM) converter with CC and CV control. The converter operates as follows:

A switching cycle starts when the rising edge of the Oscillator clock output causes the High-Side Power Switch to turn on and the Low-Side Power Switch to turn off. With the SW side of the inductor now connected to IN, the inductor current ramps up to store energy in the magnetic field. The inductor current level is measured by the Current Sense Amplifier and added to the Oscillator ramp signal. If the resulting summation is higher than the COMP voltage, the output of the PWM Comparator goes high. When this happens or when Oscillator clock output goes low, the High-Side Power Switch turns off.

At this point, the SW side of the inductor swings to a diode voltage below ground, causing the inductor current to decrease and magnetic energy to be transferred to output. This state continues until the cycle starts again. The High-Side Power Switch is driven by logic using HSB as the positive rail. This pin is charged to $V_{SW} + 5V$ when the Low-Side Power Switch turns on. The COMP voltage is the integration of the error between FB input and the internal 0.808V reference. If FB is lower than the reference voltage, COMP tends to go higher to increase current to the output. Output current will increase until it reaches the CC limit set by the ISET resistor. At this point, the device will transition

from regulating output voltage to regulating output current, and the output voltage will drop with increasing load.

The Oscillator normally switches at 200kHz. However, if FB voltage is less than 0.6V, then the switching frequency decreases until it reaches a typical value of 30kHz at $V_{FB} = 0.15V$.

Enable Pin

The ACT4514 has an enable input EN for turning the IC on or off. The EN pin contains a precision 0.8V comparator with 75mV hysteresis and a 4μA pull-up current source. The comparator can be used with a resistor divider from V_{IN} to program a startup voltage higher than the normal UVLO value. It can be used with a resistor divider from V_{OUT} to disable charging of a deeply discharged battery, or it can be used with a resistor divider containing a thermistor to provide a temperature-dependent shutoff protection for over temperature battery. The thermistor should be thermally coupled to the battery pack for this usage.

If left floating, the EN pin will be pulled up to roughly 5V by the internal 4μA current source. It can be driven from standard logic signals greater than 0.8V, or driven with open-drain logic to provide digital on/off control.

Thermal Shutdown

The ACT4514 disables switching when its junction temperature exceeds 155°C and resumes when the temperature has dropped by 20°C.

APPLICATIONS INFORMATION

Output Voltage Setting

Figure 1:
Output Voltage Setting

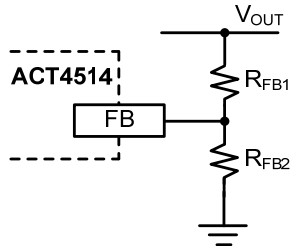

Figure 1 shows the connection for setting the output voltage. Select the proper ratio of the two feedback resistors R_{FB1} and R_{FB2} based on the output voltage. Typically, use $R_{FB2} \approx 10k\Omega$ and determine R_{FB1} from the following equation:

$$R_{FB1} = R_{FB2} \left(\frac{V_{OUT}}{0.808V} - 1 \right) \tag{1}$$

CC Current Setting

ACT4514 constant current value is set by a resistor connected between the ISET pin and GND. The CC output current is linearly proportional to the current flowing out of the ISET pin. The voltage at ISET is roughly 1V and the current gain from ISET to output is roughly 25000 (25mA/1μA). To determine the proper resistor for a desired current, please refer to Figure 2 below.

Figure 2:
Curve for Programming Output CC Current

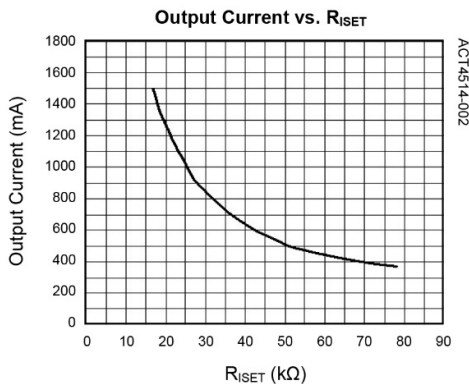

Inductor Selection

The inductor maintains a continuous current to the output load. This inductor current has a ripple that is dependent on the inductance value:

Higher inductance reduces the peak-to-peak ripple current. The trade off for high inductance value is the increase in inductor core size and series resistance, and the reduction in current handling capability. In general, select an inductance value L based on ripple current requirement:

$$L = \frac{V_{OUT} \times (V_{IN} - V_{OUT})}{V_{IN} f_{SW} I_{LOADMAX} K_{RIPPLE}} \tag{2}$$

where V_{IN} is the input voltage, V_{OUT} is the output voltage, f_{SW} is the switching frequency, $I_{LOADMAX}$ is the maximum load current, and K_{RIPPLE} is the ripple factor. Typically, choose $K_{RIPPLE} = 30\%$ to correspond to the peak-to-peak ripple current being 30% of the maximum load current.

With a selected inductor value the peak-to-peak inductor current is estimated as:

$$I_{LPK-PK} = \frac{V_{OUT} \times (V_{IN} - V_{OUT})}{L \times V_{IN} \times f_{SW}} \tag{3}$$

The peak inductor current is estimated as:

$$I_{LPK} = I_{LOADMAX} + \frac{1}{2} I_{LPK-PK} \tag{4}$$

The selected inductor should not saturate at I_{LPK} . The maximum output current is calculated as:

$$I_{OUTMAX} = I_{LIM} - \frac{1}{2} I_{LPK-PK} \tag{5}$$

I_{LIM} is the internal current limit, which is typically 2.5A, as shown in Electrical Characteristics Table.

External High Voltage Bias Diode

It is recommended that an external High Voltage Bias diode be added when the system has a 5V fixed input or the power supply generates a 5V output. This helps improve the efficiency of the regulator. The High Voltage Bias diode can be a low cost one such as IN4148 or BAT54.

APPLICATIONS INFORMATION CONT'D

Figure 3:
External High Voltage Bias Diode

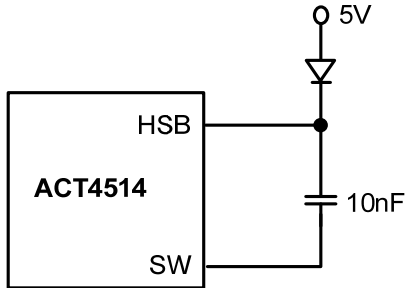

This diode is also recommended for high duty cycle operation and high output voltage applications.

Input Capacitor

The input capacitor needs to be carefully selected to maintain sufficiently low ripple at the supply input of the converter. A low ESR capacitor is highly recommended. Since large current flows in and out of this capacitor during switching, its ESR also affects efficiency.

The input capacitance needs to be higher than 10µF. The best choice is the ceramic type, however, low ESR tantalum or electrolytic types may also be used provided that the RMS ripple current rating is higher than 50% of the output current. The input capacitor should be placed close to the IN and G pins of the IC, with the shortest traces possible. In the case of tantalum or electrolytic types, they can be further away if a small parallel 0.1µF ceramic capacitor is placed right next to the IC.

Output Capacitor

The output capacitor also needs to have low ESR to keep low output voltage ripple. The output ripple voltage is:

$$V_{RIPPLE} = I_{OUTMAX} K_{RIPPLE} R_{ESR} + \frac{V_{IN}}{28 \times f_{SW}^2 LC_{OUT}} \quad (6)$$

where I_{OUTMAX} is the maximum output current, K_{RIPPLE} is the ripple factor, R_{ESR} is the ESR of the output capacitor, f_{SW} is the switching frequency, L is the inductor value, and C_{OUT} is the output capacitance. In the case of ceramic output capacitors, R_{ESR} is very small and does not contribute to the ripple. Therefore, a lower capacitance value can be used for ceramic type. In the case of tantalum or electrolytic capacitors, the ripple is dominated by R_{ESR} multiplied by the ripple current. In that case, the output capacitor is chosen to have sufficiently low ESR.

For ceramic output capacitor, typically choose a capacitance of about 22µF. For tantalum or electrolytic capacitors, choose a capacitor with less than 50mΩ ESR.

Rectifier Diode

Use a Schottky diode as the rectifier to conduct current when the High-Side Power Switch is off. The Schottky diode must have current rating higher than the maximum output current and a reverse voltage rating higher than the maximum input voltage.

STABILITY COMPENSATION

Figure 4:
Stability Compensation

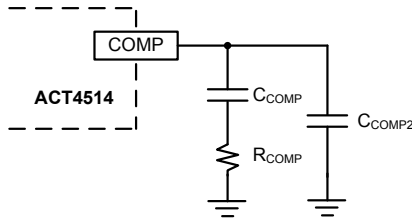

①: C_{COMP2} is needed only for high ESR output capacitor

The feedback loop of the IC is stabilized by the components at the COMP pin, as shown in Figure 3. The DC loop gain of the system is determined by the following equation:

$$A_{VDC} = \frac{0.808 V}{I_{OUT}} A_{VEA} G_{COMP} \quad (7)$$

The dominant pole P1 is due to C_{COMP}:

$$f_{P1} = \frac{G_{EA}}{2\pi A_{VEA} C_{COMP}} \quad (8)$$

The second pole P2 is the output pole:

$$f_{P2} = \frac{I_{OUT}}{2\pi V_{OUT} C_{OUT}} \quad (9)$$

The first zero Z1 is due to R_{COMP} and C_{COMP}:

$$f_{Z1} = \frac{1}{2\pi R_{COMP} C_{COMP}} \quad (10)$$

And finally, the third pole is due to R_{COMP} and C_{COMP2} (if C_{COMP2} is used):

$$f_{P3} = \frac{1}{2\pi R_{COMP} C_{COMP2}} \quad (11)$$

The following steps should be used to compensate the IC:

STEP 1. Set the cross over frequency at 1/10 of the switching frequency via R_{COMP}:

$$R_{COMP} = \frac{2\pi V_{OUT} C_{OUT} f_{SW}}{10 G_{EA} G_{COMP} \times 0.808 V} \quad (12)$$

$$= 2.75 \times 10^8 V_{OUT} C_{OUT} (\Omega)$$

STEP 2. Set the zero f_{Z1} at 1/4 of the cross over frequency. If R_{COMP} is less than 15kΩ, the equation for C_{COMP} is:

$$C_{COMP} = \frac{1.8 \times 10^{-5}}{R_{COMP}} (F) \quad (13)$$

If R_{COMP} is limited to 15kΩ, then the actual cross over frequency is 3.4 / (V_{OUT}C_{OUT}). Therefore:

$$C_{COMP} = 1.2 \times 10^{-5} V_{OUT} C_{OUT} (F) \quad (14)$$

STEP 3. If the output capacitor's ESR is high enough to cause a zero at lower than 4 times the cross over frequency, an additional compensation capacitor C_{COMP2} is required. The condition for using C_{COMP2} is:

$$R_{ESROUT} \geq \text{Min} \left(\frac{1.1 \times 10^{-6}}{C_{OUT}}, 0.012 V_{OUT} \right) (\Omega) \quad (15)$$

And the proper value for C_{COMP2} is:

$$C_{COMP2} = \frac{C_{OUT} R_{ESRCOUT}}{R_{COMP}} \quad (16)$$

Though C_{COMP2} is unnecessary when the output capacitor has sufficiently low ESR, a small value C_{COMP2} such as 100pF may improve stability against PCB layout parasitic effects.

Table 2 shows some calculated results based on the compensation method above.

Table 1:
Typical Compensation for Different Output Voltages and Output Capacitors

V _{OUT}	C _{OUT}	R _{COMP}	C _{COMP}	C _{COMP2} ①
2.5V	22μF Ceramic	8.2kΩ	2.2nF	None
3.3V	22μF Ceramic	12kΩ	1.5nF	None
5V	22μF Ceramic	15kΩ	1.5nF	None
2.5V	47μF SP CAP	15kΩ	1.5nF	None
3.3V	47μF SP CAP	15kΩ	1.8nF	None
5V	47μF SP CAP	15kΩ	2.7nF	None
2.5V	470μF/6.3V/30mΩ	15kΩ	15nF	47pF
3.3V	470μF/6.3V/30mΩ	15kΩ	22nF	47pF
5V	470μF/6.3V/30mΩ	15kΩ	27nF	47pF

①: C_{COMP2} is needed for high ESR output capacitor C_{COMP2} ≤ 47pF is recommended.

STABILITY COMPENSATION CONT'D

CC Loop Stability

The constant-current control loop is internally compensated over the 400mA-1500mA output range. No additional external compensation is required to stabilize the CC current.

Output Cable Resistance Compensation

To compensate for resistive voltage drop across the charger's output cable, the ACT4514 integrates a simple, user-programmable cable voltage drop compensation using the impedance at the FB pin. Use the curve in Figure 4 to choose the proper feedback resistance values for cable compensation. R_{FB1} is the high side resistor of voltage divider.

In the case of high R_{FB1} used, the frequency compensation needs to be adjusted correspondingly. As show in Figure 6, adding a capacitor in paralalled with R_{FB1} or increasing the compensation capacitance at COMP pin helps the system stability.

Figure 5:
Cable Compensation at Various Resistor Divider Values

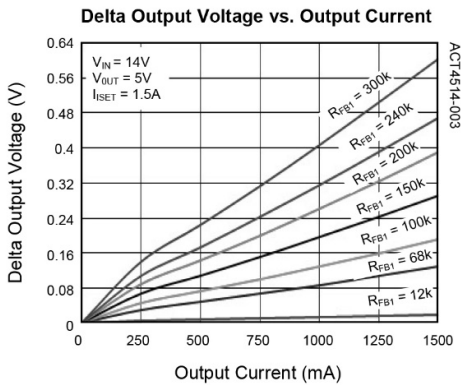
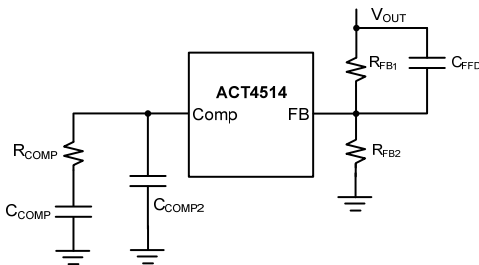

Figure 6:
Frequency Compensation for High R_{FB1}



PC Board Layout Guidance

When laying out the printed circuit board, the following checklist should be used to ensure proper operation of the IC.

- 1) Arrange the power components to reduce the AC loop size consisting of C_{IN} , IN pin, SW pin and the schottky diode.
- 2) Place input decoupling ceramic capacitor C_{IN} as close to IN pin as possible. C_{IN} is connected power GND with vias or short and wide path.
- 3) Return FB, COMP and ISET to signal GND pin, and connect the signal GND to power GND at a single point for best noise immunity.
- 4) Use copper plane for power GND for best heat dissipation and noise immunity.
- 5) Place feedback resistor close to FB pin.
- 6) Use short trace connecting HSB- C_{HSB} -SW loop

Figure 7 shows an example of PCB layout.

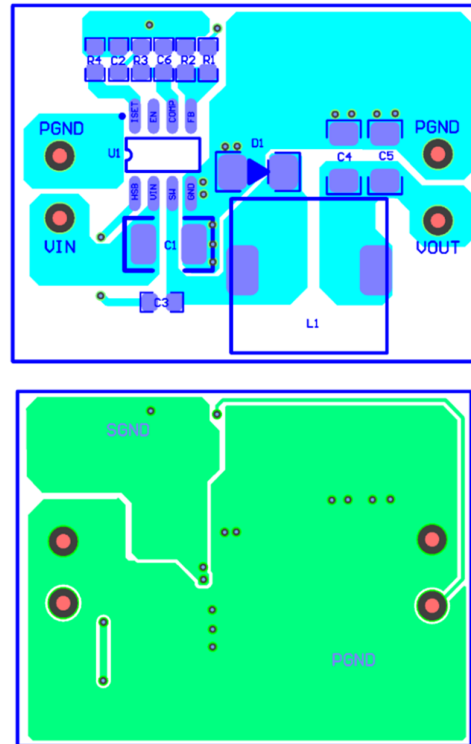

Figure 7: PCB Layout

Figure 8 and Figure 9 give two typical car charger application schematics and associated BOM list.

Figure 8:
Typical Application Circuit for 5V/1.2A Car Charger

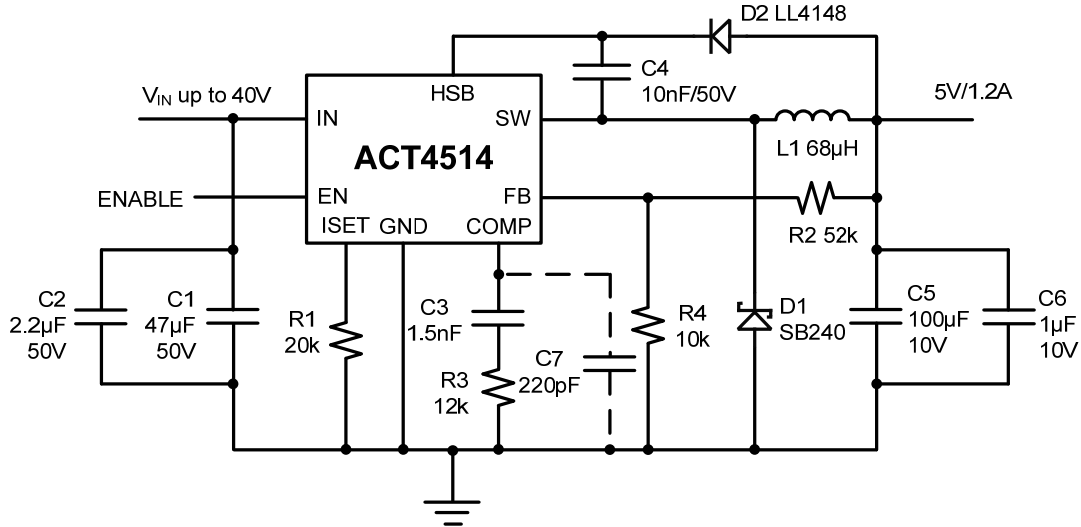

Table 2:
BOM List for 5V/1.2A Car Charger

ITEM	REFERENCE	DESCRIPTION	MANUFACTURER	QTY
1	U1	IC, ACT4514SH, SOP-8	Qorvo	1
2	C1	Capacitor, Electrolytic, 47µF/50V, 6.3x7mm	Murata, TDK	1
3	C2	Capacitor, Ceramic, 2.2µF/50V, 1206, SMD	Murata, TDK	1
4	C3	Capacitor, Ceramic, 1.5nF/6.3V, 0603, SMD	Murata, TDK	1
5	C4	Capacitor, Ceramic, 10nF/50V, 0603, SMD	Murata, TDK	1
6	C5	Capacitor, Electrolytic, 100µF/10V, 6.3x7mm	Murata, TDK	1
7	C6	Capacitor, Ceramic, 1µF/10V, 0603, SMD	Murata, TDK	1
8	C7 (Optional)	Capacitor, Ceramic, 220pF/6.3V, 0603	Murata, TDK	1
9	L1	68µH, 1.5A, 20%, SMD CDRH125-680M	Sumida	1
10	D1	Diode, Schottky, 40V/2A, SB240, DO-15	Diodes	1
11	D2	Diode, 75V/150mA, LL4148	Good-ARK	1
12	R1	Chip Resistor, 20kΩ, 0603, 1%	Murata, TDK	1
13	R2	Chip Resistor, 52kΩ, 0603, 1%	Murata, TDK	1
14	R3	Chip Resistor, 12kΩ, 0603, 5%	Murata, TDK	1
15	R4	Chip Resistor, 10kΩ, 0603, 1%	Murata, TDK	1

Figure 9:
Typical Application Circuit for 5V/0.75A Car Charger

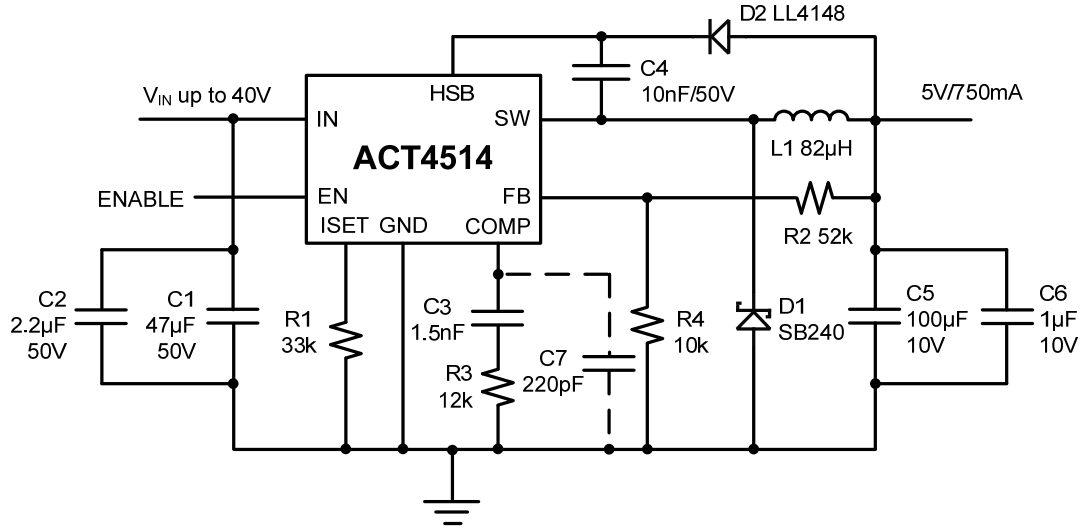
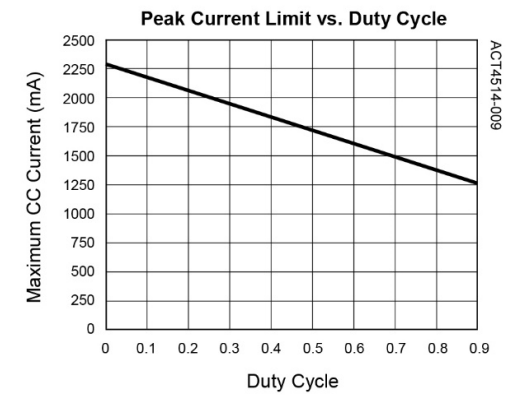
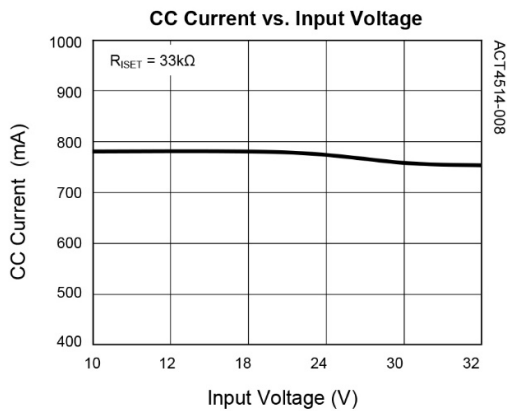
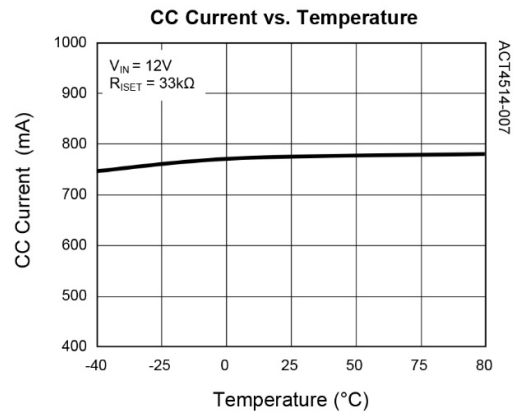
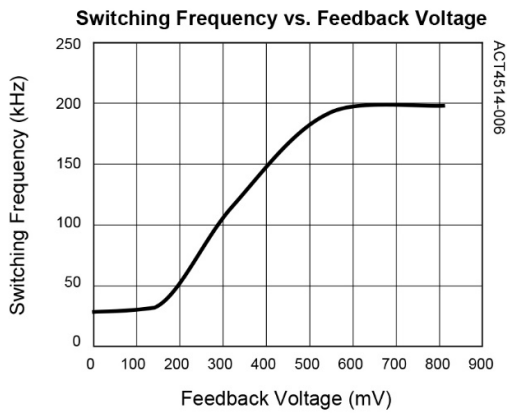
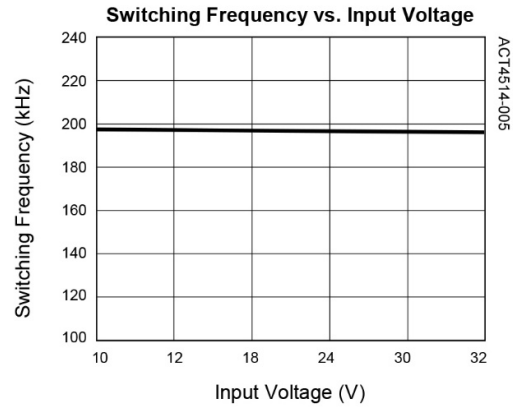
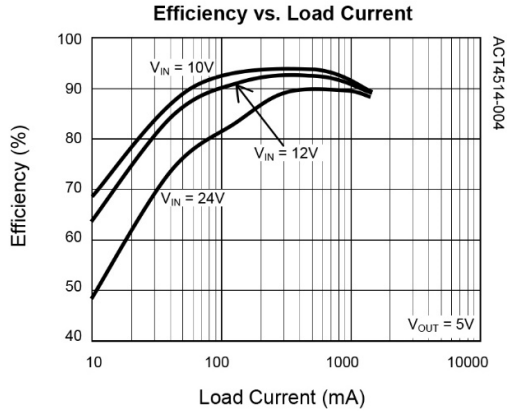

Table 3:
BOM List for 5V/0.75A Car Charger

ITEM	REFERENCE	DESCRIPTION	MANUFACTURER	QTY
1	U1	IC, ACT4514SH, SOP-8	Qorvo	1
2	C1	Capacitor, Electrolytic, 47µF/50V, 6.3x7mm	Murata, TDK	1
3	C2	Capacitor, Ceramic, 2.2µF/50V, 1206, SMD	Murata, TDK	1
4	C3	Capacitor, Ceramic, 1.5nF/6.3V, 0603, SMD	Murata, TDK	1
5	C4	Capacitor, Ceramic, 10nF/50V, 0603, SMD	Murata, TDK	1
6	C5	Capacitor, Electrolytic, 100µF/10V, 6.3x7mm	Murata, TDK	1
7	C6	Capacitor, Ceramic, 1µF/10V, 0603, SMD	Murata, TDK	1
8	C7 (Optional)	Capacitor, Ceramic, 220pF/6.3V, 0603	Murata, TDK	1
9	L1	82µH, 1A, 20%, SMD 1058-MGDN6-00013	Tyco Electronics	1
10	D1	Diode, Schottky, 40V/2A, SB240, DO-15	Diodes	1
11	D2	Diode, 75V/150mA, LL4148	Good-ARK	1
12	R1	Chip Resistor, 33kΩ, 0603, 1%	Murata, TDK	1
13	R2	Chip Resistor, 52kΩ, 0603, 1%	Murata, TDK	1
14	R3	Chip Resistor, 12kΩ, 0603, 5%	Murata, TDK	1
15	R4	Chip Resistor, 10kΩ, 0603, 1%	Murata, TDK	1

TYPICAL PERFORMANCE CHARACTERISTICS

(Circuit of Figure 7, $I_{SET} = 0.9A$, $L = 82\mu H$, $C_{IN} = 10\mu F$, $C_{OUT} = 22\mu F$, $T_A = 25^\circ C$, unless otherwise specified.)



TYPICAL PERFORMANCE CHARACTERISTICS CONT'D

(Circuit of Figure 7, $I_{SET} = 0.9A$, $L = 82\mu H$, $C_{IN} = 10\mu F$, $C_{OUT} = 22\mu F$, $T_A = 25^\circ C$, unless otherwise specified.)

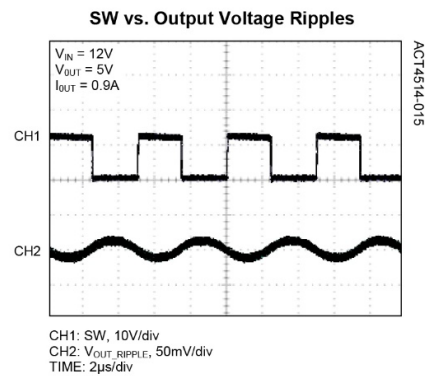
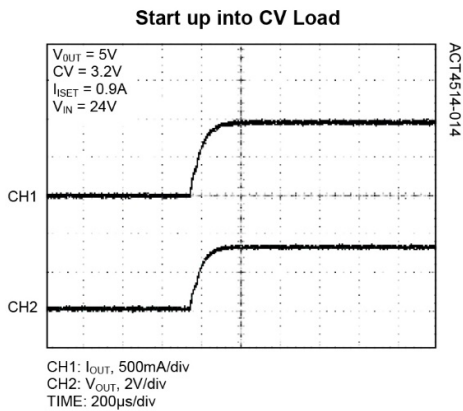
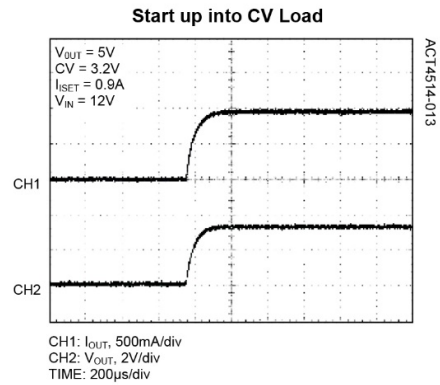
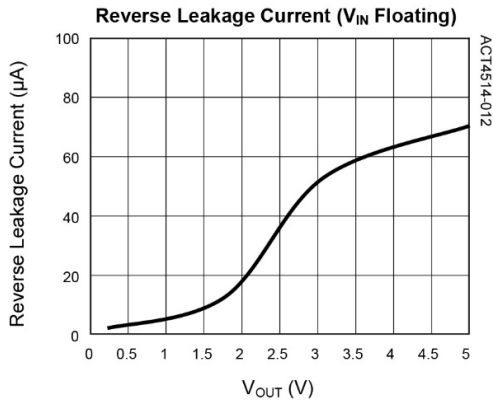
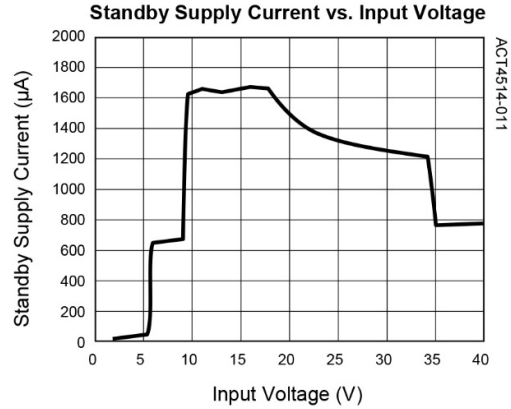
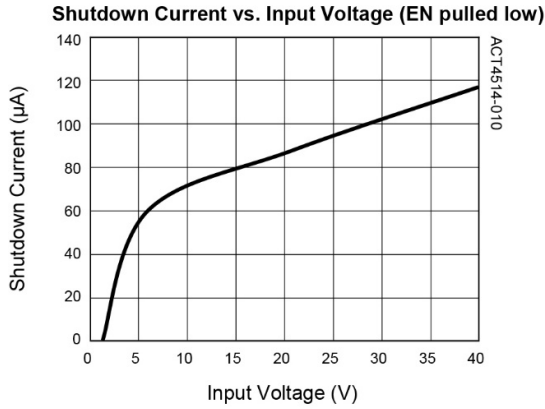

TYPICAL PERFORMANCE CHARACTERISTICS CONT'D

(Circuit of Figure 7, I_{SET} = 0.9A, L = 82μH, C_{IN} = 10μF, C_{OUT} = 22μF, T_A = 25°C, unless otherwise specified.)

SW vs. Output Voltage Ripples

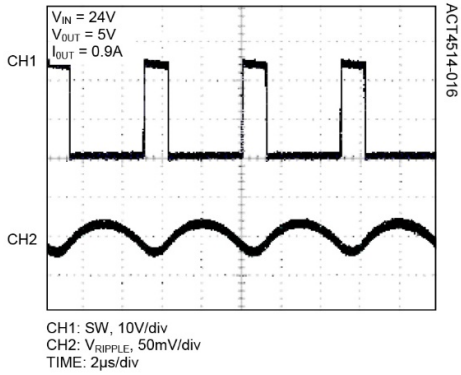

Start up with EN

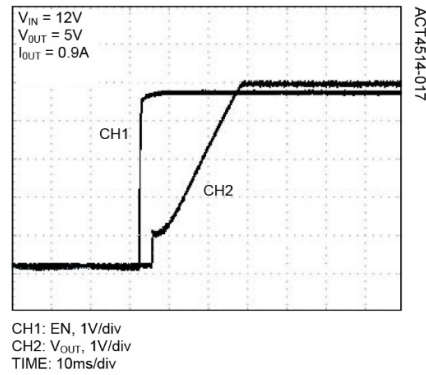

Start up with EN

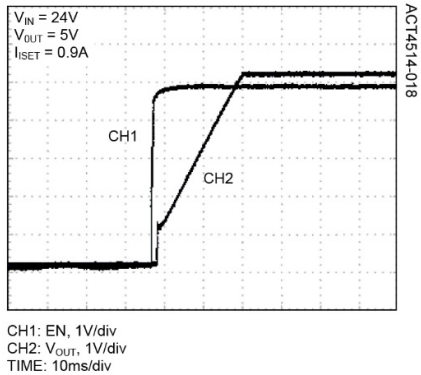

Load Step Waveforms

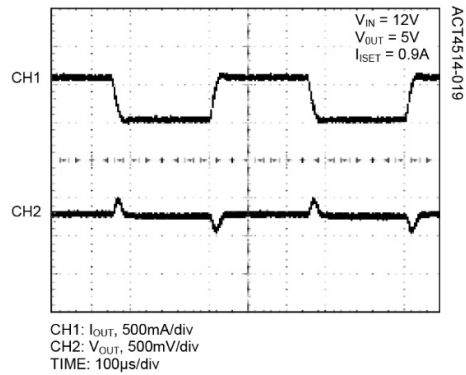

Load Step Waveforms

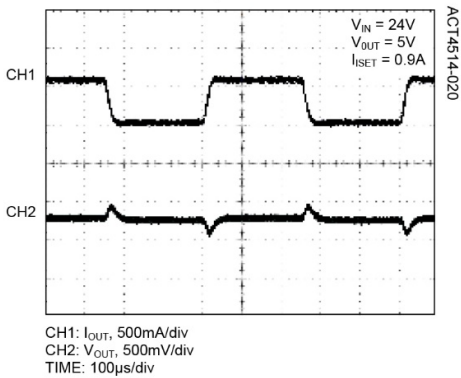

Short Circuit

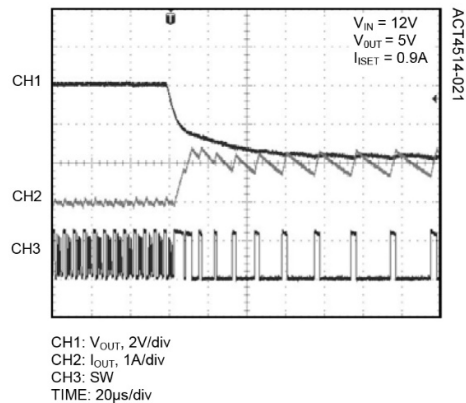

TYPICAL PERFORMANCE CHARACTERISTICS CONT'D

(Circuit of Figure 7, $I_{SET} = 0.9A$, $L = 82\mu H$, $C_{IN} = 10\mu F$, $C_{OUT} = 22\mu F$, $T_A = 25^\circ C$, unless otherwise specified.)

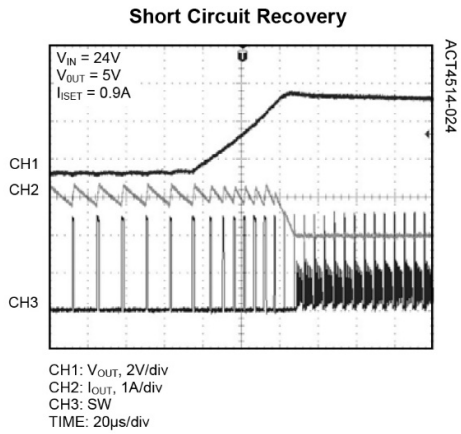
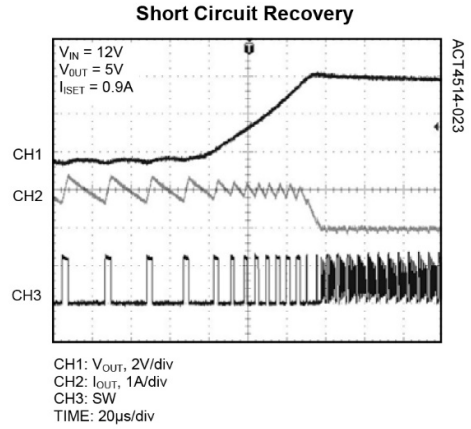
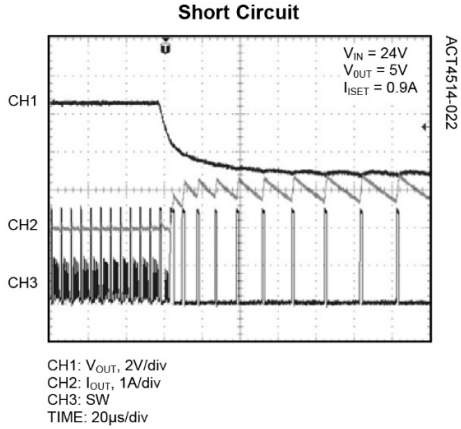

PACKAGE OUTLINE AND DIMENSIONS

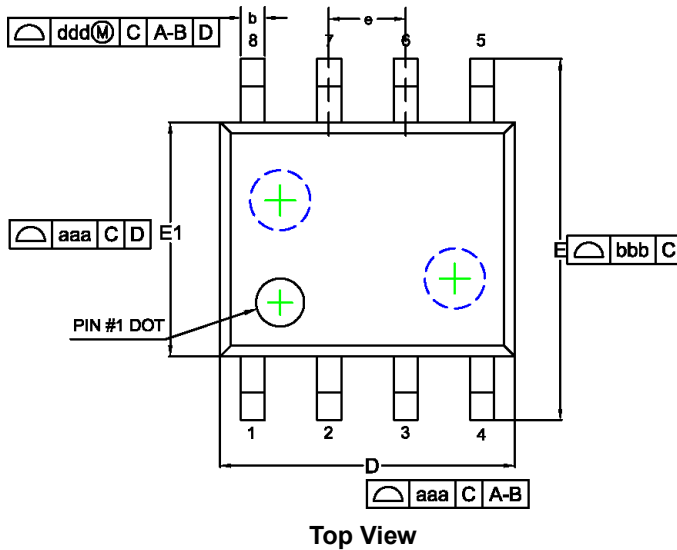

Top View

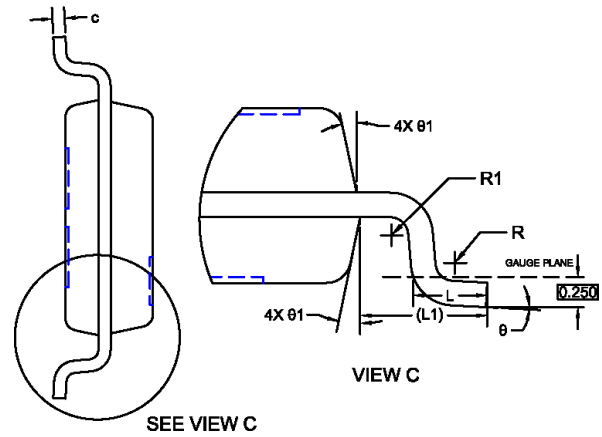

Side View

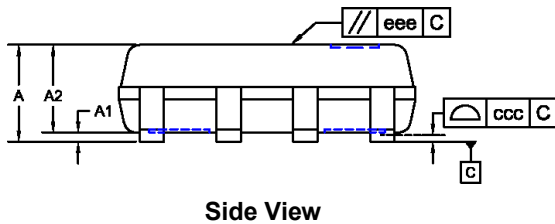

Side View

Dimensional Ref.			
REF.	Min.	Nom.	Max.
A	1.450	--	1.750
A1	0.100	--	0.250
A2	1.350	--	1.550
b	0.330	--	0.510
c	0.170	--	0.250
D	4.900BSC		
E	6.000BSC		
E1	3.900BSC		
e	1.270 BSC		
L	0.400	--	1.270
L1	1.040REF.		
R	0.070	--	--
R1	0.070	--	--
θ	0°	--	8°
$\theta 1$	5°	--	15°
Tol. of Form&Position			
aaa	0.10		
bbb	0.20		
ccc	0.10		
ddd	0.25		
eee	0.10		

Notes

1. ALL DIMENSIONS AND TOLERANCES CONFORM TO ASME Y14.5-2009.
2. ALL DIMENSIONS ARE IN MILLIMETERS.

Product Compliance

This part complies with RoHS directive 2011/65/EU as amended by (EU) 2015/863.

This part also has the following attributes:

- Lead Free
- Halogen Free (Chlorine, Bromine)



Contact Information

For the latest specifications, additional product information, worldwide sales and distribution locations:

Web: www.qorvo.com

Tel: 1-844-890-8163

Email: customer.support@qorvo.com

For technical questions and application information:

Email: appsupport@qorvo.com

Important Notice

The information contained herein is believed to be reliable; however, Qorvo makes no warranties regarding the information contained herein and assumes no responsibility or liability whatsoever for the use of the information contained herein. All information contained herein is subject to change without notice. Customers should obtain and verify the latest relevant information before placing orders for Qorvo products. The information contained herein or any use of such information does not grant, explicitly or implicitly, to any party any patent rights, licenses, or any other intellectual property rights, whether with regard to such information itself or anything described by such information. **THIS INFORMATION DOES NOT CONSTITUTE A WARRANTY WITH RESPECT TO THE PRODUCTS DESCRIBED HEREIN, AND QORVO HEREBY DISCLAIMS ANY AND ALL WARRANTIES WITH RESPECT TO SUCH PRODUCTS WHETHER EXPRESS OR IMPLIED BY LAW, COURSE OF DEALING, COURSE OF PERFORMANCE, USAGE OF TRADE OR OTHERWISE, INCLUDING THE IMPLIED WARRANTIES OF MERCHANTABILITY AND FITNESS FOR A PARTICULAR PURPOSE.**

Without limiting the generality of the foregoing, Qorvo products are not warranted or authorized for use as critical components in medical, life-saving, or life-sustaining applications, or other applications where a failure would reasonably be expected to cause severe personal injury or death.

Copyright 2019 © Qorvo, Inc. | Qorvo® and Active-Semi® are trademarks of Qorvo, Inc.

X-ON Electronics

Largest Supplier of Electrical and Electronic Components

Click to view similar products for [Switching Voltage Regulators](#) category:

Click to view products by [Active-Semi manufacturer](#):

Other Similar products are found below :

[FAN53610AUC33X](#) [FAN53611AUC123X](#) [FAN48610BUC33X](#) [FAN48610BUC45X](#) [FAN48617UC50X](#) [R3](#) [430464BB](#) [KE177614](#)
[FAN53611AUC12X](#) [MAX809TTR](#) [NCV891234MW50R2G](#) [NCP81103MNTXG](#) [NCP81203PMNTXG](#) [NCP81208MNTXG](#)
[NCP81109GMNTXG](#) [SCY1751FCCT1G](#) [NCP81109JMNTXG](#) [AP3409ADNTR-G1](#) [NCP81241MNTXG](#) [LTM8064IY](#) [LT8315EFE#TRPBF](#)
[LTM4664EY#PBF](#) [LTM4668AIY#PBF](#) [NCV1077CSTBT3G](#) [XCL207A123CR-G](#) [MPM54304GMN-0002](#) [MPM54304GMN-0004](#)
[MPM54304GMN-0003](#) [AP62300Z6-7](#) [MP8757GL-P](#) [MIC23356YFT-TR](#) [LD8116CGL](#) [HG2269M/TR](#) [OB2269](#) [XD3526](#) [U6215A](#) [U6215B](#)
[U6620S](#) [LTC3412IFE](#) [LT1425IS](#) [MAX25203BATJA/VY+](#) [MAX77874CEWM+](#) [XC9236D08CER-G](#) [MP3416GJ-P](#) [BD9S201NUX-CE2](#)
[MP5461GC-Z](#) [MPQ4415AGQB-Z](#) [MPQ4590GS-Z](#) [MAX38640BENT18+T](#) [MAX77511AEWB+](#)