

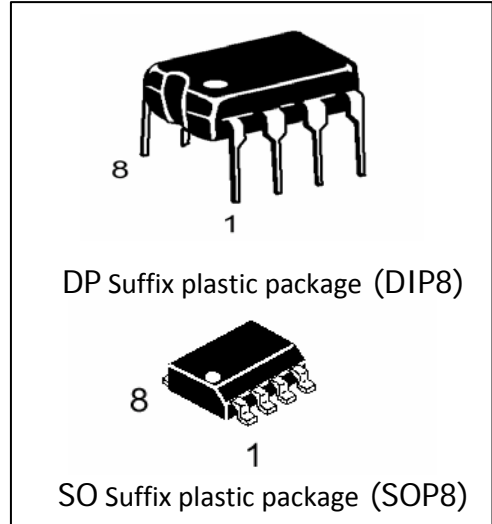

Features:

- Low quiescent current;
- Wide supply voltage range: 2.5V-12V;
- 800mA continuous current output capability per channel;
- Lower saturation voltage;
- TTL / CMOS output level compatible, and can be directly connected to the CPU;
- Output built-in clamp diodes for inductive load;
- Integrated control and drive into a monolithic IC;
- With pin high-voltage protection function;
- Operating temperature: 0 °C -80 °C.



Description :

L9110 The ASIC device control and drive motor design two-channel push-pull power amplifier discrete circuits integrated into a monolithic IC, peripheral devices and reduce the cost, improve the reliability of the whole. This chip has two TTL / CMOS compatible with the level of the input, with good resistance; two output terminals can directly forward and reverse movement of the drive motor, it has a large current driving capability, each channel through 750 ~ 800mA of continuous current, peak current capability up to 1.5 ~

2.0A; while it has a low output saturation voltage; **built-in clamp diode reverse the impact of the current** release inductive load it in the drive relays, DC motors, stepper motor or switch power tube use on safe and reliable. L9110 is widely used in toy car motor drives, stepper motor drive and switching power tube circuit.

Pin definitions:

No.	Symbol	Function
1	OA	A road output pin
2	VCC	Supply Voltage
3	VCC	Supply Voltage
4	OB	B output pin
5	GND	Ground
6	IA	A road input pin
7	IB	B input pin
8	GND	Ground

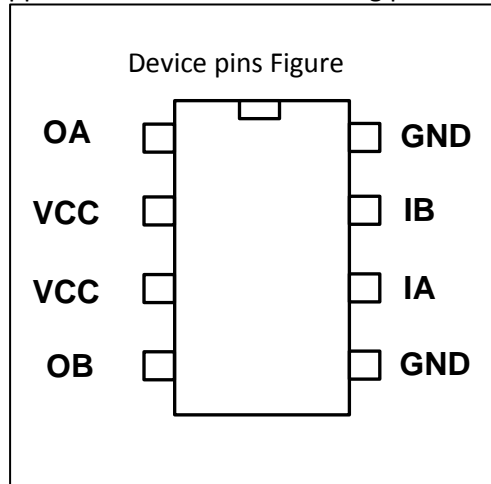

Test conditions: Vcc =9V , Iout =750mA

Symbol	Parameters	minimum	Typical	maximum	units
VH _{out}	Output high	7.50	7.60	7.70	V
VL _{out}	Output low	0.35	0.45	0.55	V
VH _{in}	Input high	2.5	5.0	9.0	V
VL _{in}	Input low	0	0.5	0.7	V





Electrical characteristics:

Logical relationship:

Symbol	Parameters	Range			Units
		Min	Typical	Max	
VCC	Supply Voltage	2.5	6	12	V
I _{dd}	Quiescent Current	—	0	2	uA
I _{in}	Operating current	200	350	500	uA
I _C	Continuous	750	800	850	mA
I _{Max}	Current peak	—	1500	2000	mA

IA	IB	OA	OB
H	L	H	L
L	H	L	H
L	L	L	L
H	H	L	L

Pin waveform diagram:

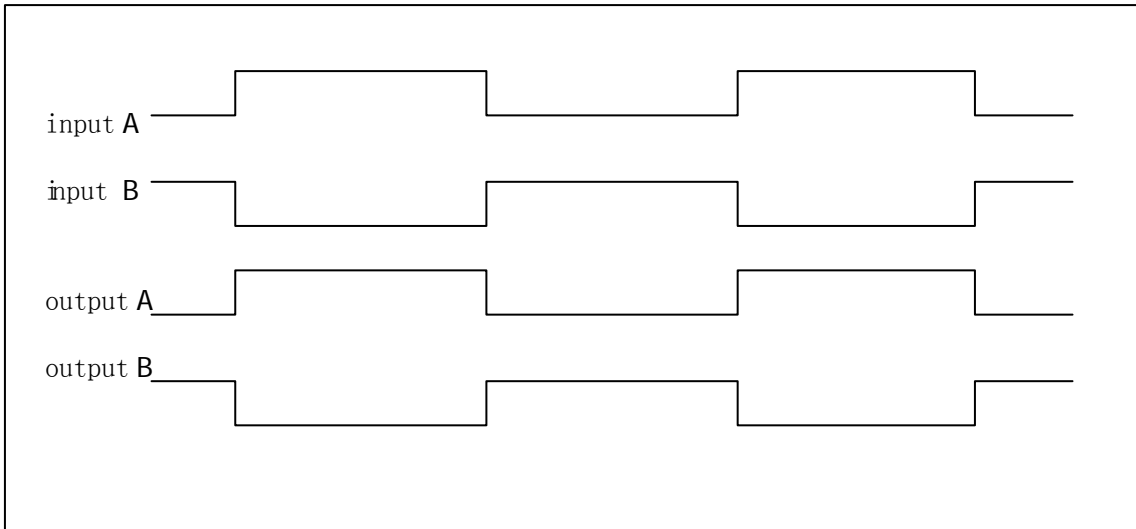

Application Circuit:

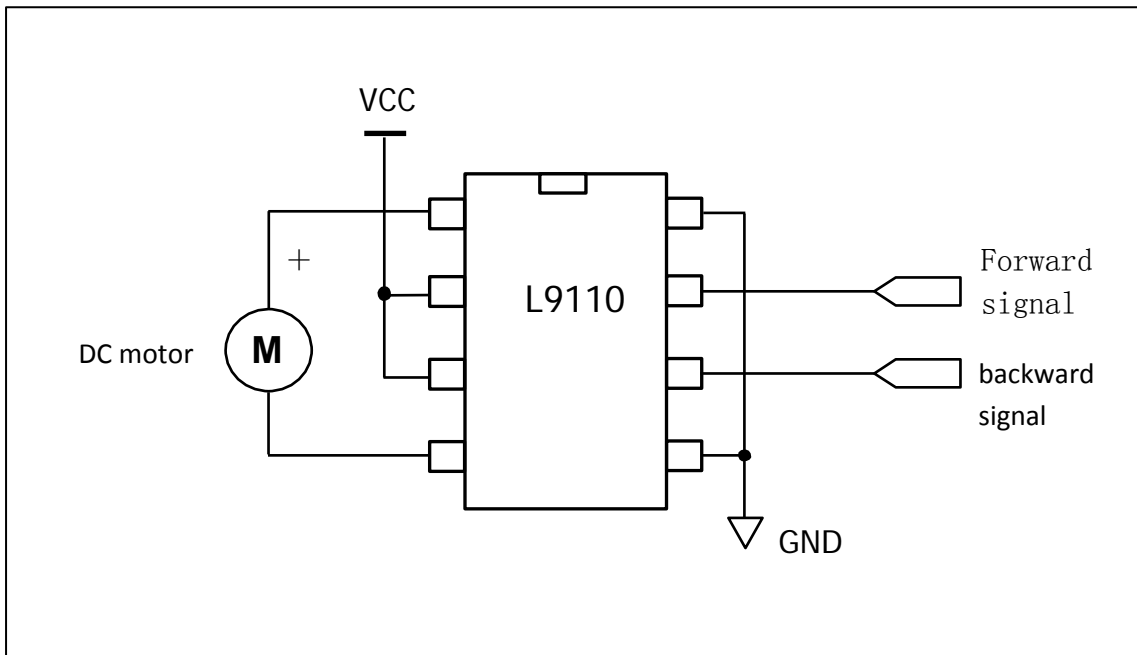

X-ON Electronics

Largest Supplier of Electrical and Electronic Components

Click to view similar products for [Motor/Motion/Ignition Controllers & Drivers](#) category:

Click to view products by [Adafruit](#) manufacturer:

Other Similar products are found below :

[FSB50550TB2](#) [FSBF15CH60BTH](#) [MSVCPM2-63-12](#) [MSVGW45-14-2](#) [MSVGW54-14-3](#) [MSVGW54-14-5](#) [NTE7043](#) [LA6565VR-TLM-E](#)
[LB11650-E](#) [LB1837M-TLM-E](#) [LB1845DAZ-XE](#) [LC898300XA-MH](#) [SS30-TE-L-E](#) [26700](#) [LV8281VR-TLM-H](#) [BA5839FP-E2](#) [IRAM236-1067A](#) [LA6584JA-AH](#) [LB11847L-E](#) [NCV70501DW002R2G](#) [AH293-PL-B](#) [TND315S-TL-2H](#) [FNA23060](#) [FSB50250AB](#) [FNA41060](#)
[MSVB54](#) [MSVBTC50E](#) [MSVCPM3-54-12](#) [MSVCPM3-63-12](#) [MSVCPM4-63-12](#) [MSVTA120](#) [FSB50550AB](#) [NCV70501DW002G](#)
[LC898301XA-MH](#) [LV8413GP-TE-L-E](#) [MSVGW45-14-3](#) [MSVGW45-14-4](#) [MSVGW45-14-5](#) [MSVGW54-14-4](#) [STK984-091A-E](#)
[SLA7026M](#) [MP6519GQ-Z](#) [LB11651-E](#) [IRSM515-025DA4](#) [LV8127T-TLM-H](#) [MC33812EKR2](#) [NCP81382MNTXG](#) [TDA21801](#)
[LB11851FA-BH](#) [NCV70627DQ001R2G](#)