

Express-BASE6

COM Express® Type 6 Reference Carrier Board in ATX Form Factor

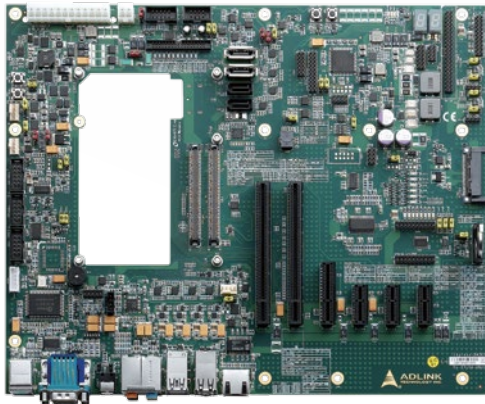

Features

- One PCI Express x4 slot, three PCI Express x1 slots
- PCI Express x16 / SDVO slot
- Supports three Digital Display Interfaces (DDI) with HDMI/DVI/DisplayPort output
- LPC based Super I/O
- Dual BIOS (SPI and LPC)
- Conforms to COM Express® Carrier Design Guide

Specifications

Form Factor

Core Module Interface	PICMG® COM Express® Revision 2.0
Dimensions	Supports Type 6 modules in Basic or Compact form factor 305 mm x 244 mm (ATX)
Expansion Busses	One PCI Express x4 slot, three PCI Express x1 slots One ExpressCard slot One PCI Express x16 / SDVO slot

BIOS / Debug

POST LEDs	Onboard diagnostics for BIOS POST code data and address on LPC bus
Secondary BIOS	Onboard socket for secondary SPI flash

Active Components

Audio	Realtek ALC886 High Definition Audio Codec
Super I/O	Winbond WF83627DHG on LPC bus
Digital I/O	I ² C to GPIO bridge PCA9535

Connectors

COM Express®	Two x 220-pin (Type 6)
VGA	DB15 on Rear I/O panel for VGA display
LVDS	Onboard 34-pin header
Digital Display Interface	Supports three DDI ports to HDMI/DVI/DisplayPort output by adapter card (PCIe x16 slot with proprietary pinout)
Flat Panel Control	Onboard 8-pin header
Audio	Mic/Line-in/Line-out on I/O panel
SATA	Two SATA ports (SATA0/1), two eSATA ports (SATA2/3)
ExpressCard	One socket onboard
LAN	10/100/1000BASE-T compatible RJ45 on I/O panel
USB 2.0	Four USB 2.0 on I/O panel, Four USB 2.0/3.0 on I/O panel
Serial Port	One DB-9 on I/O panel One onboard 10-pin header
Smart Battery	One 10-pin header for Smart Battery management communications (connects to ADLINK BattMan board)
LPC Debug	Onboard 20-pin header
KB/Mouse	Two 6-pin mini DIN (on rear I/O panel)
Feature Connectors	SMBus, I ² C, module control signals
Miscellaneous	Reset, Power LED, HDD LED, Buzzer

Functional Diagram

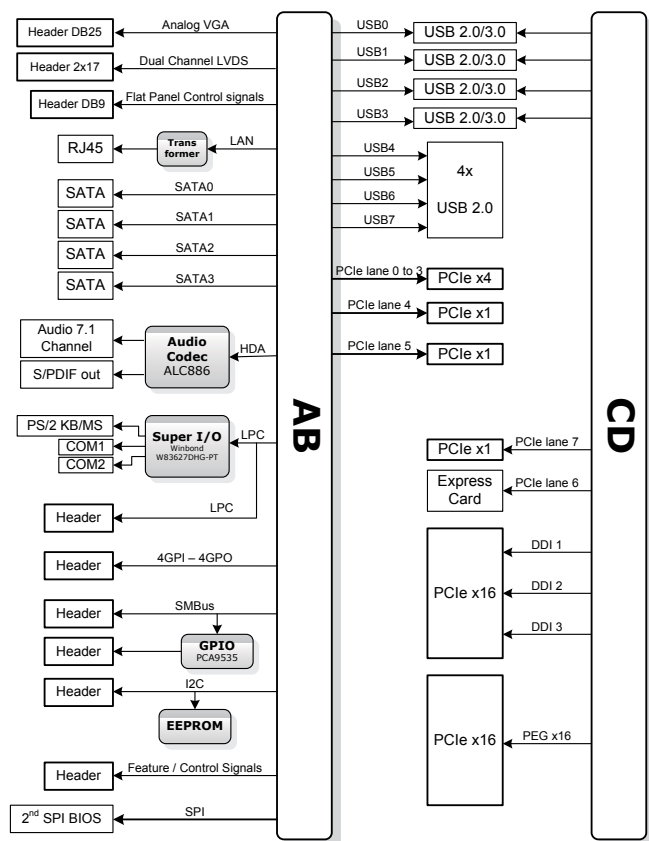

Ordering Information

Modules

Model Number	Description/Configuration
Express-BASE6	COM Express® Type 6 Reference Carrier Board in ATX form factor

COM Express Carrier Design Guide **COM** **Express**

Provides detailed information on designing your own custom carrier board for COM Express modules.

Note: All specifications are subject to change without further notice.

X-ON Electronics

Largest Supplier of Electrical and Electronic Components

Click to view similar products for [Development Boards & Kits - x86 category](#):

Click to view products by [ADLINK Technology manufacturer](#):

Other Similar products are found below :

[conga-MEVAL](#) [iQ7-DB-MATX-R10](#) [DFR0453](#) [ETX-Proto](#) [Q7-BASE-R01](#) [Starterkit-CFE-E-2176M-3DIMM/M48G](#) [Starterkit-COM Express](#)
[6](#) [Starterkit-COM Express 6 PLUS](#) [VIZI-AI LEC-AL-E3940-AI-4G-32G/EMEA](#) [VPX-R300](#) [AKX00002](#) [AKX00002SL](#) [CEB94701](#) [7000-](#)
[54864-102-101](#) [ARDUINO2.AL.B](#) [ARDUINO.AL.B](#) [GT.PDKW](#) [IOTGTWY.DK110](#) [IOTGTWY.DK200](#) [IOTGTWY.DK300](#)
[IOTGTWY.DK50](#) [MIKROE-2582](#) [102010028](#) [110060064](#) [110060382](#) [110060577](#) [SOM-DB5800-00A2E](#) [ROM-DB7500-SCA1E](#) [conga-](#)
[QEVAL/Qseven 2.0](#) [conga-QKIT](#) [X7EVAL/ind](#) [68300-0000-00-0](#) [MIKROE-2546](#) [DEV-13033](#)