

1-Ch Differential Sensitivity Capacitive Touch Sensor

SPECIFICATION V1.2

작성	검토	PL	App.	Marketing	QA	Approval

■ Revision History

Rev.	Description of change	Date	Originator
1.0	Initial Release	10. 05. 12.	KD PARK
1.1	AD Logo changed The POD changed	12. 11. 30.	KD PARK
1.2	Modify operating temperature spec. Add year code(2017-2026)	17. 02. 10	HS KWAK

AWS01 (1-CH Differential Sensitivity Capacitive Touch Sensor)

1 Specification

1.1 General features

- 1-Channel capacitive touch sensor with differential sensitivity calibration
- Low power consumption
- Open-drain digital output
- Internal power on reset
- Embedded common and normal noise elimination circuit
- RoHS compliant SOT-26 package

1.2 Application

- Home appliance
- Mobile phone hall sensor replacement
- Fluid level sensing
- Switch replacement
- Membrane switch replacement
- Human interface for toys & interactive games
- Sealed control panels, keypads
- Seat sensor for a bidet

1.3 Package (SOT-26)

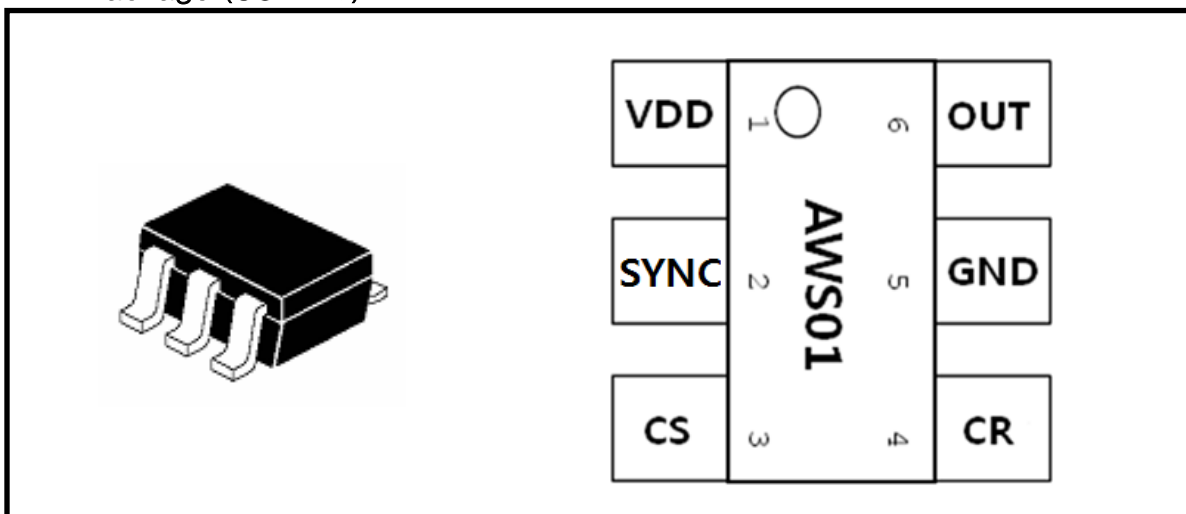

AWS01 SOT-26 (Drawings not to scale)

AWS01 (1-CH Differential Sensitivity Capacitive Touch Sensor)

2 Pin Description (SOT-26)

PIN Number	Name	I/O	Description	Protection
1	VDD	Power	Power (2.5V ~ 5.0V)	GND
2	SYNC	Analog Input /Output	Adjust the response time	VDD/GND
3	CS	Analog Input	Capacitive sensor input	VDD/GND
4	CR	Analog Input	Reference sensor input for differential sensitivity calibration and initial touch detect	VDD/GND
5	GND	Ground	Supply ground	VDD
6	OUT	Digital Output	Touch detect out	VDD/GND

3 Absolute Maximum Rating

Supply voltage	5.5 V
Maximum voltage on any pin	VDD+0.3 V
Maximum current on any PAD	100mA
Continuous power Dissipation	200mW
Storage Temperature	-50 ~ 150°C
Operating Temperature	-40 ~ 85°C
Junction Temperature	150°C

Note1 : Unless any other command is noted, all above are operated in normal temperature.

4 ESD & Latch-up Characteristics

4.1 ESD characteristics

Mode	Polarity	Minimum Level	Reference
H.B.M	Pos / Neg	3000V	VDD
		3000V	VSS
		3000V	P to P
M.M	Pos / Neg	300V	VDD
		300V	VSS
		300V	P to P
C.D.M	Pos / Neg	1000V	DIRECT

4.2 Latch-up characteristics

Mode	Polarity	Minimum Level	Test Step
I Test	Positive	25mA ~ 100mA	25mA
	Negative	-25mA ~ -100mA	
V supply over 5.0V	Positive	18V	1V

AWS01 (1-CH Differential Sensitivity Capacitive Touch Sensor)

5 Electrical Characteristics

▪ $V_{DD}=3.3V$ (Unless otherwise noted), $T_A = 25^\circ C$

Characteristics	Symbol	Test Condition	Min	Typ	Max	Units
Operating supply voltage	V_{DD}		2.5	3.3	5.0	V
Current consumption	I_{DD}	$V_{DD}= 3.3V$	-	230	-	μA
		$V_{DD}= 5.0V$	-	285	-	
Output maximum sink current	I_{OUT}	$T_A = 25^\circ C$	-	-	4.0	mA
Internal reset V_{DD} voltage	V_{DD_RST}	$T_A = 25^\circ C$	-	1.9	2.1	V
Sense input capacitance range [Note2]	C_S		-	10	100	pF
Reference input capacitance range	C_R		-	12	100	
Sense input resistance range	R_S		-	200	1000	Ω
Minimum detectable capacitance variation	ΔC_S	$C_S = 10pF$	0.2	-	-	pF
Output impedance (open drain)	Z_o	$\Delta C_S > 0.2pF$	-	12	-	Ω
		$\Delta C_S < 0.2pF$	-	30M	-	
Maximum supply voltage rising time	T_{R_VDD}		-	-	100	ms

Note 2: The sensitivity can be increased with lower C_S value.

The recommended value of C_S is 10pF when using 3T PC(Poly Carbonate) cover and 10 mm x 7 mm touch pattern and middle sensitivity selection.

6 AWS01 Implementation

6.1 Current consumption

AWS01 uses internal bias circuit, so internal clock frequency and current consumption is not adjusted. The typical current consumption curve of AWS01 is represented in accordance with V_{DD} voltage as below. The higher V_{DD} requires more current consumption.

Internal bias circuit can make the circuit design simple and reduce external components.

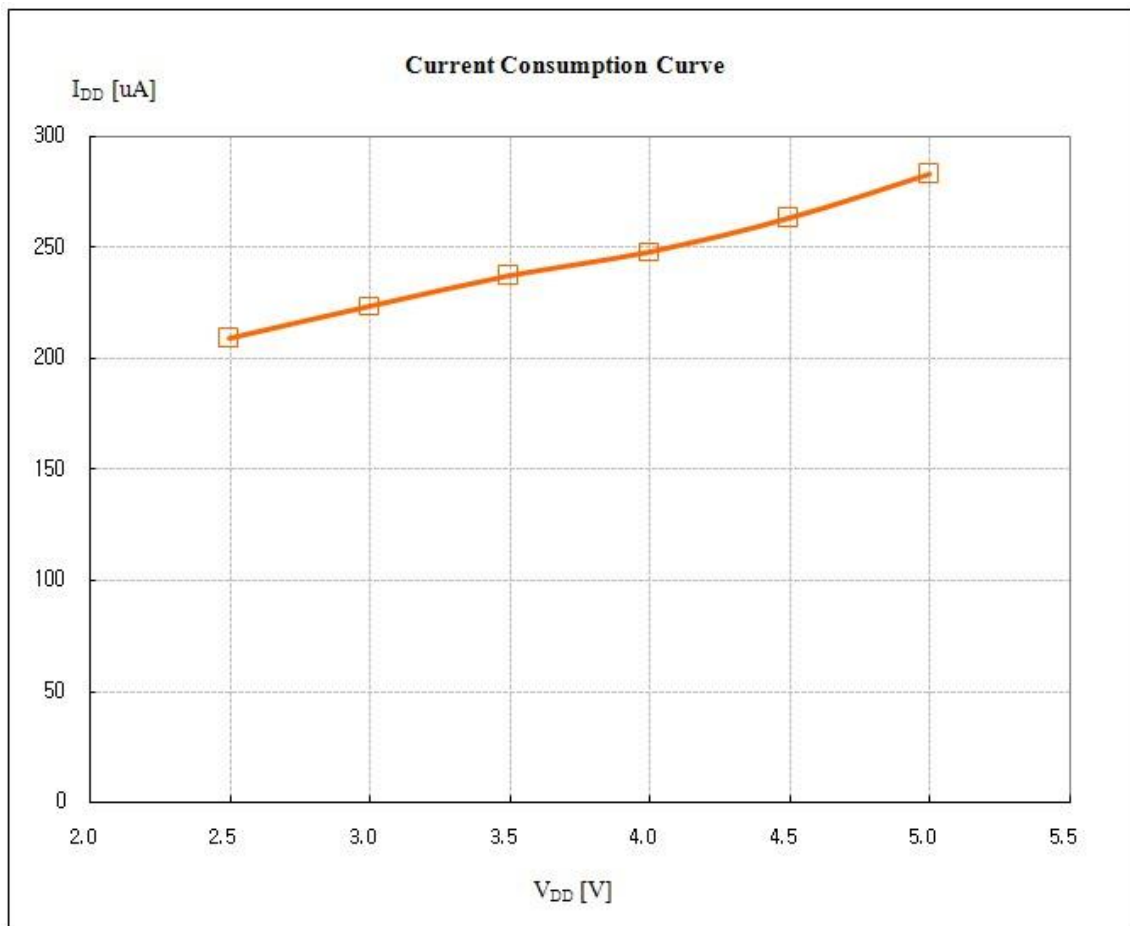

Typical current consumption curve of AWS01

AWS01 (1-CH Differential Sensitivity Capacitive Touch Sensor)

6.2 CS and CR implementation

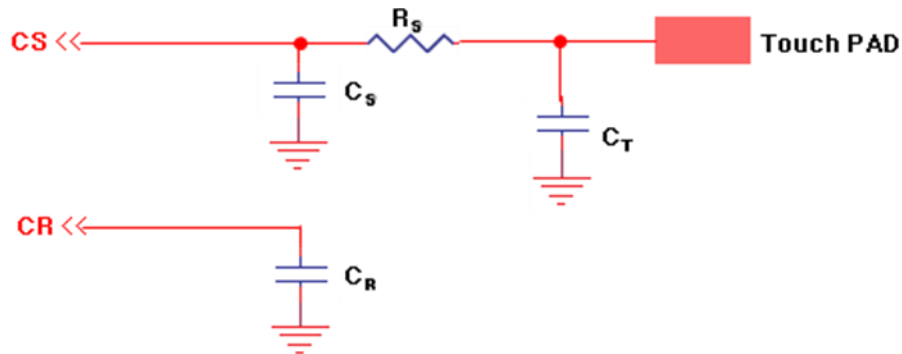

The parallel capacitor C_S is added to CS and C_R to CR to adjust fine sensitivity. The major factor of the sensitivity is C_S . The sensitivity would be increased when smaller C_S value is used. In addition, the closer capacitance of C_R is to the capacitance of C_{S_TOT} , the higher AWS01 can get sensitivity. The total C_R value must be between C_{S_TOT} and ΔC_{S_TOT} ($\Delta C_{S_TOT} = C_{S_TOT} + C_T$, the C_T is added to the C_{S_TOT} when user touches the Touch PAD.) for touch operation (Refer to the below figure). The total CS capacitance is composed of C_S which is set for optimal sensitivity and parasitic capacitance of CS pattern (C_{PARA}). The parasitic capacitance of CS pattern is about 2pF if normal touch pattern size is used. But in the case of using larger touch pattern, C_{PARA} is bigger than normal value.

The R_S is serial connection resistor to avoid malfunction from external surge and ESD. (It might be optional.) From 200 Ω to 1k Ω is recommended for R_S . The size and shape of touch PAD might have influence on the sensitivity. The sensitivity will be optimal when the size of PAD is approximately an half of the first knuckle (it's about 10 mm x 7 mm). The connection line of CS to the touch PAD is recommended to be routed as short as possible to prevent from abnormal touch detection caused by connection line.

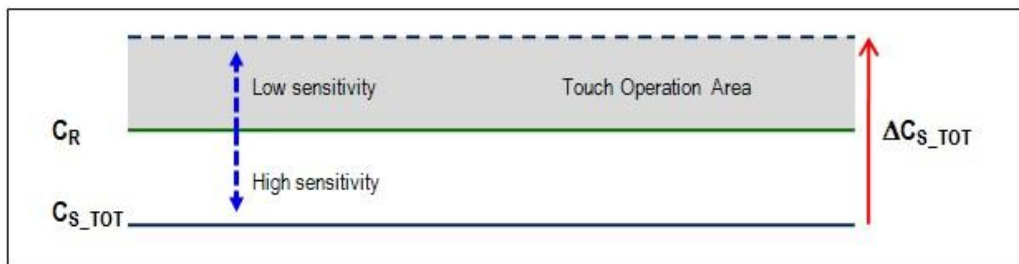

Sensitivity example figure of AWS01

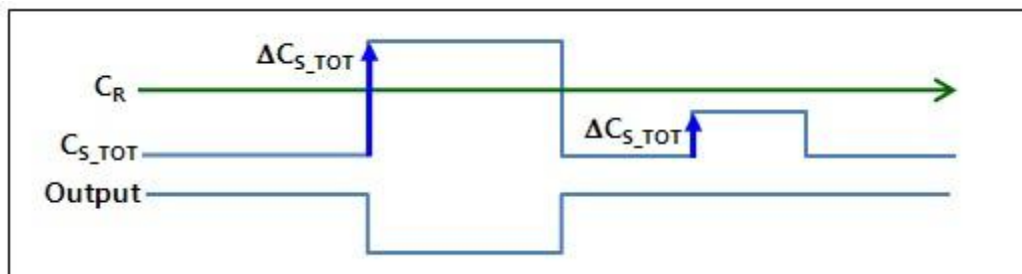

Operation example figure of AWS01

AWS01 (1-CH Differential Sensitivity Capacitive Touch Sensor)

6.3 SYNC implementation



From two AWS01 to ten AWS01 (or other TS series touch sensor) can work on the one application at the same time thanks to SYNC function with this pin. The SYNC pulse prevents over two sensing signal from interfering with each other. During the sense disable period and SYNC input becomes high, internal clock is suspended. The R_{SYNC} is pull-down resistor of SYNC pin. Too big value of R_{SYNC} makes the SYNC pulse falling delay, and too small value of R_{SYNC} makes rising delay. The typical value of R_{SYNC} is $2M\Omega$.

6.4 SYNC implementation for response time control.

Another function of SYNC pin of AWS01 is the response time control without any additional external component. The SYNC implementation for response time control is informed as below chart. And slow response time is recommended in noisy environment.

SYNC Connection	R_{SYNC} Connection or Open	Connected to VDD	Connected to GND
Response time	Slow	-	Normal

6.5 OUTPUT implementation

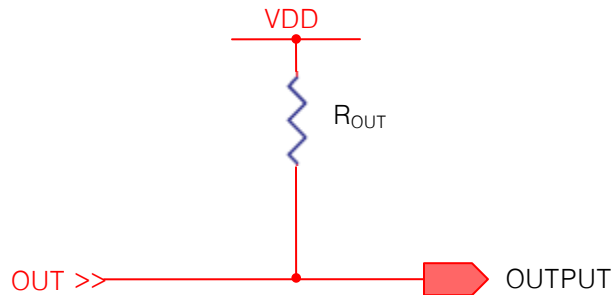

The OUT is an open drain structure. For this reason, the connection of pull-up resistor R_{OUT} is required between OUT and V_{DD} or another lower voltage node. When R_{OUT} is connected to higher voltage node than V_{DD} , the output current passes through protection diode to V_{DD} and abnormal operation may be occurred.

The maximum output sink current is 4mA, so over a few $k\Omega$ must be used as R_{OUT} . Normally 10k Ω is used as R_{OUT} . The OUT is high in normal situation, and the value is low when a touch is detected on CS .

6.6 Internal reset operation

The AWS01 has stable internal reset circuit that offers reset pulse to digital block. The supply voltage for a system start or restart should be under $0.3 \cdot V_{DD}$ of normal operation V_{DD} . No external components required for AWS01 power reset, thus it helps simple circuit design and minimize the cost of application.

⚠ CAUTION: The V_{DD} rising time should be less than 100ms for proper power on reset.

7 Recommended Circuit Diagram

7.1 Application Example

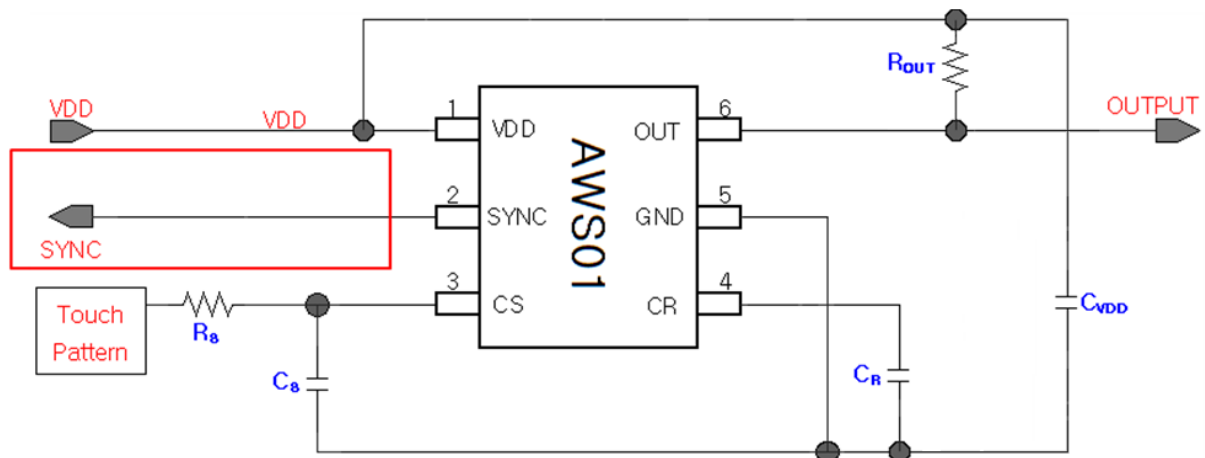

- ✦ The capacitor and resistor might be connected with CS (pin3) for getting a stable sensitivity.
- ✦ The capacitor value which is connected to CR pin (C_R) should be little bigger than the total CS capacitance (include parasitic capacitance) for touch operation.
- ✦ AWS01 is reset by internal reset circuit. VDD voltage rising time should be shorter than 100msec for proper operation.
- ✦ The sensitivity can be adjusted the total CS capacitance and the difference the total CS capacitance and the C_R value (Refer to chapter 6.2).
- ✦ From two AWS01 to ten AWS01 (or other TS series touch sensor) can work on the one application at the same time thanks to SYNC function. (Refer to chapter 6.3)
- ✦ AWS01 OUT port has an open drain structure. The pull-up resistor should therefore be needed as above figure.
- ✦ VDD periodic voltage ripples over 50mV or the ripple frequency which is lower than 10 kHz it can cause wrong operation. To prevent above problem, power (VDD, GND) line of touch circuit should be separated from the other circuit. Especially the LED driver power line or digital switching circuit power line should be certainly treated to be separated from touch circuit.
- ✦ The C_s pattern should be routed as short as possible and the width of the line should be around 0.25mm.
- ✦ The C_s pattern routing should be formed by bottom metal (opposite metal of touch PAD).
- ✦ The capacitor which is between VDD and GND is an obligation. It should be placed as close as possible from AWS01.
- ✦ The empty space of PCB must be filled with GND pattern to strengthen GND pattern and to prevent external noise that causes interference with the sensing frequency.

AWS01 (1-CH Differential Sensitivity Capacitive Touch Sensor)

7.2 Example – Power Line Split Strategy

A. Not split power line (Bad power line design)

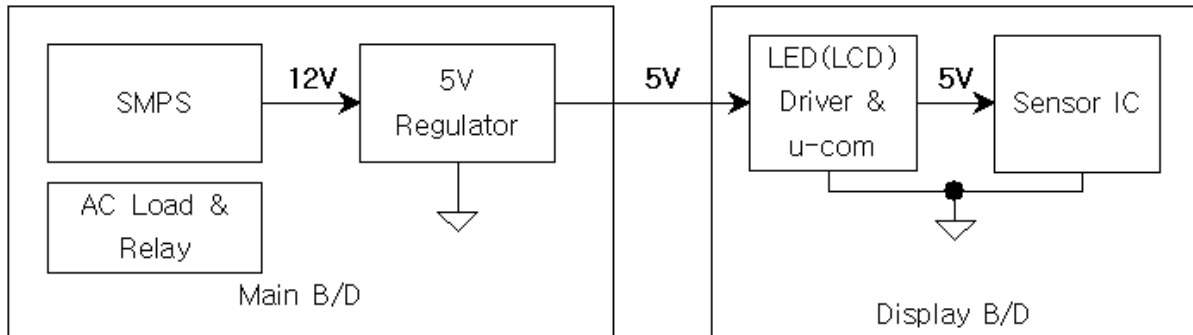

- ✦ The noise that is generated by AC load or relay can be loaded at VDD power line.
- ✦ A big inductance might be appeared in case of the connection line between main board and display board is too long, moreover the voltage ripple could be generated by LED (LCD) display driver at VDD.

B. Split power line (One 5V regulator used) – Recommended

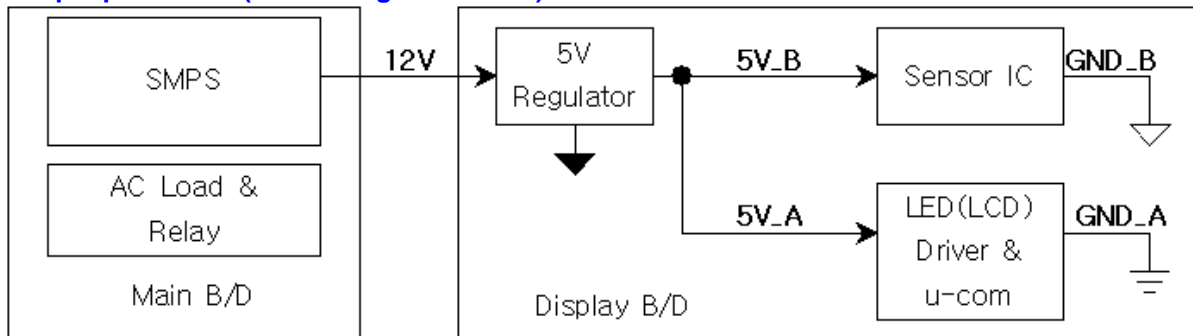

C. Split power line (Separated 5V regulator used) – Strongly recommended

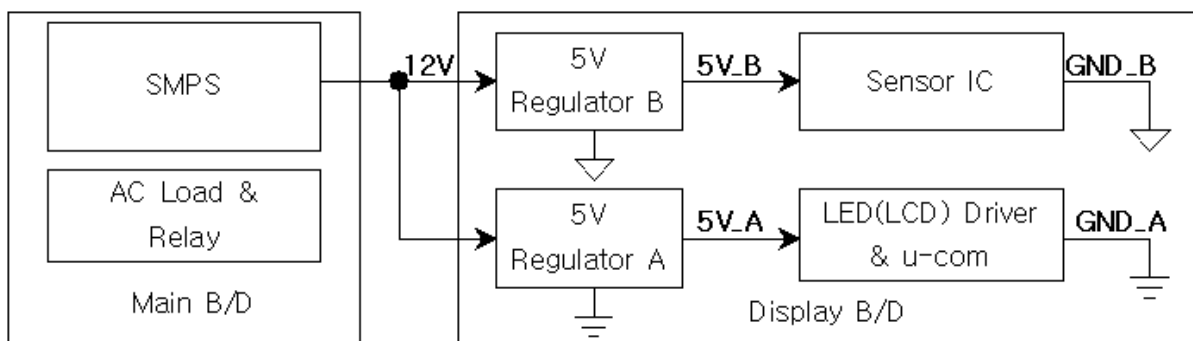

ADSemiconductor®

" Free from Common Mode Noise "

AWS01 (1-CH Differential Sensitivity Capacitive Touch Sensor)

8 PACKAGE DESCRIPTION

8.1 Mechanical Drawing

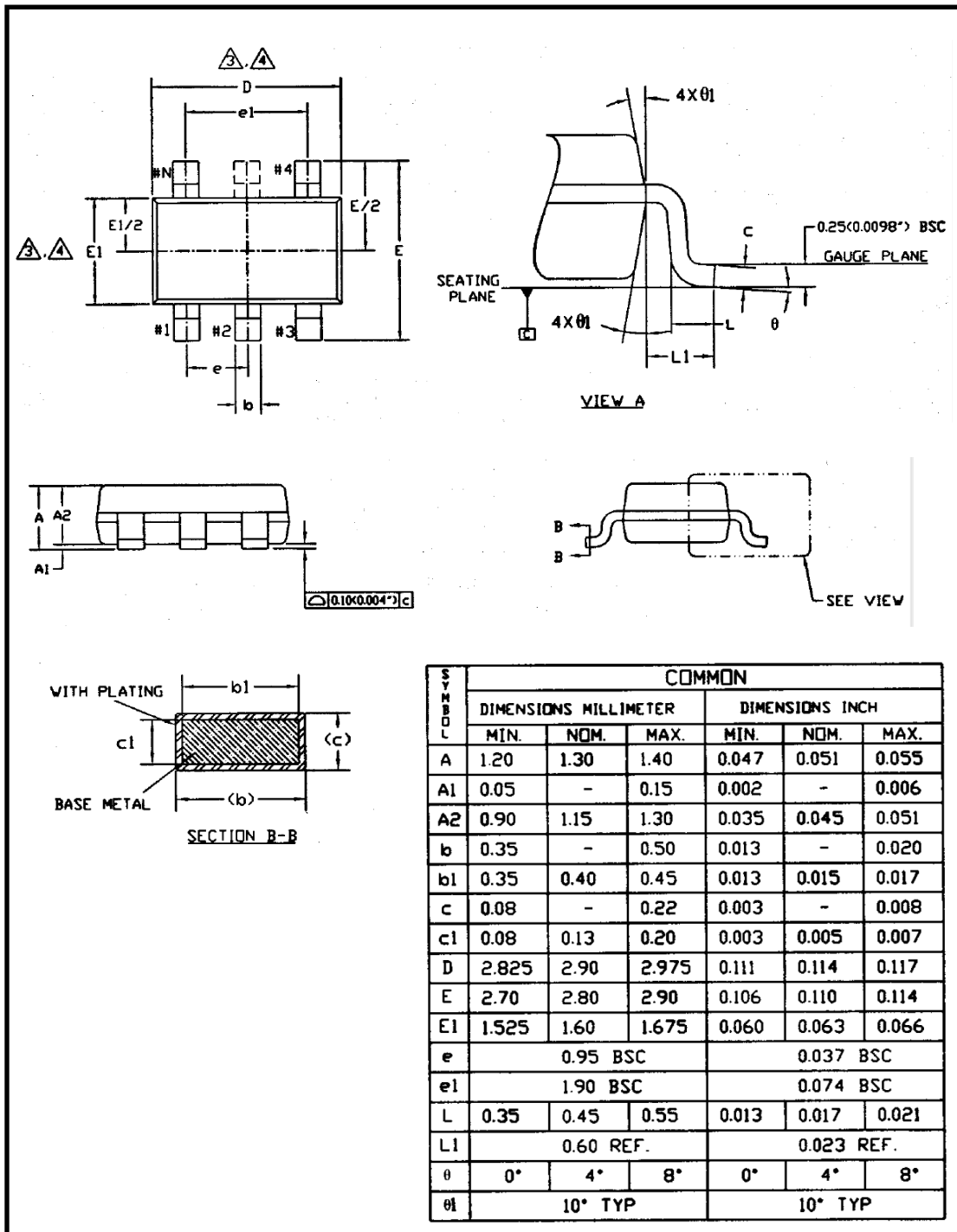

ADSemiconductor®

" Free from Common Mode Noise "

AWS01 (1-CH Differential Sensitivity Capacitive Touch Sensor)

NOTE:

1. Dimensioning and tolerancing per ASME Y 14.5 M – 1994.
2. Dimensions are in millimeters. Converted inch dimension are not necessarily exact.
3. Dimension D does not include mold flash, protrusions shall not exceed 0.15 mm per side.
Dimension E1 does not include interlead flash or protrusion. Interlead flash or protrusion shall not exceed 0.15 mm per side.
4. Top package may be smaller than the bottom package
Dimension D and E1 are determine at the outermost extremes of the plastic body exclusive of mold flash gate burrs and interlead flash.
5. Terminal numbers are shown for reference only.
Die is facing up for molding. Die is facing down for trim/form.
6. Solder thickness measured at flat section of lead between 0.08 mm and 0.15 mm from lead tip.
7. Foot length measured at intercept opine between gauge plane and lead surface.

8.2 Marking Description

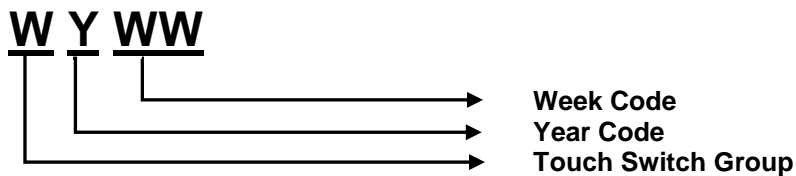

Year Code	P	R	S	T	U	V	W	X	Y	Z
Production Year	2007	2008	2009	2010	2011	2012	2013	2014	2015	2016

Year Code	A	B	C	D	E	F	G	H	K	M
Production Year	2017	2018	2019	2020	2021	2022	2023	2024	2025	2026

ADSemiconductor®

" Free from Common Mode Noise "

AWS01 (1-CH Differential Sensitivity Capacitive Touch Sensor)

NOTES:

LIFE SUPPORT POLICY

AD SEMICONDUCTOR'S PRODUCTS ARE NOT AUTHORIZED FOR USE AS CRITICAL COMPONENTS IN LIFE SUPPORT DEVICES OR SYSTEMS WITHOUT THE EXPRESS WRITTEN APPROVAL OF THE PRESIDENT AND GENERAL COUNSEL OF AD SEMICONDUCTOR CORPORATION

The ADS logo is a registered trademark of ADSemiconductor

© 2006 ADSemiconductor – All Rights Reserved

www.adsemicon.com
www.adsemicon.co.kr

X-ON Electronics

Largest Supplier of Electrical and Electronic Components

Click to view similar products for [Touch Screen Controllers](#) category:

Click to view products by [AD Semicon](#) manufacturer:

Other Similar products are found below :

[CY8CTMA461AA-33](#) [ATMXT1664T3-C2U](#) [CY8CTMA460AS-33](#) [CY8CTMA768AS-33](#) [ATMXT224-MAH](#) [CG8526AA](#) [FTCU04C](#)
[CP8667AT](#) [CP7598AT](#) [TSC2301IPAG](#) [AR1021-I/ML](#) [BU21025GUL-E2](#) [TSC2046EQPWRQ1](#) [CY8CMBR3116-LQXIT](#) [CYTMA445-](#)
[44LQI33ZZA](#) [AR1021T-I/ML](#) [TS01S](#) [TS02NT](#) [TS04](#) [TSM12M](#) [AD7877ACPZ-500RL7](#) [AD7873ARUZ](#) [AD7843ARUZ-REEL7](#)
[AD7843ARUZ](#) [AD7843ARQZ-REEL7](#) [AD7843ARQZ](#) [APT8L08SE](#) [HX612D](#) [IQS525-BL-QNR](#) [IQS572-BL-QNR](#) [SSD6250QN4R](#)
[AW9203CSR](#) [CP2682SS24-A1](#) [CY8CMBR2110-24LQXI](#) [CY8CMBR3106S-LQXI](#) [CY8CMBR3116-LQXI](#) [RH6015CF](#) [SD8223LC](#)
[SD8223LB](#) [BS812A-1](#) [SB8223](#) [TTP232-CA6](#) [RH6015D](#) [BS8112A-3](#) [BS8116A-3](#) [BS813A-1](#) [BS814A-1](#) [BS83A04A-3](#) [SC04A](#) [SC05A](#)