

DUAL PRECISION CMOS VOLTAGE COMPARATOR WITH PUSH-PULL DRIVER

GENERAL DESCRIPTION

The ALD2302A/ALD2302 are monolithic precision high performance dual voltage comparators built with advanced silicon gate CMOS technology. The primary features are: very high typical input impedance of $10^{12}\Omega$; low input bias current of 10pA; fast response time of 180ns; very low power dissipation of 175µA per comparator; and single (+5V) or dual ($\pm 5V$) power supply operation.

The input voltage range includes ground, which makes these comparators ideal for single supply low level signal detection with high source impedance. The outputs can source and sink current allowing for application flexibility. They can be used in either wired-OR connection without pull-up resistor or push-pull configuration. The ALD2302A/ALD2302 can also be used in wired-OR connection with other open drain circuits such as the ALD2301/ALD2303 voltage comparators.

The ALD2302A/ALD2302 voltage comparators are ideal for a great variety of applications, especially in low level signal detection circuits which require low standby power and high output current. For quad packages, use the ALD4302A/ALD4302 quad voltage comparator.

APPLICATIONS

- PCMCIA instruments
- MOSFET driver
- High source impedance voltage comparison circuits
- Multiple limit window comparator
- Power supply voltage monitor
- Photodetector sensor circuit
- High speed LED driver
- Oscillators
- Battery operated instruments
- Remote signal detection
- Multiple relay drivers

BENEFITS

- On-chip input and output buffers
- Precision voltage comparison capability
- Eliminate need for second power supply
- Eliminate pull-up resistor

ORDERING INFORMATION ("L" suffix for lead free version)

Operating Temperature Range *		
0°C to +70°C	0°C to +70°C	-55°C to +125°C
8-Pin Small Outline Package (SOIC)	8-Pin Plastic Dip Package	8-Pin CERDIP Package
ALD2302ASAL ALD2302SAL	ALD2302APAL ALD2302PAL	ALD2302ADA ALD2302DA

* Contact factory for leaded (non-RoHS) or high temperature versions.

FEATURES

- Guaranteed to drive 200Ω loads
- Fanout of 30LS TTL loads
- Low supply current of 175µA each comparator
- Pinout of LM193 type industry standard comparators
- Extremely low input bias currents -- typically 10pA
- Virtually eliminates source impedance effects
- Low operating supply voltage of 4V to 10V
- Single (+5V) and dual supply ($\pm 5V$) operation
- High speed for both large and small signals -- 180ns for TTL inputs and 400ns for 20mV overdrive
- CMOS, NMOS and TTL compatible
- Push-pull outputs-current sourcing/ sinking
- High output sinking current -- typically 60mA
- Low supply current spikes
- High gain -- 100V/mV

PIN CONFIGURATION

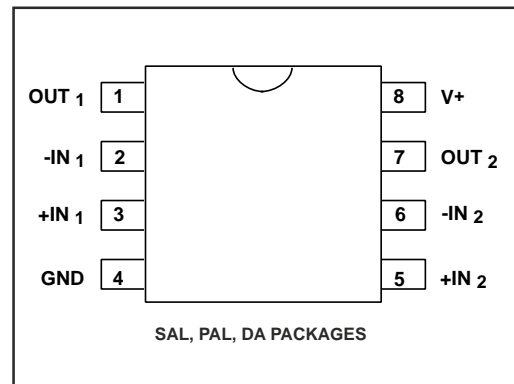

BLOCK DIAGRAM

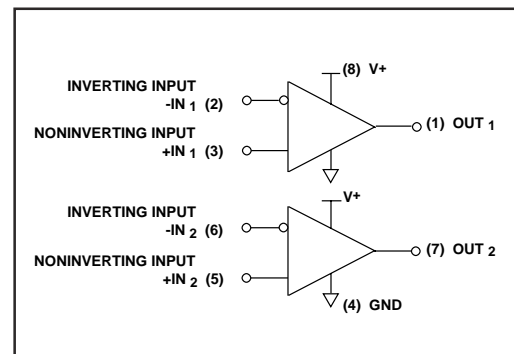

ABSOLUTE MAXIMUM RATINGS

Supply voltage, V+ _____ 10.6V
 Differential input voltage range _____ -0.3V to V+ +0.3V
 Power dissipation _____ 600 mW
 Operating temperature range SAL, PAL packages _____ 0°C to +70°C
 DA package _____ -55°C to +125°C
 Storage temperature range _____ -65°C to +150°C
 Lead temperature, 10 seconds _____ +260°C

OPERATING ELECTRICAL CHARACTERISTICS T_A = 25°C V+ = +5V unless otherwise specified

Parameter	Symbol	2302A			2302			Unit	Test Conditions
		Min	Typ	Max	Min	Typ	Max		
Supply Voltage	V _S	±2		±5	±2		±5	V	Dual Supply Single Supply
	V+	4		10	4		10	V	
Supply Current	I _S		350	500		350	500	µA	R _{LOAD} = ∞
Voltage Gain	A _{VD}	10	100		10	100		V/mV	R _{LOAD} ≥ 15KΩ
Input Offset Voltage	V _{OS}		0.5	1.8 2.8		1.5	4.8 5.8	mV	R _{LOAD} = 1.5KΩ 0°C ≤ T _A ≤ 70°C
Input Offset Current ¹	I _{OS}		10	200 800		10	200 800	pA	
Input Bias Current ¹	I _B		10	200 1000		10	200 1000	pA	0°C ≤ T _A ≤ 70°C
Common Mode Input Voltage Range ²	V _{ICR}	-0.3		V+ -1.5	-0.3		V+ -1.5	V	0°C ≤ T _A ≤ 70°C
Low Level Output Voltage	V _{OL}		0.18	0.4		0.18	0.4	V	I _{SINK} = 12mA V _{INPUT} = 1V Differential
Low Level Output Current	I _{OL}	24	60		24	60		mA	V _{OL} = 1.0V
High Level Output Voltage	V _{OH}	3.5	4.5		3.5	4.5		V	I _{OH} = -2mA
Response Time ²	t _{RP}		400			400		ns	C _L = 15pF 100mV Input Step/20mV Overdrive
			180			180		ns	C _L = 15pF TTL- Level Input Step

Notes: ¹ Consists of junction leakage currents
² Sample tested parameters

TYPICAL PERFORMANCE CHARACTERISTICS

SATURATION VOLTAGE vs. TEMPERATURE

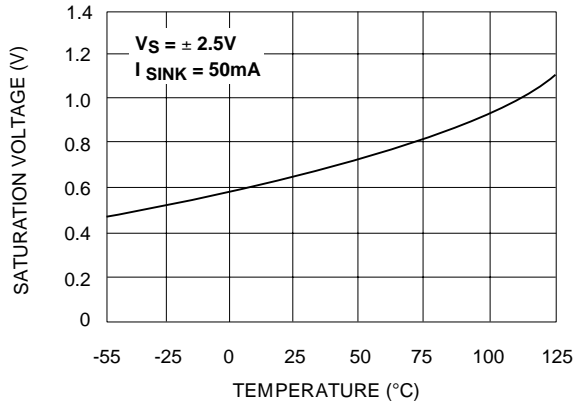

TRANSFER FUNCTION

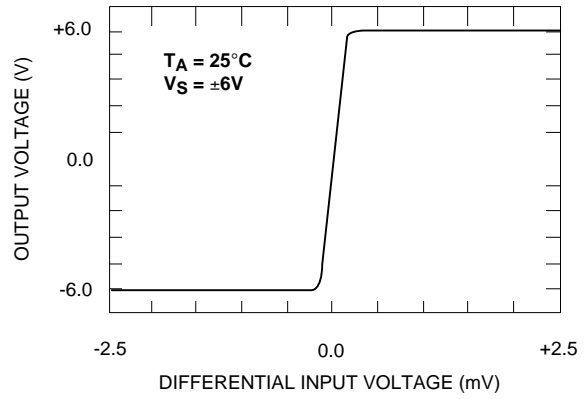

COMMON - MODE VOLTAGE REFERRED TO SUPPLY VOLTAGE

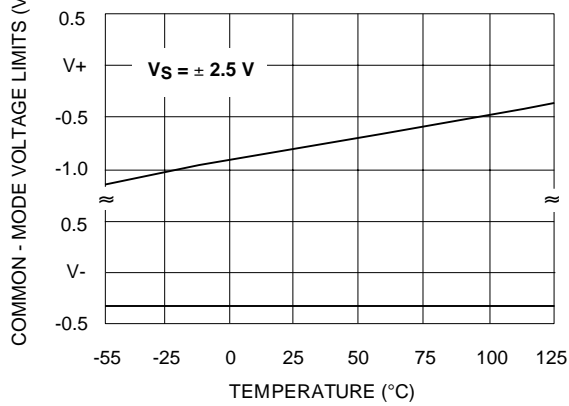

RESPONSE TIME FOR VARIOUS INPUT OVERDRIVES

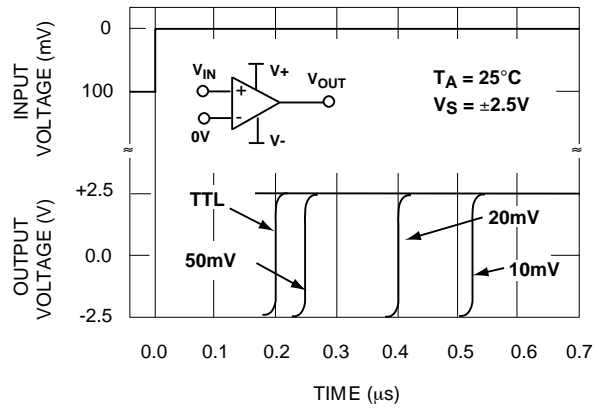

SATURATION VOLTAGE vs. SINK CURRENT

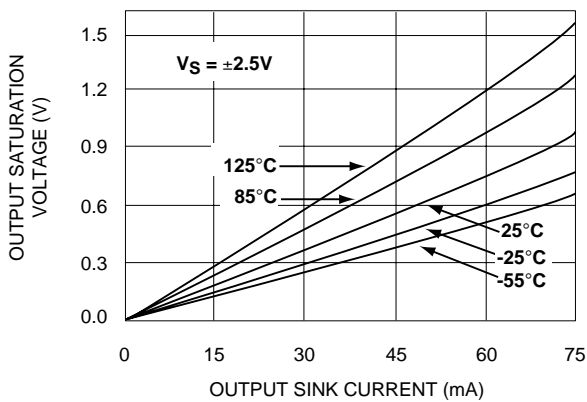

RESPONSE TIME FOR VARIOUS INPUT OVERDRIVES

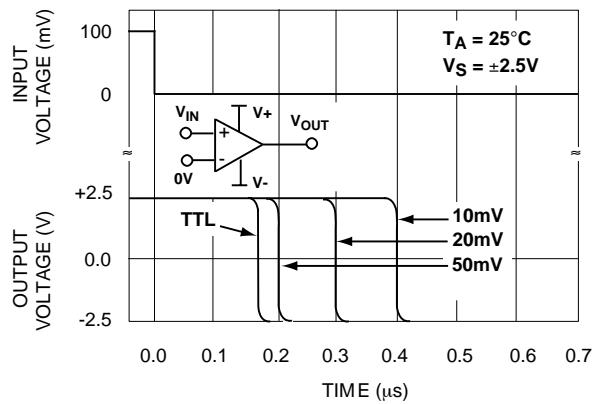

TYPICAL PERFORMANCE CHARACTERISTICS (cont'd)

TOTAL SUPPLY CURRENT vs. TOTAL SUPPLY VOLTAGE

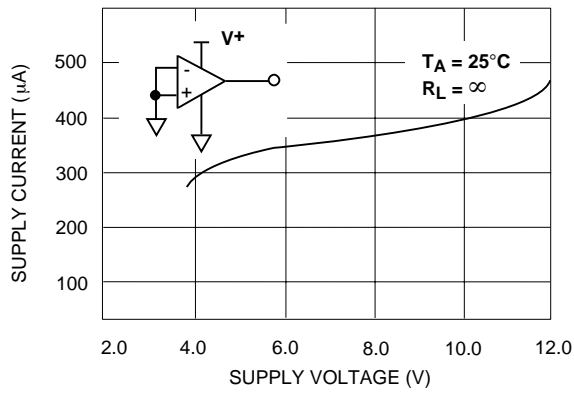

SUPPLY CURRENT vs. TEMPERATURE

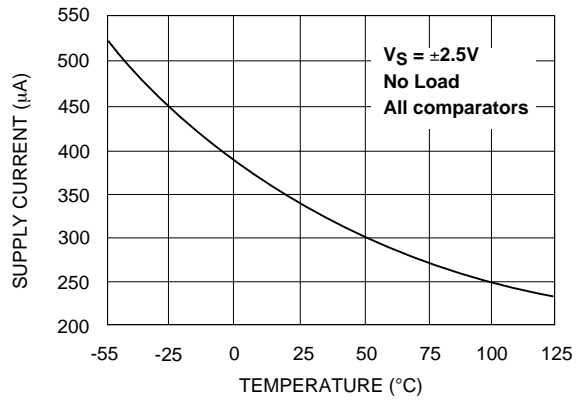

NORMALIZED INPUT OFFSET VOLTAGE vs. TEMPERATURE

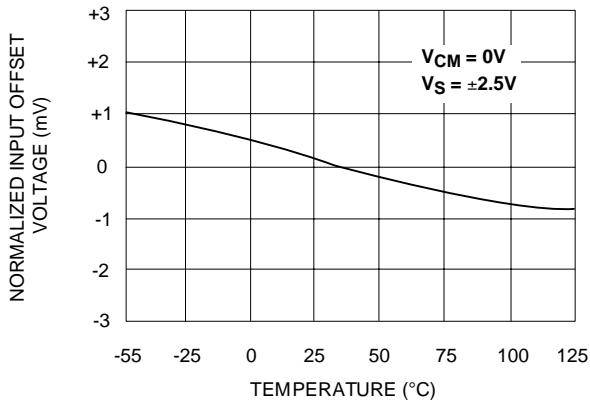

INPUT OFFSET VOLTAGE vs. SUPPLY VOLTAGE REPRESENTATIVE SAMPLES

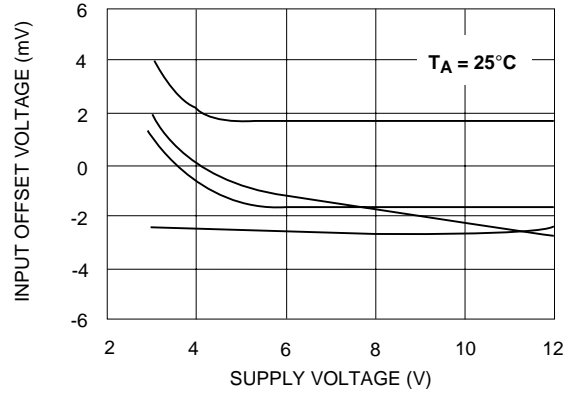

OUTPUT HIGH VOLTAGE vs. SUPPLY VOLTAGE

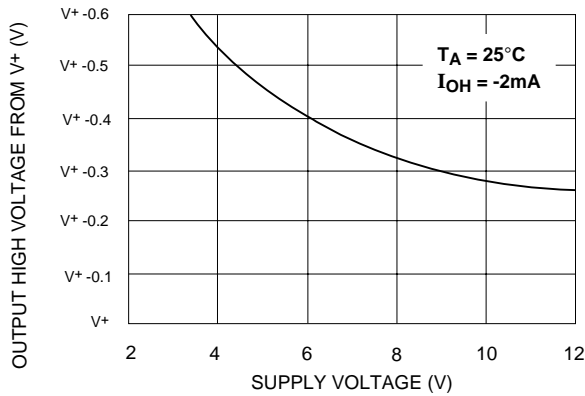

OUTPUT LOW VOLTAGE vs. SUPPLY VOLTAGE

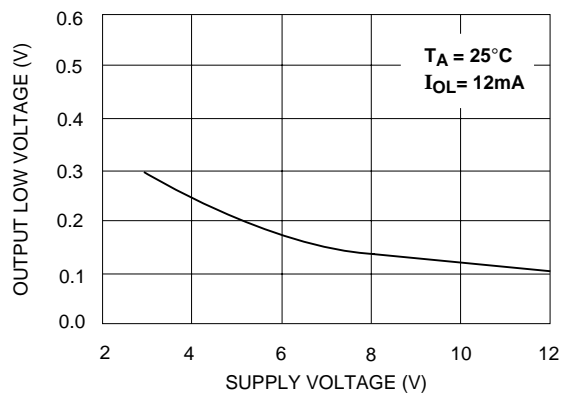

TYPICAL APPLICATIONS

ZERO CROSSING DETECTOR

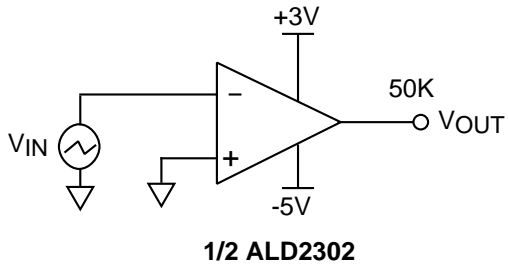

MULTIPLE RELAY DRIVE

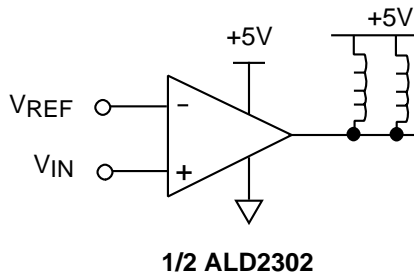

VOLTAGE LEVEL TRANSLATOR

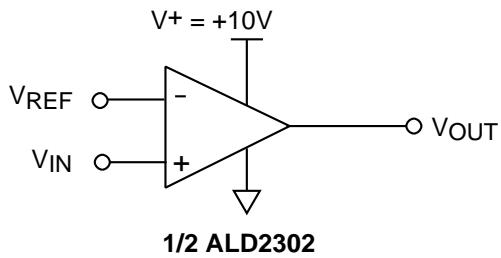

$V_{REF} = 1.4V$ for TTL input

$V_{REF} = \frac{V^+}{2}$ for CMOS input

Output V_{OUT} swings from rail-to-rail

DOUBLE DUAL LIMIT WINDOW COMPARATOR

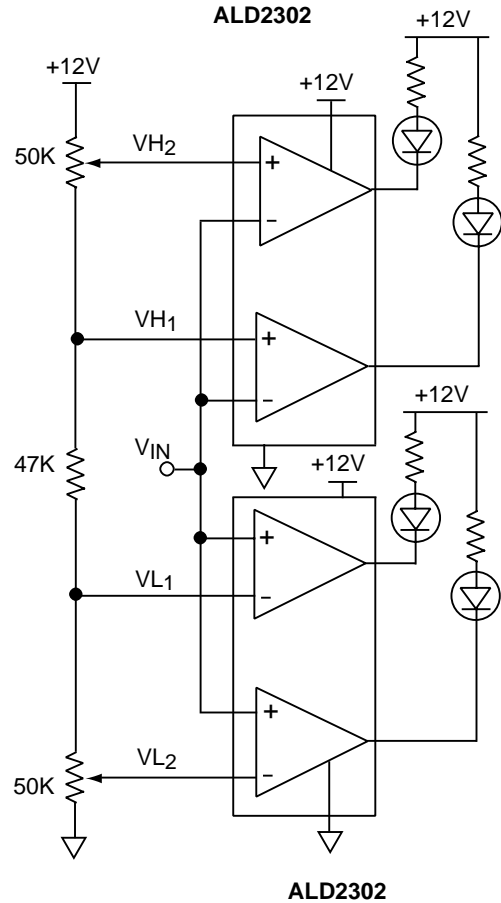

VL₁ and VH₁ first limit window send warning.
VL₂ and VH₂ second limit window execute system cutoff.

TYPICAL APPLICATIONS (cont'd)

PUSH-PULL COMPLEMENTARY POWER MOSFET DRIVER

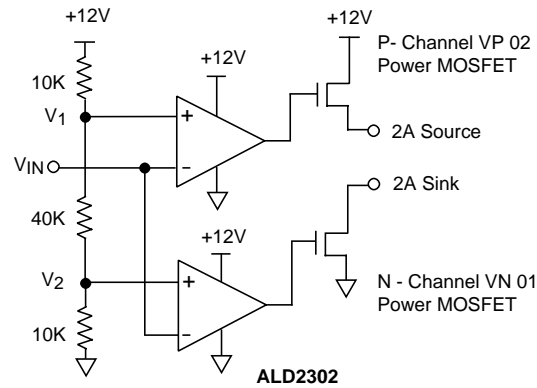

This circuit eliminates crossover current in the complementary power transistors. The outputs can be used to source and sink different loads or tied together to provide push-pull drive of the same load.

TIME DELAY GENERATOR

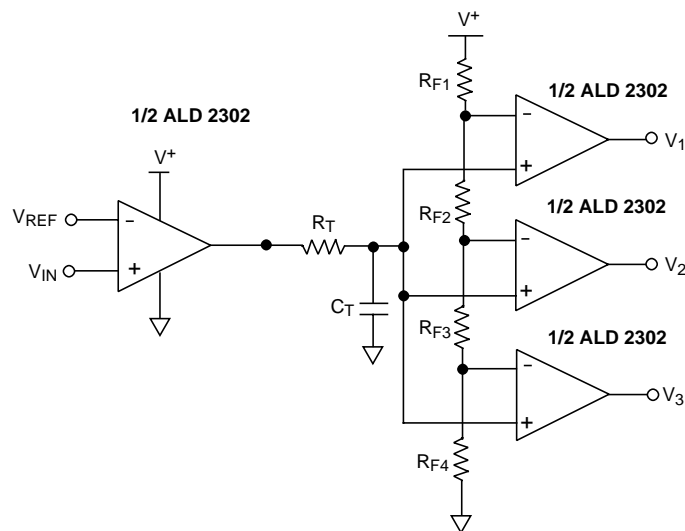

Design & Operating Notes:

1. As each output sources up to 10mA in the output high state, the output stage of a wired - OR low output circuit must be able to sink this current and still provide desired output voltage levels. For TTL output levels, this consideration limits the number to a maximum of three ALD2302 outputs wired-OR together.
2. In order to minimize stray oscillation, all unused inputs must be tied to ground.
3. The input bias and offset currents are essentially input protection diode reverse bias leakage currents, and are typically less than 1pA at room temperature. The currents are a function of ambient temperature, and would have to be considered in applications where very high source impedance or high accuracy are involved.
4. The high output sinking current of 60mA for each output offers flexibility in many applications, as a separate buffer or driver would not be necessary to drive the intended load. However, as the circuit normally operates close to ambient temperature due to its very low power consumption, thermal effects caused by large output current transients must be considered in certain applications.

SOIC-8 PACKAGE DRAWING

8 Pin Plastic SOIC Package

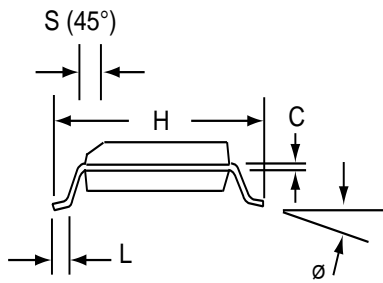
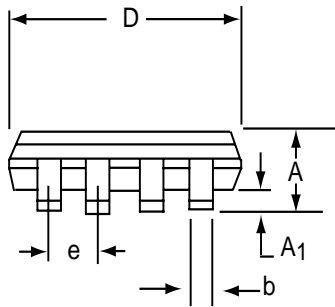
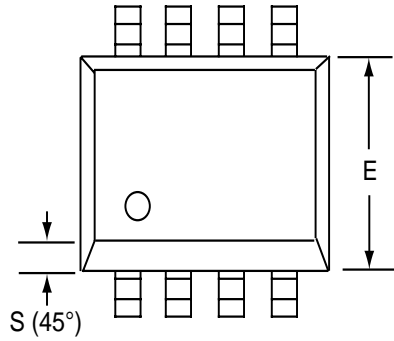

Dim	Millimeters		Inches	
	Min	Max	Min	Max
A	1.35	1.75	0.053	0.069
A ₁	0.10	0.25	0.004	0.010
b	0.35	0.45	0.014	0.018
C	0.18	0.25	0.007	0.010
D-8	4.69	5.00	0.185	0.196
E	3.50	4.05	0.140	0.160
e	1.27 BSC		0.050 BSC	
H	5.70	6.30	0.224	0.248
L	0.60	0.937	0.024	0.037
Ø	0°	8°	0°	8°
S	0.25	0.50	0.010	0.020

PDIP-8 PACKAGE DRAWING

8 Pin Plastic DIP Package

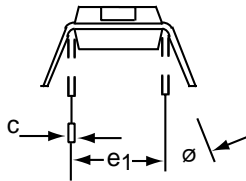
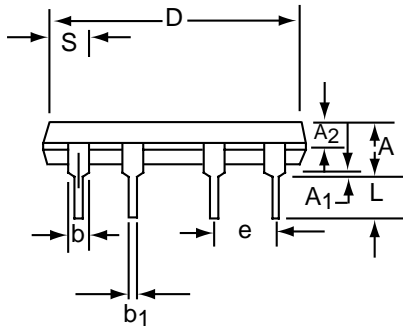
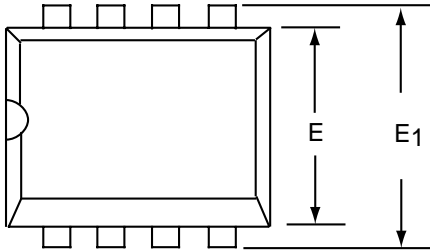

Dim	Millimeters		Inches	
	Min	Max	Min	Max
A	3.81	5.08	0.105	0.200
A ₁	0.38	1.27	0.015	0.050
A ₂	1.27	2.03	0.050	0.080
b	0.89	1.65	0.035	0.065
b ₁	0.38	0.51	0.015	0.020
c	0.20	0.30	0.008	0.012
D-8	9.40	11.68	0.370	0.460
E	5.59	7.11	0.220	0.280
E ₁	7.62	8.26	0.300	0.325
e	2.29	2.79	0.090	0.110
e ₁	7.37	7.87	0.290	0.310
L	2.79	3.81	0.110	0.150
S-8	1.02	2.03	0.040	0.080
ϕ	0°	15°	0°	15°

CERDIP-8 PACKAGE DRAWING

8 Pin CERDIP Package

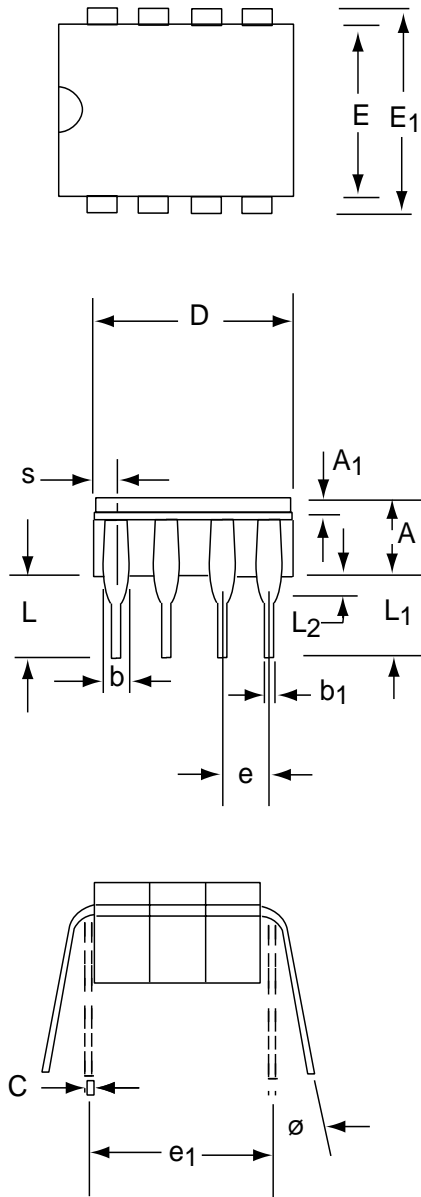

Dim	Millimeters		Inches	
	Min	Max	Min	Max
A	3.55	5.08	0.140	0.200
A ₁	1.27	2.16	0.050	0.085
b	0.97	1.65	0.038	0.065
b ₁	0.36	0.58	0.014	0.023
C	0.20	0.38	0.008	0.015
D-8	--	10.29	--	0.405
E	5.59	7.87	0.220	0.310
E ₁	7.73	8.26	0.290	0.325
e	2.54 BSC		0.100 BSC	
e ₁	7.62 BSC		0.300 BSC	
L	3.81	5.08	0.150	0.200
L ₁	3.18	--	0.125	--
L ₂	0.38	1.78	0.015	0.070
S	--	2.49	--	0.098
∅	0°	15°	0°	15°

X-ON Electronics

Largest Supplier of Electrical and Electronic Components

Click to view similar products for [Analog Comparators](#) category:

Click to view products by [Advanced Linear Devices](#) manufacturer:

Other Similar products are found below :

[SC2903VDR2G](#) [LM2901SNG](#) [LM339SNG](#) [UPC272G2-A](#) [55122](#) [5962-8757203IA](#) [NTE911](#) [LM339EDR2G](#) [NTE922](#) [LM2903M/TR](#)
[MAX49140AXK/V+T](#) [LM2903F-E2](#) [MCP6544-EP](#) [MCP6541UT-I/LT](#) [LM2901EDR2G](#) [TS391SN2T1G](#) [LM111JG](#) [LM139ADT](#)
[LM239APT](#) [HMC675LC3CTR](#) [MAX9024AUD+](#) [LT6700HVIS6-2#TRMPBF](#) [ADCMP394ARZ-RL7](#) [LM339AMX](#) [LTC1440IMS8#PBF](#)
[AZV331KSTR-G1](#) [LTC1841IS8#PBF](#) [LTC1440CN8#PBF](#) [LTC1542CS8#PBF](#) [LTC1445CS#PBF](#) [TL331VSN4T3G](#) [LT6700IDCB-](#)
[1#TRMPBF](#) [LTC1042CN8#PBF](#) [LTC1540CMS8#PBF](#) [ADCMP607BCPZ-R7](#) [LT1720CDD#PBF](#) [LTC1040CN#PBF](#) [LT6700MPDCB-](#)
[1#TRMPBF](#) [LT6700IDCB-3#TRMPBF](#) [LTC1440IS8#PBF](#) [S-89431ACNC-HBVTFG](#) [NTE1718](#) [NTE943](#) [NTE943M](#) [NTE943SM](#)
[TA75S393F,LF\(T](#) [ALD2301APAL](#) [ALD2302APAL](#) [TSX3704IYPT](#) [AD790JNZ](#)