

**6-CHANNEL SUPERCAPACITOR AUTO BALANCING PCB**

**GENERAL DESCRIPTION**

The SABMB6 is a 6-channel Printed Circuit Board (PCB) designed to be used with any member of the ALD9100XX family of SAB™ MOSFETs for system designers and application developers. SAB MOSFETs are exclusive EPAD® MOSFETs that address leakage and voltage balance of supercapacitor cells connected in series. Imbalance of leakage currents, although much smaller in magnitude than charging or discharging currents, need to be balanced, as leakage currents are long-term DC values that integrate and accumulate over time. SAB MOSFETs and the SABMB6 boards are compact, economical and effective in balancing any size supercapacitors with little or no additional power dissipation. Each SABMB6 can balance up to six supercapacitors in a series stack. It is the newest board to join the popular SABMB16, which can balance two to four supercapacitors in a series stack. These boards can be cascaded to balance multiple series stacks of up to six supercapacitors each.

The SABMB6 is a simple, out-of-the-box plug-and-play PCB solution for development, prototyping, demonstration and evaluation, or production deployment. It is suited for balancing supercapacitor stacks ranging from six in series to hundreds in series, and for supercapacitors of 0.1F to 3000F and beyond. The average additional power dissipation due to use of SABMB boards is zero, which makes this method of supercapacitor balancing very energy efficient. It is especially suited for low loss energy harvesting and long life battery operated applications.

Supercapacitors, also known as ultracapacitors, when connected two cells in series can be balanced with a single ALD9100XX package installed. Supercapacitors, when connected more than two cells in series, can be balanced with more than one SABMBXX board (each with ALD9100XX packages installed).

**ORDERING INFORMATION**

Part Number	Description
SABMB6	Blank Universal PCB ready for three ALD9100XX Dual SAB MOSFETs
SABMB6XX	SABMB6 Board with three ALD9100XXSALI
Example: SABMB625	SABMB6 Board with three ALD910025SALI

Note: SABMB6XX is optional with specific ALD9100XXSALI units installed. XX = 16, 17, 18, 19, 20, 21, 22, 23, 24, 25, 26, 27, 28, 29, 30.

See page 4 for full listing of part numbers.

The SABMB6 is a blank PCB, ready for an ALD9100XX to be installed. For example, the SABMB625 is a SABMB6 board with three ALD910025SALI installed and tested. These are rated for industrial temperature of -40°C to +85°C.

The SABMB6 board includes the following features for flexibility in a variety of different applications:

- 1) Three ALD9100XX Dual SAB MOSFET units installed per board.
- 2) Optional reverse biased external clamping power diodes (schottky rectifiers) can be installed, on board where necessary, across each SAB MOSFET.
- 3) Multiple SABMB6 PCBs can be cascaded to form a series chain, paralleling a series-connected chain of supercapacitor cells.
- 4) Compact size of 0.6 in. by 1.6 in. with mounting holes.
- 5) Rated for RoHS compatible/industrial temperature range of -40°C to +85°C.

**MECHANICAL DRAWING**

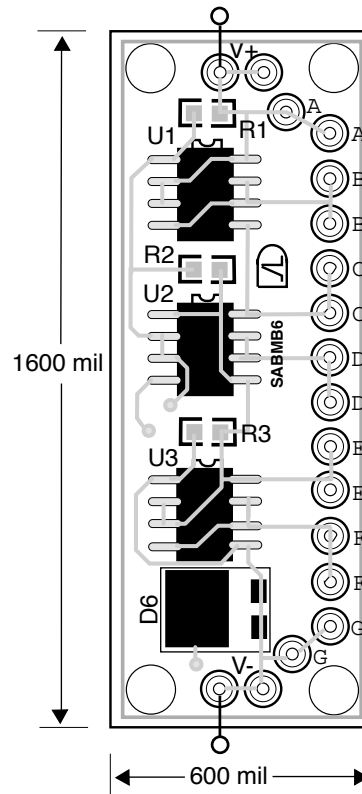

\* Magnified, not to scale

The ALD9100XX SAB MOSFET family offers the user a selection of different threshold voltages for various supercapacitor nominal operating voltage values and desired leakage balancing characteristics. Each SAB MOSFET generally requires connecting its V+ pin to the most positive voltage and its V- and IC pins to the most negative voltage within the package. Note that each Drain pin has an internal reverse biased diode to its Source pin, and each Gate pin has an internal reverse biased diode to V-. All other pins must have voltages within V+ and V- voltage limits within the same package unit.

Standard ESD protection facilities and handling procedures for static sensitive devices must also be used while installing the ALD9100XX units. Once installed, the connection configuration will protect the ALD9100XX units from ESD damage. When connected to a supercapacitor stack, the ALD9100XX is further protected from virtually any ESD damage due to the large capacitance of the supercapacitors, which sinks any ESD charge and thereby reduces any of the terminal voltages to minimal harmless values.

### SABMB6 PRINTED CIRCUIT BOARDS

The SABMB6 Printed Circuit Board is available as a blank PCB board, made with RoHS compliant FR4 material, ready for mounting three 8-lead ALD9100XX units. These units are also supplied and available with a 2-digit suffix, which denotes the specific ALD9100XX component mounted and tested on the PCB. All that is required of the user is to mount the PCB and wire the appropriate connections from the SABMB6 board to the respective supercapacitor nodes.

Each SABMB6 Printed Circuit Board has three 8-lead SOIC footprints and terminals labeled V+, A to G, and V-. Each of these terminals has two wiring holes for easier connection of the same terminal node to two external connection points. V+ is directly connected to terminal A, which must be connected to the most positive voltage for the individual SABMB6 board. V- is directly connected to terminal G, which must be connected to the most negative voltage present for the same SABMB6 board. The other terminals, namely B through F, must have voltages between V+ and V- for proper operation of the board.

When six supercapacitors are installed to be balanced by SAB MOSFETs, three ALD9100XX units can be mounted on the SABMB6. Any number of SABMB6 boards can be daisy-chain connected in series. For example, three SABMB6 boards, each with three ALD910025SALI installed, can be connected in series to a +42V power supply, provided care is taken to insure that each SABMB6 board V- is connected to the V+ of the next SABMB6 board in series, such that each board would have typical internal voltages from V+ to V- of +14.0V (+15.0V max.). Each individual ALD910025SALI IC chip on the board has a +15.0V max. rating, but each actually experiences only about +5.0V.

The ALD9100XX is rated for reverse bias diode currents of up to 80mA maximum for each SAB MOSFET on board. Any reverse bias condition as a result of changing supercapacitor voltages, especially during fast supercapacitor discharge, could lead to some internal nodes temporarily reverse biased with surge current in excess of this limit. The SABMB6 board has additional optional TO277 footprints for mounting external schottky rectifiers (power diodes) to clamp such surge current transients. The user is advised

to determine the various power and current limits, including temperature and heat dissipation considerations, when selecting a suitable component for such purpose. The appropriate level of derating and margin allowance must also be added to assure long term reliability of the PCB board.

### SUPERCAPACITORS

Supercapacitors are typically rated with a nominal recommended working voltage established for long life at their maximum rated operating temperature. Excessive supercapacitor voltages that exceed the supercapacitor's rated voltage for a prolonged time period will result in reduced operating life and eventual rupture and catastrophic failure. To prevent such an occurrence, a means of automatically adjusting (charge-balancing) and monitoring the maximum voltage is required in most applications having two or more supercapacitors connected in series, due to the different internal leakage currents that vary from one supercapacitor to another.

Each supercapacitor has a tolerance difference in capacitance, internal resistance and leakage current. These differences create imbalance in cell voltages, which must be balanced so that any individual cell voltage does not exceed its rated max. voltage. Initially, cell voltage imbalance is caused by capacitance value differences. Supercapacitors selected from the same manufacturer make and model batch can be measured and matched to deliver reasonable initial cell voltages. Next, cell voltage imbalance due to individual cell leakage currents must be compensated.

The supercapacitor leakage current itself is a variable function of its many parameters such as aging, initial leakage current at zero input voltage, the material/construction of the supercapacitor, and the operating bias voltage. Its leakage is also a function of the charging voltage, the charging current, operating temperature range and the rate of change of many of these parameters. Supercapacitor balancing must accommodate these changing conditions.

By using the appropriate ALD SAB MOSFET and the appropriate SABMBXX board, users can compensate for all of these causes of imbalance and automatically balance supercapacitors.

### ENERGY HARVESTING APPLICATIONS

Supercapacitors offer an important benefit for energy harvesting applications using a low energy source, by buffering and storing such energy to drive a higher power load.

For energy harvesting applications, supercapacitor leakage currents are a critical factor, as the average energy harvesting input charge must exceed the average supercapacitor internal leakage currents in order for any net energy to be harvested and saved. Often, the input energy is variable, meaning that its input voltage and current magnitude are not constant and may be dependent upon a whole set of other parameters such as the source energy availability, energy sensor conversion efficiency, changing environmental conditions, etc.

SAB MOSFETs used for charge balancing, due to their high input threshold voltages, are completely turned off initially, consuming zero drain current while the supercapacitor is being charged,

maximizing any energy harvesting gathering efforts. The SAB MOSFET does not become active until the supercapacitor is already charged to over 90% of its max. rated voltage. The trickle charging of supercapacitors with energy harvesting techniques tends to work well with SAB MOSFETs as charge balancing devices, as it is less likely to have high transient energy spurts resulting in excessive voltage or current excursions.

If an energy harvesting source only provides a few  $\mu\text{A}$  of current, the power budget does not allow wasting any of this current on capacitor leakage currents and power dissipation of resistor or operational amplifier based charge-balancing circuits. It may also be important to reduce long term leakage currents, as energy harvesting charging at low levels may take up to many days.

In summary, in order for an energy harvesting application to be successful, the input energy harvested must exceed all the energy required, due to the leakages of the supercapacitors and the charge-balancing circuits, plus any load requirements. With their unique balancing characteristics and near-zero charge loss, SAB MOSFETs are ideal devices for use in supercapacitor charge-balancing in energy harvesting applications.

### BATTERY POWERED APPLICATIONS

Many battery powered circuits requiring a supercapacitor to boost power output can benefit from using SAB MOSFETs for supercapacitor balancing. The additional power burn by using SAB MOSFETs for supercapacitor stack balancing can actually be negative, as adding SAB MOSFETs can save supercapacitor leakage current and associated power dissipation by lowering the operating bias voltage of the leakier supercapacitor. Applications that depend on long life battery usage must take into account the supercapacitor leakage current and balancing circuit power burn because the currents involved are steady state DC currents that are continuous throughout the lifetime of the application and its battery life. The average added power dissipation with the addition of the SABMB6 board is zero, provided the selection of the operating voltages and SAB MOSFETs are appropriate for the leakage currents of the supercapacitors specified.

### CONNECTION TO OTHER SABMBXX PCBs

The SABMB6 is compatible with other SABMBXX boards and is designed to be used along with other SABMBXX boards connected in series to achieve balancing the corresponding number of supercapacitors installed in a stack. For example, nine supercapacitors in series can be balanced with one SABMB6 PCB and one SABMB16 PCB connected in series.

For more information on the CHARACTERISTICS OF SUPERCAPACITOR AUTO BALANCING (SAB™) MOSFETS, please refer to the following documents:

- \*ALD8100XX/ALD9100XX FAMILY of SUPERCAPACITOR AUTO BALANCING (SAB™) MOSFET ARRAYS
- \* Individual datasheet for chosen SAB MOSFET.

### CAUTION:

**Users must limit the voltage across any ALD9100XX chip to 15.0V max.**

### SABMB6 PCB CONNECTION TO SUPERCAPACITORS C1 TO C6

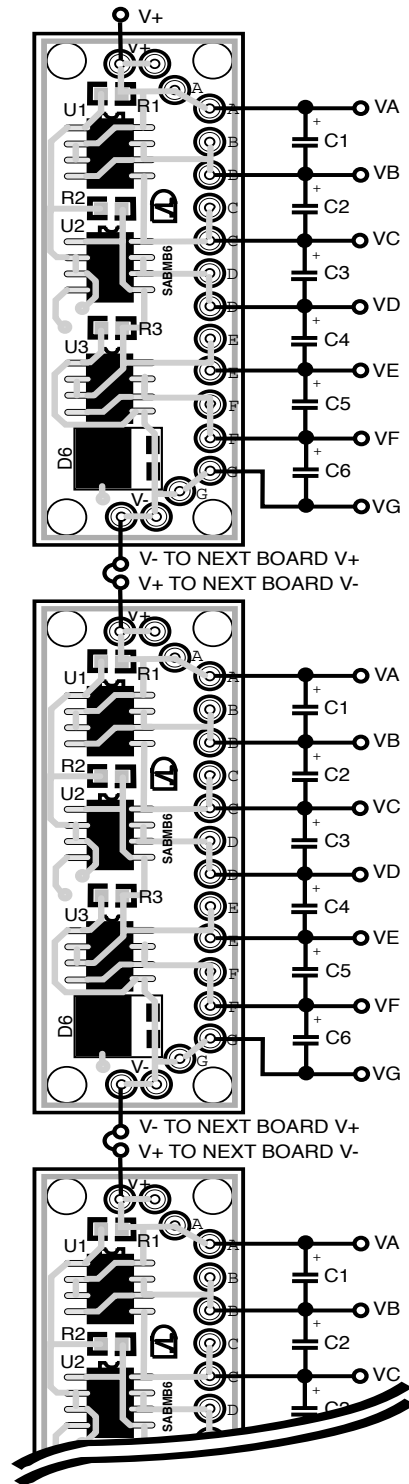

\* Magnified, not to scale

## TYPICAL APPLICATION

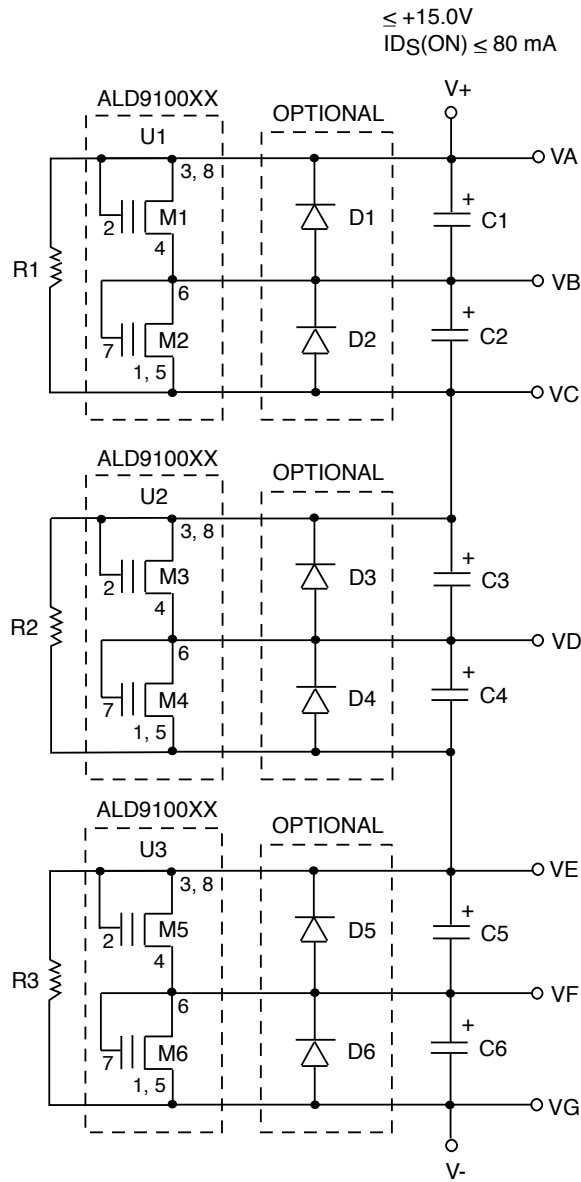

### NOTES

1. R1, R2, R3: USER SPECIFIED VALUES FROM OPEN CIRCUIT TO ZERO (0.0) OHMS
2. U1, U2, U3: 8L SOIC ALD9100XXSALI
3. D1 THROUGH D6: OPTIONAL SCHOTTKY RECTIFIER FOR REVERSE CURRENT CLAMPING (TO277 FOOTPRINT)
4. C1 THROUGH C6: SUPERCAPACITORS EXTERNAL TO THE SABMB6 PCB

### PCB PRODUCT PART NUMBERS

SABMB6	(blank PC Board)
SABMB616	(SAMB6 with three ALD910016SALI)
SABMB617	(SAMB6 with three ALD910017SALI)
SABMB618	(SAMB6 with three ALD910018SALI)
SABMB619	(SAMB6 with three ALD910019SALI)
SABMB620	(SAMB6 with three ALD910020SALI)
SABMB621	(SAMB6 with three ALD910021SALI)
SABMB622	(SAMB6 with three ALD910022SALI)
SABMB623	(SAMB6 with three ALD910023SALI)
SABMB624	(SAMB6 with three ALD910024SALI)
SABMB625	(SAMB6 with three ALD910025SALI)
SABMB626	(SAMB6 with three ALD910026SALI)
SABMB627	(SAMB6 with three ALD910027SALI)
SABMB628	(SAMB6 with three ALD910028SALI)
SABMB629	(SAMB6 with three ALD910029SALI)
SABMB630	(SAMB6 with three ALD910030SALI)

## X-ON Electronics

Largest Supplier of Electrical and Electronic Components

*Click to view similar products for* [Power Management IC Development Tools](#) *category:*

*Click to view products by* [Advanced Linear Devices](#) *manufacturer:*

Other Similar products are found below :

[EVB-EP5348UI](#) [BQ25010EVM](#) [ISL80019AEVAL1Z](#) [ISLUSBI2CKIT1Z](#) [ISL8002AEVAL1Z](#) [ISL91108IIA-EVZ](#) [MAX8556EVKIT](#)  
[MAX15005AEVKIT+](#) [ISL28022EVKIT1Z](#) [STEVAL-ISA008V1](#) [DRI0043](#) [KITPF8100FRDMEVM](#) [EVB-EN6337QA](#)  
[SAMPLEBOXILD8150TOBO1](#) [MAX18066EVKIT#](#) [AP62300WU-EVM](#) [KITA2GTC387MOTORCTRTOBO1](#) [AEK-MOT-TK200G1](#)  
[EVLONE65W](#) [STEVAL-ILH006V1](#) [STEVAL-IPE008V2](#) [STEVAL-IPP001V2](#) [STEVAL-ISA013V1](#) [STEVAL-ISA067V1](#) [STEVAL-](#)  
[ISQ002V1](#) [TPS2306EVM-001](#) [TPS2330EVM-185](#) [TPS40001EVM-001](#) [SECO-HVDCDC1362-15W-GEVB](#) [BTS7030-2EPA](#)  
[LT8638SJV#WPBF](#) [LTC3308AIV#WTRPBF](#) [TLT807B0EPV](#) [BTS71033-6ESA](#) [EV13N91A](#) [EASYPIC V8 OVER USB-C](#) [EV55W64A](#)  
[CLICKER 4 FOR STM32F4](#) [EASYMX PRO V7A FOR STM32](#) [CLICKER 4 FOR PIC18F](#) [Si8285\\_86v2-KIT](#) [PAC52700EVK1](#) [NCP-](#)  
[NCV51752D2PAK3LGEVB](#) [ISL81807EVAL1Z](#) [AP33772S-EVB](#) [EVALM7HVIGBTFCINV4TOBO1](#) [903-0300-000](#) [902-0173-000](#) [903-](#)  
[0301-000](#) [ROA1286023/1](#)