

Specification For Approval

Date: 2009 / 09 / 09

File No.: 090909008



Version: 1.0

Customer : 研華股份有限公司

Customer P/N : /

INVAX P/N : AN8921F-5701SM

Description : Antenna

Cortec Checked By:	
Customer Approved By:	



INVAX System Technology Corp.
4F. No. 815.Chung Hsiao East Rd.,Sec.5
Taipei, TAIWAN

TEL:886-2-2788-5218 FAX:886-2-2783-1658
<http://www.invaxsystem.com>



Cortec Technology Inc.
Xian-Xi Industrial, Sha-Tou Administration Zone,
Chang-An Town, Dong-Guan City, Guangdong
Province, China

TEL:86-769-85388261 FAX:86-769-85317869
<http://www.cortec.com.cn>

Index:

- 1. Specification / Page 2**
- 2. Characteristics and Reliability Test / Page 3**
- 3. Antenna - S Parameter Test Data / Page 4**
- 4. Antenna - Radiation Pattern Test Data / Page 5 ~ 7**
- 5. Mechanical and Packing Drawing / Page 8 ~ 9**
- 6. Material Description and RoHS Test Report / Page 10 ~ end**

Product Number: AN8921F-5701SM

Product Name: Antenna



1. Specification

Sample Photo	
	
A. Electrical Characteristics	
Frequency	824 ~ 960 MHz 1710 ~ 2170 MHz
S.W.R.	≤ 6.0 @ 824 ~ 960 MHz ≤ 4.0 @ 1710 ~ 2170 MHz Tested at 290mm Square Ground Plane
Antenna Average Gain	- 10 ~ - 6dBi @ 824 ~ 960 MHz - 8 ~ + 1dBi @ 1710 ~ 2170 MHz Tested at 290mm Square Ground Plane
Polarization	Linear
Impedance	50 Ohm
B. Material & Mechanical Characteristics	
Material of Radiator	Cu
Material of Plastic	Body: TPE Hinge: PA+ABS Holder: PA+ABS
Cable Type	RG-178
Connector Type	SMA Male
Connector Pull Test	≥ 3 Kg
Connector Torque Test	100 ~ 300 g.cm
C. Environmental	
Operation Temperature	- 40 °C ~ + 65 °C
Storage Temperature	- 40 °C ~ + 80 °C

2. Characteristics and Reliability Test

Test Items		Test Condition and Procedure	Requirements
C1	S.W.R.	Set DUT on Network Analyzer; make individual calibration to test	Directive DUT specification
C2	Antenna Gain	Set DUT on Antenna Chamber; make individual calibration to test	Directive DUT specification
M1	Vibration	MIL-STD-202G, 201A Amplitude: 0.03 inch (0.76mm); Freq: 10 to 55 Hz 3 directions; 2 hours for each direction	1. No Visual Damage 2. Frequency Tol.<= 5%
M2	Random Drop	Height: 1.5 Meter; 3 directions; 1 time for each direction	1. No parts separated 2. Frequency Tol.<= 5%
M3	Solderability	MIL-STD-202G, 210F, cond. A Solder iron: 350±10°C; Duration: 5 seconds	1. Mounted on PCB 2. No Visual Damage
M4	Terminal-Pull Test	MIL-STD-202G, 211A, cond. A Holding with individual specification; force applied to axis of terminal	1. Directive DUT specification 2. Frequency Tol.<= 5%
M5	Terminal-Torque Test	MIL-STD-202G, 211A, cond. E Holding with individual specification; applied clockwise and counterclockwise to the axis of terminal	1. Directive DUT specification 2. Frequency Tol.<= 5%
M6	Dimension	Inspection of dimension, color, material, package, surface process	Directive DUT specification
E1	Salt Spray	MIL-STD-202G, 101E, cond. B Temp: 35°C; RH: >= 95%; NaCl solution: >= 5%; Time: 48 hours	After 2 Hours Recovery 1. No Visual Damage 2. Frequency Tol.<= 5%
E2	Humidity	MIL-STD-202G, 103B, cond. B Temp: 40°C; RH: >= 95%; Time: 48 hours	After 2 Hours Recovery 1. No Visual Damage 2. Frequency Tol.<= 5%
E3	Thermal Shock	1 Cycle: - 40°C (30 minutes) to + 80°C (30 minutes) Cycles: 24	After 2 Hours Recovery 1. No Visual Damage 2. Frequency Tol.<= 5%
E4	Life (High Temp.)	MIL-STD-202G, 108A, cond. A Temp: 85°C; Time: 96 hours	After 2 Hours Recovery 1. No Visual Damage 2. Frequency Tol.<= 5%
R1	RoHS	With Reference to IEC 62321:2008 with flow chart	Directive RoHS 2002/95/EC
R2	PFOS	With Reference to USA EPA 3540C:1996 by LC/MS	Directive RoHS 2006/122/EC
R3	PFOA	With Reference to USA EPA 3540C:1996 by LC/MS	Directive RoHS 2006/122/EC

3. Antenna - S Parameter Test Data

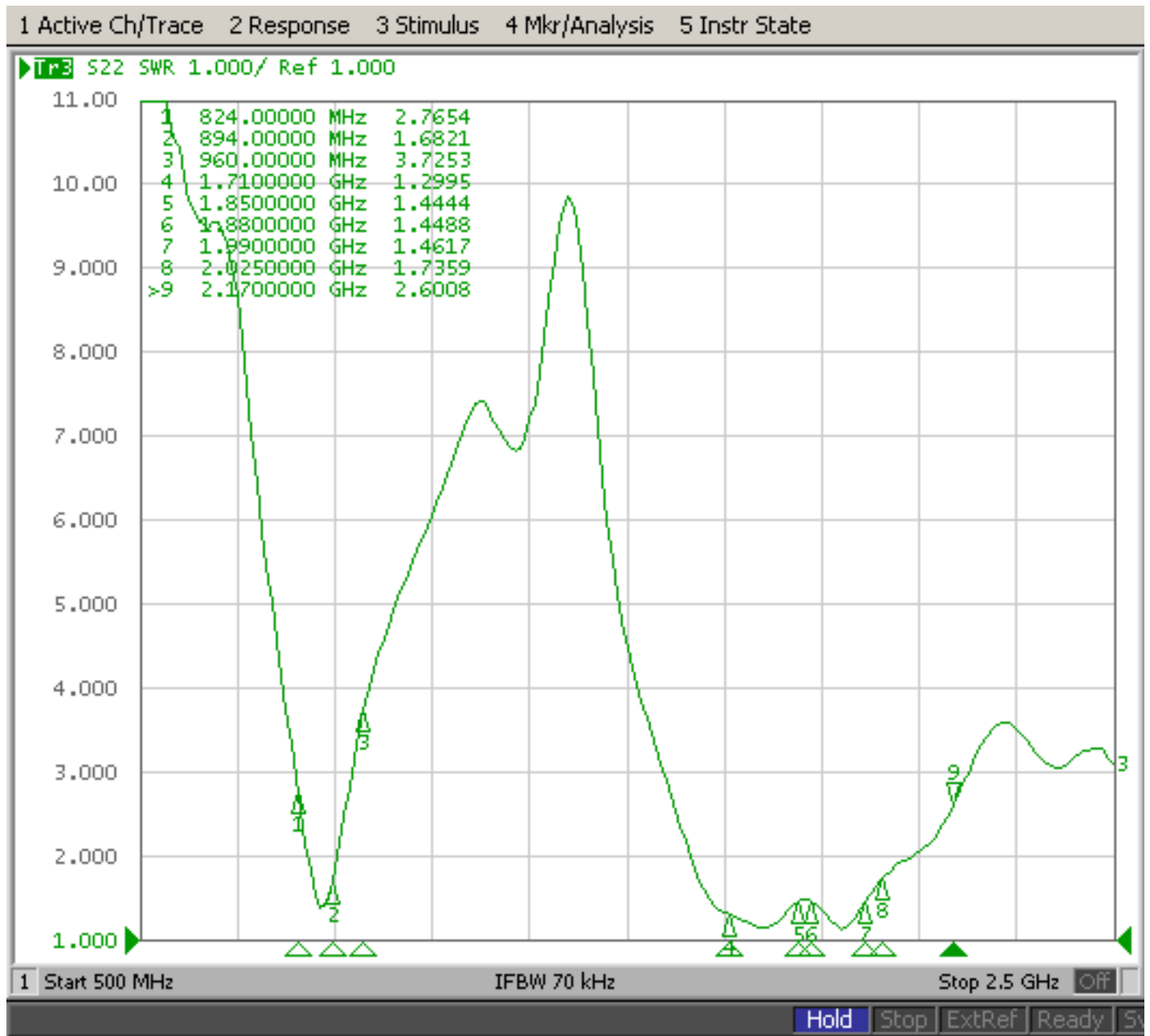

Product Number: AN8921F-5701SM

Product Name: Antenna



4. Antenna - Radiation Pattern Test Data

Testing Equipment Specification:

Antenna Anechoic Chamber Dimension: 8 x 4 x 4 m

Quiet Zone: 600mm @1 GHz

Isolation: >100dB @ 1 MHz ~ 10 GHz

Testing Equipment: Agilent 5071B

Received Antenna: 0.7 ~ 6.0 GHz for Gain Calibration

Double Ridged Horn Antenna

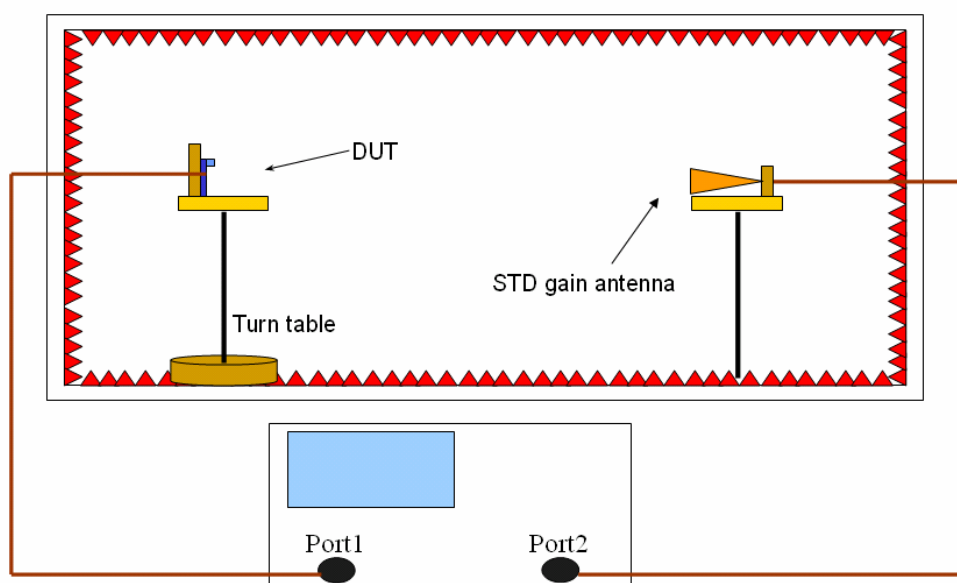

5. Mechanical Drawing

See attached files

6. Material Description and RoHS Test Report

See attached files



Cortec Technology Inc.

广东省东莞市长安镇振安路沙头段咸西工业区

Model : AN8921F-57 Antenna
Remark : H-Plane // V-Pol
Tested by : CORTEC Antenna 3D Lab // Zhao Yao Rong

Freq. (MHz)	824	830	850	880
Peak Gain (dBi)	-9.3	-9.17	-8.01	-7.66
Peak Degree	69	76	184	17
AV Gain (dBi)	-9.85	-9.72	-8.67	-8.41

Location: **Chamber**

Date: 2009/9/1

Time: 下午 07:15:20

Temperatuer (°C): 22.00

Humidity (%): 55.00

Approved by:

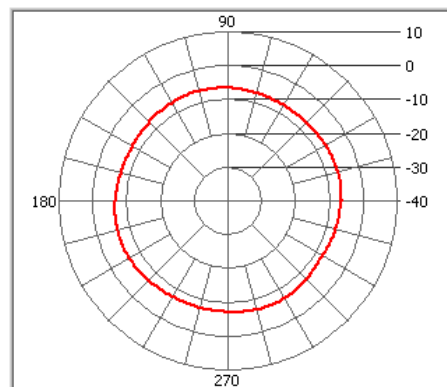
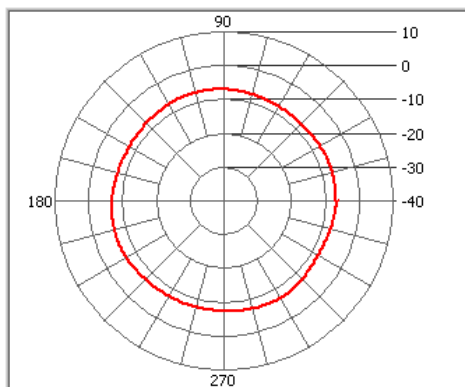
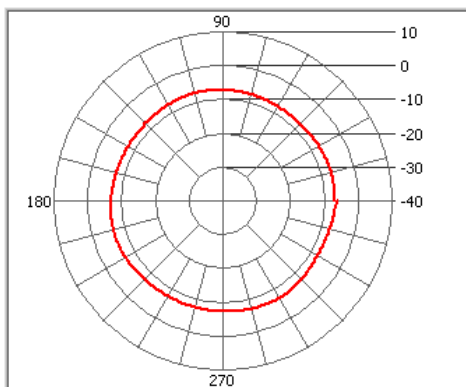
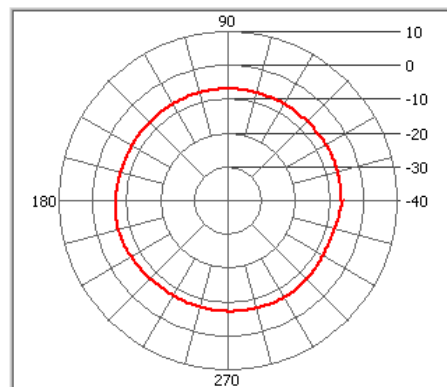
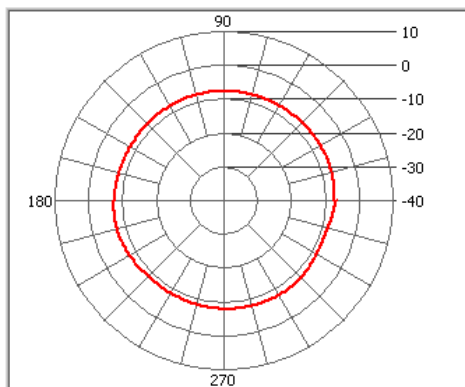
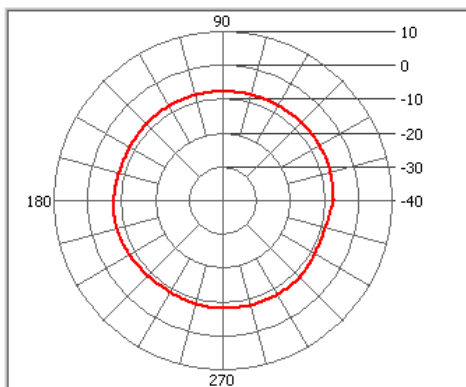
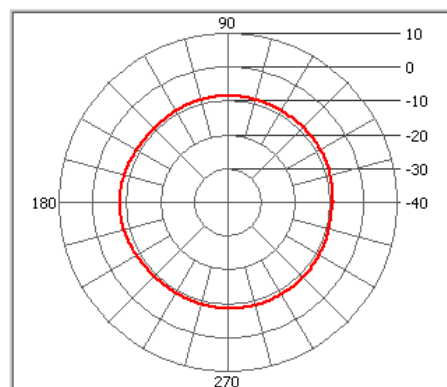
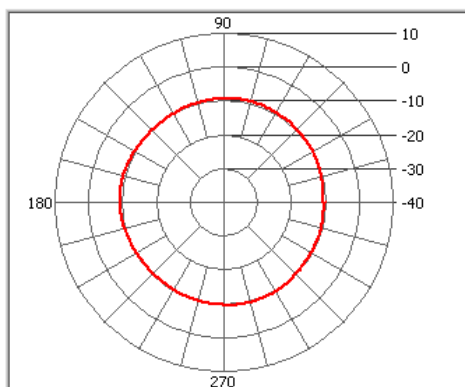
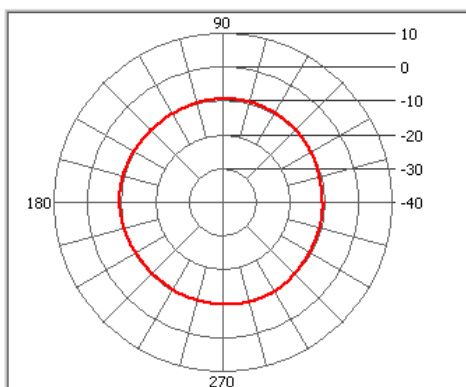



Cortec Technology Inc.

广东省东莞市长安镇振安路沙头段咸西工业区

Model : AN8921F-57 Antenna
Remark : H-Plane // V-Pol
Tested by : CORTEC Antenna 3D Lab // Zhao Yao Rong

Freq. (MHz)	1710	1730	1770	1800
Peak Gain (dBi)	-0.21	1.12	1.08	1.03
Peak Degree	347	151	284	346
AV Gain (dBi)	-0.8	0.21	0.63	0.36

Location: **Chamber**

Date: 2009/9/1

Time: 下午 07:07:36

Temperatuer (°C): 22.00

Humidity (%): 55.00

Approved by:

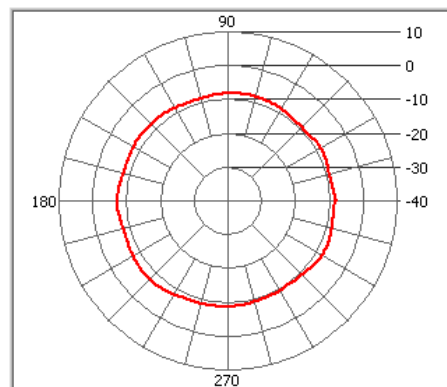
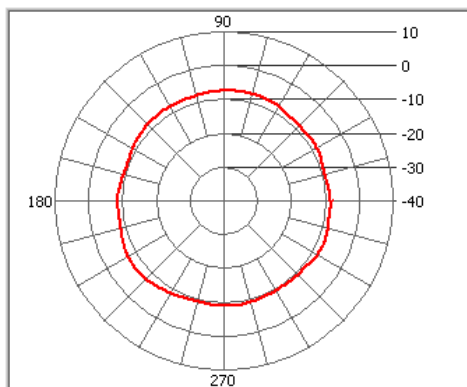
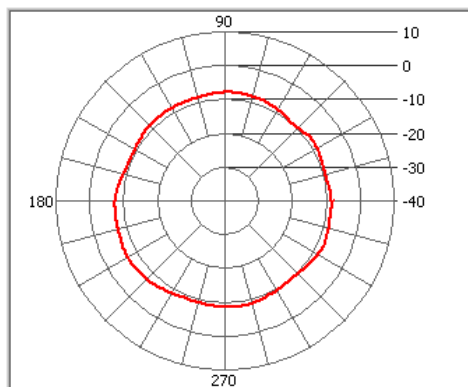
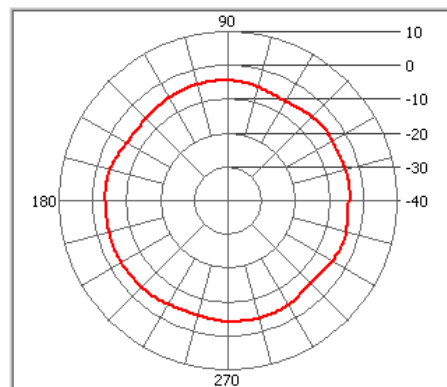
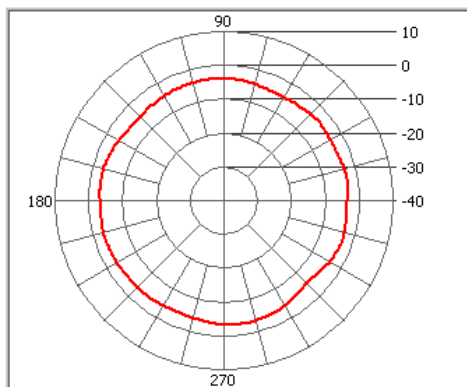
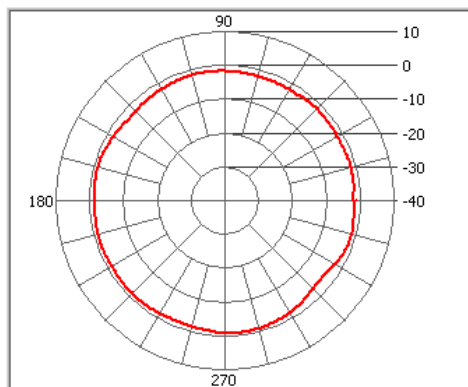
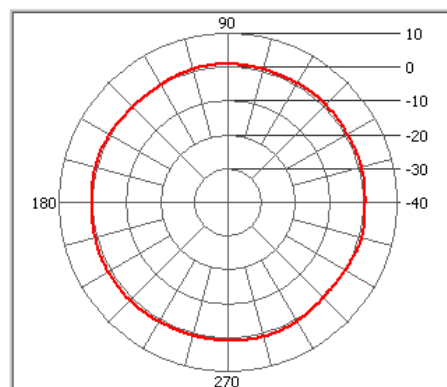
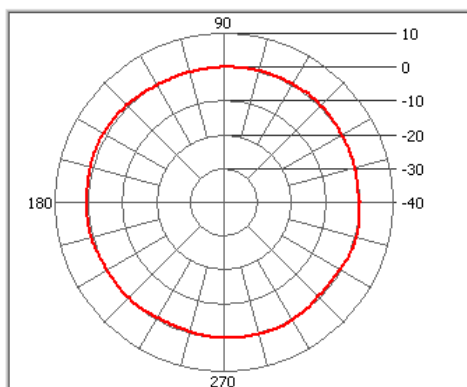
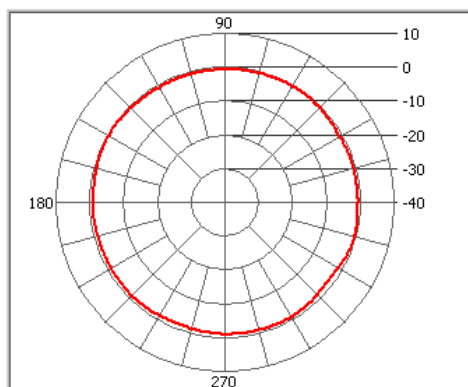

RoHS
Compatible

SIGN	DATE

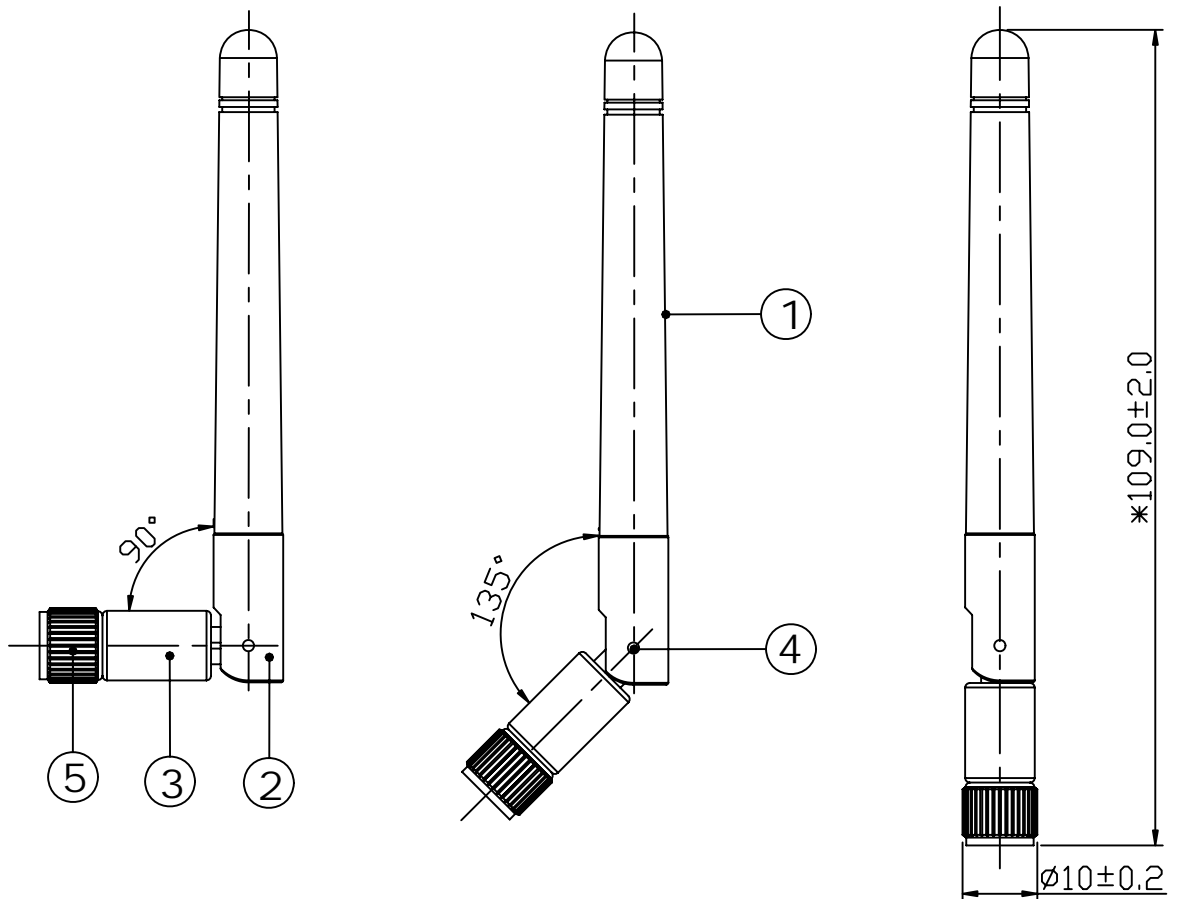

Noted :

1. Unmarked tolerance refer to standard tolerance please.
2. Taken* dimension is the important dimension.

5	R-SMA260-ZC8MNANT	SMA Male	Zn Alloy	Eleetrodeposition	1
4	R-AN01-1213Z	Pin	Cu	Plated Zn Black	2
3	R-AN57-01	Body-3	PA+ABS	Black	1
2	R-AN57-02	Body-2	PA+ABS	Black	1
1	R-AN57-03	Body-1	TPE	Black	1
NO.	Part Number	Description	Material	Finish	Q'ty

Invox System Group.	
Cor	
PART NAME: GSM	
PART NO.: AN892	
APPROVED BY	
Grant	
2009.08.27	

Part Number : AN8921F-5701SM	Revision : A
Name: AP Antenna	Customer : ALL

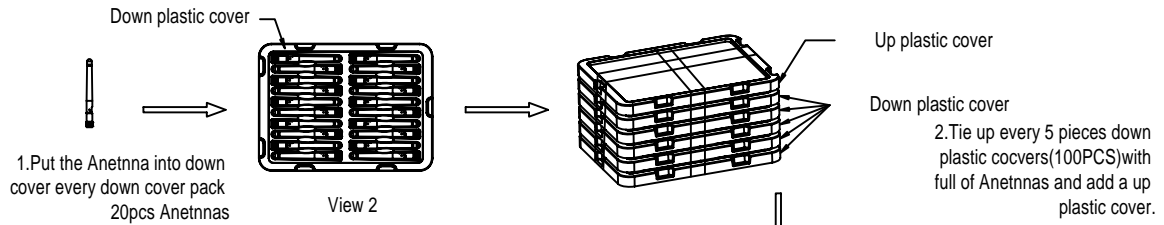

3. Put 10 bundles products (1000pcs) into out Carton .

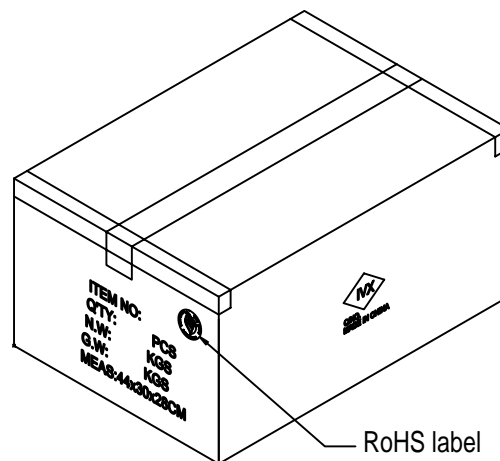
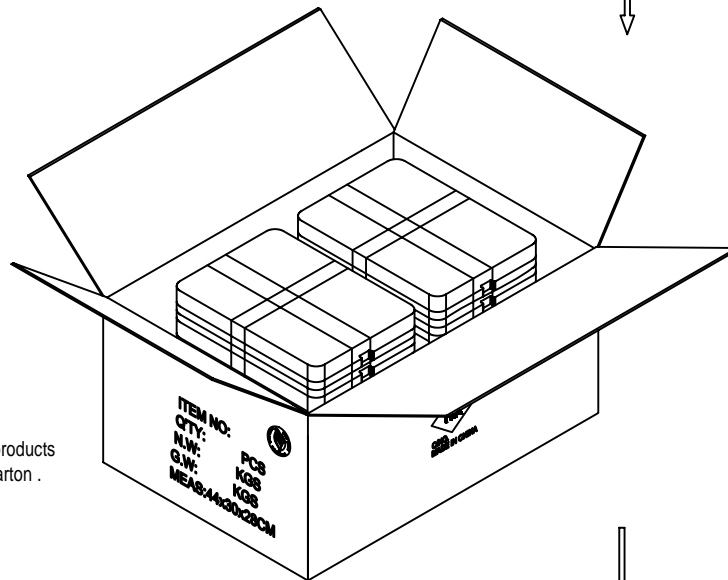

4. Pack the out Carton, paste RoHS label on the out Carton.

SGS 台灣網站 → http://twap.sgs.com/sgsrsts/chn/cheres_tw.asp
 SGS 大陸網站 → http://rsts.cn.sgs.com/chn/cheres_cn.asp
 SGS 韓國網站 → http://rohs.kr.sgs.com/sgsrsts/en/cheres_en.asp

請輸入以下報告正確資料及檢查碼以便查核

1. 報告編號
2. 報告日期 (YYYY/MM/DD)
3. 產品名稱 (輸入前 10 個字不含空白)
4. 圖示檢查碼 (依指示畫面)

物料中RoHS對象物質含量調查表

物料名稱：AN8921F-5701SM

序號	物料型號	物料各構成名稱	各構成物 料的材質	測試報告裡RoHS對應物質測試結果						檢測報告編號
				Cd	Pb	Hg	Cr(VI)	PBBs	PBDEs	
1	R-AN57-03	Body1	TPE	N.D.	N.D.	N.D.	N.D.	N.D.	N.D.	CE/2009/12273
2	R-AN57-02 R-AN57-01	Body2 Body3	PA+ABS	N.D.	N.D.	N.D.	N.D.			F690501/LF-CTSAYAA09-08
3	R-AN01-1213Z	Pin	銅	12	31199	N.D.	Negative			CANEC0805640301
4	R-SMA260-ZC8MNANT	SMA Male	鋅合金	11	26	N.D.	Negative	N.D.	N.D.	CANEC0900090808
5	R-AN44335375S	Tube	銅	12	31199	N.D.	Negative			CANEC0805640301
6	R-RG-178U	Cable RG178	外皮 (FEP)	N.D.	N.D.	N.D.	N.D.	N.D.	N.D.	SH9139605/CHEM
7			PTFE	N.D.	N.D.	N.D.	N.D.	N.D.	N.D.	SH9139605/CHEM
8			鍍銀銅絲	N.D.	N.D.	N.D.	Negative			SH9139605/CHEM
9			鍍銀銅線	N.D.	N.D.	N.D.	Negative			SH9139605/CHEM
10	R-ANS08-50-265	Spring	碳鋼線	N.D.	N.D.	N.D.	Negative			CANEC0900380202

根據測試報告如實填寫鉛、鎘、汞、六價鉻、PBBs和PBDEs六項禁用物質的含量
 包裝材料中鉛、鎘、汞、六價鉻總含量不超過100ppm，鎘的允許濃度為5ppm

TPE Datasheet

物性項目 Property	單位 Unit	ASTM 試驗法 Test Method	TPE
比重 Specific Gravity	---	D792	0.88
模具收縮率 Shrinkage	%	D955	0.8-2.5
斷裂拉伸強度 Tensile Strength	Kg/ cm ³	D638	3.1
扭曲強度 Flexural Strength	Kg/ cm ³	D790	---
衝擊強度缺口 23°C Impact Strength	Kg om/om	D256	---
硬度 Hardness	A Shore	---	13
熱變形溫度 0.45 MPa Heat Deflection Temp.	°C	D648	80
熔融指數 Melt Flow Index	G/ min ²	D1238	10
燃燒性 Flammability	---	UL94	HB
<p>Testing Data from</p> <p>東莞市合春塑料有限公司 Tel:86-0769-2774772</p> <p>台灣大雅國際股份有限公司 Tel:886-02-27775232</p>			

測試報告 Test Report

號碼(No.): CE/2009/12273

日期(Date): 2009/01/16

頁數(Page): 1 of 6

長春人造樹脂廠股份有限公司



CHANG CHUN PLASTICS CO., LTD.

(CHANG CHUN CHEMICAL (ZHANGZHOU) CO., LTD.)

台北市中山區松江路301號7樓

7TH FL., 301, SONG KIANG ROAD, TAIPEI, TAIWAN, R. O. C.

以下測試樣品係由客戶送樣，且由客戶聲稱並經客戶確認如下 (The following samples was/were submitted and identified by/on behalf of the client as):

樣品名稱(Sample Description) : THERMOPLASTIC POLYESTER ELASTOMER, TPEE
 樣品型號(Style/Item No.) : TPEE (1140LH, 1140XH, 1143LH, 1143XH, 1155LL, 1163LL, 1172LL, 1177LL)
 收件日期(Sample Receiving Date) : 2009/01/12
 測試期間(Testing Period) : 2009/01/12 TO 2009/01/16

=====
測試需求(Test Requested) : 參照 RoHS 2002/95/EC 及其修定指令要求. (In accordance with the RoHS Directive 2002/95/EC, and its amendment directives).

測試方法(Test Method) : 參考 IEC 62321: 2008 方法檢測. (With reference to IEC 62321: 2008. Procedures for the Determination of Levels of Regulated Substances in Electrotechnical Products).
 (1) 用感應耦合電漿原子發射光譜儀檢測鎘含量. / Determination of Cadmium by ICP-AES.
 (2) 用感應耦合電漿原子發射光譜儀檢測鉛含量. / Determination of Lead by ICP-AES.
 (3) 用感應耦合電漿原子發射光譜儀檢測汞含量. / Determination of Mercury by ICP-AES.
 (4) 用 UV-VIS 檢測六價鉻含量. / Determination of Hexavalent Chromium by UV/Vis Spectrometry.
 (5) 以氣相層析儀/質譜儀檢測多溴聯苯和多溴聯苯醚含量. / Determination of PBB and PBDE by GC/MS.

測試結果(Test Results) : 請見下一頁 (Please refer to next pages).

Chenyu Kung / Operation Manager
 Signed for and on behalf of
SGS TAIWAN LTD.
 Chemical Laboratory – Taipei

Unless otherwise stated the results shown in this test report refer only to the sample(s) tested. This test report cannot be reproduced, except in full, without prior written permission of the Company. 除非另有說明，此報告結果僅對測試之樣品負責。本報告未經本公司書面許可，不可部分複製。
 This Test Report is issued by the Company under its General Conditions of Service printed overleaf or available on request and accessible at http://www.sgs.com/terms_and_conditions.htm. Attention is drawn to the limitation of liability, indemnification and jurisdiction issues defined therein. Any holder of this Test Report is advised that information contained hereon reflects the Company's findings at the time of its intervention only and within the limits of Client's instructions, if any. The Company's sole responsibility is to its Client and this document does not exonerate parties to a transaction from exercising all their rights and obligations under the transaction documents. Any unauthorized alteration, forgery or falsification of the content or appearance of this document is unlawful and offenders may be prosecuted to the fullest extent of the law.

測試報告 Test Report

號碼(No.): CE/2009/12273

日期(Date): 2009/01/16

頁數(Page): 2 of 6

長春人造樹脂廠股份有限公司

CHANG CHUN PLASTICS CO., LTD.

(CHANG CHUN CHEMICAL (ZHANGZHOU) CO., LTD.)

台北市中山區松江路301號7樓

7TH FL., 301, SONG KIANG ROAD, TAIPEI, TAIWAN, R. O. C.



測試結果(Test Results) 單位(Unit): mg/kg

測試項目 (Test Items)	測試方法 Method (Refer to)	結果 (Result)	方法偵測 極限值 (MDL)
		No.1	
鎘 / Cadmium (Cd)	(1)	n.d.	2
鉛 / Lead (Pb)	(2)	n.d.	2
汞 / Mercury (Hg)	(3)	n.d.	2
六價鉻 / Hexavalent Chromium Cr(VI) by alkaline extraction	(4)	n.d.	2
多溴聯苯總和 / Sum of PBBs	(5)	n.d.	-
一溴聯苯 / Monobromobiphenyl		n.d.	5
二溴聯苯 / Dibromobiphenyl		n.d.	5
三溴聯苯 / Tribromobiphenyl		n.d.	5
四溴聯苯 / Tetrabromobiphenyl		n.d.	5
五溴聯苯 / Pentabromobiphenyl		n.d.	5
六溴聯苯 / Hexabromobiphenyl		n.d.	5
七溴聯苯 / Heptabromobiphenyl		n.d.	5
八溴聯苯 / Octabromobiphenyl		n.d.	5
九溴聯苯 / Nonabromobiphenyl		n.d.	5
十溴聯苯 / Decabromobiphenyl		n.d.	5
多溴聯苯醚總和 / Sum of PBDEs		n.d.	-
一溴聯苯醚 / Monobromodiphenyl ether		n.d.	5
二溴聯苯醚 / Dibromodiphenyl ether		n.d.	5
三溴聯苯醚 / Tribromodiphenyl ether		n.d.	5
四溴聯苯醚 / Tetrabromodiphenyl ether		n.d.	5
五溴聯苯醚 / Pentabromodiphenyl ether		n.d.	5
六溴聯苯醚 / Hexabromodiphenyl ether		n.d.	5
七溴聯苯醚 / Heptabromodiphenyl ether		n.d.	5
八溴聯苯醚 / Octabromodiphenyl ether		n.d.	5
九溴聯苯醚 / Nonabromodiphenyl ether	n.d.	5	
十溴聯苯醚 / Decabromodiphenyl ether	n.d.	5	

Unless otherwise stated the results shown in this test report refer only to the sample(s) tested. This test report cannot be reproduced, except in full, without prior written permission of the Company.
除非另有說明，此報告結果僅對測試之樣品負責。本報告未經本公司書面許可，不可部分複製。

This Test Report is issued by the Company under its General Conditions of Service printed overleaf or available on request and accessible at http://www.sgs.com/terms_and_conditions.htm. Attention is drawn to the limitation of liability, indemnification and jurisdiction issues defined therein. Any holder of this Test Report is advised that information contained hereon reflects the Company's findings at the time of its intervention only and within the limits of Client's instructions, if any. The Company's sole responsibility is to its Client and this document does not exonerate parties to a transaction from exercising all their rights and obligations under the transaction documents. Any unauthorized alteration, forgery or falsification of the content or appearance of this document is unlawful and offenders may be prosecuted to the fullest extent of the law.

測試報告 Test Report

號碼(No.): CE/2009/12273

日期(Date): 2009/01/16

頁數(Page): 3 of 6

長春人造樹脂廠股份有限公司

CHANG CHUN PLASTICS CO., LTD.

(CHANG CHUN CHEMICAL (ZHANGZHOU) CO., LTD.)

台北市中山區松江路301號7樓

7TH FL., 301, SONG KIANG ROAD, TAIPEI, TAIWAN, R. O. C.



測試部位描述 (TEST PART DESCRIPTION):

NO.1 : 白色塑膠粒 (WHITE PLASTIC PELLETS)

備註(Note):

1. mg/kg = ppm ; 0.1wt% = 1000ppm
2. n.d. = Not Detected (未檢出)
3. MDL = Method Detection Limit (方法偵測極限值)
4. "-" = Not Regulated (無規格值)

Unless otherwise stated the results shown in this test report refer only to the sample(s) tested. This test report cannot be reproduced, except in full, without prior written permission of the Company. 除非另有說明，此報告結果僅對測試之樣品負責。本報告未經本公司書面許可，不可部分複製。

This Test Report is issued by the Company under its General Conditions of Service printed overleaf or available on request and accessible at http://www.sgs.com/terms_and_conditions.htm. Attention is drawn to the limitation of liability, indemnification and jurisdiction issues defined therein. Any holder of this Test Report is advised that information contained hereon reflects the Company's findings at the time of its intervention only and within the limits of Client's instructions, if any. The Company's sole responsibility is to its Client and this document does not exonerate parties to a transaction from exercising all their rights and obligations under the transaction documents. Any unauthorized alteration, forgery or falsification of the content or appearance of this document is unlawful and offenders may be prosecuted to the fullest extent of the law.

測試報告 Test Report

號碼(No.): CE/2009/12273

日期(Date): 2009/01/16

頁數(Page): 4 of 6

長春人造樹脂廠股份有限公司

CHANG CHUN PLASTICS CO., LTD.

(CHANG CHUN CHEMICAL (ZHANGZHOU) CO., LTD.)

台北市中山區松江路301號7樓

7TH FL., 301, SONG KIANG ROAD, TAIPEI, TAIWAN, R. O. C.



- 1) 根據以下的流程圖之條件，樣品已完全溶解。(六價鉻測試方法除外) / These samples were dissolved totally by pre-conditioning method according to below flow chart. (Cr⁶⁺ test method excluded)
- 2) 測試人員：楊登偉 / Name of the person who made measurement: Climbgreat Yang
- 3) 測試負責人：張啓興 / Name of the person in charge of measurement: Troy Chang

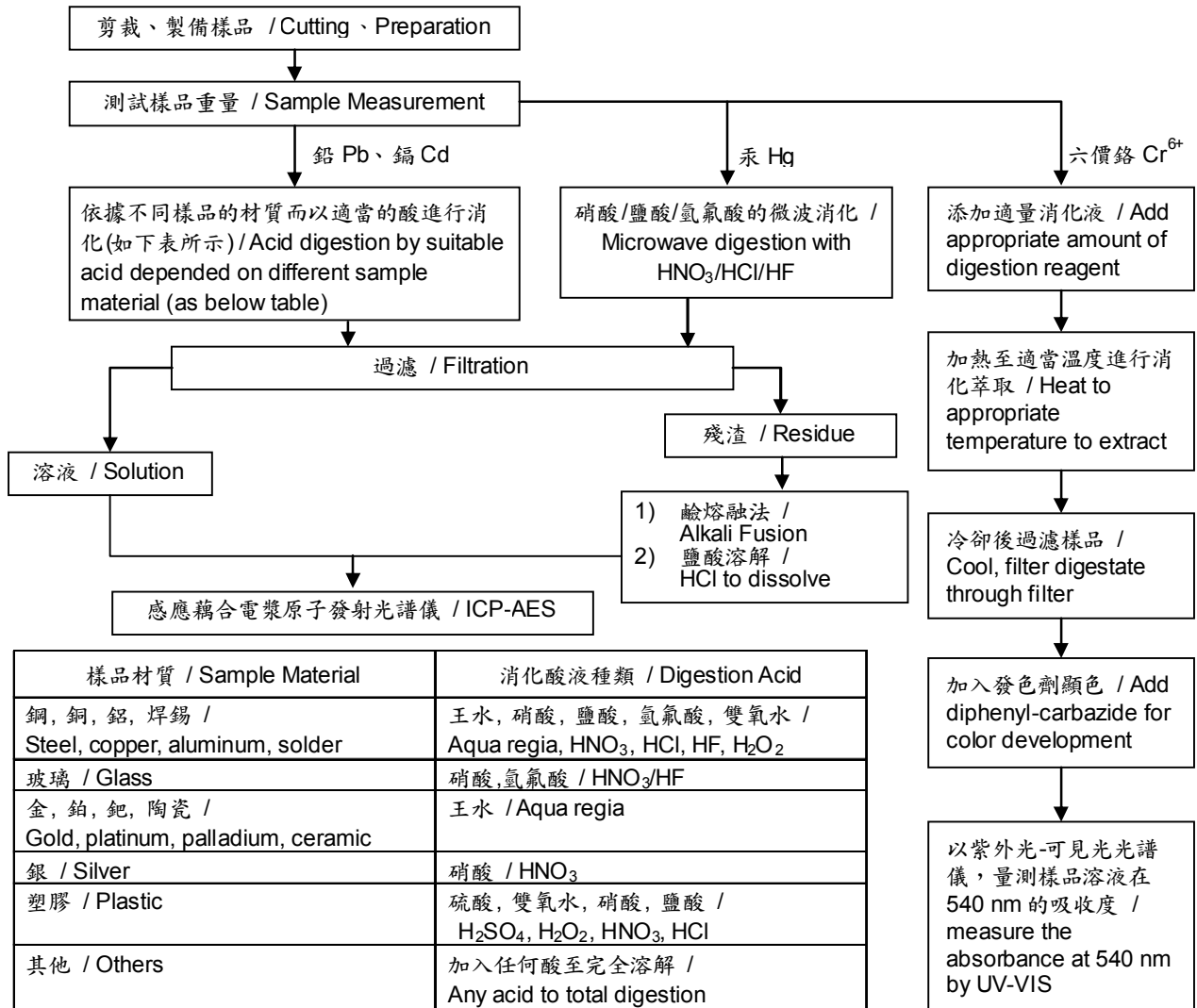

Unless otherwise stated the results shown in this test report refer only to the sample(s) tested. This test report cannot be reproduced, except in full, without prior written permission of the Company. 除非另有說明，此報告結果僅對測試之樣品負責。本報告未經本公司書面許可，不可部分複製。

This Test Report is issued by the Company under its General Conditions of Service printed overleaf or available on request and accessible at http://www.sgs.com/terms_and_conditions.htm. Attention is drawn to the limitation of liability, indemnification and jurisdiction issues defined therein. Any holder of this Test Report is advised that information contained herein reflects the Company's findings at the time of its intervention only and within the limits of Client's instructions, if any. The Company's sole responsibility is to its Client and this document does not exonerate parties to a transaction from exercising all their rights and obligations under the transaction documents. Any unauthorized alteration, forgery or falsification of the content or appearance of this document is unlawful and offenders may be prosecuted to the fullest extent of the law.

測試報告 Test Report

號碼(No.): CE/2009/12273

日期(Date): 2009/01/16

頁數(Page): 5 of 6

長春人造樹脂廠股份有限公司

CHANG CHUN PLASTICS CO., LTD.

(CHANG CHUN CHEMICAL (ZHANGZHOU) CO., LTD.)

台北市中山區松江路301號7樓

7TH FL., 301, SONG KIANG ROAD, TAIPEI, TAIWAN, R. O. C.



多溴聯苯/多溴聯苯醚分析流程圖 / PBB/PBDE analytical FLOW CHART

- 1) 測試人員：翁賜彬 / Name of the person who made measurement: Roman Wong
- 2) 測試負責人：陳新智 / Name of the person in charge of measurement: Shinjyh Chen

初次測試程序 / First testing process ———▶

選擇性篩檢程序 / Optional screen process▶

確認程序 / Confirmation process - - - -▶

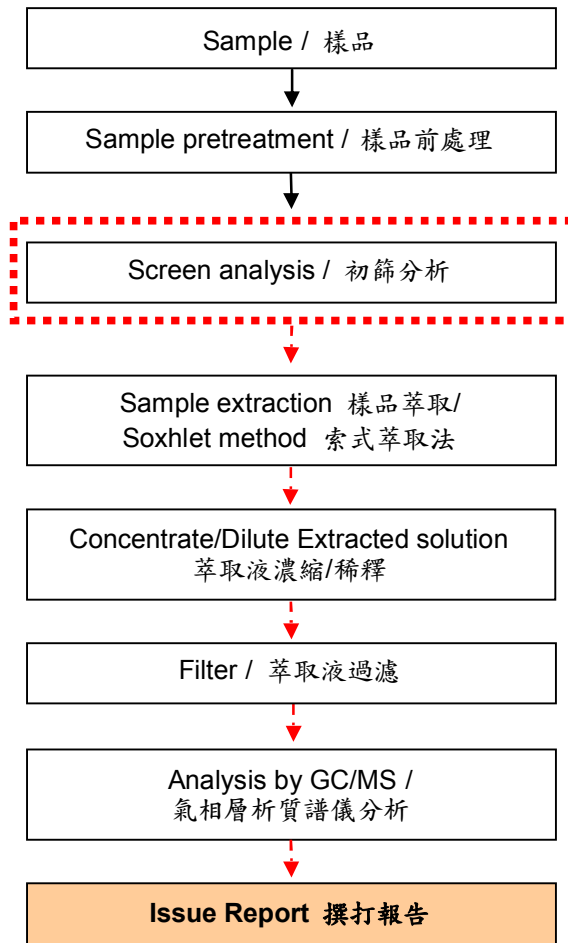

Unless otherwise stated the results shown in this test report refer only to the sample(s) tested. This test report cannot be reproduced, except in full, without prior written permission of the Company. 除非另有說明，此報告結果僅對測試之樣品負責。本報告未經本公司書面許可，不可部分複製。

This Test Report is issued by the Company under its General Conditions of Service printed overleaf or available on request and accessible at http://www.sgs.com/terms_and_conditions.htm. Attention is drawn to the limitation of liability, indemnification and jurisdiction issues defined therein. Any holder of this Test Report is advised that information contained hereon reflects the Company's findings at the time of its intervention only and within the limits of Client's instructions, if any. The Company's sole responsibility is to its Client and this document does not exonerate parties to a transaction from exercising all their rights and obligations under the transaction documents. Any unauthorized alteration, forgery or falsification of the content or appearance of this document is unlawful and offenders may be prosecuted to the fullest extent of the law.

測試報告 Test Report

號碼(No.): CE/2009/12273

日期(Date): 2009/01/16

頁數(Page): 6 of 6

長春人造樹脂廠股份有限公司

CHANG CHUN PLASTICS CO., LTD.

(CHANG CHUN CHEMICAL (ZHANGZHOU) CO., LTD.)

台北市中山區松江路301號7樓

7TH FL., 301, SONG KIANG ROAD, TAIPEI, TAIWAN, R. O. C.

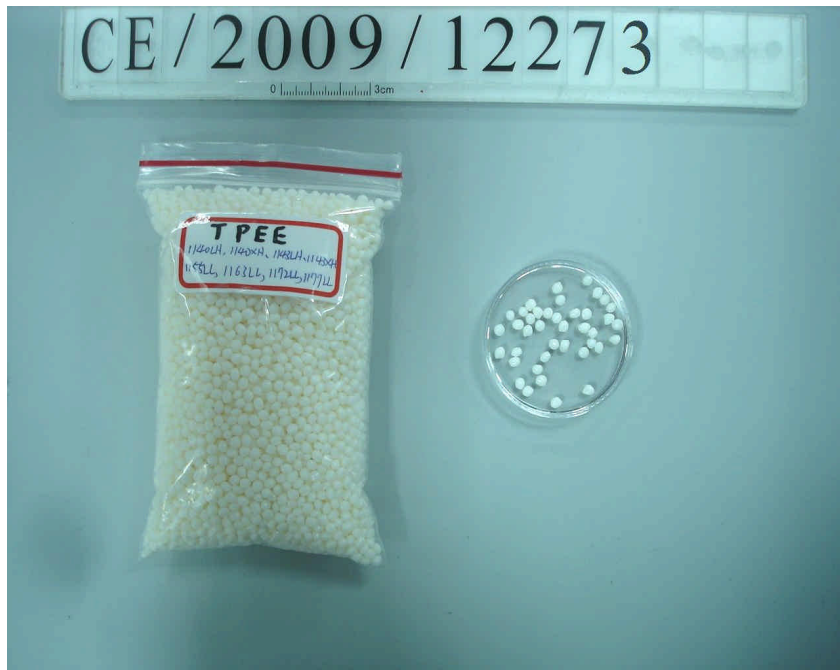

** 報告結尾(End of Report) **

Unless otherwise stated the results shown in this test report refer only to the sample(s) tested. This test report cannot be reproduced, except in full, without prior written permission of the Company. 除非另有說明，此報告結果僅對測試之樣品負責。本報告未經本公司書面許可，不可部分複製。

This Test Report is issued by the Company under its General Conditions of Service printed overleaf or available on request and accessible at http://www.sgs.com/terms_and_conditions.htm. Attention is drawn to the limitation of liability, indemnification and jurisdiction issues defined therein. Any holder of this Test Report is advised that information contained hereon reflects the Company's findings at the time of its intervention only and within the limits of Client's instructions, if any. The Company's sole responsibility is to its Client and this document does not exonerate parties to a transaction from exercising all their rights and obligations under the transaction documents. Any unauthorized alteration, forgery or falsification of the content or appearance of this document is unlawful and offenders may be prosecuted to the fullest extent of the law.



Rhodia Polyamide Co., Ltd.

RHODIA POLYAMIDE CO., LTD.
3 FL. KANGNAM BLDG. 1321-1
SEOCHO-DONG SEOCHO-KU
SEOUL 137-070
KOREA

TAIWAN YOSON CO., LTD
10F-1 NO.68 , INDUSTRIAL DIST.1RD
HSI TUN DIST. TAICHUNG TAIWAN ROC
411 TAICHUNG
TAIWAN

Manufacturing Plant
RHODIA POLYAMIDE ONSAN PLANT
WONSAN-RI, ONSAN-EUP, ULJU-KUN
689-892, ULSAN-SI
SOUTH KOREA

Certificate of analysis

Date
15.04.2008
L/C order n /Date

Delivery item/Date
80950449 900001 / 14.04.2008
Order item/Date
623022 000010
Customer
75102
Contract number

Material: Our / Your reference
77474 TECHNYL ALLOY KC 226 NATURAL 25 KG BAG(S) /

The dispatched material conforms to agreed requirements

Batch 0810307 / Quantity 4,300 KG

Characteristic	Unit	Value	Limit Lower	Limit upper
Moisture content ISO 15512	%	0.036	0.000	0.200
Melt flow index ISO 1133 (235 C; 2,16 kg)	g/10mn	3.1	1.0	15.0

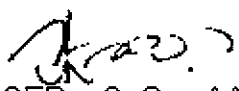
CHECKED BY: 
QUALITY MANAGER – OnSan AA/EP/POLY
(AA) Tel (82.52) 231-0800 / Fax 238-0015
(EP) Tel (82.52) 231-0900 / Fax 231-0993
(Poly) Tel (82. 52) 240-0700 / Fax 237-6525



Test Report No. F690501/LF-CTSAYAA09-08509C

Issued Date: March 30, 2009

Page 1 of 5

To: RHODIA POLYAMIDE CO., LTD.
1321-1
Seocho-dong
Seocho-gu
SEOUL
Korea

The following merchandise was submitted and identified by the client as :

Product Name : KC 226 NATURAL
SGS File No. : AYAA09-08509C
Received Date : March 25, 2009
Test Performing Date : March 26, 2009
Test Performed : SGS Testing Korea tested the sample(s) selected by applicant with following results
Test Results : For further details, please refer to following page(s)

Pluto Kim
Cindy Park
Jinee Song/ Testing Person

SGS Testing Korea Co. Ltd.

Jeff Jang / Chemical Lab Mgr

This document is issued by the Company subject to the General Conditions of Service printed on the back of this report or available at www.sgs.com for electronic format documents, subject to Terms and Conditions for Electronic Documents at www.sgs.com/etcdocuments. The Company is not responsible for the behavior of third parties, intermediaries and translators using this report. The holder of this document is advised that information contained herein reflects the Company's findings at the time of its issuance only and is valid on the basis of Client's description of the sample. The Company's sole responsibility is to the Client and the document can not constitute parties to a transaction from accepting it. It is the Client's obligation under the transaction agreement. This document cannot be reproduced except by mail without prior written approval of the Company. Any unauthorized alteration, deletion or distribution of the content or appearance of this document is strictly prohibited and may be punishable by law. The Client shall be responsible for the results shown in this report only if the sampled samples are not sampled as ordered by the client.

Sample No. : AYAA09-08509C.001
Sample Description : KC 226 NATURAL
Item No./Part No. : N/A
Comments : Material is plastic.

Heavy Metals

Test Items	Unit	Test Method	MDL	Results
Cadmium (Cd)	mg/kg	With reference to IEC 62321:2008, ICP	0.5	N.D.
Lead (Pb)	mg/kg	With reference to IEC 62321:2008, ICP	5	N.D.
Mercury (Hg)	mg/kg	With reference to IEC 62321:2008, ICP	2	N.D.
Hexavalent Chromium (Cr VI)	mg/kg	With reference to IEC 62321:2008, UV-VIS	1	N.D.

Halogen Contents

Test Items	Unit	Test Method	MDL	Results
Bromine(Br)	mg/kg	BS EN 14582:2007 , IC	30	N.D.
Chlorine(Cl)	mg/kg	BS EN 14582:2007 , IC	30	N.D.

- NOTE:
- (1) N.D. = Not detected.(<MDL)
 - (2) mg/kg = ppm
 - (3) MDL = Method Detection Limit
 - (4) - = No regulation
 - (5) ** = Qualitative analysis (No Unit)
 - (6) * = Boiling-water-extraction:
 Negative = Absence of CrVI coating
 Positive = Presence of CrVI coating; the detected concentration in boiling-water-extraction solution is equal or greater than 0.02 mg/kg with 50 cm² sample surface area.

The accuracy is based on the Company policy to be based on the conditions of service unless otherwise stated or specified in the contract. The Company is not responsible for the results of the analysis if the sample is not representative of the material. The Company is not responsible for the results of the analysis if the sample is not representative of the material. The Company is not responsible for the results of the analysis if the sample is not representative of the material. The Company is not responsible for the results of the analysis if the sample is not representative of the material.

Picture of Sample as Received:



- NOTE:
- (1) N.D. = Not detected.(\leq MDL)
 - (2) mg/kg = ppm
 - (3) MDL = Method Detection Limit
 - (4) - = No regulation
 - (5) ** = Qualitative analysis (No Unit)
 - (6) * = Boiling-water-extraction:
 Negative = Absence of CrVI coating
 Positive = Presence of CrVI coating; the detected concentration in boiling-water-extraction solution is equal or greater than 0.02 mg/kg with 50 cm² sample surface area.

The accuracy is based on the Company's ability to be directly correlated to the National Institute of Standards and Technology (NIST) or other recognized reference materials. The accuracy of the results is subject to the quality of the sample and the quality of the reagents used. The Company is not responsible for the results of the analysis if the sample is not properly prepared or if the sample is not representative of the material being tested. The Company is not responsible for the results of the analysis if the sample is not properly stored or if the sample is not properly labeled. The Company is not responsible for the results of the analysis if the sample is not properly handled or if the sample is not properly analyzed. The Company is not responsible for the results of the analysis if the sample is not properly reported or if the sample is not properly archived.

Testing Flow Chart for RoHS: Cd/Pb/Hg/Cr⁶⁺ Testing

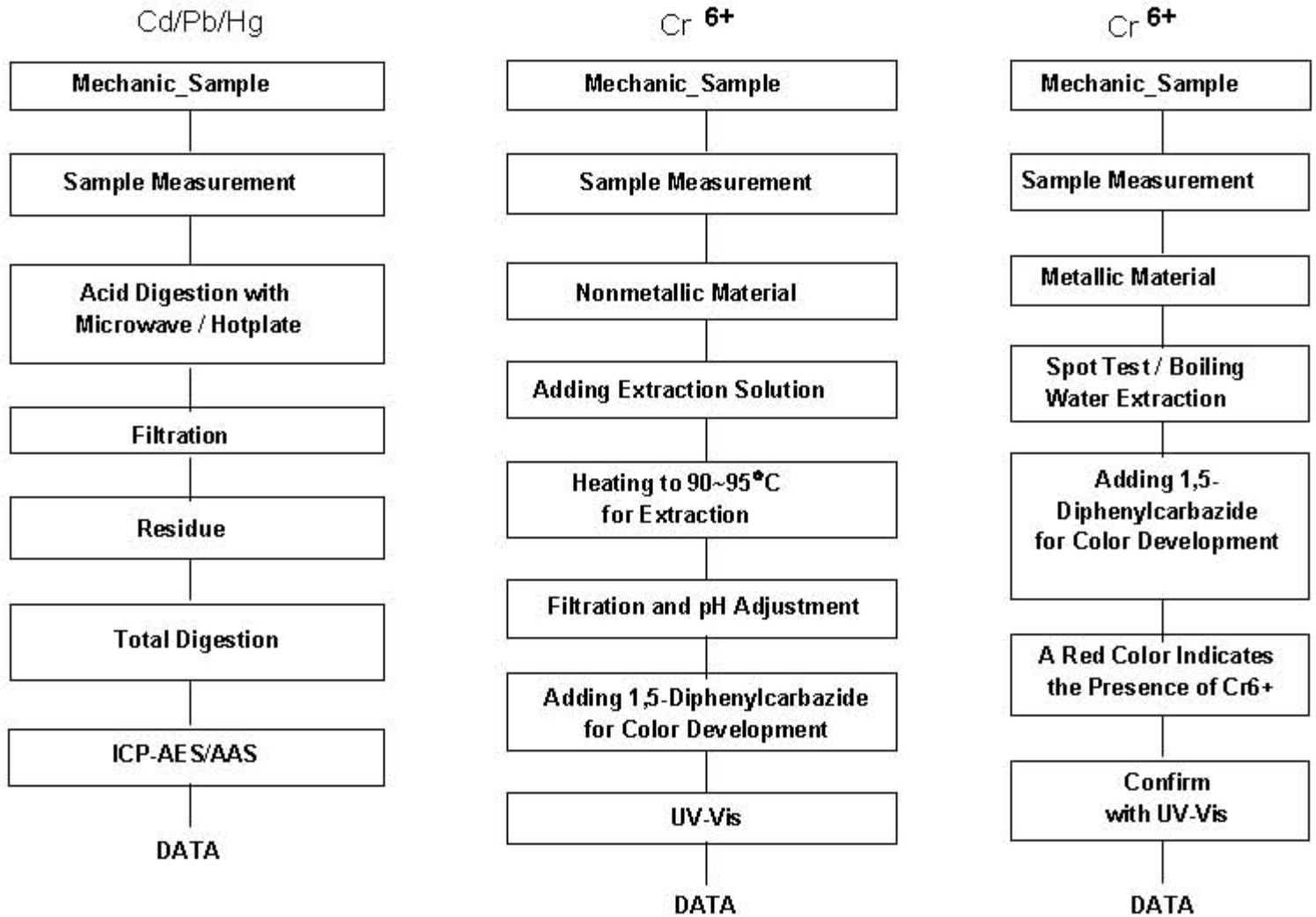

The samples were dissolved totally by pre-conditioning method according to above flow chart for Cd,Pb,Hg.

Operator Dami Yeom

Section Chief Jeff Jang

- NOTE:
- (1) N.D. = Not detected. (<MDL)
 - (2) mg/kg = ppm
 - (3) MDL = Method Detection Limit
 - (4) - = No regulation
 - (5) ** = Qualitative analysis (No Unit)
 - (6) * = Boiling-water-extraction:
 Negative = Absence of CrVI coating
 Positive = Presence of CrVI coating; the detected concentration in boiling-water-extraction solution is equal or greater than 0.02 mg/kg with 50 cm² sample surface area.

The accuracy is based by the Company subject to the General Conditions of Service printed on each certificate or report or available at www.sgs.com and www.sgs.com. The Company is not responsible for the accuracy of the results of the analysis if the samples are not properly prepared or if the samples are not representative of the material. The Company is not responsible for the accuracy of the results of the analysis if the samples are not properly prepared or if the samples are not representative of the material. The Company is not responsible for the accuracy of the results of the analysis if the samples are not properly prepared or if the samples are not representative of the material.

Flow Chart for Halogen Test

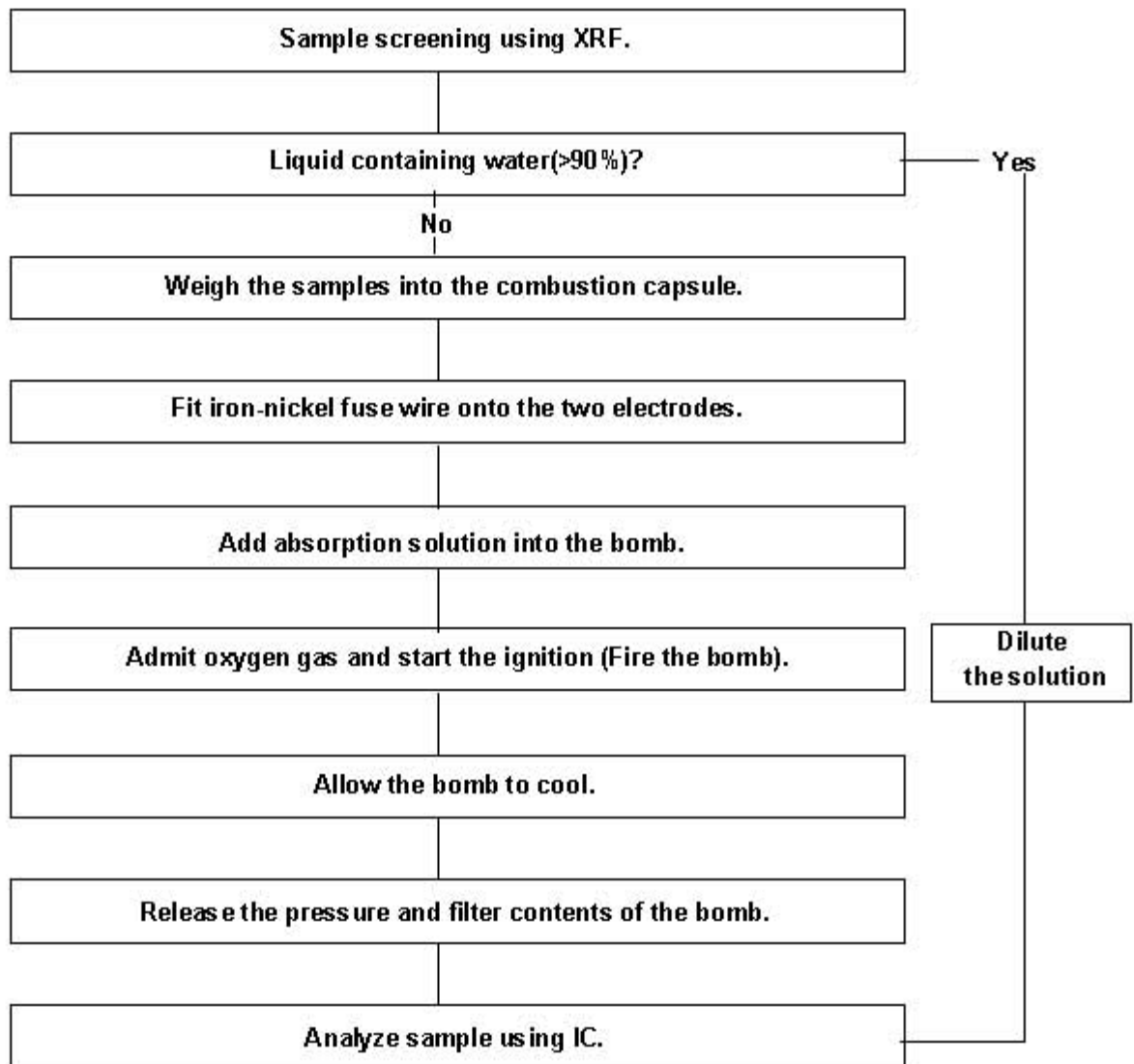

*** End ***

- NOTE:
- (1) N.D. = Not detected.(<MDL)
 - (2) mg/kg = ppm
 - (3) MDL = Method Detection Limit
 - (4) - = No regulation
 - (5) ** = Qualitative analysis (No Unit)
 - (6) * = Boiling-water-extraction:
 Negative = Absence of CrVI coating
 Positive = Presence of CrVI coating; the detected concentration in boiling-water-extraction solution is equal or greater than 0.02 mg/kg with 50 cm2 sample surface area.

The document is issued by the Company subject to the General Conditions of Service printed on each report, available on request or accessible at www.sgs.com or www.sgs.com/eng for electronic format documents, subject to Terms and Conditions for Electronic Documents at www.sgs.com/eng/electronic_documents.htm. The Company is not liable for the accuracy of the information provided in this report unless it is proven that the Company has acted with due care and diligence. The Company is not liable for the accuracy of the information provided in this report unless it is proven that the Company has acted with due care and diligence. The Company is not liable for the accuracy of the information provided in this report unless it is proven that the Company has acted with due care and diligence. The Company is not liable for the accuracy of the information provided in this report unless it is proven that the Company has acted with due care and diligence.



SHIYANG (ZHONG SHAN) METAL PRODUCTS

世扬金属制品有限公司

TEST CERTIFICATE

材质证明书



CLIENT 客户	天诚							cert 证
name article 品名	Brass							
LOT NO.	SIZE(MM)	OUTW GT	DESIGNATION	Cu(%)	Pb(%)	Fe(%)	Fe+Sn(%)	C
	STANDARD	(KG)	JISC3604	57~61	1.8~3.7	≤0.5	≤1.2	≤
7916	14.5 φ		JISC3604	58.92	2.986	0.446	0.971	0

兹证明本表所列产品,均依材料规格制造及试验,并符合规格之要求.

WE HEREBY CERTIFY THAT MATERIAL DESCRIBED HERE IN HAS BEEN MANUFACTURED
RESULTS IN ACCORDANCE WITH THE REQUIREMENT OF THE ABOVE MATERIAL SPECIFIC

MANAGER: 曾敦毅

PABLE: 李玉奎

THE THREE INDUSTRIAL AREA NAN LANG TOWN ZHONG SHAN CITY
中国广东省中山市南朗镇第三工业区

TEL:0760-
E-Mail:sa

Test Report

No. CANEC0805640301

Date: 24 Oct 2008

Page 1 of 4

ZHONG SHAN SHI YANG METAL PRODUCT CO.,LTD
THE THIRD INDUSTRIAL AREA NANLANG TOWN ZHONG SHAN CITY GUANGDONG PROVINCE
CHINA

The following sample(s) was/were submitted and identified on behalf of the clients as :
Jis C3604 BD COPPER

SGS Job No. : 11354821 - SZ
Client Reference Information : LOT NO 1931
Date of Sample Received : 04 Sep 2008
Testing Period : 04 Sep 2008 - 10 Sep 2008

Test Requested : Selected test(s) as requested by client.
Test Method : Please refer to next page(s).
Test Results : Please refer to next page(s).

Signed for and on behalf of
SGS-CSTC Ltd.



Huang Fang, Sunny
Sr. Engineer

This document is issued by the Company under its General Conditions of Service printed overleaf or available on request and accessible at http://www.sgs.com/terms_and_conditions.htm. Attention is drawn to the limitation of liability, indemnification and jurisdiction issues defined therein. Any holder of this document is advised that information contained hereon reflects the Company's findings at the time of its intervention only and within the limits of Client's instructions, if any. The Company's sole responsibility is to its Client and this document does not exonerate parties to a transaction from exercising all their rights and obligations under the transaction documents. Any unauthorized alteration, forgery or falsification of the content or appearance of this document is unlawful and offenders may be prosecuted to the fullest extent of the law. Unless otherwise stated the results shown in this test report refer only to the sample(s) tested. This document cannot be reproduced except in full, without prior approval of the Company.

Test Report

No. CANEC0805640301

Date: 24 Oct 2008

Page 2 of 4

Test Results:

ID for specimen 1 : CAN08-056403.001
 Description for specimen 1 : Brassy metal rod

Heavy Metal(s)

Test Item(s)	Unit	Test Method (Reference)	Result	MDL
Cadmium (Cd)	mg/kg	IEC 62321/2nd CDV (111/95/CDV), ICP-OES	12	2
Lead (Pb)	mg/kg	IEC 62321/2nd CDV (111/95/CDV), ICP-OES	31199	2
Mercury (Hg)	mg/kg	IEC 62321/2nd CDV (111/95/CDV), ICP-OES	N.D.	2
Hexavalent Chromium (CrVI) by boiling water extraction	-	IEC 62321/2nd CDV (111/95/CDV), UV-Vis	Negative	◇

Note:

1. mg/kg = ppm
2. N.D. = Not Detected (< MDL)
3. MDL = Method Detection Limit
4. ◇ = Spot-Test:

Negative = Absence of CrVI coating, Positive = Presence of CrVI coating;
 (The tested sample should be further verified by boiling-water-extraction method if the spot test result is negative or cannot be confirmed.)

Boiling-water-extraction:

Negative = Absence of CrVI coating
 Positive = Presence of CrVI coating; the detected concentration in boiling-water-extraction solution is equal or greater than 0.02 mg/kg with 50 cm² sample surface area.

5. "-" = Not regulated

Remark: Results & photo(s) of this report refer to test report CANEC0804900401.

This document is issued by the Company under its General Conditions of Service printed overleaf or available on request and accessible at http://www.sgs.com/terms_and_conditions.htm. Attention is drawn to the limitation of liability, indemnification and jurisdiction issues defined therein. Any holder of this document is advised that information contained hereon reflects the Company's findings at the time of its intervention only and within the limits of Client's instructions, if any. The Company's sole responsibility is to its Client and this document does not exonerate parties to a transaction from exercising all their rights and obligations under the transaction documents. Any unauthorized alteration, forgery or falsification of the content or appearance of this document is unlawful and offenders may be prosecuted to the fullest extent of the law. Unless otherwise stated the results shown in this test report refer only to the sample(s) tested. This document cannot be reproduced except in full, without prior approval of the Company.

ATTACHMENTS

Testing Flow Chart

- 1) Name of the person who made measurement: Bowen Chen
- 2) Name of the person in charge of measurement: Adams Yu

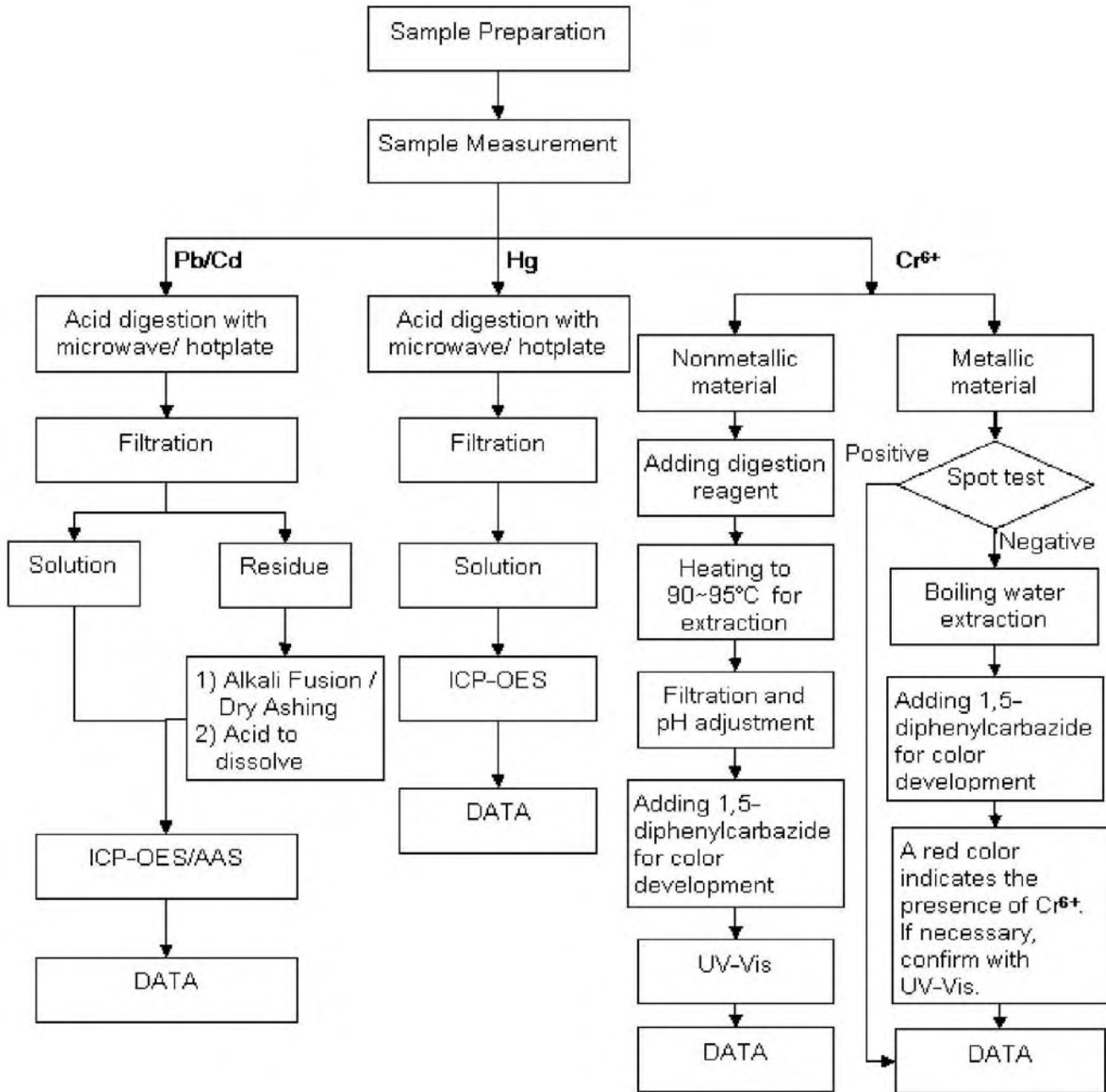

This document is issued by the Company under its General Conditions of Service printed overleaf or available on request and accessible at http://www.sgs.com/terms_and_conditions.htm. Attention is drawn to the limitation of liability, indemnification and jurisdiction issues defined therein. Any holder of this document is advised that information contained hereon reflects the Company's findings at the time of its intervention only and within the limits of Client's instructions, if any. The Company's sole responsibility is to its Client and this document does not exonerate parties to a transaction from exercising all their rights and obligations under the transaction documents. Any unauthorized alteration, forgery or falsification of the content or appearance of this document is unlawful and offenders may be prosecuted to the fullest extent of the law. Unless otherwise stated the results shown in this test report refer only to the sample(s) tested. This document cannot be reproduced except in full, without prior approval of the Company.

Sample photo:



SGS authenticate the photo on original report only

*** End of Report ***

This document is issued by the Company under its General Conditions of Service printed overleaf or available on request and accessible at http://www.sgs.com/terms_and_conditions.htm. Attention is drawn to the limitation of liability, indemnification and jurisdiction issues defined therein. Any holder of this document is advised that information contained hereon reflects the Company's findings at the time of its intervention only and within the limits of Client's instructions, if any. The Company's sole responsibility is to its Client and this document does not exonerate parties to a transaction from exercising all their rights and obligations under the transaction documents. Any unauthorized alteration, forgery or falsification of the content or appearance of this document is unlawful and offenders may be prosecuted to the fullest extent of the law. Unless otherwise stated the results shown in this test report refer only to the sample(s) tested. This document cannot be reproduced except in full, without prior approval of the Company.



117941-04

5/11/2008 12:15:51 PM

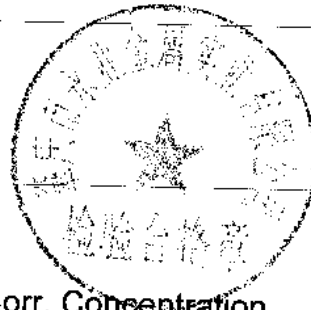

Method: Zn-50
Comment: Zamak 400/410/430

Type Corr. Concentration

5/11/2008 12:15:49 PM

Sample Name:
X2 B7

	Al %	Cd %	Cu %	Fe %	Mg %	Mn %	Ni %	Pb %
1	3.926	0.00095	0.351	0.0026	0.0337	< 0.00040	0.0062	0.0083
	Sn %	Si %	Cr %	Bi %	Zn %			
1	0.0020	0.0037	0.00099	< 0.00040	95.7			

测试报告

No. CANEC0900090808

日期: 2009年01月14日 第1页,共6页

肇庆市永业金属实业有限公司
中国广东省肇庆市高新区大旺工业园环市西路

以下测试之样品是由申请者所提供及确认:

锌合金锭ZN-3#

SGS工作编号 : 11535868 - GZ
SGS内部编号 : 8.8
样品接收日期 : 2009年01月08日
测试周期 : 2009年01月08日 - 2009年01月14日
测试要求 : 根据客户要求测试
测试方法 : 请参见下一页
测试结果 : 请参见下一页
结论 : 基于所送样品进行的测试, 测试结果与欧盟RoHS指令2002/95/EC以及后续修正指令的要求**相符**。

通标标准技术服务有限公司
授权签名



Huang Fang, Sunny
Sr. Engineer

This document is issued by the Company under its General Conditions of Service printed overleaf or available on request and accessible at http://www.sgs.com/terms_and_conditions.htm. Attention is drawn to the limitation of liability, indemnification and jurisdiction issues defined therein. Any holder of this document is advised that information contained hereon reflects the Company's findings at the time of its intervention only and within the limits of Client's instructions, if any. The Company's sole responsibility is to its Client and this document does not exonerate parties to a transaction from exercising all their rights and obligations under the transaction documents. Any unauthorized alteration, forgery or falsification of the content or appearance of this document is unlawful and offenders may be prosecuted to the fullest extent of the law. Unless otherwise stated the results shown in this test report refer only to the sample(s) tested. This document cannot be reproduced except in full, without prior approval of the Company.

测试报告

No. CANEC0900090808

日期: 2009年01月14日 第2页,共6页

测试结果:

样品1 ID : CAN09-000908.004
 样品1描述 : 银色金属

RoHS 指令 2002/95/EC

测试项目	单位	测试方法 (参考)	测试结果	MDL	限值
镉 (Cd)	毫克/千克	IEC 62321/2nd CDV (111/95/CDV), ICP-OES	11	2	100
铅 (Pb)	毫克/千克	IEC 62321/2nd CDV (111/95/CDV), ICP-OES	26	2	1000
汞 (Hg)	毫克/千克	IEC 62321/2nd CDV (111/95/CDV), ICP-OES	N.D.	2	1000
沸水萃取法测六价铬 (CrVI)	-	IEC 62321/2nd CDV (111/95/CDV), UV-Vis	Negative	◇	#
多溴联苯(PBBs)之和	毫克/千克	-	N.D.	-	1000
单溴联苯	毫克/千克	IEC 62321/2nd CDV (111/95/CDV), GC-MS	N.D.	5	
二溴联苯	毫克/千克	IEC 62321/2nd CDV (111/95/CDV), GC-MS	N.D.	5	
三溴联苯	毫克/千克	IEC 62321/2nd CDV (111/95/CDV), GC-MS	N.D.	5	
四溴联苯	毫克/千克	IEC 62321/2nd CDV (111/95/CDV), GC-MS	N.D.	5	
五溴联苯	毫克/千克	IEC 62321/2nd CDV (111/95/CDV), GC-MS	N.D.	5	
六溴联苯	毫克/千克	IEC 62321/2nd CDV (111/95/CDV), GC-MS	N.D.	5	
七溴联苯	毫克/千克	IEC 62321/2nd CDV (111/95/CDV), GC-MS	N.D.	5	
八溴联苯	毫克/千克	IEC 62321/2nd CDV (111/95/CDV), GC-MS	N.D.	5	
九溴联苯	毫克/千克	IEC 62321/2nd CDV (111/95/CDV), GC-MS	N.D.	5	
十溴联苯	毫克/千克	IEC 62321/2nd CDV (111/95/CDV), GC-MS	N.D.	5	
多溴二苯醚(PBDEs)之和	毫克/千克	-	N.D.	-	1000
单溴二苯醚	毫克/千克	IEC 62321/2nd CDV (111/95/CDV), GC-MS	N.D.	5	
二溴二苯醚	毫克/千克	IEC 62321/2nd CDV (111/95/CDV), GC-MS	N.D.	5	
三溴二苯醚	毫克/千克	IEC 62321/2nd CDV (111/95/CDV), GC-MS	N.D.	5	
四溴二苯醚	毫克/千克	IEC 62321/2nd CDV (111/95/CDV), GC-MS	N.D.	5	
五溴二苯醚	毫克/千克	IEC 62321/2nd CDV (111/95/CDV), GC-MS	N.D.	5	
六溴二苯醚	毫克/千克	IEC 62321/2nd CDV (111/95/CDV), GC-MS	N.D.	5	
七溴二苯醚	毫克/千克	IEC 62321/2nd CDV (111/95/CDV), GC-MS	N.D.	5	
八溴二苯醚	毫克/千克	IEC 62321/2nd CDV (111/95/CDV), GC-MS	N.D.	5	
九溴二苯醚	毫克/千克	IEC 62321/2nd CDV (111/95/CDV), GC-MS	N.D.	5	
十溴二苯醚 ##	毫克/千克	IEC 62321/2nd CDV (111/95/CDV), GC-MS	N.D.	5	

This document is issued by the Company under its General Conditions of Service printed overleaf or available on request and accessible at http://www.sgs.com/terms_and_conditions.htm. Attention is drawn to the limitation of liability, indemnification and jurisdiction issues defined therein. Any holder of this document is advised that information contained hereon reflects the Company's findings at the time of its intervention only and within the limits of Client's instructions, if any. The Company's sole responsibility is to its Client and this document does not exonerate parties to a transaction from exercising all their rights and obligations under the transaction documents. Any unauthorized alteration, forgery or falsification of the content or appearance of this document is unlawful and offenders may be prosecuted to the fullest extent of the law. Unless otherwise stated the results shown in this test report refer only to the sample(s) tested. This document cannot be reproduced except in full, without prior approval of the Company.

注释:

1. 毫克/千克 = ppm
2. N.D. = 未检出 (< MDL)
3. MDL = 方法检测限
4. ## =根据欧洲法庭2008年4月1日的决议, 2005/717/EC中关于聚合物样品中十溴二苯醚的豁免被否决。自2008年7月1日起, 十溴二苯醚将被包含于多溴二苯醚的总和计算之中。
5. ◇= 点测试:
 - Negative = 未检测到六价铬, Positive = 检测到;
 - (如果点测试结果为Negative或不能确认, 测试样品需进一步由沸水萃取法进行测试。)
 - 沸水萃取法:
 - Negative = 未检测到六价铬
 - Positive = 检测到六价铬; 每50cm²面积的被测试样品的沸水萃取液中六价铬的浓度等于或大于0.02mg/kg。
6. # = Positive = 阳性
Negative = 阴性
7. "-" = 未规定
8. 多溴二苯醚 = 多溴联苯醚
9. 本测试报告内容是参照报告编号为CANEC0900090807的中文译本, 中英文版本如有歧异, 概以英文版为准。

This document is issued by the Company under its General Conditions of Service printed overleaf or available on request and accessible at http://www.sgs.com/terms_and_conditions.htm. Attention is drawn to the limitation of liability, indemnification and jurisdiction issues defined therein. Any holder of this document is advised that information contained hereon reflects the Company's findings at the time of its intervention only and within the limits of Client's instructions, if any. The Company's sole responsibility is to its Client and this document does not exonerate parties to a transaction from exercising all their rights and obligations under the transaction documents. Any unauthorized alteration, forgery or falsification of the content or appearance of this document is unlawful and offenders may be prosecuted to the fullest extent of the law. Unless otherwise stated the results shown in this test report refer only to the sample(s) tested. This document cannot be reproduced except in full, without prior approval of the Company.

附件

- 1) 分析人员: 陈美波
- 2) 项目负责人: 余奕东

测试流程图

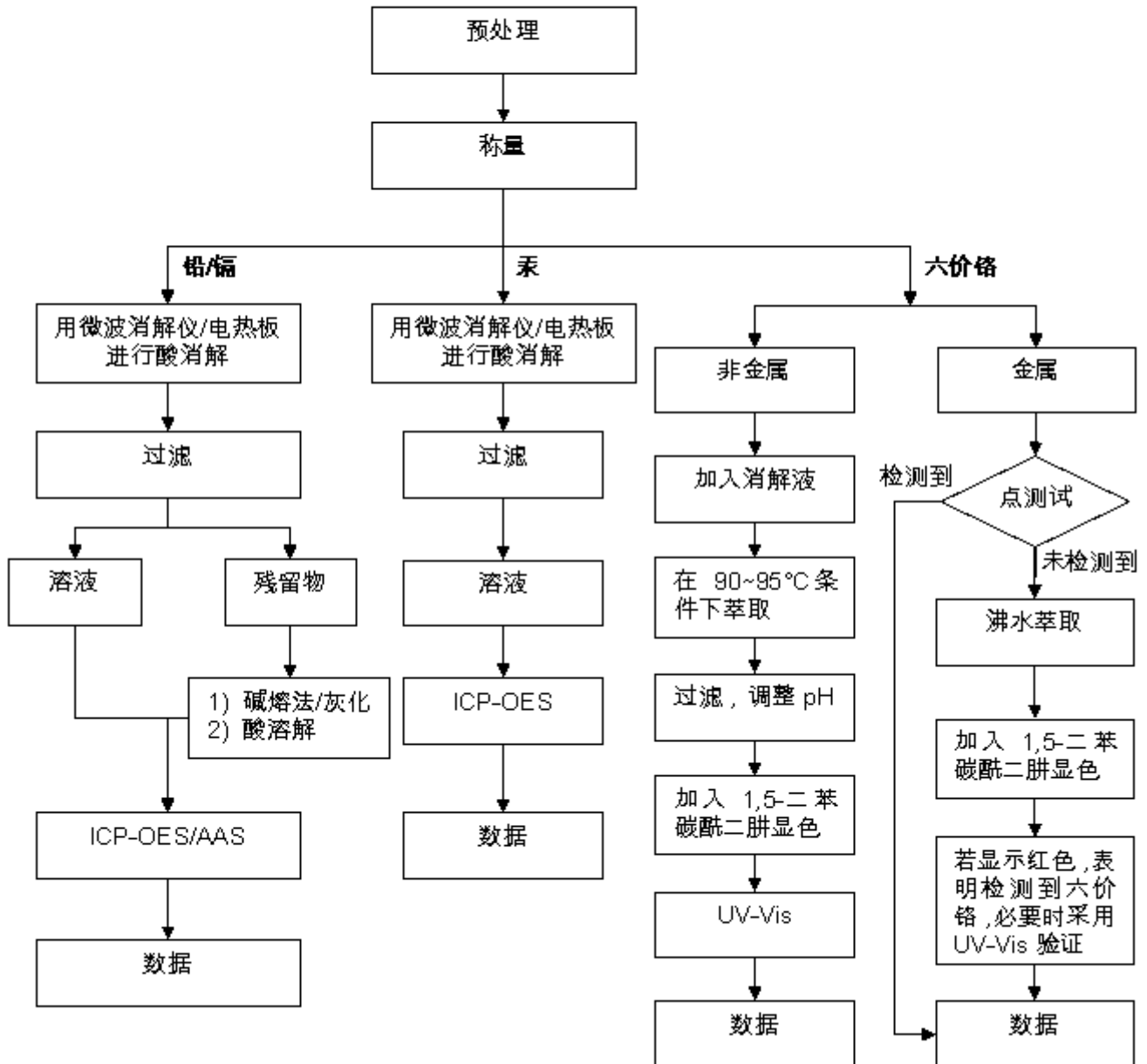

This document is issued by the Company under its General Conditions of Service printed overleaf or available on request and accessible at http://www.sgs.com/terms_and_conditions.htm. Attention is drawn to the limitation of liability, indemnification and jurisdiction issues defined therein. Any holder of this document is advised that information contained hereon reflects the Company's findings at the time of its intervention only and within the limits of Client's instructions, if any. The Company's sole responsibility is to its Client and this document does not exonerate parties to a transaction from exercising all their rights and obligations under the transaction documents. Any unauthorized alteration, forgery or falsification of the content or appearance of this document is unlawful and offenders may be prosecuted to the fullest extent of the law. Unless otherwise stated the results shown in this test report refer only to the sample(s) tested. This document cannot be reproduced except in full, without prior approval of the Company.

测试流程图

- 1) 分析人员: 唐丽娜
- 2) 项目负责人: 赵瑞娜

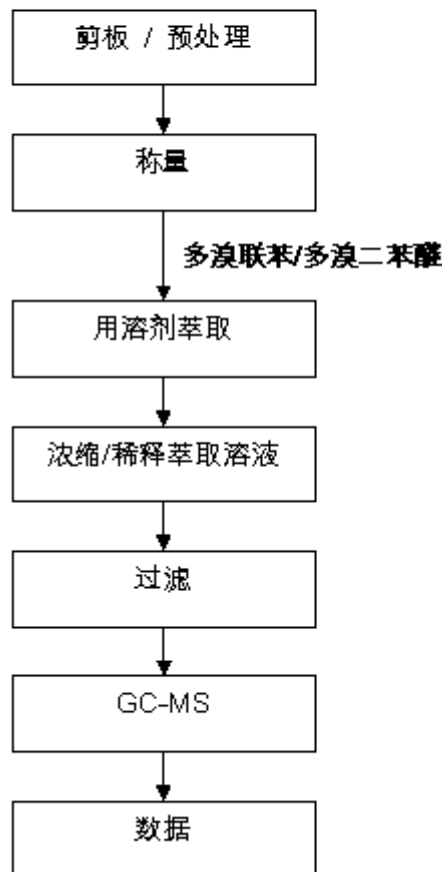

This document is issued by the Company under its General Conditions of Service printed overleaf or available on request and accessible at http://www.sgs.com/terms_and_conditions.htm. Attention is drawn to the limitation of liability, indemnification and jurisdiction issues defined therein. Any holder of this document is advised that information contained hereon reflects the Company's findings at the time of its intervention only and within the limits of Client's instructions, if any. The Company's sole responsibility is to its Client and this document does not exonerate parties to a transaction from exercising all their rights and obligations under the transaction documents. Any unauthorized alteration, forgery or falsification of the content or appearance of this document is unlawful and offenders may be prosecuted to the fullest extent of the law. Unless otherwise stated the results shown in this test report refer only to the sample(s) tested. This document cannot be reproduced except in full, without prior approval of the Company.

测试报告

No. CANEC0900090808

日期: 2009年01月14日 第6页,共6页

样品照片:



此照片仅限于随SGS正本报告使用

*** 报告完 ***

This document is issued by the Company under its General Conditions of Service printed overleaf or available on request and accessible at http://www.sgs.com/terms_and_conditions.htm. Attention is drawn to the limitation of liability, indemnification and jurisdiction issues defined therein. Any holder of this document is advised that information contained hereon reflects the Company's findings at the time of its intervention only and within the limits of Client's instructions, if any. The Company's sole responsibility is to its Client and this document does not exonerate parties to a transaction from exercising all their rights and obligations under the transaction documents. Any unauthorized alteration, forgery or falsification of the content or appearance of this document is unlawful and offenders may be prosecuted to the fullest extent of the law. Unless otherwise stated the results shown in this test report refer only to the sample(s) tested. This document cannot be reproduced except in full, without prior approval of the Company.

无锡源达电工材料有限公司

WUXI YUANDA ELECTRICAL MATERIAL CO., LTD.

中国江苏省江阴市青阳镇南陈村 邮编 214401

Nachen, Qingyang Town, Jiangyin City 214400, Jiangsu, China

1. 适用范围:

Scope

本规格书制定了 50 Ω FEP 绝缘射频电缆 YD178 系列的结构和电气特性。

This specification covers the construction and the electrical properties of YD178 series of 50 Ω FEP Insulation Coaxial Cable.

2. 结构/Construction:

单位/Unit:mm

	项目/Item	详细资料/Details
导体/Conductor	材料/Material	镀银铜线/Silver-coated Copper Wire
	构成(根/mm) Composition(No./mm)	7/0.102
	标称直径/Nom. O. D (mm)	0.306±0.03
绝缘层 /Insulation	材料/Material	聚全氟乙丙烯(自然色) /FEP(Natural)/聚四氟乙烯/PTFE
	标称绝缘厚度/Nom. Thick(mm)	0.275
	标称外径/Nom. O. D (mm)	0.86±0.03
屏蔽层/Shield	材料/Material	镀银铜线/Silver-coated annealed copper wire
	构成/Composition	0.10 单线编织/Single Braid of 0.10
护套/Jacket	材料/Material	聚全氟乙丙烯(*颜色)/FEP(*color)
	标称护套厚度/Nom. Thick(mm)	0.25
	标称外径/Nom. O. D(mm)	1.80±0.08
	颜色/Color	按与客户确认的颜色/According to corresponding have approved by the suppliers and customers

3. 电气特性(20℃时)/Electrical Properties(at 20℃)

项目/Item	单位/Unit	详细资料/Details	
导体电阻/Conductor Resistance	Ω/km	Max. 320	
绝缘电阻/Insulation Resistance	MΩ.km	Min. 500	
耐压强度/Dielectric Strength	V(AC)/min	1000	
静电容/Capacitance	pF/m	105(1kHz)	
特性阻抗/Characteristic Impedance	Ω	50±2.0	
衰减/Attenuation	dB/m	1GHz	1.70
		2GHz	2.42

无锡源达电工材料有限公司

WUXI YUANDA ELECTRICAL MATERIAL CO., LTD.

中国江苏省江阴市青阳镇南陈村 邮编 214401

Nachen, Qingyang Town, Jiangyin City 214400, Jiangsu, China

		3GHz	3.08
		4GHz	3.63
		5GHz	4.15
		6GHz	4.80
驻波比/Standing wave (0-6GHz)	/	≤1.35	

4. 包装 Packing

标准单位包装长度为 400 米/盘, 每盘最多允许 3 个接头, 接头最短长度 20 米, 在搬运过程中不能损坏包装.

Standard unit length of finished cable shall be 400m on reel, frequency of joint max. 3/reel, the mini length is 20m. The finished cable shall be packed not be damaged during transportation

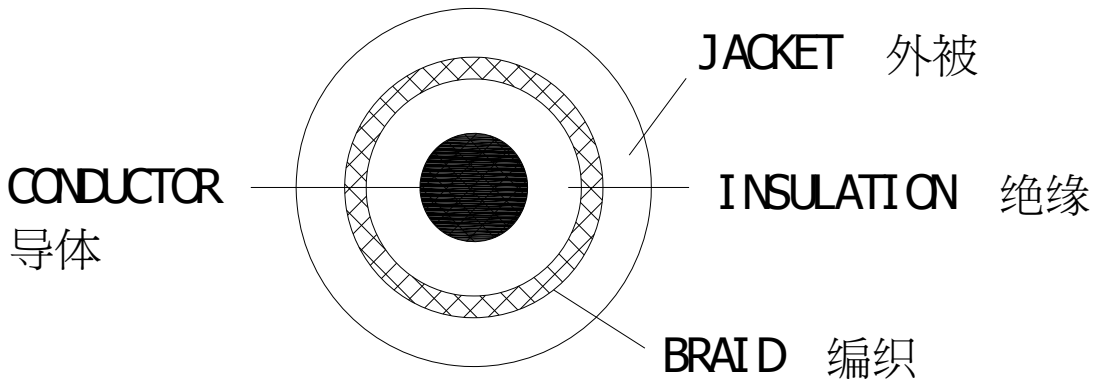

本产品有时不适合车载用途的情况也有,所以使用前请先和本公司业务部门进行商谈.

This product is not suitable for automobile application in some cases. Please contact with our sales department before you use this product.

规格书完
End of specification

Test Report

No. SH9139605/CHEM

Date: Jul. 24, 2009

Page 1 of 11

WUXI YUANDA ELECTRICAL MATERIAL CO., LTD
QINGYANG TOWN NANCHEN VILLAGE, JIANGYIN, JIANGSU

The following sample(s) was/were submitted and identified by/on behalf of the client as:

Sample Name : RF-COAXIAL CABLE
SGS Ref No. : SUZ11962574-3
Part No : RF113 (BROWN)
Sample May Cover : RF081, RF132, RF137, RG178, RG179, RG180, RG187, RG188, RG195, RG196, RG302, RG303, RG316, RG142, RG400

Sample Receiving Date : Jul.17, 2009
Testing Period : Jul.17 – 18, 2009

Test Requested : (1) In accordance with the RoHS Directive 2002/95/EC, and its amendment directives
(2) To determine the Hexabromocyclododecane (HBCDD) content of the submitted samples.
(3) To determine the PFOS (Perfluorooctane Sulfonates) and PFOA (Perfluorooctanoic Acid) content of the submitted samples.
(4) To determine the Halogen- Fluorine, Chlorine, Bromine, Iodine Content in the submitted sample.
(5) To determine the TBBP-A Content in the submitted sample.

Test Method /Test Results: Please refer to next pages

Conclusion : (1) Based on the performed tests on submitted samples, the results comply with the RoHS Directive 2002/95/EC and its subsequent amendments.

Signed for and on behalf of
SGS-CSTC Chemical Laboratory



Sandy Hao
Lab Manager

This document is issued by the Company under its General Conditions of Service printed overleaf or available on request and accessible at http://www.sgs.com/terms_and_conditions.htm. Attention is drawn to the limitation of liability, indemnification and jurisdiction issues defined therein. Any holder of this document is advised that information contained hereon reflects findings at the time of its intervention only and within the limits of Client's instructions, if any. The Company's sole responsibility is to its Client and this document does not generate parties to a transaction from exercising all their rights and obligations under the transaction documents. Any unauthorized alteration, forgery or falsification of the content or appearance of this document is unlawful and offenders may be prosecuted to the fullest extent of the law.
Unless otherwise stated the results shown in this test report refer only to the sample(s) tested. This document cannot be reproduced except in full, without prior approval of the Company.

Test Report

No. SH9139605/CHEM

Date: Jul. 24, 2009

Page 2 of 11

- Test Method : (1) With reference to IEC 62321 :2008
 (1-1) Determination of Cadmium by ICP.
 (1-2) Determination of Lead by ICP.
 (1-3) Determination of Mercury by ICP.
 (1-4) Determination of Hexavalent Chromium by Spot test / Colorimetric Method.
 (1-5) Determination of PBBs and PBDEs by GC/MS.
 (2) With reference to EPA 3550C: 2007.
 Analysis was performed by Gas chromatograph / Mass Spectrometer (GC-MS).
 (3) With reference to EPA 3550C: 2007.
 Analysis was performed by High Performance Liquid Chromatograph-Mass Spectrometer (HPLC-MS).
 (4) With reference to EN 14582: 2007.
 (4-1) Determination of Fluorine by Ion Chromatograph (IC) method.
 (4-2) Determination of Chlorine by Ion Chromatograph (IC) method.
 (4-3) Determination of Bromine by Ion Chromatograph (IC) method.
 (4-4) Determination of Iodine by Ion Chromatograph (IC) method.
 (5) With reference to EPA 3550C: 2007. Analysis was performed by Gas Chromatograph / Mass Spectrometer (GC/MS).

Test results by chemical method (Unit: mg/kg)

(1) Cadmium, Lead, Mercury, Hexavalent Chromium, PBBs(Polybrominated biphenyls) and PBDEs(PBDEs) (Polybrominated biphenyl ethers) Content

Test Item(s):	Method (refer to)	1*	2*	3*	MDL	RoHS Limit
Cadmium(Cd)	(1-1)	ND	ND	ND	2	100
Lead (Pb)	(1-2)	ND	ND	ND	2	1000
Mercury (Hg)	(1-3)	ND	ND	ND	2	1000
Hexavalent Chromium (CrVI) by alkaline extraction	(1-4)	ND	---	ND	2	1000
Hexavalent Chromium (CrVI) by spot test / boiling-water extraction	(1-4)	---	Negative	---	#	-
Sum of PBBs	(1-5)	ND	---	ND	-	1000
Monobromobiphenyl		ND	---	ND	5	-
Dibromobiphenyl		ND	---	ND	5	-
Tribromobiphenyl		ND	---	ND	5	-
Tetrabromobiphenyl		ND	---	ND	5	-
Pentabromobiphenyl		ND	---	ND	5	-
Hexabromobiphenyl		ND	---	ND	5	-
Heptabromobiphenyl		ND	---	ND	5	-
Octabromobiphenyl		ND	---	ND	5	-
Nonabromobiphenyl		ND	---	ND	5	-
Decabromobiphenyl		ND	---	ND	5	-
Sum of PBDEs		ND	---	ND	-	1000
Monobromodiphenyl ether		ND	---	ND	5	-
Dibromodiphenyl ether		ND	---	ND	5	-
Tribromodiphenyl ether		ND	---	ND	5	-
Tetrabromodiphenyl ether		ND	---	ND	5	-

This document is issued by the Company under its General Conditions of Service printed overleaf or available on request and accessible at http://www.sgs.com/terms_and_conditions.htm. Attention is drawn to the limitation of liability, indemnification and jurisdiction issues defined therein. Any holder of this document is advised that information contained hereon reflects findings at the time of its intervention only and within the limits of Client's Instructions, if any. The Company's sole responsibility is to its Client and this document does not constitute a transaction from exercising all their rights and obligations under the transaction documents. Any unauthorized alteration, forgery or falsification of the content or appearance of this document is unlawful and offenders may be prosecuted to the fullest extent of the law. Unless otherwise stated the results shown in this test report refer only to the sample(s) tested. This document cannot be reproduced except in full, without prior approval of the Company.

Test Report

No. SH9139605/CHEM

Date: Jul. 24, 2009

Page 3 of 11

Pentabromodiphenyl ether		ND	---	ND	5	-
Hexabromodiphenyl ether		ND	---	ND	5	-
Heptabromodiphenyl ether		ND	---	ND	5	-
Octabromodiphenyl ether		ND	---	ND	5	-
Nonabromodiphenyl ether		ND	---	ND	5	-
Decabromodiphenyl ether ##		ND	---	ND	5	-

Test Item(s):	Method (refer to)	4	MDL	RoHS Limit
Cadmium(Cd)	(1-1)	ND	2	100
Lead (Pb)	(1-2)	ND	2	1000
Mercury (Hg)	(1-3)	ND	2	1000
Hexavalent Chromium (CrVI) by spot test / boiling-water extraction	(1-4)	Negative	#	-

(2) Hexabromocyclododecane (HBCDD) content

Test Item:	Method (refer to)	1*	3*	MDL
Hexabromocyclododecane (HBCDD)	(2)	ND	ND	5

(3) PFOS (Perfluorooctane Sulfonates) and PFOA (Perfluorooctanoic Acid) content

Test Items	Test method (refer to)	1*	3*	MDL
Perfluorooctane Sulfonates (PFOS) PFOS – Acid PFOS – Metal Salt PFOS – Amide	(3)	ND	ND	10
Perfluorooctyl Acid (PFOA)		-	ND	10

Note : PFOS Reference Information: Directive 2006/122/EC

- (i) May not be placed on the market or used as a substance or constituent of preparations in a concentration equal to or higher than 0.005 % by mass.
- (ii) May not be placed on the market in semi-finished products or articles, or parts thereof, if the concentration of PFOS is equal to or higher than 0.1 % by mass calculated with reference to the mass of structurally or microstructurally distinct parts that contain PFOS or, for textiles or other coated materials, if the amount of PFOS is equal to or higher than 1µg /m² of the coated material.

(4) Halogen Content

Test Item(s):	Method (refer to)	1*	3*	MDL
Fluorine(F)	(4-1)	>10%	>10%	50
Chlorine(Cl)	(4-2)	ND	ND	50
Bromine(Br)	(4-3)	ND	ND	50
Iodine(I)	(4-4)	ND	ND	50

This document is issued by the Company under its General Conditions of Service printed overleaf or available on request and accessible at http://www.sgs.com/terms_and_conditions.htm. Attention is drawn to the limitation of liability, indemnification and jurisdiction issues defined therein. Any holder of this document is advised that information contained hereon reflects the findings at the time of its intervention only and within the limits of Client's Instructions, if any. The Company's sole responsibility is to its Client and this document does not constitute a transaction from exercising all their rights and obligations under the transaction documents. Any unauthorized alteration, forgery or falsification of the content or appearance of this document is unlawful and offenders may be prosecuted to the fullest extent of the law. Unless otherwise stated the results shown in this test report refer only to the sample(s) tested. This document cannot be reproduced except in full, without prior approval of the Company.

(5) TBBP-A Content

Test Item(s):	Method (refer to)	1*	3*	MDL
TBBP-A	(5)	ND	ND	10

Test Part Description:

1. Brown electrical wire wire part
2. Silvery metal wire part
3. Transparent solid tube part
4. Silvery metal wire part

Note:

- (1) mg/kg = ppm
- (2) ND = Not Detected
- (3) MDL = Method Detection Limit
- (4) # = Spot-test:
 Negative = Absence of CrVI coating, Positive = Presence of CrVI coating;
 (The tested sample should be further verified by boiling-water-extraction method if the spot test result is Negative or cannot be confirmed.)
 Boiling-water-extraction:
 Negative = Absence of CrVI coating
 Positive = Presence of CrVI coating; the detected concentration in boiling-water-extraction solution is equal or greater than 0.02 mg/kg with 50 cm² sample surface area.
 For corrosion protection coatings on metals: Information on storage conditions and production date of the tested sample is unavailable and thus results of Cr(VI) represent status of the sample at the time of testing.
- (5) ##=The exemption of DecaBDE in polymeric application according 2005/717/EC was overruled by the European Court of Justice by its decision of 01.04.2008. Subsequently DecaBDE is included in the sum of PBDE after 01.07.2008.
- (6) "-" = Not Regulated
- (7) "---" = Not Conducted
- (8) The maximum permissible limit is quoted from the document 2005/618/EC amending RoHS directive 2002/95/EC
- (9) *The test results 1 are taken from report SH9124454-1/CHEM-1, Date: 2009/07/07
 *The test results 2 are taken from report SH9124450-1/CHEM-1, Date: 2009/07/07
 *The test results 3 are taken from report SH9124450-1/CHEM-2, Date: 2009/07/07

This document is issued by the Company under its General Conditions of Service printed overleaf or available on request and accessible at http://www.sgs.com/terms_and_conditions.htm. Attention is drawn to the limitation of liability, indemnification and jurisdiction issues defined therein. Any holder of this document is advised that information contained hereon reflects the findings at the time of its intervention only and within the limits of Client's instructions, if any. The Company's sole responsibility is to its Client and this document does not constitute an offer of insurance or any other financial product. The Company and its representatives do not warrant the accuracy of the information and the appearance of this document is unlawful and offenders may be prosecuted to the fullest extent of the law. Unless otherwise stated the results shown in this test report refer only to the sample(s) tested. This document cannot be reproduced except in full, without prior approval of the Company.



ATTACHMENTS

- 1) Name of the person who made measurement: Jeff Zhang/Chaven Lian/Frank Fang/Elim Lin
- 2) Name of the person in charge of measurement: Terry Wang/Phoebe Shen
- 3) These samples were dissolved totally by pre-conditioning method according to below flow chart. (Cr⁶⁺ and PBBs/PBDEs test method excluded)

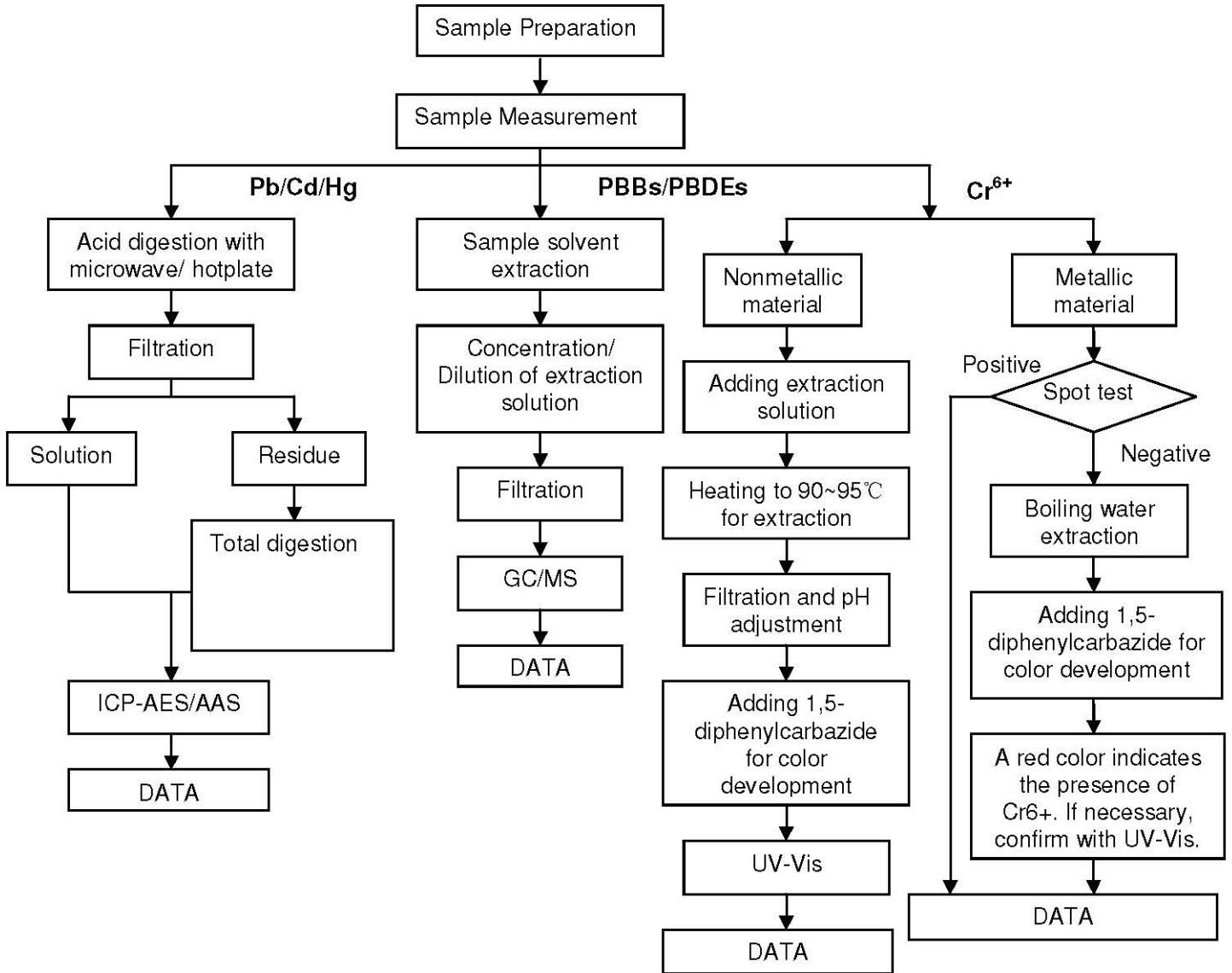

This document is issued by the Company under its General Conditions of Service printed overleaf or available on request and accessible at http://www.sgs.com/terms_and_conditions.htm. Attention is drawn to the limitation of liability, indemnification and jurisdiction issues defined therein. Any holder of this document is advised that information contained hereon reflects the findings at the time of its intervention only and within the limits of Client's Instructions, if any. The Company's sole responsibility is to its Client and this document does not exonerate parties to a transaction from exercising all their rights and obligations under the transaction documents. Any unauthorized alteration, forgery or falsification of the content or appearance of this document is unlawful and offenders may be prosecuted to the fullest extent of the law. Unless otherwise stated the results shown in this test report refer only to the sample(s) tested. This document cannot be reproduced except in full, without prior approval of the Company.



HBCDD Measurement Flowchart for sample

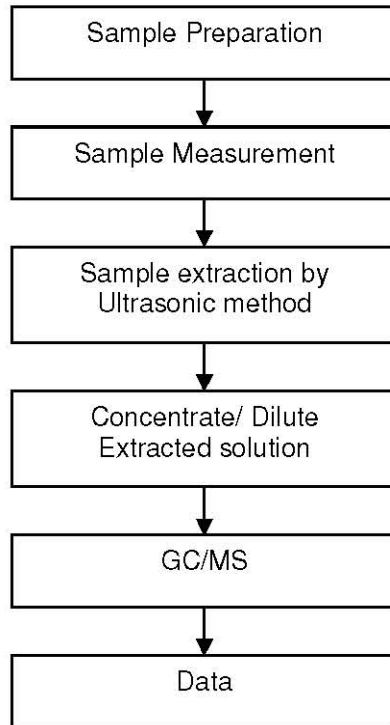

Tested by : Elim Lin
Checked by : Phoebe Shen

This document is issued by the Company under its General Conditions of Service printed overleaf or available on request and accessible at http://www.sgs.com/terms_and_conditions.htm. Attention is drawn to the limitation of liability, indemnification and jurisdiction issues defined therein. Any holder of this document is advised that information contained hereon reflects the findings at the time of its intervention only and within the limits of Client's Instructions, if any. The Company's sole responsibility is to its Client and this document does not constitute parties to a transaction from exercising all their rights and obligations under the transaction documents. Any unauthorized alteration, forgery or falsification of the content or appearance of this document is unlawful and offenders may be prosecuted to the fullest extent of the law. Unless otherwise stated the results shown in this test report refer only to the sample(s) tested. This document cannot be reproduced except in full, without prior approval of the Company.

PFOS/PFOA Measurement Flowchart for sample

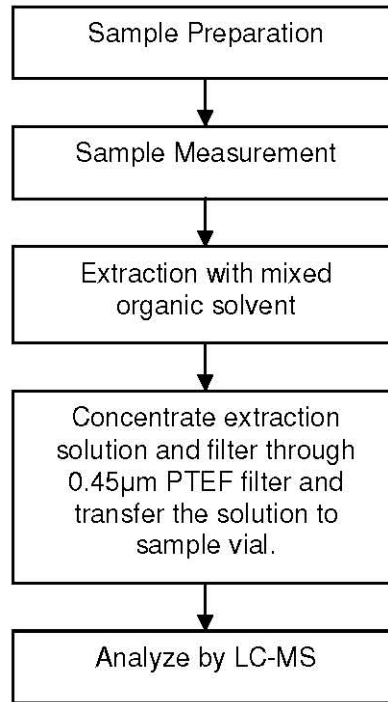

Tested by : Judy Li
 Checked by : Jenny Liu

This document is issued by the Company under its General Conditions of Service printed overleaf or available on request and accessible at http://www.sgs.com/terms_and_conditions.htm. Attention is drawn to the limitation of liability, indemnification and jurisdiction issues defined therein. Any holder of this document is advised that information contained hereon reflects the findings at the time of its intervention only and within the limits of Client's Instructions, if any. The Company's sole responsibility is to its Client and this document does not constitute a transaction from exercising all their rights and obligations under the transaction documents. Any unauthorized alteration, forgery or falsification of the content or appearance of this document is unlawful and offenders may be prosecuted to the fullest extent of the law. Unless otherwise stated the results shown in this test report refer only to the sample(s) tested. This document cannot be reproduced except in full, without prior approval of the Company.



Halogen Measurement Flowchart for sample

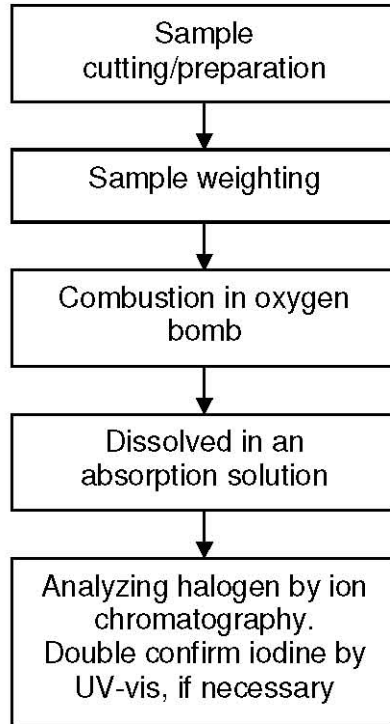

Tested by : Daisy Gong
Checked by : Alex Jiang

This document is issued by the Company under its General Conditions of Service printed overleaf or available on request and accessible at http://www.sgs.com/terms_and_conditions.htm. Attention is drawn to the limitation of liability, indemnification and jurisdiction issues defined therein. Any holder of this document is advised that information contained hereon reflects the findings at the time of its intervention only and within the limits of Client's Instructions, if any. The Company's sole responsibility is to its Client and this document does not exonerate parties to a transaction from exercising all their rights and obligations under the transaction documents. Any unauthorized alteration, forgery or falsification of the content or appearance of this document is unlawful and offenders may be prosecuted to the fullest extent of the law. Unless otherwise stated the results shown in this test report refer only to the sample(s) tested. This document cannot be reproduced except in full, without prior approval of the Company.



TBBP-A Measurement Flowchart for sample

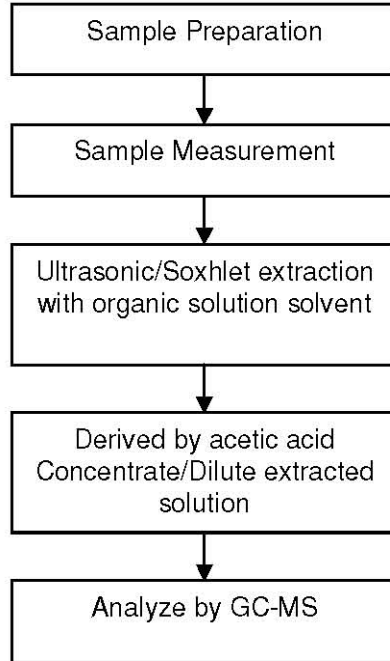

Tested by : Kery Shao
Checked by : Jenny Liu

This document is issued by the Company under its General Conditions of Service printed overleaf or available on request and accessible at http://www.sgs.com/terms_and_conditions.htm. Attention is drawn to the limitation of liability, indemnification and jurisdiction issues defined therein. Any holder of this document is advised that information contained hereon reflects the findings at the time of its intervention only and within the limits of Client's Instructions, if any. The Company's sole responsibility is to its Client and this document does not exonerate parties to a transaction from exercising all their rights and obligations under the transaction documents. Any unauthorized alteration, forgery or falsification of the content or appearance of this document is unlawful and offenders may be prosecuted to the fullest extent of the law. Unless otherwise stated the results shown in this test report refer only to the sample(s) tested. This document cannot be reproduced except in full, without prior approval of the Company.

Sample photo:

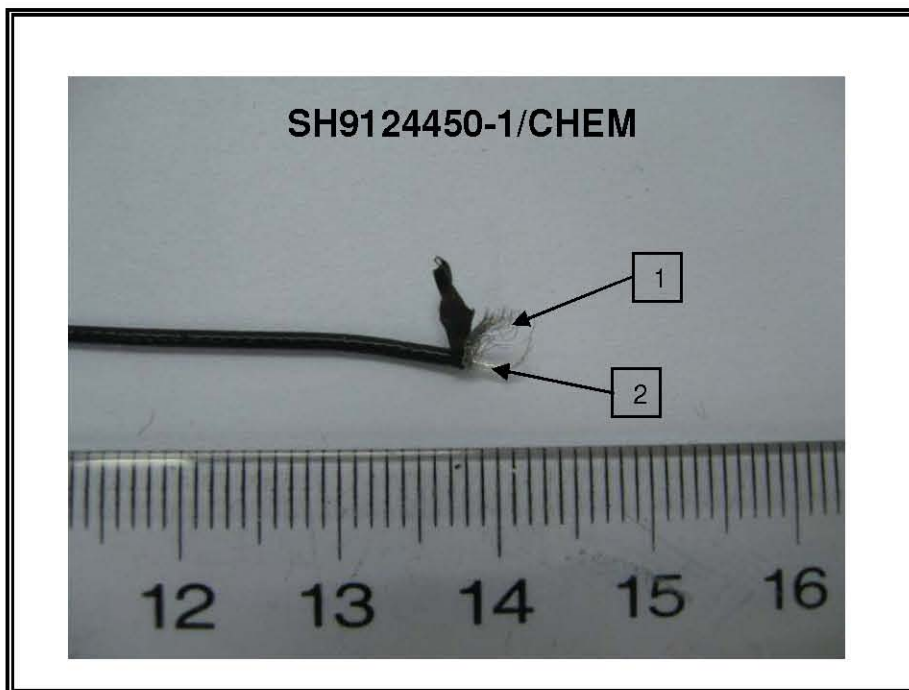
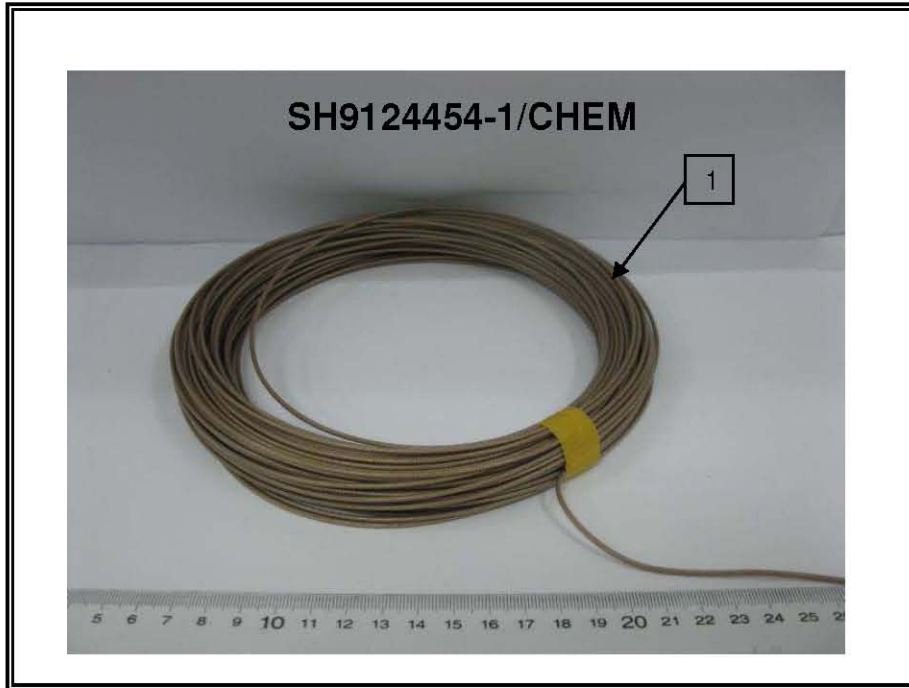

This document is issued by the Company under its General Conditions of Service printed overleaf or available on request and accessible at http://www.sgs.com/terms_and_conditions.htm. Attention is drawn to the limitation of liability, indemnification and jurisdiction issues defined therein. Any holder of this document is advised that information contained hereon reflects the findings at the time of its intervention only and within the limits of Client's instructions, if any. The Company's sole responsibility is to its Client and this document does not exonerate parties to a transaction from exercising all their rights and obligations under the transaction documents. Any unauthorized alteration, forgery or falsification of the content or appearance of this document is unlawful and offenders may be prosecuted to the fullest extent of the law.

Unless otherwise stated the results shown in this test report refer only to the sample(s) tested. This document cannot be reproduced except in full, without prior approval of the Company.

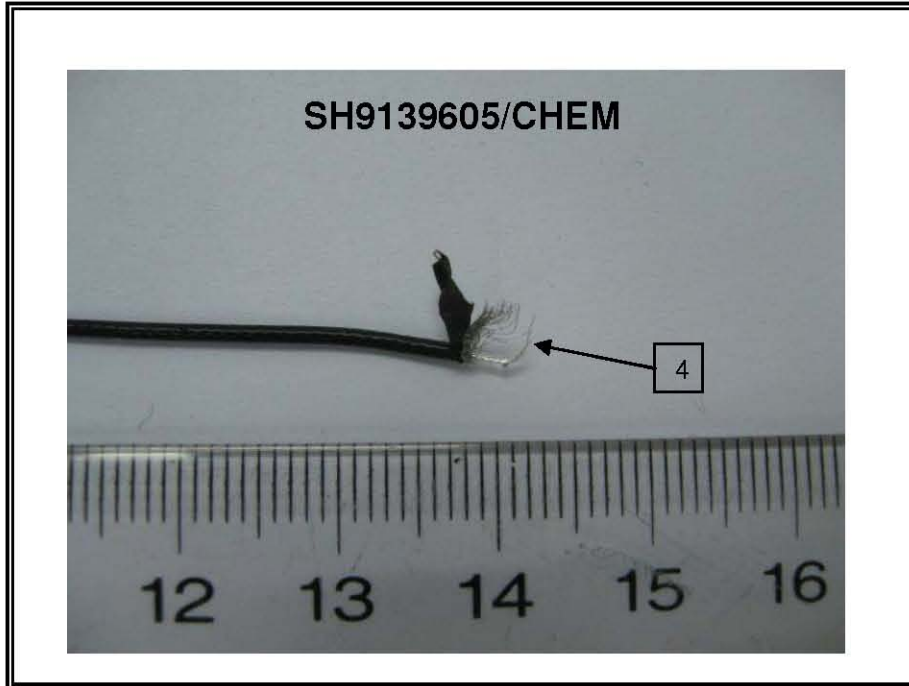

SGS authenticate the photo on original report only

*** End of Report ***

This document is issued by the Company under its General Conditions of Service printed overleaf or available on request and accessible at http://www.sgs.com/terms_and_conditions.htm. Attention is drawn to the limitation of liability, indemnification and jurisdiction issues defined therein. Any holder of this document is advised that information contained hereon reflects the findings at the time of its intervention only and within the limits of Client's instructions, if any. The Company's sole responsibility is to its Client and this document does not exonerate parties to a transaction from exercising all their rights and obligations under the transaction documents. Any unauthorized alteration, forgery or falsification of the content or appearance of this document is unlawful and offenders may be prosecuted to the fullest extent of the law. Unless otherwise stated the results shown in this test report refer only to the sample(s) tested. This document cannot be reproduced except in full, without prior approval of the Company.

测试报告

No. CANEC0900380202

日期: 2009年02月14日 第1页,共3页

南通豪杰金属制品有限公司
中国东莞市长安镇冲头兴业街A座11号

以下测试之样品是由申请者所提供及确认:

碳素弹簧钢丝

SGS工作编号 : 11595921 - SZ
样品接收日期 : 2009年02月10日
测试周期 : 2009年02月10日 - 2009年02月13日
测试要求 : 根据客户要求测试
测试方法 : 请参见下一页
测试结果 : 请参见下一页

通标标准技术服务有限公司
授权签名



Huang Fang, Sunny
Sr. Engineer

This document is issued by the Company under its General Conditions of Service printed overleaf or available on request and accessible at http://www.sgs.com/terms_and_conditions.htm. Attention is drawn to the limitation of liability, indemnification and jurisdiction issues defined therein. Any holder of this document is advised that information contained hereon reflects the Company's findings at the time of its intervention only and within the limits of Client's instructions, if any. The Company's sole responsibility is to its Client and this document does not exonerate parties to a transaction from exercising all their rights and obligations under the transaction documents. Any unauthorized alteration, forgery or falsification of the content or appearance of this document is unlawful and offenders may be prosecuted to the fullest extent of the law. Unless otherwise stated the results shown in this test report refer only to the sample(s) tested. This document cannot be reproduced except in full, without prior approval of the Company.

测试报告

No. CANEC0900380202

日期: 2009年02月14日 第2页,共3页

测试结果:

样品1 ID : CAN09-003802.001
样品1描述 : 银灰色金属线

重金属

测试项目	单位	测试方法 (参考)	测试结果	MDL
镉 (Cd)	毫克/千克	IEC 62321:2008, ICP-OES	N.D.	2
铅 (Pb)	毫克/千克	IEC 62321:2008, ICP-OES	N.D.	2
汞 (Hg)	毫克/千克	IEC 62321:2008, ICP-OES	N.D.	2
沸水萃取法测六价铬 (CrVI)	-	IEC 62321:2008, UV-Vis	Negative	◇

注释:

1. 毫克/千克 = ppm
2. N.D.= 未检出 (< MDL)
3. MDL = 方法检测限
4. ◇ = 点测试:
 - Negative = 未检测到六价铬, Positive = 检测到;
 - (如果点测试结果为Negative或不能确认, 测试样品需进一步由沸水萃取法进行测试。)
- 沸水萃取法:
 - Negative = 未检测到六价铬
 - Positive = 检测到六价铬; 每50cm²表面积的被测试样品的沸水萃取液中六价铬的浓度等于或大于0.02mg/kg。
 - 由于未获知样品的存储条件和生产日期, 样品的六价铬测试结果仅能代表测试时样品含六价铬的状态。
5. "-" = 未规定
6. 本测试报告内容是参照报告编号为CANEC0900380201的中文译本, 中英文版本如有歧异, 概以英文版为准。

This document is issued by the Company under its General Conditions of Service printed overleaf or available on request and accessible at http://www.sgs.com/terms_and_conditions.htm. Attention is drawn to the limitation of liability, indemnification and jurisdiction issues defined therein. Any holder of this document is advised that information contained hereon reflects the Company's findings at the time of its intervention only and within the limits of Client's instructions, if any. The Company's sole responsibility is to its Client and this document does not exonerate parties to a transaction from exercising all their rights and obligations under the transaction documents. Any unauthorized alteration, forgery or falsification of the content or appearance of this document is unlawful and offenders may be prosecuted to the fullest extent of the law. Unless otherwise stated the results shown in this test report refer only to the sample(s) tested. This document cannot be reproduced except in full, without prior approval of the Company.

测试报告

No. CANEC0900380202

日期: 2009年02月14日 第3页,共3页

样品照片:

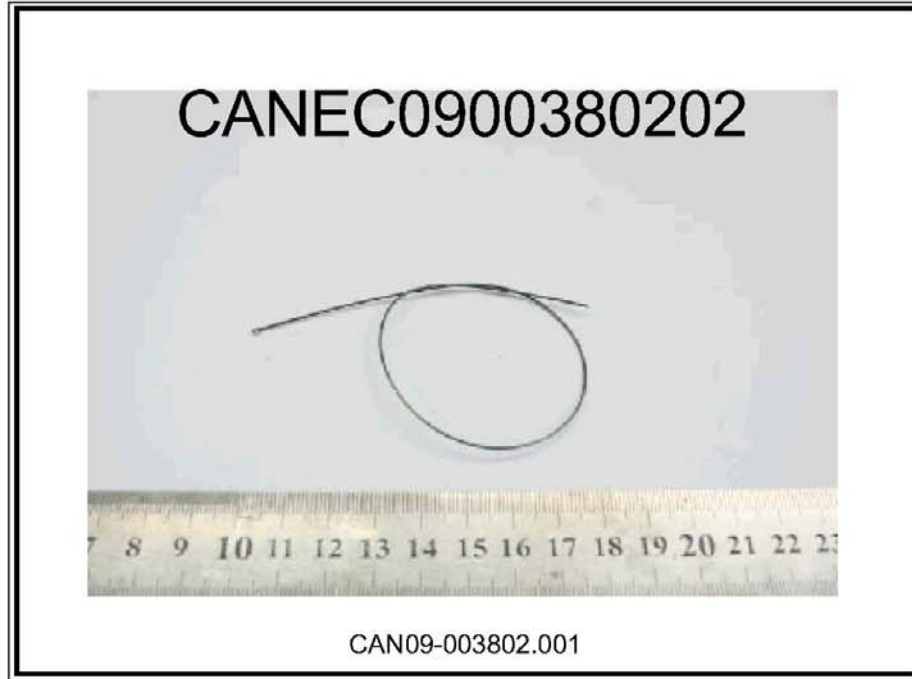

此照片仅限于随SGS正本报告使用

*** 报告完 ***

This document is issued by the Company under its General Conditions of Service printed overleaf or available on request and accessible at http://www.sgs.com/terms_and_conditions.htm. Attention is drawn to the limitation of liability, indemnification and jurisdiction issues defined therein. Any holder of this document is advised that information contained hereon reflects the Company's findings at the time of its intervention only and within the limits of Client's instructions, if any. The Company's sole responsibility is to its Client and this document does not exonerate parties to a transaction from exercising all their rights and obligations under the transaction documents. Any unauthorized alteration, forgery or falsification of the content or appearance of this document is unlawful and offenders may be prosecuted to the fullest extent of the law. Unless otherwise stated the results shown in this test report refer only to the sample(s) tested. This document cannot be reproduced except in full, without prior approval of the Company.

X-ON Electronics

Largest Supplier of Electrical and Electronic Components

Click to view similar products for [Antennas](#) category:

Click to view products by [Advantech](#) manufacturer:

Other Similar products are found below :

[GAN30084EU](#) [930-033-R](#) [GW17.07.0250E](#) [1513563-1](#) [EXE902SM](#) [APAMPG-117](#) [MAF94383](#) [W3908B0100](#) [W6102B0100](#) [YE572113-30RSMM](#) [108-00014-50](#) [66089-2406](#) [SPDA17RP918](#) [A09-F8NF-M](#) [A09-F5NF-M](#) [RGFRA1903041A1T](#) [W3593B0100](#) [W3921B0100](#) [SIMNA-868](#) [SIMNA-915](#) [SIMNA-433](#) [W1044](#) [W1049B090](#) [A75-001](#) [WTL2449CQ1-FRSMM](#) [CPL9C](#) [EXB148BN](#) [0600-00060](#) [TRA9020S3PBN-001](#) [Y4503](#) [GD5W-28P-NF](#) [MA9-7N](#) [GD53-25](#) [GD5W-21P-NF](#) [C37](#) [MAF94051](#) [MA9-5N](#) [EXD420PL](#) [B1322NR](#) [QWFTB120](#) [MAF94271](#) [MAF94300](#) [GPSMB301](#) [FG4403](#) [AO-AGSM-OM54](#) [5200232](#) [MIKROE-2349](#) [WCM.01.0111](#) [MIKROE-2393](#) [MIKROE-2352](#)