

# SPC-221



product  
design award

2013

## 21.5" Full HD LED LCD Stationary Multi-Touch Panel Computer

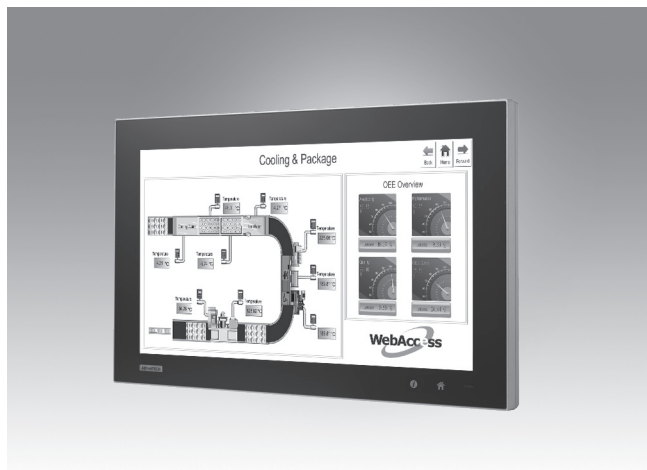

### Features

- 21.5" Full HD TFT LED LCD display
- Intel® Skylake Core™ i3-6100U 2.3 GHz processor (Dual-Core)
- 16:9 wide screen with PCT multi-touch
- Built-in function and home key buttons for intuitive UI
- Anti-scratch touch surface: 7H hardness
- All-round IP66 protection with waterproof M12 connector
- Supports Mini-PCIe expansion slot
- Front LED indicator to show operating status
- Fanless cooling system
- Winner of the 2013 iF product design award



### Introduction

With a brand-new ID design, the SPC-221 series have high resolution 21.5" displays and PCT multi-touch screens in 16:9 wide format. By embedding an Intel® Skylake Core™ i3-6100U 2.3 GHz processor (Dual-Core), the SPC-221 can support advanced graphical performance in complex applications. It has built-in function and home key buttons for greater usability and also supports a Mini-PCIe slot for communication function expansion. It also has an all-round IP66 waterproof casing design with M12 connectors. With this vertical I/O connector, cable routing is simplified, safer, and more reliable for stationary / VESA arm applications.

### Specifications

#### General

- **Certification** BSMI, CCC, CE, FCC Class A, UL
- **Cooling System** Fanless design
- **Dimensions (W x H x D)** 21.5": 558.4 x 349.8 x 65 mm (21.98" x 13.77" x 2.56")
- **Enclosure** Front bezel: Die-cast Aluminium alloy  
Back housing: Die-cast Aluminium alloy
- **Mounting** VESA Arm
- **OS Support** Microsoft® Win7/8/10/WES7P
- **Power Consumption** 35 W Typical
- **Power Input** 24 V<sub>DC</sub>
- **Weight (Net)** 9 kg (19.8 lbs)

#### System Hardware

- **CPU** Intel 6th Core U-series -  
Intel Core i7-6600U, 2.6GHz (optional)  
i5-6300U, 2.4GHz (optional)  
i3-6100U, 2.3GHz  
Celeron-3955U, 2.0GHz (optional)
- **Memory** 8GB SO-DIMM DDR3L SDRAM
- **LAN** 10/100/1000Base-T x 2 (connection:M12 A-coded, 8-pin female)
- **Expansion Slots** Full-sized Mini PCIe slot x 1 (optional)
- **Storage** 2.5" SATA HDD bracket x 1
- **I/O** RS-232 x1 (connection:M12 A-coded, 8-pin male)  
USB 2.0 x1 (connection:M12 A-coded, 8-pin female)  
24 V<sub>DC</sub> power input (connection:M12 A-coded, 5-pin male)

#### LCD Display

- **Display Type** 21.5": Full HD TFT LED
- **Display Size** 21.5"
- **Max. Resolution** 21.5": 1920 x 1080
- **Max. Colors** 16.7 M
- **Luminance cd/m<sup>2</sup>** 300
- **Viewing Angle (H/V°)** 21.5": 178/178
- **Backlight** Life 50,000 hrs

#### Touchscreen

- **Light Transmission** ≥88%
- **Resolution** 4096\*4096 dot
- **Type** Projected capacitive

#### Environment

- **Humidity** 10 ~ 95% RH @ 40°C, non-condensing  
Note: Tested for 48hrs
- **Ingress Protection** All-round IP66 protection
- **Operating Temperature** 0 ~ 55°C (32 ~ 131°F)
- **Storage Temperature** -20 ~ 60°C (-4 ~ 140°F)
- **Vibration Protection** With HDD: 1 Grms (5 ~ 500 Hz)  
(Operating, random vibration)

### Rear View

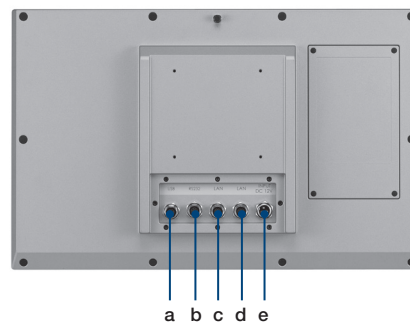

- a. USB 2.0 with M12 connector
- b. COM (RS-232) with M12 connector
- c. LAN 1 with M12 connector
- d. LAN 2 with M12 connector
- e. 24 V<sub>DC</sub> input with M12 connector

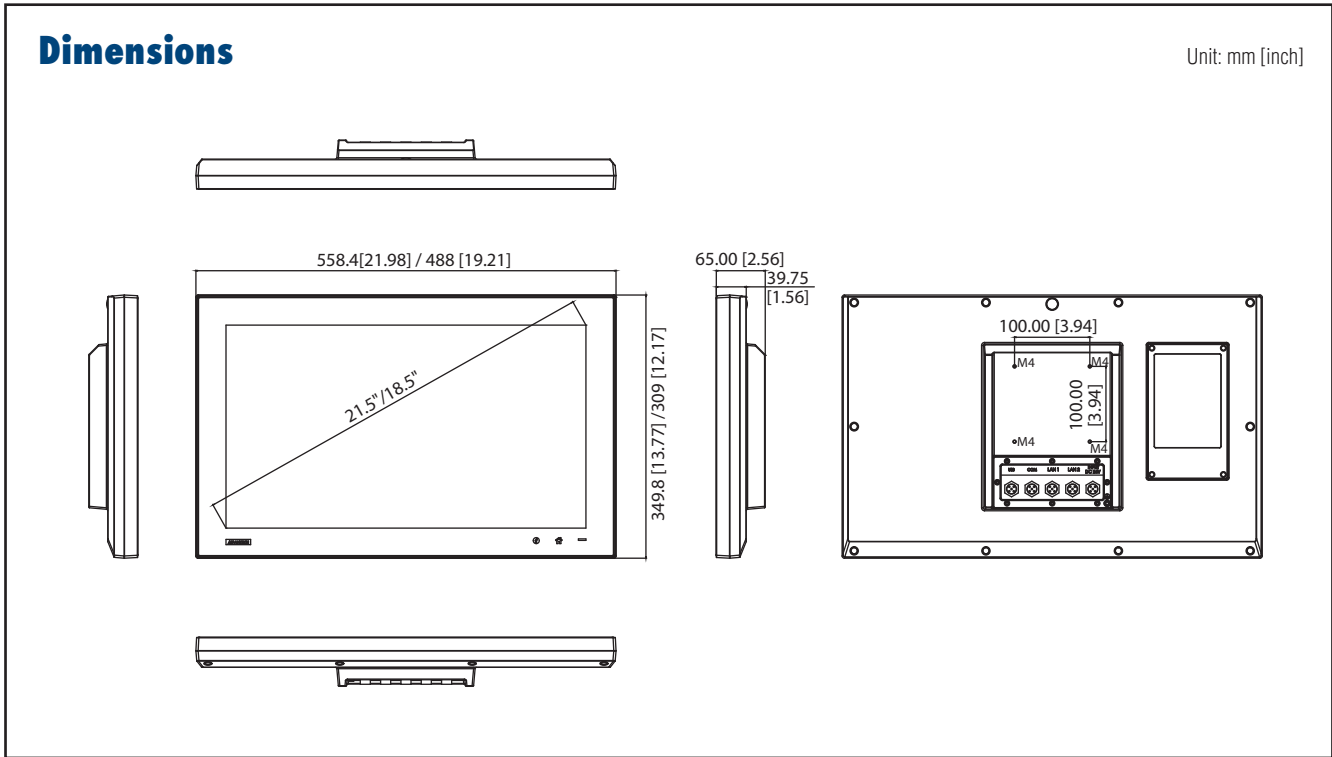

### Ordering Information

- **SPC-221-633AE**      21.5" full-HD Stationary Panel PC / I3-6100U,8GB

### Optional Accessories

- **1702002600**      Power cable US plug 1.8 M
- **1702002605**      Power cable EU plug 1.8 M
- **1702031801**      Power cable UK plug 1.8 M
- **1700000596**      Power cable China/Australia plug 1.8 M
- **EWM-W151H01E**    802.11bgn RTL8188EE 1T1R, Half-size Mini-PCle (also need 9656EWMG00E)
- **9656EWMG00E**      Half-size miniPCle to Full-size miniPCle bracket set
- **1750007668-01**    Waterproof wireless antenna R/P SMA.M2dB L=86.7
- **1750003418**      Wireless antenna AN2400-5901RS R/P SMA.M9dB
- **SPC-1840WP-MCKE**    M12 cable accessory kit for SPC series
- **SPC-1840WP-MOKE**    M12 connector accessory kit for SPC series

### Application Software

<b>WebAccess/SCADA</b>	<p>Advantech WebAccess is a 100% web based SCADA (Supervisory Control And Data Acquisition) software and it acts as an IIoT Platform providing open interfaces for partners to develop IoT applications for different vertical markets. In addition to traditional SCADA functions, WebAccess has an intelligent Dashboard, to provide users with cross-platform, cross-browser data analysis and user interface using HTML5 technology. As well as the built-in widgets, WebAccess also provides Widget Builder to allow customers to build their own.</p>
<b>WebAccess/HMI</b>	<p>WebAccess/HMI is Human Machine Interface (HMI) software based on Microsoft's Windows operating system. It utilizes a PC's ample resources, ie speed, storage, multimedia, peripheral devices, and large screen to produce a complex human-machine interface. WebAccess/HM with its communication and monitoring ability supports more than 350 PLC communication protocols and a wide choice of screen design objects, to satisfy multiple integrations of factory automation and all-round human-machine interface operation and monitoring requirements.</p>

## X-ON Electronics

Largest Supplier of Electrical and Electronic Components

*Click to view similar products for [Panel PCs category](#):*

*Click to view products by [Advantech manufacturer](#):*

Other Similar products are found below :

[GOT-5100T-832](#) [GOT-3126T-832](#) [BYARM-W071-PC](#) [STC-15WR-E3950,4G,64GB M.2](#) [STC-15WP-E3950,4G,64GB M.2](#) [POC-W152-C11D-ACE](#) [PWS-770-VMOUNT00E](#) [PWS-870-CHDC00E](#) [PWS-870-UCOVER00E](#) [TPC-31T-E3AE](#) [TREK-572-LWB7B0E](#) [ESRP-HMI-TPC1551](#) [ESRP-HMI-TPC1251](#) [ESRP-HMI-TPCB200](#) [BYARM-181-PC](#) [BYTEM-121-PC](#) [IDOOH-210-IR](#) [AFL3-W15A-BT-J1/PC/2G-R13](#) [IOVU-07F-AD-WBC-R10](#) [003002400100](#) [1050387](#) [SPTM20XP](#) [XPTB10X](#) [UTC-W101BF-ABI0E](#) [UTC-W101B-ABI0E](#) [UTC-W101B-AWI0E](#) [UTC-532C-GE](#) [UTC-532A-GE](#) [UTC-520A-PE](#) [UTC-520A-GE](#) [TREK-722R-A1E](#) [TREK-570-00A0E](#) [PWS-870-7S6G4P5F0E](#) [PPC-174T-WL-MTE](#) [110070048](#)