

TPC-71W

7" Touch Panel Computer with ARM Cortex™-A9 Processor

NEW



Features

- NXP® ARM® Cortex™-A9 i.MX6 dual/quad-core processor
- 7" 16:9 WSVGA LCD with multi-touch P-CAP control and true-flat IP66-rated front panel
- Up to 2 GB DDR3L RAM and 8 GB eMMC storage onboard
- 10/100/1000 Mbps LAN with IEEE 802.3at PoE-PD support
- 1 MB FRAM backup memory for unexpected power interruptions
- Serial port with 120Ω termination resistor that supports the CAN 2.0B protocol and offers a programmable bit rate of up to 1 Mb/sec
- Embedded browser and VNC tool for rapid Web App development
- Supports Linux Yocto, Linux Ubuntu and Android
- Optional NFC and mPCIe expansion modules
- Compatible with VESA and panel mounting
- Wide operating temperature range (-20 ~ 60 °C/-4 ~ 140 °F)

Introduction

TPC-71W is a compact touch panel computer equipped with an NXP® i.MX 6 Cortex™-A9 dual/quad-core processor, 7" TFT LCD display, multi-touch glass sensor, 2 GB of DDR3L RAM, and 8 GB of eMMC storage. To ensure stable operation in harsh industrial environments, TPC-71W supports a wide operating temperature range (-20 ~ 60 °C/-4 ~ 140 °F) and VESA mounting and features an IP66-rated front panel that protects against water and dust ingress.

For web-based operations, TPC-71W offers 10/100/1000 Mbps LAN that supports the IEEE 802.3 PoE-PD standard. The inclusion of VNC Tools and browsers enable rapid Web application development and easy configuration. Finally, TPC-71W supports various OS including Linux Yocto, Linux Ubuntu with full QT graphics, and Android to ensure easy deployment for diverse applications.

Specifications

General

- **Certification** CE, BSMI, CCC, UL, FCC Class A
- **Dimensions (W x H x D)** 205 x 146.92 x 46 mm (8.07 x 5.78 x 1.81 in)
- **Cutout Dimensions** 192 x 138.5 mm (7.56 x 5.45 in)
- **OS Support** Linux Yocto 2.1, Linux Ubuntu 16.04 and Android 6
- **Power Input** 24V_{DC} ±20%
- **Power Consumption** 9W (typical)
- **Unit Enclosure** Die-cast aluminum alloy front bezel
PC + ABS rear housing
- **Mount Options** Panel and VESA
- **Weight (Net)** 1.2 kg (2.65 lb)

System Kernel

- **CPU** NXP® ARM® Cortex™-A9 i.MX6 dual/quad-core
1.0 GHz processor
- **Backup Memory** FRAM 1 MB
- **Memory** Dual core: 1 GB DDR3L RAM
Quad core: 2 GB DDR3L RAM
- **Storage** 8 GB eMMC onboard

Communication Interface

- **Serial Port** 1 x DB9 selectable mode for RS-232/485 and CAN 2.0 B
- **LAN** 1 x RJ45 with 10/100/1000 Mbps LAN supporting IEEE 802.3af PoE /802.3at PoE+ PD standard
- **Others** 1 x USB 2.0 Type-B Client
2 x USB 2.0 Type-A Host
1 x Micro SD

LCD Panel

- **Panel Type** WSVGA TFT LCD
- **Panel Size** 7 in (177.8 mm)
- **Max. Resolution** 1024 x 600
- **Max. Colors** 16.7M
- **Luminance** 400 cd/m²
- **Viewing Angle (H/V)** 170/170
- **Backlight Life** 50,000 hrs
- **Treatment** Anti-glare
- **Contrast Ratio** 800:1
- **Front Panel LED Indicator** Yes

Touchscreen

- **Touch Points** 10 Points
- **Light** Transmission above 85%
- **Pencil Hardness** ≥7H
- **Type** Projected capacitive (P-CAP) touch

Environment

- **Operating Temperature** -20 ~ 60 °C (-4 ~ 140 °F)
- **Storage Temperature** -30 ~ 70 °C (-22 ~ 158 °F)
- **Humidity** 10 ~ 90% RH @ 40 °C, non-condensing
- **Ingress Protection** IP66-rated front panel
- **Vibration Protection** 2 Grms random vibration (5 ~ 500 Hz) during operation (compliant with IEC60068-2-64)
- **Shock Protection** 10 G shock under 11 ms operation (compliant with IEC60068-2-27)

Dimensions

Unit: mm

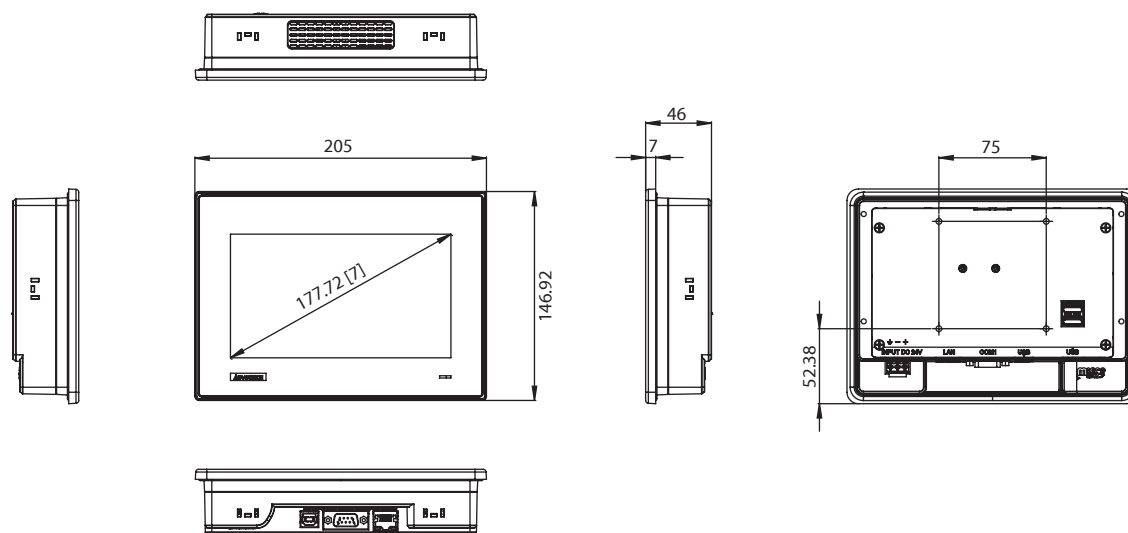

Panel Cutout Dimensions: 192 x 138.5 mm (7.56 x 5.45 in)

Ordering Information

- **TPC-71W-N10PA** 7" Touch Panel Computer, WSVGA, Cortex™-A9 Dual Core CPU, 1GB DDR3L
- **TPC-71W-N21PA** 7" Touch Panel Computer, WSVGA, Cortex™-A9 Quad Core CPU, 2GB DDR3L

Optional Accessories

- **96PSA-A60W24T2** Adaptor A/D 100 ~ 240V 60W 24V C14 cord-end terminal
- **1702002600** Power cable with US plug, 1.8 M
- **1702002605** Power cable with EU plug, 1.8 M
- **1702031801** Power cable with UK plug, 1.8 M
- **1702031836** Power cable with China/Australia plug, 1.8 M

PoE Module Expansion

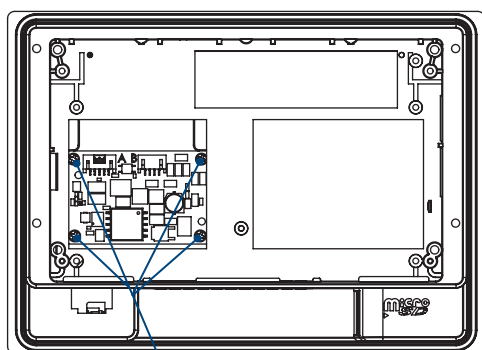

Screw M2.5x4L

External I/O

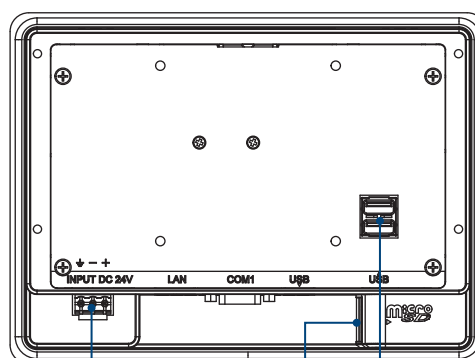

Power Input

Type A USB Host
Micro SD Slot

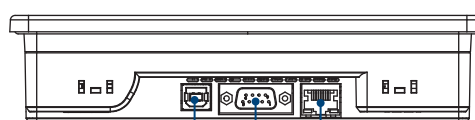

Type B USB Client
Ethernet
RS-232/485/CAN

X-ON Electronics

Largest Supplier of Electrical and Electronic Components

Click to view similar products for [Panel PCs category](#):

Click to view products by [Advantech manufacturer](#):

Other Similar products are found below :

[GOT-5100T-832](#) [GOT-3126T-832](#) [BYARM-W071-PC](#) [STC-15WR-E3950,4G,64GB M.2](#) [STC-15WP-E3950,4G,64GB M.2](#) [POC-W152-C11D-ACE](#) [PWS-770-VMOUNT00E](#) [PWS-870-CHDC00E](#) [PWS-870-UCOVER00E](#) [TREK-572-LWB7B0E](#) [ESRP-HMI-TPC1551](#) [ESRP-HMI-TPC1251](#) [ESRP-HMI-TPCB200](#) [BYARM-181-PC](#) [BYTEM-121-PC](#) [IDOOH-210-IR](#) [AFL3-W15A-BT-J1/PC/2G-R13](#) [IOVU-07F-AD-WBC-R10](#) [003002400100](#) [1050387](#) [SPTM20XP](#) [XPTB10X](#) [UTC-W101BF-ABI0E](#) [UTC-W101B-ABI0E](#) [UTC-W101B-AWI0E](#) [UTC-532C-GE](#) [UTC-532A-GE](#) [UTC-520A-PE](#) [UTC-520A-GE](#) [TREK-722R-A1E](#) [TREK-570-00A0E](#) [PWS-870-7S6G4P5F0E](#) [PPC-174T-WL-MTE](#)
[110070048](#)