

Standard Products  
**ACT 7000SC**  
**64-Bit Superscaler Microprocessor**

www.aeroflex.com/Avionics

October 9, 2009



## FEATURES

- Full militarized QED RM7000 microprocessor
- Dual Issue symmetric superscaler microprocessor with instruction prefetch optimized for system level price/performance
  - 150, 200, 210, 225 MHz operating frequency  
Consult Factory for latest speeds
  - MIPS IV Superset Instruction Set Architecture
- High performance interface (RM52xx compatible)
  - 600 MB per second peak throughput
  - 75 MHz max. freq., multiplexed address/data
  - Supports 1/2 clock multipliers (2, 2.5, 3, 3.5, 4, 4.5, 5, 6, 7, 8, 9)
  - IEEE 1149.1 JTAG (TAP) boundary scan
- Integrated primary and secondary caches - all are 4-way set associative with 32 byte line size
  - 16KB instruction
  - 16KB data: non-blocking and write-back or write-through
  - 256KB on-chip secondary: unified, non-blocking, block writeback
- MIPS IV instruction set
  - Data PREFETCH instruction allows the processor to overlap cache miss latency and instruction execution
  - Floating point combined multiply-add instruction increases performance in signal processing and graphics applications
  - Conditional moves reduce branch frequency
  - Index address modes (register + register)
- Embedded supply de-coupling capacitors and additional PLL filter components
- Integrated memory management unit (ACT52xx compatible)
  - Fully associative joint TLB (shared by I and D translations)
  - 48 dual entries map 96 pages
  - 4 entry DTLB and 4 entry ITLB
  - Variable page size (4KB to 16MB in 4x increments)
- Embedded application enhancements
  - Specialized DSP integer Multiply-Accumulate instruction, (MAD/MADU) and three-operand multiply instruction (MUL/U)
  - Per line cache locking in primaries and secondary
  - Bypass secondary cache option
  - I&D Test/Break-point (Watch) registers for emulation & debug
  - Performance counter for system and software tuning & debug
  - Ten fully prioritized vectored interrupts - 6 external, 2 internal, 2 software
  - Fast Hit-Writeback-Invalidate and Hit-Invalidate cache operations for efficient cache management
- High-performance floating point unit - 600 M FLOPS maximum
  - Single cycle repeat rate for common single-precision operations and some double-precision operations
  - Single cycle repeat rate for single-precision combined multiply- add operations
  - Two cycle repeat rate for double-precision multiply and double-precision combined multiply-add operations
- Fully static CMOS design with dynamic power down logic
  - Standby reduced power mode with WAIT instruction
  - 4 watts typical @ 2.5V Int., 3.3V I/O, 200MHz
- 208-lead CQFP, cavity-up package (F17)
- 208-lead CQFP, inverted footprint (F24), with the same pin rotation as the commercial QED RM5261

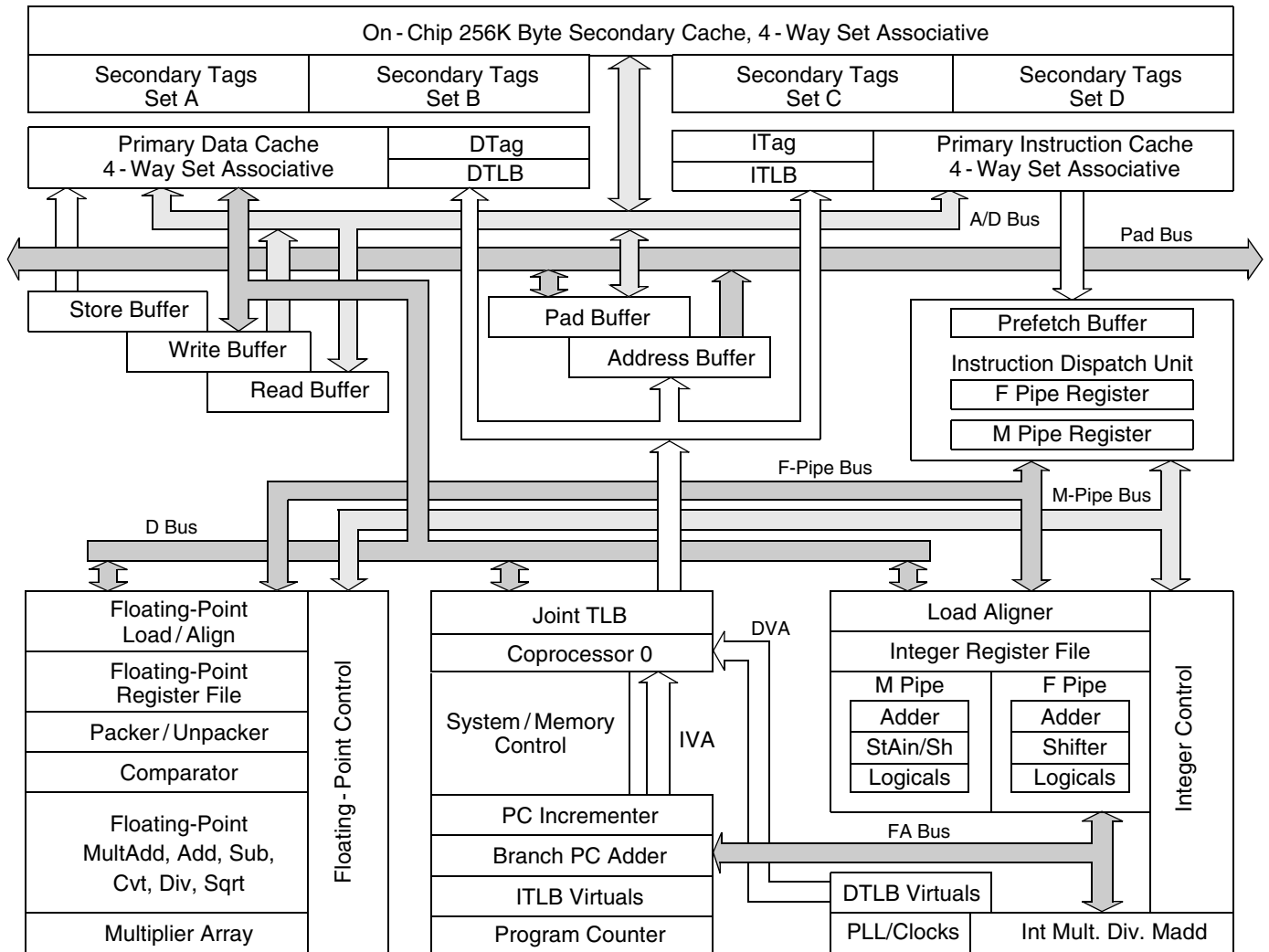

## Block Diagram

## DESCRIPTION

The ACT 7000SC is a highly integrated symmetric superscalar microprocessor capable of issuing two instructions each processor cycle. It has two high performance 64-bit integer units as well as a high throughput, fully pipelined 64-bit floating point unit. To keep its multiple execution units running efficiently, the ACT 7000SC integrates not only 16KB 4-way set associative instruction and data caches but backs them up with an integrated 256KB 4-way set associative secondary as well. For maximum efficiency, the data and secondary caches are writeback and nonblocking. A RM52XX family compatible, operating system friendly memory management unit with a 64/48-entry fully associative TLB and a high-performance 64-bit system interface supporting hardware prioritized and vectored interrupts round out the main features of the processor.

The ACT 7000SC is ideally suited for highend embedded control applications such as internetworking, high performance image manipulation, high speed printing, and 3-D visualization.

## HARDWARE OVERVIEW

The ACT 7000SC offers a high-level of integration targeted at high-performance embedded applications. The key elements of the ACT 7000SC are briefly described below.

## CPU Registers

Like all MIPS ISA processors, the ACT 7000SC CPU has a simple, clean user visible state consisting of 32 general purpose registers, or GPR's, two special purpose registers for integer multiplication and division, and a program counter; there are no condition code bits. Figure 1 shows the user visible state.

## Superscalar Dispatch

The ACT 7000SC has an efficient symmetric superscalar dispatch unit which allows it to issue up to two instructions per cycle. For purposes of instruction issue, the ACT 7000SC defines four classes of instructions: integer, load/store, branches, and floating-point. There are two logical pipelines, the *function*, or F, pipeline and the *memory*, or M, pipeline. Note however that the M pipe can execute integer as well as memory type instructions.

**Table 1 – Instruction Issue Rules**

F Pipe	M Pipe
one of:	one of:
integer, branch, floating-point, integer mul, div	integer, load/store

Figure 2 is a simplification of the pipeline section and illustrates the basics of the instruction issue mechanism.

### General Purpose Registers

63	0
0	
r1	
r2	
•	
•	
•	
•	
r29	
r30	
r31	

### Multiply/Divide Registers

63	0
HI	
63	0
LO	

### Program Counter

63	0
PC	

**Figure 1 – CP0 Registers**

**Table 2 – Dual Issue Instruction Classes**

integer	load/store	floating-point	branch
add, sub, or, xor, shift, etc.	lw, sw, ld, sd, ldc1, sdc1, mov, movc, fmov, etc.	fadd, fsub, fmult, fmadd, fdiv, fcmp, fsqrt, etc.	beq, bne, bCzT, bCzF, j, etc.

The symmetric superscalar capability of the ACT 7000SC, in combination with its low latency integer execution units and high-throughput fully pipelined floating-point execution unit, provides unparalleled price/performance in computational intensive embedded applications.

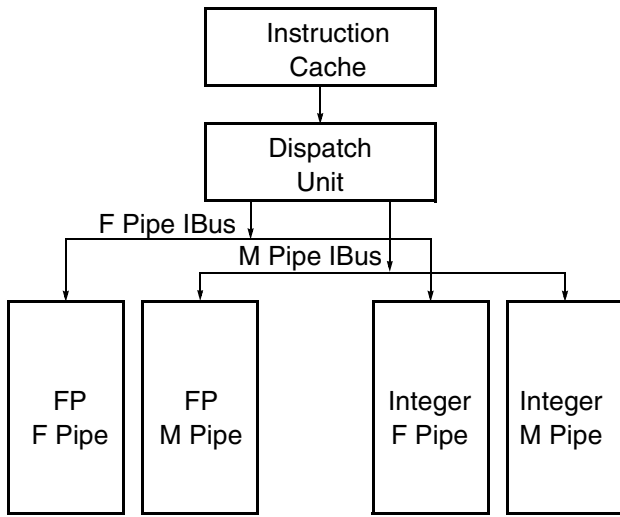

**Figure 2 – Instruction Issue Paradigm**

The figure illustrates that one F pipe instruction and one M pipe instruction can be issued concurrently but that two M pipe or two F pipe instructions cannot be issued. Table 2 specifies more completely the instructions within each class.

**Pipeline**

The logical length of both the F and M pipelines is five stages with state committing in the register write, or W, pipe stage. The physical length of the floating-point execution pipeline is actually seven stages but this is completely transparent to the user.

Figure 3 shows instruction execution within the ACT 7000SC when instructions are issuing simultaneously down both pipelines. As illustrated in the figure, up to ten instructions can be executing simultaneously. This figure presents a somewhat simplistic

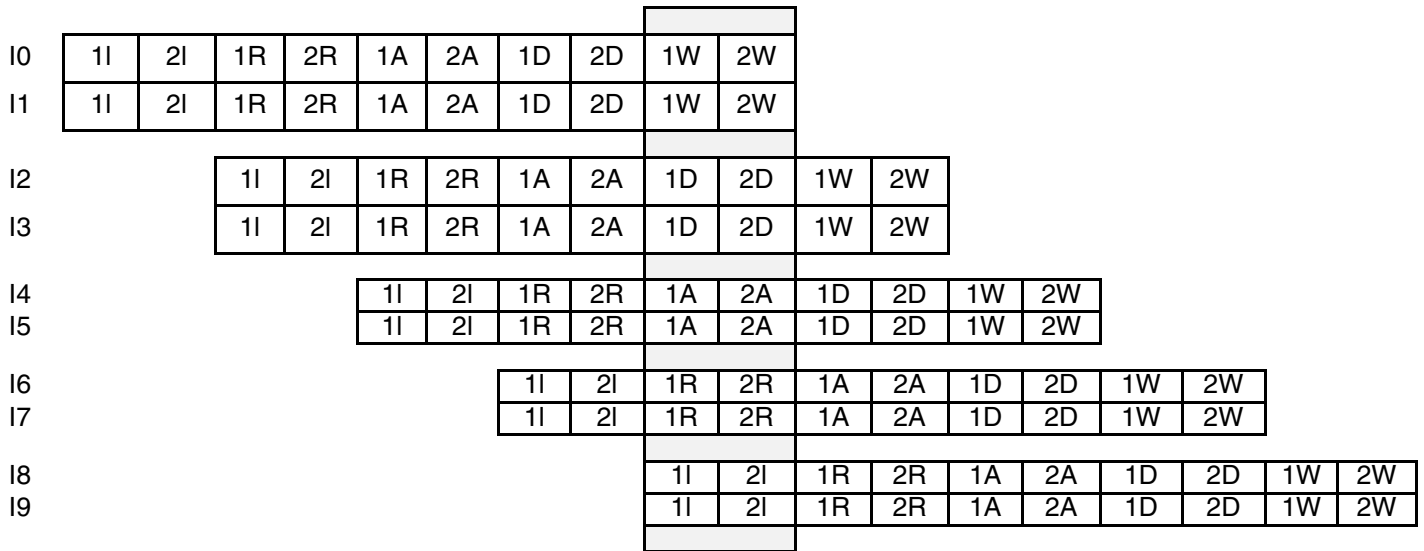

→ | one cycle | ←

- 1I-1R: Instruction cache access
- 2I: Instruction virtual to physical address translation
- 2R: Register file read, Bypass calculation, Instruction decode, Branch address calculation
- 1A: Issue or slip decision, Branch decision
- 1A: Data virtual address calculation
- 1A-2A: Integer add, logical, shift
- 2A: Store Align
- 2A-2D: Data cache access and load align
- 1D: Data virtual to physical address translation
- 2W: Register file write

**Figure 3 – Pipeline**

view of the processors operation however since the out-of-order completion of loads, stores, and long latency floating-point operations can result in there being even more instructions in process than what is shown.

Note that instruction dependencies, resource conflicts, and branches result in some of the instruction slots being occupied by NOPs.

### Integer Unit

Like the ACT 52xx family, the ACT 7000SC implements the MIPS IV Instruction Set Architecture, and is therefore fully upward compatible with applications that run on processors such as the R4650 and R4700 that implement the earlier generation MIPS III Instruction Set Architecture. Additionally, the ACT 7000SC includes two implementation specific instructions not found in the baseline MIPS IV ISA, but that are useful in the embedded market place. Described in detail in a later section of this datasheet, these instructions are integer multiply-accumulate and three-operand integer multiply.

The ACT 7000SC integer unit includes thirty-two general purpose 64-bit registers, the HI/LO result registers for the two-Pipeline operand integer multiply/divide operations, and the program counter, or PC. There are two separate execution units, one of which can execute function, or F, type instructions and one which can execute memory, or M, type instructions. See above for a description of the instruction types and the issue rules. As a special case, integer multiply/divide instructions as well as their corresponding MFHi and MFLo instructions can only be executed in the F type execution unit. Within each execution unit the operational characteristics are the same as on previous QED designs with single cycle ALU operations (add, sub, logical, shift), one cycle load delay, and an autonomous multiply/divide unit.

### Register File

The ACT 7000SC has thirty-two general purpose registers with register location (r0) hard wired to zero value. These registers are used for scalar integer operations and address calculation. In order to service the two integer execution units, the register file has four read ports and two write ports and is fully bypassed both within and between the two execution units to minimize operation latency in the pipeline.

### ALU

The ACT 7000SC has two complete integer ALU's each consisting of an integer adder/subtractor, a logic unit, and a shifter. Table 3 shows the functions performed by the ALU's for each execution unit. Each of these units is optimized to perform all operations in a single processor cycle.

**Table 3 – ALU Operations**

Unit	F Pipe	M Pipe
Adder	add, sub	add, sub, data address add
Logic	logic, moves, zero shifts (nop)	logic, moves, zero shifts (nop)
Shifter	non zero shift	non zero shift, store align

### Integer Multiply/Divide

The ACT 7000SC has a single dedicated integer multiply/divide unit optimized for high-speed multiply and multiply-accumulate operations. The multiply/divide unit resides in the F type execution unit. Table 4 shows the performance of the multiply/divide unit on each operation.

**Table 4 – Integer Multiply / Divide Operations**

Opcode	Operand Size	Latency	Repeat Rate	Stall Cycles
MULT/U, MAD/U	16 bit	4	3	0
	32 bit	5	4	0
MUL	16 bit	4	3	2
	32 bit	5	4	3
DMULT, DMULTU	any	9	8	0
DIV, DIVD	any	36	36	0
DDIV, DDIVU	any	68	68	0

The baseline MIPS IV ISA specifies that the results of a multiply or divide operation be placed in the Hi and Lo registers. These values can then be transferred to the general purpose register file using the Move-from-Hi and Move-from-Lo (MFHI/MFLO) instructions.

In addition to the baseline MIPS IV integer multiply instructions, the ACT 7000SC also implements the 3-operand multiply instruction, MUL. This instruction specifies that the multiply result go directly to the integer register file rather than the Lo register. The portion of the multiply that would have normally gone into the Hi register is discarded. For applications where it is known that the upper half of the multiply result is not required, using the MUL instruction eliminates the necessity of executing an explicit MFLO instruction.

Also included in the ACT 7000SC are the multiply-add instructions MAD/MADU. This instruction multiplies two operands and adds the resulting product to the current contents of the Hi and Lo registers. The multiply-accumulate operation is the core primitive of almost all signal processing algorithms allowing the ACT 7000SC to eliminate the need for a separate DSP engine in many embedded applications.

By pipelining the multiply-accumulate function and dynamically determining the size of the input operands, the ACT 7000SC is able to maximize throughput while still using an area efficient implementation.

### Floating-Point Coprocessor

The ACT 7000SC incorporates a high-performance fully pipe-lined floating-point coprocessor which includes a floating-point register file and autonomous execution units for multiply/ add/convert and divide/square root. The floating-point coprocessor is a tightly coupled co-execution unit, decoding and executing instructions in parallel with, and in the case of floating-point loads and stores, in cooperation with the M pipe of the integer unit. As described earlier, the superscalar capabilities of the ACT 7000SC allow floating-point computation instructions to issue concurrently with integer instructions.

### Floating-Point Unit

The ACT 7000SC floating-point execution unit supports single and double precision arithmetic, as specified in the IEEE Standard 754. The execution unit is broken into a separate divide/square root unit and a pipelined multiply/add unit. Overlap of divide/square root and multiply/add is supported.

The ACT 7000SC maintains fully precise floating-point exceptions while allowing both overlapped and pipelined operations. Precise exceptions are extremely important in object-oriented programming environments and highly desirable for debugging in any environment.

The floating-point unit's operation set includes floating-point add, subtract, multiply, multiply-add, divide, square root, reciprocal, reciprocal square root, conditional moves, conversion between fixed-point and floating-point format, conversion between floating-point formats, and floating-point compare. Table 5 gives the latencies of the floating-point instructions in internal processor cycles.

### Floating-Point General Register File

The floating-point general register file, FGR, is made up of thirty-two 64-bit registers. With the floating-point load and store double instructions, LDC1 and SDC1, the floating-point unit can take advantage of the 64-bit wide data cache and issue a floating-point coprocessor load or store double-word instruction in every cycle.

The floating-point control register file contains two registers; one for determining configuration and revision information for the coprocessor and one for control and status information. These registers are primarily used for diagnostic software, exception handling, state saving and restoring, and control of rounding modes.

**Table 5 – Floating Point Latencies and Repeat Rates**

Operation	Latency single/double	Repeat Rate single/double
fadd	4	1
fsub	4	1
fmult	4/5	1/2
fmadd	4/5	1/2
fmsub	4/5	1/2
fdiv	21/36	19/34
fsqrt	21/36	19/34
frecip	21/36	19/34
frsqrt	38/68	36/66
fcvt.s.d	4	1
fcvt.s.w	6	3
fcvt.s.l	6	3
fcvt.d.s	4	1
fcvt.d.w	4	1
fcvt.d.l	4	1
fcvt.w.s	4	1
fcvt.w.d	4	1
fcvt.l.s	4	1
fcvt.l.d	4	1
fcmp	1	1
fmov, fmovc	1	1
fabs, fneg	1	1

To support superscalar operations, the FGR has four read ports and two write ports, and is fully bypassed to minimize operation latency in the pipeline. Three of the read ports and one write port are used to support the combined multiply-add instruction while the fourth read and second write port allows a concurrent floating-point load or store and conditional moves.

### System Control Coprocessor (CP0)

The system control coprocessor (CP0) in the MIPS architecture is responsible for the virtual memory sub-system, the exception control system, and the diagnostics capability of the processor. In the MIPS architecture, the system control coprocessor (and thus the kernel software) is implementation dependent. For memory management, the ACT 7000SC CP0 is logically identical to that of the RM5200 Family and R5000. For interrupt exceptions and diagnostics, the ACT 7000SC is a superset of the RM5200 Family and R5000 implementing additional features described later in the sections on Interrupts, the Test/Breakpoint facility, and the Performance Counter facility.

The memory management unit controls the virtual memory system page mapping. It consists of an instruction address translation buffer, or ITLB, a data address translation buffer, or DTLB, a Joint TLB, or JTLB, and coprocessor registers used by the virtual memory mapping sub-system.

### System Control Coprocessor Registers

The ACT 7000SC incorporates all system control coprocessor (CP0) registers internally. These registers provide the path through which the virtual memory system's page mapping is examined and modified, exceptions are handled, and operating modes are controlled (kernel vs. user mode, interrupts enabled or disabled, cache features). In addition, the ACT 7000SC includes registers to implement a real-time cycle counting facility, to aid in cache and system diagnostics, and to assist in data error detection.

To support the non-blocking caches and enhanced interrupt handling capabilities of the ACT 7000SC, both the data and control register spaces of CP0 are supported by the ACT 7000SC. In the data register space, that is the space accessed using the MFC0 and MTC0 instructions, the ACT 7000SC supports the same registers as found in the RM5200, R4000 and R5000 families. In the control space, that is the space accessed by the previously unused CTC0 and CFC0 instructions, the ACT 7000SC supports five new registers. The first three of these new 32-bit registers support the enhanced interrupt handling capabilities and are the Interrupt Control, Interrupt Priority

Level Lo (IPLLO), and Interrupt Priority Level Hi (IPLHI) registers. These registers are described further in the section on interrupt handling. The other two registers, *Imprecise Error 1* and *Imprecise Error 2*, have been added to help diagnose bus errors which occur on non-blocking memory references.

Figure 4 shows the CP0 registers.

### Virtual to Physical Address Mapping

The ACT 7000SC provides three modes of virtual addressing:

- user mode
- supervisor mode
- kernel mode

This mechanism is available to system software to provide a secure environment for user processes. Bits in the CP0 Status register determine which virtual addressing mode is used. In the user mode, the ACT 7000SC provides a single, uniform virtual address space of 256GB (2GB in 32-bit mode).

When operating in the kernel mode, four distinct virtual address spaces, totalling 1024GB (4GB in 32-bit mode), are simultaneously available and are differentiated by the high-order bits of the virtual address.

The ACT 7000SC processor also supports a supervisor mode in which the virtual address space is 256.5GB (2.5GB in 32-bit mode), divided into three regions based on the high-order bits of the virtual address. Figure 5 shows the address space layout for 32-bit operation.

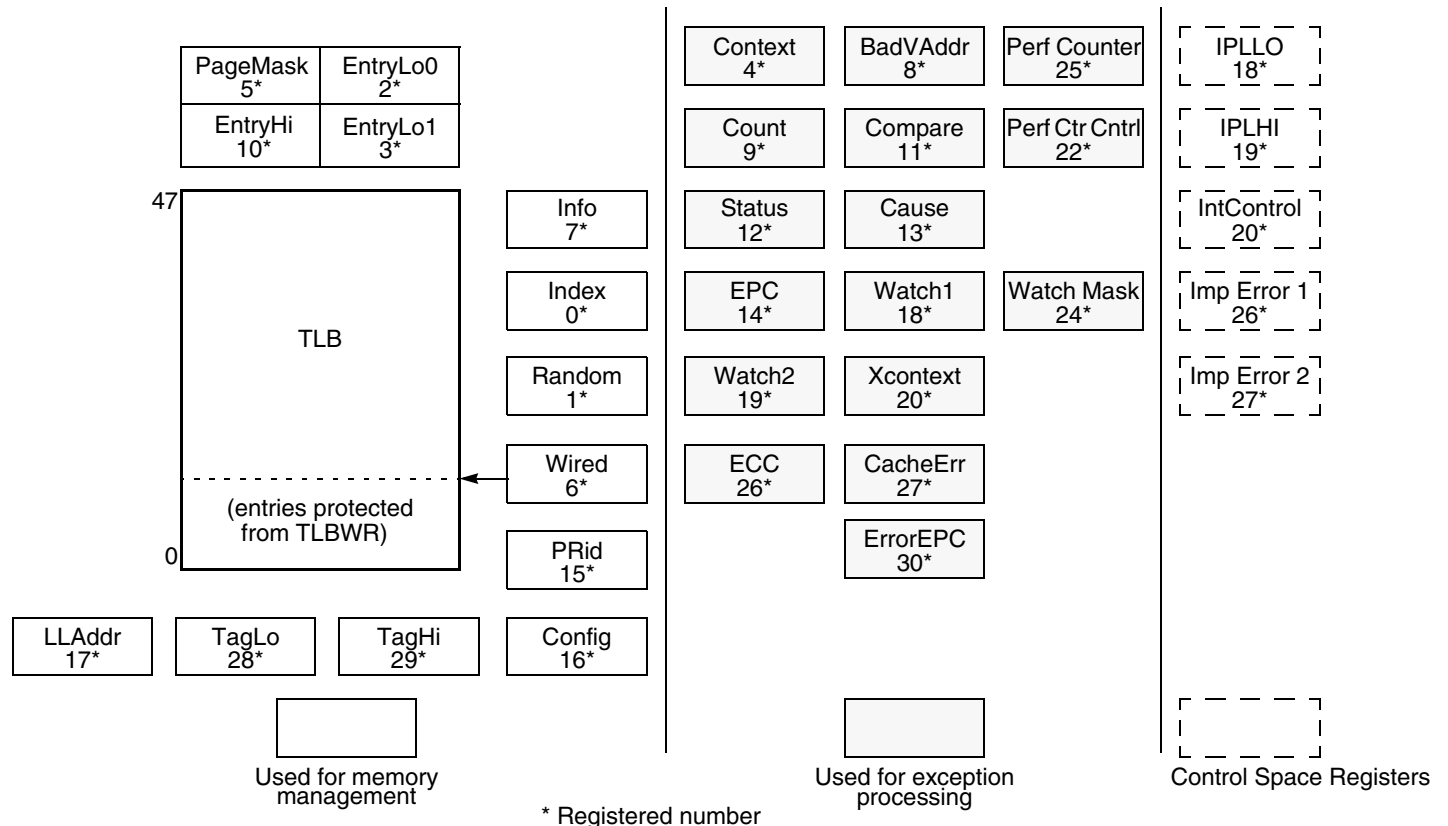

Figure 4 – CP0 Registers

**Figure 5 – Kernel Mode Virtual Addressing  
(32-bit mode)**

0xFFFFFFFF	Kernel virtual address space (kseg3) Mapped, 0.5GB
0xE0000000	
0xDFFFFFFF	Supervisor virtual address space (ksseg) Mapped, 0.5GB
0xC0000000	
0xBFFFFFFF	Uncached kernel physical address space (kseg1) Unmapped, 0.5GB
0xA0000000	
0x9FFFFFFF	Cached kernel physical address space (kseg0) Unmapped, 0.5GB
0x80000000	
0x7FFFFFFF	User virtual address space (kuseg) Mapped, 2.0GB
0x00000000	

When the ACT 7000SC is configured for 64-bit addressing, the virtual address space layout is an upward compatible extension of the 32-bit virtual address space layout.

### Joint TLB

For fast virtual-to-physical address translation, the ACT 7000SC uses a large, fully associative TLB that maps virtual pages to their corresponding physical addresses. As indicated by its name, the joint TLB (JTLB) is used for both instruction and data translations. The JTLB is organized as pairs of even/odd entries, and maps a virtual address and address space identifier into the large, 64GB physical address space. By default, the JTLB is configured as 48 pairs of even/odd entries. The 64 even/odd entry optional configuration is set at boot time.

Two mechanisms are provided to assist in controlling the amount of mapped space, and the replacement characteristics of various memory regions. First, the page size can be configured, on a per-entry basis, to use page sizes in the range of 4KB to 16MB (in 4X multiples). A

CP0 register, PageMask, is loaded with the desired page size of a mapping, and that size is stored into the TLB along with the virtual address when a new entry is written. Thus, operating systems can create special purpose maps; for example, a typical frame buffer can be memory mapped using only one TLB entry.

The second mechanism controls the replacement algorithm when a TLB miss occurs. The ACT 7000SC provides a random replacement algorithm to select a TLB entry to be written with a new mapping; however, the processor also provides a mechanism whereby a system specific number of mappings can be locked into the TLB, thereby avoiding random replacement. This mechanism allows the operating system to guarantee that certain pages are always mapped for performance reasons and for deadlock avoidance. This mechanism also facilitates the design of real-time systems by allowing deterministic access to critical software.

The JTLB also contains information that controls the cache coherency protocol for each page. Specifically, each page has attribute bits to determine whether the coherency algorithm is: uncached, write-back, write-through with write-allocate, write-through without write-allocate, write-back with secondary bypass. Note that both of the write-through protocols bypass the secondary cache since it does not support writes of less than a complete cache line.

These protocols are used for both code and data on the ACT 7000SC with data using write-back or write-through depending on the application. The write-through modes support the same efficient frame buffer handling as the RM5200 Family, R4700 and R5000.

### Instruction TLB

The ACT 7000SC uses a 4-entry instruction TLB (ITLB) to minimize contention for the JTLB, to eliminate the critical path of translating through a large associative array, and to save power. Each ITLB entry maps a 4KB page. The ITLB improves performance by allowing instruction address translation to occur in parallel with data address translation. When a miss occurs on an instruction address translation by the ITLB, the least-recently used ITLB entry is filled from the JTLB. The operation of the ITLB is completely transparent to the user.

### Data TLB

The ACT 7000SC uses a 4-entry data TLB (DTLB) for the same reasons cited above for the ITLB. Each DTLB entry maps a 4KB page. The DTLB improves performance by allowing data address translation to occur in parallel with instruction address translation. When a miss occurs on a data address translation by the DTLB, the DTLB is filled from the JTLB. The DTLB refill is pseudo-LRU: the least recently used entry of the least recently used pair of entries is filled. The operation of the DTLB is completely transparent to the user.

### Cache Memory

In order to keep the ACT 7000SC's superscalar pipeline full and operating efficiently, the ACT 7000SC has integrated primary instruction and data caches with single cycle access as well as a large unified secondary cache with



a three cycle miss penalty from the primaries. Each primary cache has a 64-bit read path, a 128-bit write path, and both caches can be accessed simultaneously. The primary caches provide the integer and floating-point units with an aggregate band-width of 3.6 GB per second at an internal clock frequency of 225 MHz. During an instruction or data primary cache refill, the secondary cache can provide a 64-bit datum every cycle following the initial three cycle latency for a peak bandwidth of 2.4 GB per second.

## Instruction Cache

The ACT 7000SC has an integrated 16KB, four-way set associative instruction cache and, even though instruction address translation is done in parallel with the cache access, the combination of 4-way set associativity and 16KB size results in a cache which is virtually indexed and physically tagged. Since the effective physical index eliminates the potential for virtual aliases in the cache, it is possible that some operating system code can be simplified as compared with the RM5200 Family, R5000 and R4000 class processors.

The data array portion of the instruction cache is 64 bits wide and protected by word parity while the tag array holds a 24-bit physical address, 14 housekeeping bits, a valid bit, and a single bit of parity protection.

By accessing 64 bits per cycle, the instruction cache is able to supply two instructions per cycle to the superscalar dispatch unit. For signal processing, graphics, and other numerical code sequences where a floating-point load or store and a floating-point computation instruction are being issued together in a loop, the entire bandwidth available from the instruction cache will be consumed by instruction issue. For typical integer code mixes, where instruction dependencies and other resource constraints restrict the achievable parallelism, the extra instruction cache bandwidth is used to fetch both the taken and non-taken branch paths to minimize the overall penalty for branches. A 32-byte (eight instruction) line size is used to maximize the communication efficiency between the instruction cache and the secondary cache, or memory system.

The ACT 7000SC is the first MIPS RISC microprocessor to support cache locking on a per line basis. The contents of each line of the cache can be locked by setting a bit in the Tag. Locking the line prevents its contents from being overwritten by a subsequent cache miss. Refill will occur only into unlocked cache lines. This mechanism allows the programmer to lock critical code into the cache thereby guaranteeing deterministic behavior for the locked code sequence.

## Data Cache

The ACT 7000SC has an integrated 16KB, four-way set associative data cache, and even though data address translation is done in parallel with the cache access, the combination of 4-way set associativity and 16KB size results in a cache which is physically indexed and physically tagged. Since the effective physical index eliminates the potential for virtual aliases in the cache, it is

possible that some operating system code can be simplified compared to the RM5200 Family, R5000 and R4000 class processors. The data cache is non-blocking; that is, a miss in the data cache will not necessarily stall the processor pipeline. As long as no instruction is encountered which is dependent on the data reference which caused the miss, the pipeline will continue to advance. Once there are two cache misses outstanding, the processor will stall if it encounters another load or store instruction. A 32-byte (eight word) line size is used to maximize the communication efficiency between the data cache and the secondary cache or memory system. The data array portion of the data cache is 64 bits wide and protected by byte parity while the tag array holds a 24-bit physical address, 3 housekeeping bits, a two bit cache state field, and has two bits of parity protection. The normal write policy is write-back, which means that a store to a cache line does not immediately cause memory to be updated. This increases system performance by reducing bus traffic and eliminating the bottleneck of waiting for each store operation to finish before issuing a subsequent memory operation. Software can, however, select write-through on a per-page basis when appropriate, such as for frame buffers. Cache protocols supported for the data cache are:

1. **Uncached.** Reads to addresses in a memory area identified as uncached will not access the cache. Writes to such addresses will be written directly to main memory without updating the cache.
2. **Write-back.** Loads and instruction fetches will first search the cache, reading the next memory hierarchy level only if the desired data is not cache resident. On data store operations, the cache is first searched to determine if the target address is cache resident. If it is resident, the cache contents will be updated, and the cache line marked for later write-back. If the cache lookup misses, the target line is first brought into the cache and then the write is performed as above.
3. **Write-through with write allocate.** Loads and instruction fetches will first search the cache, reading from memory only if the desired data is not cache resident; write-through data is never cached in the secondary cache. On data store operations, the cache is first searched to determine if the target address is cache resident. If it is resident, the primary cache contents will be updated and main memory will also be written leaving the write-back bit of the cache line unchanged; no writes will occur into the secondary. If the cache lookup misses, the target line is first brought into the cache and then the write is performed as above.
4. **Write-through without write allocate.** Loads and instruction fetches will first search the cache, reading from memory only if the desired data is not cache resident; write-through data is never cached in the secondary. On data store operations, the cache is first searched to determine if the target address is cache resident. If it is resident, the cache contents will be updated and main memory will also be written leaving the write-back bit of the cache line

unchanged; no writes will occur into the secondary. If the cache lookup misses, then only main memory is written.

5. **Write-back with secondary bypass.** Loads and instruction fetches first search the primary cache, reading from memory only if the desired data is not resident; the secondary is not searched. On data store operations, the primary cache is first searched to determine if the target address is resident. If it is resident, the cache contents are updated, and the cache line marked for later write-back. If the cache lookup misses, the target line is first brought into the cache and then the write is performed as above.

Associated with the Data Cache is the store buffer. When the ACT 7000SC executes a STORE instruction, this single-entry buffer gets written with the store data while the tag comparison is performed. If the tag matches, then the data is written into the Data Cache in the next cycle that the Data Cache is not accessed (the next non-load cycle). The store buffer allows the ACT 7000SC to execute a store every processor cycle and to perform back-to-back stores without penalty. In the event of a store immediately followed by a load to the same address, a combined merge and cache write will occur such that no penalty is incurred.

## Secondary Cache

The ACT 7000SC has an integrated 256KB, four-way set associative, block write-back secondary cache. The secondary has the same line size as the primaries, 32 bytes, is logically 64-bits wide matching the system interface and primary widths, and is protected with doubleword parity. The secondary tag array holds a 20-bit physical address, 2 housekeeping bits, a three bit cache state field, and two parity bits.

By integrating a secondary cache, the ACT 7000SC is able to dramatically decrease the latency of a primary cache miss without dramatically increasing the number of pins and the amount of power required by the processor. From a technology point of view, integrating a secondary cache maximally leverages CMOS semiconductor technology by using silicon to build the structures that are most amenable to silicon technology; silicon is being used to build very dense, low power memory arrays rather than large power hungry I/O buffers.

Further benefits of an integrated secondary are flexibility in the cache organization and management policies that are not practical with an external cache. Two previously

mentioned examples are the 4-way associativity and write-back cache protocol.

A third management policy for which integration affords flexibility is cache hierarchy management. With multiple levels of cache, it is necessary to specify a policy for dealing with cases where two cache lines at level n of the hierarchy would, if possible, be sharing an entry in level n+1 of the hierarchy. The policy followed by the ACT 7000SC is motivated by the desire to get maximum cache utility and results in the ACT 7000SC allowing entries in the primaries which do not necessarily have a corresponding entry in the secondary; the ACT 7000SC does not force the primaries to be a subset of the secondary. For example, if primary cache line A is being filled and a cache line already exists in the secondary for primary cache line B at the location where primary A's line would reside then that secondary entry will be replaced by an entry corresponding to primary cache line A and no action will occur in the primary for cache line B. This operation will create the aforementioned scenario where the primary cache line which initially had a corresponding secondary entry will no longer have such an entry. Such a primary line is called an orphan. In general, cache lines at level n+1 of the hierarchy are called parents of level n's children.

Another ACT 7000SC cache management optimization occurs for the case of a secondary cache line replacement where the secondary line is dirty and has a corresponding dirty line in the primary. In this case, since it is permissible to leave the dirty line in the primary, it is not necessary to write the secondary line back to main memory. Taking this scenario one step further, a final optimization occurs when the aforementioned dirty primary line is replaced by another line and must be written back, in this case, it will be written directly to memory bypassing the secondary cache.

## Secondary Caching Protocols

Unlike the primary data cache, the secondary cache supports only uncached and block write-back. As noted earlier, cache lines managed with either of the write-through protocols will not be placed in the secondary cache. A new caching attribute, write-back with secondary bypass, allows the secondary to be bypassed entirely. When this attribute is selected, the secondary will not be filled on load misses and will not be written on dirty write-backs from the primary.

**Table 6 – Cache Attributes**

Attribute	Instruction	Data	Secondary
Size	16KB	16KB	256KB
Associativity	4-way	4-way	4-way
Replacement Algorithm.	cyclic	cyclic	cyclic
Line size	32 byte	32 byte	32 byte

**Table 6 – Cache Attributes (cont)**

Attribute	Instruction	Data	Secondary
Index	vAddr 11..0	vAddr 11..0	pAddr 15..0
Tag	pAddr 35..12	pAddr 35..12	pAddr 35..16
Write policy	n.a.	write-back, write-through	block write-back, bypass
read policy	n.a.	non-blocking (2 outstanding)	non-blocking (data only, 2 outstanding)
read order	critical word first	critical word first	critical word first
write order	NA	sequential	sequential
miss restart following:	complete line	first double (if waiting for data)	n.a.
Parity	per word	per byte	per doubleword

**Cache Locking**

The ACT 7000SC allows critical code or data fragments to be locked into the primary and secondary caches. The user has complete control over what locking is performed with cache line granularity. For instruction and data fragments in the primaries, locking is accomplished by setting either or both of the cache lock enable bits in the CP0 ECC register, specifying the set via a field in the CP0 ECC register, and then executing either a load instruction or a Fill\_I cache operation for data or instructions respectively. Only two sets are lockable within each cache: set A and set B. Locking within the secondary works identically to the primaries using a separate secondary lock enable bit and the same set selection field. As with the primaries, only two sets are lockable: sets A and B. Table 7 summarizes the cache locking capabilities.

**Table 7 – Cache Locking Control**

Cache	Lock Enable	Set Select	Activate
Primary I	ECC[27]	ECC[28]=0→A ECC[28]=1→B	Fill_I
Primary D	ECC[26]	ECC[28]=0→A ECC[28]=1→B	Load/Store
Secondary	ECC[25]	ECC[28]=0→A ECC[28]=1→B	Fill_I or Load/Store

**Cache Management**

To improve the performance of critical data movement operations in the embedded environment, the ACT 7000SC significantly improves the speed of operation of certain critical cache management operations as compared with the R5000 and R4000 families. In particular, the speed of the Hit-Write-back-Invalidate and Hit-Invalidate cache operations has been improved in some cases by an order of magnitude over that of the earlier families. Table 8 compares the ACT 7000SC with the R4000 and R5000 processors.

**Table 8 – Penalty Cycle**

Operation	Condition	Penalty	
		ACT 7000SC	R4000/R5000
Hit-Writeback-Invalidate	Miss	0	7
	Hit-Clean	3	12
	Hit-Dirty	3+n	14+n
Hit-Invalidate	Miss	0	7
	Hit	2	9

For the Hit-Dirty case of Hit-Writeback-Invalidate, if the writeback buffer is full from some previous cache eviction then n is the number of cycles required to empty the write-back buffer. If the buffer is empty then n is zero.

The penalty value is the number of processor cycles beyond the one cycle required to issue the instruction that is required to implement the operation.

**Primary Write Buffer**

Writes to secondary cache or external memory, whether cache miss write-backs or stores to uncached or write-through addresses, use the integrated primary write buffer. The write buffer holds up to four 64-bit address and data pairs. The entire buffer is used for a data cache write-back and allows the processor to proceed in parallel with memory update. For uncached and write-through stores, the write buffer significantly increases performance by decoupling the SysAD bus transfers from the instruction execution stream.

**System Interface**

The ACT 7000SC provides a high-performance 64-bit system interface which is compatible with the RM5200 Family and R5000. Unlike the R4000 and R5000 family

processors which provide only an integral multiplication factor between SysClock and the pipeline clock, the ACT 7000SC also allows half-integral multipliers, thereby providing greater granularity in the designers choice of pipeline and system interface frequencies.

The interface consists of a 64-bit Address/Data bus with 8 check bits and a 9-bit command bus. In addition, there are six handshake signals and six interrupt inputs. The interface has a simple timing specification and is capable of transferring data between the processor and memory at a peak rate of 600 MB/sec with a 75 MHz SysClock.

Figure 6 shows a typical embedded system using the ACT 7000SC. This example shows a system with a bank of DRAMs, and an interface ASIC which provides DRAM control as well as an I/O port.

### System Address/Data Bus

The 64-bit System Address Data (SysAD) bus is used to transfer addresses and data between the ACT 7000SC and the rest of the system. It is protected with an 8-bit parity check bus, SysADC.

The system interface is configurable to allow easy interfacing to memory and I/O systems of varying frequencies. The data rate and the bus frequency at which the ACT 7000SC transmits data to the system interface are programmable via boot time mode control bits. Also, the rate at which the processor receives data is fully controlled by the external device. Therefore, either a low cost interface requiring no read or write buffering or a faster, high-performance interface can be designed to communicate with the ACT 7000SC. Again, the system designer has the flexibility to make these price/performance trade-offs.

### System Command Bus

The ACT 7000SC interface has a 9-bit System Command (SysCmd) bus. The command bus indicates whether the SysAD bus carries an address or data. If the SysAD bus carries an address, then the SysCmd bus also indicates what type of transaction is to take place (for example, a read or write). If the SysAD bus carries data, then the SysCmd bus also gives information about the data (for example, this is the last data word transmitted, or the data contains an error). The SysCmd bus is bidirectional to

support both processor requests and external requests to the ACT 7000SC. Processor requests are initiated by the ACT 7000SC and responded to by an external device. External requests are issued by an external device and require the ACT 7000SC to respond.

The ACT 7000SC supports one to eight byte and 32-byte block transfers on the SysAD bus. In the case of a sub-double-word transfer, the 3 low-order address bits give the byte address of the transfer, and the SysCmd bus indicates the number of bytes being transferred.

### Handshake Signals

There are six handshake signals on the system interface. Two of these, **RdRdy\*** and **WrRdy\***, are used by an external device to indicate to the ACT 7000SC whether it can accept a new read or write transaction. The ACT 7000SC samples these signals before deasserting the address on read and write requests.

**ExtRqst\*** and **Release\*** are used to transfer control of the SysAD and SysCmd buses from the processor to an external device. When an external device needs to control the interface, it asserts **ExtRqst\***. The ACT 7000SC responds by asserting **Release\*** to release the system interface to slave state.

**ValidOut\*** and **ValidIn\*** are used by the ACT 7000SC and the external device respectively to indicate that there is a valid command or data on the SysAD and SysCmd buses. The ACT 7000SC asserts **ValidOut\*** when it is driving these buses with a valid command or data, and the external device drives **ValidIn\*** when it has control of the buses and is driving a valid command or data.

### System Interface Operation

The ACT 7000SC can issue read and write requests to an external device, while an external device can issue null and write requests to the ACT 7000SC.

For processor reads, the ACT 7000SC asserts ValidOut\* and simultaneously drives the address and read command on the SysAD and SysCmd buses. If the system interface has **RdRdy\*** asserted, then the processor tristates its drivers and releases the system interface to slave state by asserting **Release\***. The external device can then begin sending data to the ACT 7000SC.

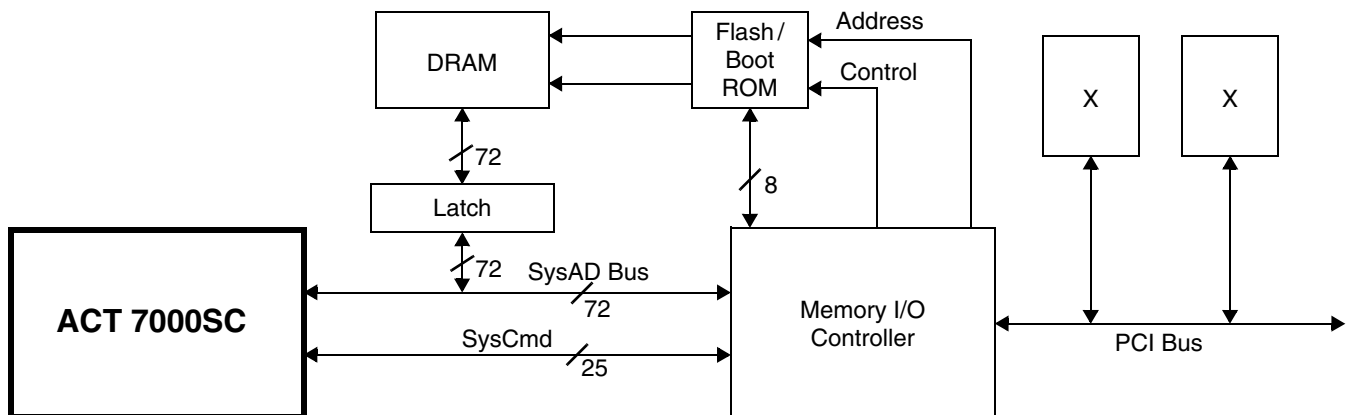

Figure 6 – Typical Embedded System Block Diagram

Figure 7 shows a processor block read request and the external agent read response for a system with a transaction.

The read latency is 4 cycles (**ValidOut\*** to **ValidIn\***), and the response data pattern is DDxxDD. Figure 8 shows a processor block write where the processor was programmed with write-back data rate boot code 2, or DDxxD-Dxx.

### Data Prefetch

The ACT 7000SC is the first Aeroflex design to support the MIPS IV integer data prefetch (PREF) and floating-point data prefetch (PREFX) instructions. These instructions are used by the compiler or by an assembly language programmer when it is known or suspected that an upcoming data reference is going to miss in the cache. By appropriately placing a prefetch instruction, the memory latency can be hidden under the execution of other instructions. If the execution of a prefetch instruction would cause a memory management or address error exception the prefetch is treated as a NOP.

The “Hint” field of the data prefetch instruction is used to specify the action taken by the instruction. The instruction can operate normally (that is, fetching data as if for a load operation) or it can allocate and fill a cache line with zeroes on a primary data cache miss.

### Enhanced Write Modes

The ACT 7000SC implements two enhancements to the original R4000 write mechanism: Write Reissue and Pipeline Writes. In write reissue mode, a write rate of one write every two bus cycles can be achieved. A write issues if **WrRdy\*** is asserted two cycles earlier and is still asserted during the issue cycle. If it is not still asserted then the last write will reissue. Pipe-lined writes have the same two bus cycle write repeat rate, but can issue one additional write following the deassertion of **WrRdy\***.

### External Requests

The ACT 7000SC can respond to certain requests issued by an external device. These requests take one of two forms: Write requests and Null requests. An external device executes a write request when it wishes to update one of the processors writable resources such as the internal interrupt register. A null request is executed when the

external device wishes the processor to reassert ownership of the processor external interface. Typically a null request will be executed after an external device, that has acquired control of the processor interface via **ExtRqst\***, has completed an independent transaction between itself and system memory in a system where memory is connected directly to the SysAD bus. Normally this transaction would be a DMA read or write from the I/O system.

### Test/Breakpoint Registers

To increase both observability and controllability of the processor thereby easing hardware and software debugging, a pair of Test/Break-point, or Watch, registers, Watch1 and Watch2, have been added to the ACT 7000SC. Each Watch register can be separately enabled to watch for a load address, a store address, or an instruction address. All address comparisons are done on physical addresses. An associated register, Watch Mask, has also been added so that either or both of the Watch registers can compare against an address range rather than a specific address. The range granularity is limited to a power of two.

When enabled, a match of either Watch register results in an exception. If the Watch is enabled for a load or store address then the exception is the Watch exception as defined for the R4000 with Cause exception code twenty-three. If the Watch is enabled for instruction addresses then a newly defined Instruction Watch exception is taken and the Cause code is sixteen. The Watch register which caused the exception is indicated by Cause bits 25..24.

Table 9 summarizes a Watch operation.

**Table 9 – Watch Control Register**

Register	Bit Field/Function					
	63	62	61	60:36	35:2	1:0
Watch1, 2	Store	Load	Instr	0	Addr	0
	31:2				1	0
Watch Mask	Mask				Mask Watch 2	Mask Watch 1

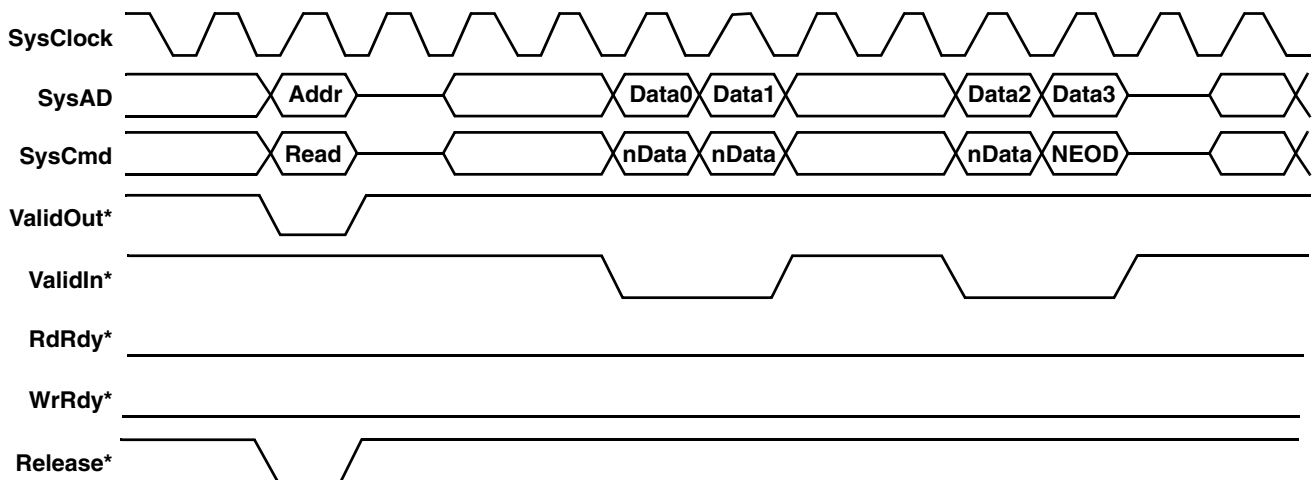

**Figure 7 – Processor Block Read**

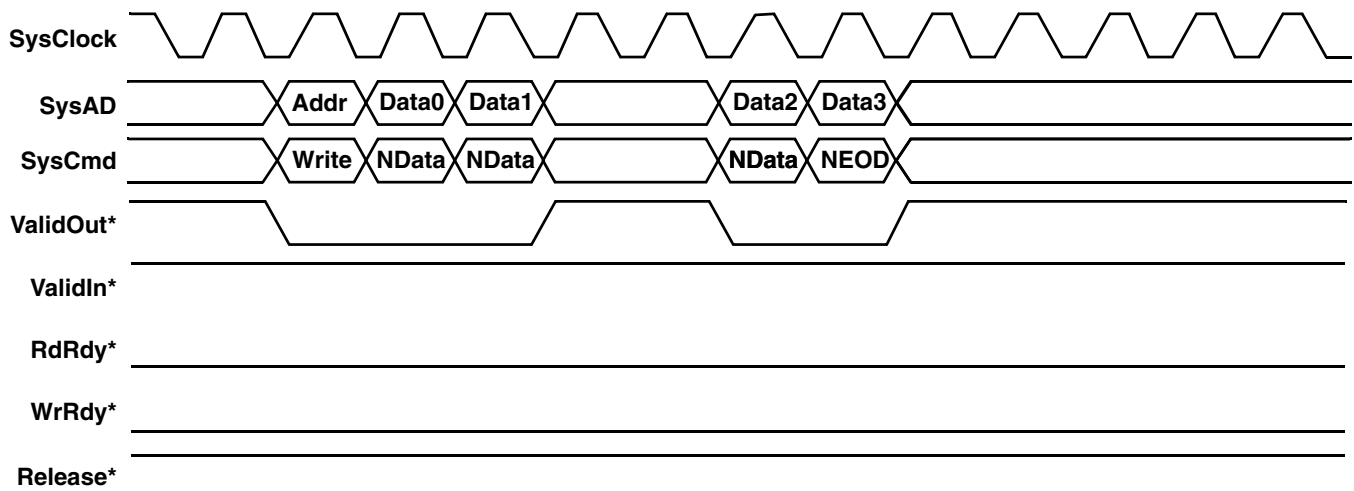

**Figure 8 – Processor Block Write**

**Performance Counters**

Like the Test/Break-point capability described above, the Performance Counter feature has been added to improve the observability and controllability of the processor thereby easing system debug and, especially in the case of the performance counters, easing system tuning.

The Performance Counter feature is implemented using two new CP0 registers, PerfCount and PerfControl. The PerfCount register is a 32-bit writable counter which causes an interrupt when bit 31 is set. The PerfControl register is a 32-bit register containing a five bit field which selects one of twenty-two event types as well as a handful of bits which control the overall counting function. Note that only one event type can be counted at a time and that counting can occur for user code, kernel code, or both. The event types and control bits are listed in Table 10.

**Table 10 – Performance Counter Control**

PerfControl Field	Description
4..0	Event Type 00: Clock cycles 01: Total instructions issued 02: Floating-point instructions issued 03: Integer instructions issued 04: Load instructions issued 05: Store instructions issued 06: Dual issued pairs 07: Branch prefetches 08: External Cache Misses 09: Stall cycles 0A: Secondary cache misses 0B: Instruction cache misses 0C: Data cache misses 0D: Data TLB misses 0E: Instruction TLB misses 0F: Joint TLB instruction misses 10: Joint TLB data misses

**Table 10 – Performance Counter Control (cont)**

PerfControl Field	Description
	11: Branches taken 12: Branches issued 13: Secondary cache writebacks 14: Primary cache writebacks 15: Dcache miss stall cycles (cycles where both cache miss tokens taken and a third address is requested) 16: Cache misses 17: FP possible exception cycles 18: Slip Cycles due to multiplier busy 19: Coprocessor 0 slip cycles 1A: Slip cycles due to pending non-blocking loads 1B: Write buffer full stall cycles 1C: Cache instruction stall cycles 1D: Multiplier stall cycles 1E: Stall cycles due to pending non-blocking loads - stall start of exception
7..5	Reserved (must be zero)
8	Count in Kernel Mode 0: Disable 1: Enable
9	Count in User Mode 0: Disable 1: Enable
10	Count Enable 0: Disable 1: Enable
31..11	Reserved (must be zero)

The performance counter interrupt will only occur when interrupts are enabled in the Status register, IE=1, and Interrupt Mask bit 13 (IM[13]) of the coprocessor 0 interrupt control register is not set.

Since the performance counter can be set up to count clock cycles, it can be used as either a) a second timer or b) a watchdog interrupt. A watchdog interrupt can be used as an aid in debugging system or software “hangs.” Typically the software is setup to periodically update the count so that no interrupt will occur. When a hang occurs the interrupt ultimately triggers thereby breaking free from the hang-up.

## Interrupt Handling

In order to provide better real time interrupt handling, the ACT 7000SC provides an extended set of hardware interrupts each of which can be separately prioritized and separately vectored.

As described above, the performance counter is also a hardware interrupt source, **IP[13]**. Also, whereas the R4000 and R5000 family processors map the timer interrupt onto **IP[7]**, the ACT 7000SC provides a separate interrupt, **IP[12]**, for this purpose.

All of these interrupts, **IP[13..0]**, the Performance Counter, and the Timer, have corresponding interrupt mask bits, **IM[13..0]**, and interrupt pending bits, **IP[13..0]**, in the Status, Interrupt Control, and Cause registers. The bit assignments for the Interrupt Control and Cause registers are shown in Table 11 and Table 12 below. The Status register has not changed from the RM5200 Family and R5000, and is not shown.

The IV bit in the Cause register is the global enable bit for the enhanced interrupt features. If this bit is clear then interrupt operation is compatible with the RM5200 Family and R5000. Although not related to the interrupt mechanism, note that the W1 and W2 bits indicate which Watch register caused a particular Watch exception.

In the Interrupt Control register, the interrupt vector spacing is controlled by the Spacing field as described below. The Interrupt Mask field (**IM[15..8]**) contains the interrupt mask for interrupts eight through thirteen. **IM[15..14]** are reserved for future use. The Timer Exclusive (TE) bit if set moves the Timer interrupt to **IP[12]**. If clear, the Timer interrupt will be or’ed into **IP[7]** as on the R5000.

The Interrupt Control register uses **IM13** to enable the Performance Counter Control.

Priority of the interrupts is set via two new coprocessor 0 registers called Interrupt Priority Level Lo, **IPLLO**, and Interrupt Priority Level Hi, **IPLHI**.

These two registers contain a four-bit field corresponding to each interrupt thereby allowing each interrupt to be programmed with a priority level from 0 to 13 inclusive. The priorities can be set in any manner including having all the priorities set exactly the same. Priority 0 is the highest level and priority 15 the lowest. The format of the priority level registers is shown in Table 13 and Table 14 below. The priority level registers are located in the coprocessor 0 control register space. For further details about the control space see the section describing coprocessor 0.

In addition to programmable priority levels, the ACT 7000SC also permits the spacing between interrupt vectors to be programmed. For example, the minimum spacing between two adjacent vectors is 0x20 while the maximum is 0x200. This programmability allows the user to either set

up the vectors as jumps to the actual interrupt routines or, if interrupt latency is paramount, to include the entire interrupt routine at the vector. Table 15 illustrates the complete set of vector spacing selections along with the coding as required in the Interrupt Control register bits 4:0.

In general, the active interrupt priority combined with the spacing setting generates a vector offset which is then added to the interrupt base address of 0x200 to generate the interrupt exception offset. This offset is then added to the exception base to produce the final interrupt vector address.

**Table 15 – Interrupt Vector Spacing**

<b>ICR[4..0]</b>	<b>Spacing</b>
0x0	0x000
0x1	0x020
0x2	0x040
0x4	0x080
0x8	0x100
0x10	0x200
others	reserved

## Standby Mode

The ACT 7000SC provides a means to reduce the amount of power consumed by the internal core when the CPU would not otherwise be performing any useful operations. This state is known as Standby Mode.

Executing the WAIT instruction enables interrupts and enters Standby Mode. When the WAIT instruction completes the W pipe stage, if the SysAD bus is currently idle, the internal processor clocks will stop thereby freezing the pipeline. The phase lock loop, or PLL, internal timer/counter, and the “wake up” input pins: **IP[5:0]\***, **NMI\***, **ExtReq\***, **Reset\***, and **ColdReset\*** continue to operate in their normal fashion. If the SysAD bus is not idle when the WAIT instruction completes the W pipe stage, then the WAIT is treated as a NOP. Once the processor is in Standby, any interrupt, including the internally generated timer interrupt, will cause the processor to exit Standby and resume operation where it left off. The WAIT instruction is typically inserted in the idle loop of the operating system or real time executive.

## JTAG Interface

The ACT 7000SC interface supports JTAG boundary scan in conformance with IEEE 1149.1. The JTAG interface is especially helpful for checking the integrity of the processor’s pin connections.

**Table 11 – Cause Register**

<b>31</b>	<b>30</b>	<b>29,28</b>	<b>27</b>	<b>26</b>	<b>25</b>	<b>24</b>	<b>23..8</b>	<b>7</b>	<b>6..2</b>	<b>0,1</b>
BD	0	CE	0	W2	W1	IV	IP[15..0]	0	EXC	0

**Table 12 – Interupt Control Register**

<b>31..16</b>	<b>15..8</b>	<b>7</b>	<b>6..5</b>	<b>4..00</b>
0	IM[15..8]	TE	0	Spacing

**Table 13 – IPLLO Register**

<b>31..28</b>	<b>27..24</b>	<b>23..20</b>	<b>19..16</b>	<b>15..12</b>	<b>11..8</b>	<b>7..4</b>	<b>3..0</b>
IPL7	IPL6	IPL5	IPL4	IPL3	IPL2	IPL1	IPL0

**Table 14 – IPLHI Register**

<b>31..28</b>	<b>27..24</b>	<b>23..20</b>	<b>19..16</b>	<b>15..12</b>	<b>11..8</b>	<b>7..4</b>	<b>3..0</b>
0	0	IPL13	IPL12	IPL11	IPL10	IPL9	IPL8

### Boot-Time Options

Fundamental operational modes for the processor are initialized by the boot-time mode control interface. The boot-time mode control interface is a serial interface operating at a very low frequency (**SysClock** divided by 256). The low frequency operation allows the initialization information to be kept in a low cost EPROM; alternatively the twenty or so bits could be generated by the system interface ASIC.

Immediately after the **VccOK** signal is asserted, the processor reads a serial bit stream of 256 bits to initialize all the fundamental operational modes. **ModeClock** runs continuously from the assertion of **VccOK**.



## Boot-Time Modes

The boot-time serial mode stream is defined in Table 16. Bit 0 is the bit presented to the processor when **VccOK** is deasserted; bit 255 is the last.

**Table 16 – Boot Time Mode Stream**

Mode bit	Description
0	Reserved: Must be zero
4..1	Write-back data rate 0: DDDD 1: DDxDDx 2: DDxxDDxx 3: DxDxDxDx 4: DDxxxDDxxx 5 DDxxxxDDxxxx 6: DxxDxxDxxDxx 7: DDxxxxxxDDxxxxxx 8: DxxxDxxxDxxxDxxx 9-15:Reserved
7..5	SysClock to Pclock Multiplier Mode bit 20 = 0 / Mode bit 20 = 1 0: Multiply by 2/x 1: Multiply by 3/x 2: Multiply by 4/x 3: Multiply by 5/2.5 4: Multiply by 6/x 5: Multiply by 7/3.5 6: Multiply by 8/x 7: Multiply by 9/4.5
8	Specifies byte ordering. Logically ORed with BigEndian input signal. 0: Little endian 1: Big endian
10..9	Non-Block Write Control 00: R4000 compatible non-block writes 01: Reserved

**Table 16 – Boot Time Mode Stream (cont)**

Mode bit	Description
10..9 con't	10: pipelined non-block writes 11: non-block write re-issue
11	Timer Interrupt Enable/Disable 0: Enable the timer interrupt on IP[5] 1: Disable the timer interrupt on IP[5]
12	Reserved: Must be zero
14..13	Output driver strength - 100% = fastest 00: 67% strength 01: 50% strength 10: 100% strength 11: 83% strength
15	Reserved must be zero
17..16	System configuration identifiers - software visible in processor Config[21..20] register
19..18	Reserved: Must be zero
20	Pclock to SysClock multipliers. 0: Integer multipliers (2,3,4,5,6,7,8,9) 1: Half integer multipliers (2.5,3.5,4.5)
21	External Bus Width. 0: 64-bit 1: 32-bit
23..22	Reserved: Must be zero
24	JTLB Size. 0: 48 dual-entry 1: 64 dual-entry
25	On-chip secondary cache control. 0: Disable 1: Enable
255..26	Reserved: Must be zero

## PLL Analog Power Filtering

The ACT 7000SC includes extra PLL Analog Power Filtering circuitry designed to provide low noise, temperature stable filtering for the VccP and VssP signals. The included circuitry consists of several passive components located at the closest possible point to the RM7000 die and is configured as shown in Figure 9.

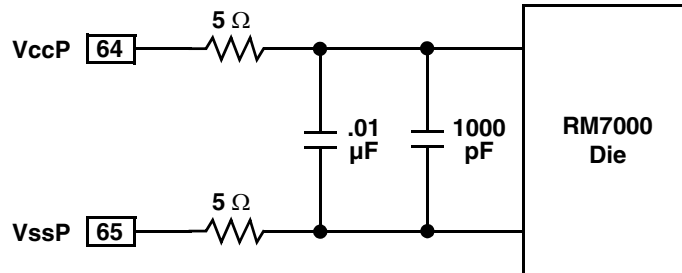

**Figure 9 – ACT 7000SC Including PLL Filter Circuit**

Additional board level PPL filtering is also required. The recommended configuration is shown in Figure 10.

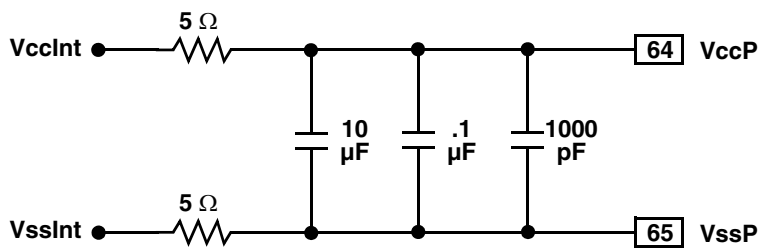

**Figure 10 – Recommended Board Level PLL Filter circuit for the ACT 7000SC**

## Absolute Maximum Rating<sup>1</sup>

Symbol	Parameter	Limits	Units
V <sub>TERM</sub>	Terminal Voltage with respect to V <sub>SS</sub>	-0.5 <sup>2</sup> to +3.9	V
T <sub>C</sub>	Case Operating Temperature	-55 to +125	°C
T <sub>STG</sub>	Storage Temperature	-65 to +150	°C
I <sub>IN</sub>	DC Input Current	20 <sup>3</sup>	mA
I <sub>OUT</sub>	DC Output Current <sup>4</sup>	50	mA

Note 1: Stresses greater than those listed under ABSOLUTE MAXIMUM RATINGS may cause permanent damage to the device. This is a stress rating only and functional operation of the device at these or any other conditions above those indicated in the operational sections of this specification is not implied. Exposure to absolute maximum rating conditions for extended periods may affect reliability.

Note 2: V<sub>IN</sub> minimum = -2.0V for pulse width less than 15ns. V<sub>IN</sub> should not exceed 3.9 Volts.

Note 3: When V<sub>IN</sub> < 0V or V<sub>IN</sub> > V<sub>CCIO</sub>

Note 4: Not more than one output should be shorted at a time. Duration of the short should not exceed 30 seconds.

## Recommended Operating Conditions

CPU Speed	Temperature	V <sub>SS</sub>	V <sub>SSInt</sub>	V <sub>CCIO</sub>	V <sub>CCP</sub>
150 - 225 MHz	-55°C to +125°C (T <sub>C</sub> )	0V	2.5V ±5%	3.3V ±5%	2.5V ±5%

Note: V<sub>CC</sub> I/O should not exceed V<sub>CCInt</sub> by greater than 1.2V during the power-up sequence.

Note: Applying a logic high state to any I/O pin before V<sub>CCInt</sub> becomes stable is not recommended.

Note: As specified in IEEE 1149.1 (JTAG), the JTMS pin must be held low during reset to avoid entering JTAG test mode. Refer to the RM7000 Family Users Manual, Appendix E.

## DC Electrical Characteristics

Parameter	Minimum	Maximum	Conditions
V <sub>OL</sub>		0.1V	I <sub>OUT</sub>   = 20µA
V <sub>OH</sub>	V <sub>CCIO</sub> - 0.1V		
V <sub>OL</sub>		0.4V	I <sub>OUT</sub>   = 4mA
V <sub>OH</sub>	2.4V		
V <sub>IL</sub>	-0.5V	0.2 x V <sub>CCIO</sub>	
V <sub>IH</sub>	0.7 x V <sub>CCIO</sub>	V <sub>CCIO</sub> + 0.5V	
I <sub>IN</sub>		±20µA ±20µA	V <sub>IN</sub> = 0 V <sub>IN</sub> = V <sub>CCIO</sub>
C <sub>IN</sub>		10pF	
C <sub>OUT</sub>		10pF	

## Power Consumption

Parameter		Condition	CPU Clock Speed							
			150 MHz		200 MHz		210 MHz		225 MHz	
			Typ <sup>1</sup>	Max <sup>2</sup>	Typ <sup>1</sup>	Max <sup>2</sup>	Typ <sup>1</sup>	Max <sup>2</sup>	Typ <sup>1</sup>	Max <sup>2</sup>
VccInt Power (mWatts)	Standby	No SysAD bus activity		500		1000		1500		2000
	Active	R4000 write protocol with no FPU operation (integer Instruction only)	2200	4400	2700	5400	2800	5600	3800	7600
		Write re-issue or pipelined writes with superscalar (integer and floating point instructions)	2550	5100	3150	6300	3300	6600	4250	8500

Note 1: Typical integer instruction mix and cache miss rates with worst case supply voltage.

Note 2: Worst case instruction mix with worst case supply voltage.

Note: I/O supply power is application dependant, but typically <10% of VccInt.

## AC Electrical Characteristics – Clock Parameters

Parameter	Symbol	Test Condition	CPU Clock Speed								Units
			150 MHz		200 MHz		210 MHz		225 MHz		
			Min	Max	Min	Max	Min	Max	Min	Max	
SysClock High	tSCHIGH	Transition $\leq$ 5ns	3		3		3		3		ns
SysClock Low	tSLOW	Transition $\leq$ 5ns	3		3		3		3		ns
SysClock Frequency			25	75	25	75	25	70	25	75	MHz
SysClock Period	tSCP			40		40		40		40	ns
Clock Jitter for SysClock	tJITTERIN			$\pm$ 200		$\pm$ 200		$\pm$ 150		$\pm$ 150	ps
SysClock Rise Time	tSCRISE			2		2		2		2	ns
SysClock Fall Time	tSCFALL			2		2		2		2	ns
ModeClock Period	tMODECKP			256		256		256		256	tSCP
JTAG Clock Period	tJTAGCKP			4		4		4		4	tSCP

Note: Operation of the ACT 7000 is only guaranteed with the Phase Lock Loop enabled

## System Interface Parameters

Parameter <sup>8</sup>	Sym	Test Conditions	150MHz		200MHz		210MHz		225MHz		Units
			Min	Max	Min	Max	Min	Max	Min	Max	
Data Output <sup>2,3</sup>	$t_{DO}$	mode <sub>14...13</sub> = 10 (fastest)	1.0	6.0	1.0	6.0	1.0	5.5	1.0	5.5	ns
		mode <sub>14...13</sub> = 11	1.0	6.5	1.0	6.5	1.0	6.0	1.0	6.0	ns
		mode <sub>14...13</sub> = 00	1.0	7.0	1.0	7.0	1.0	6.5	1.0	6.5	ns
		mode <sub>14...13</sub> = 01 (slowest)	1.0	7.5	1.0	7.5	1.0	7.0	1.0	7.0	ns
Data Setup <sup>4</sup>	$t_{DS}$	$t_{rise} = \text{see above table}$	2.5		2.5		2.5		2.5		ns
Data Hold <sup>4</sup>	$t_{DH}$	$t_{fall} = \text{see above table}$	1.0		1.0		1.0		1.0		ns

Notes:

1. Timings are measured from 1.5V of the clock to 1.5V of the signal.
2. Capacitive load for all output timings is 50pF.
3. Data Output timing applies to all signal pins whether tristate I/O or output only.
4. Setup and Hold parameters apply to all signal pins whether tristate I/O or input only.

## Boot-Time Interface Parameters

Parameter	Symbol	Test Conditions	Min	Max	Units
Mode Data Setup	$t_{DS}$		4		SysClock cycles
Mode Data Hold	$t_{DH}$		0		SysClock cycles

### Clock Timing

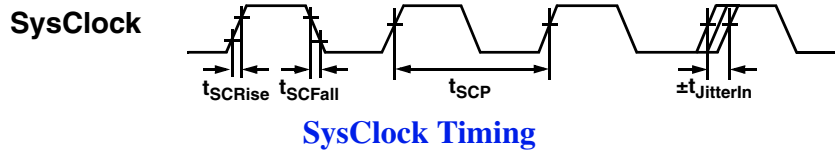

### System Interface Timing (SysAD, SysCmd, ValidIn\*, ValidOut\*, etc.)

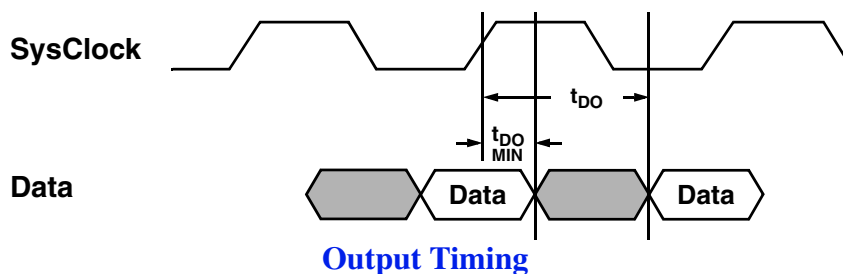
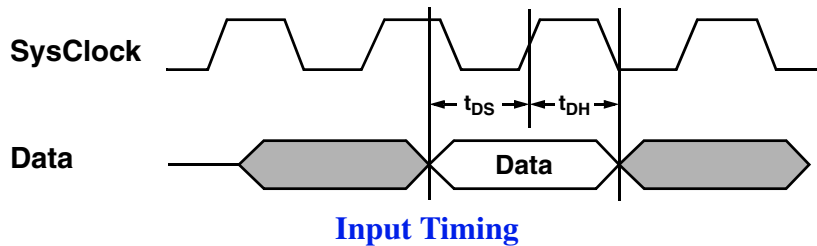

## Pin Descriptions

The following is a list of control, data, clock, interrupt, and miscellaneous pins of the ACT 7000SC.

Pin Name	Type	Description
System interface:		
ExtRqst*	Input	External request Signals that the system interface is submitting an external request.
Release*	Output	Release interface Signals that the processor is releasing the system interface to slave state
RdRdy*	Input	Read Ready Signals that an external agent can now accept a processor read.
WrRdy*	Input	Write Ready Signals that an external agent can now accept a processor write request.
ValidIn*	Input	Valid Input Signals that an external agent is now driving a valid address or data on the SysAD bus and a valid command or data identifier on the SysCmd bus.
ValidOut*	Output	Valid output Signals that the processor is now driving a valid address or data on the SysAD bus and a valid command or data identifier on the SysCmd bus.
SysAD(63:0)	Input/ Output	System address/data bus A 64-bit address and data bus for communication between the processor and an external agent.
SysADC(7:0)	Input/ Output	System address/data check bus An 8-bit bus containing parity check bits for the SysAD bus during data cycles.
SysCmd(8:0)	Input/ Output	System command/data identifier bus A 9-bit bus for command and data identifier transmission between the processor and an external agent.
SysCmdP	Input/ Output	System Command/Data Identifier Bus Parity For the RM7000, unused on input and zero on output.
Clock/Control interface:		
SysClock	Input	System clock Master clock input used as the system interface reference clock. All output timings are relative to this input clock. Pipeline operation frequency is derived by multiplying this clock up by the factor selected during boot initialization
VccP	Input	Vcc for PLL Quiet VccInt for the internal phase locked loop. Must be connected to VccInt. See Figure 10 for additional PPL filtering information.
VssP	Input	Vss for PLL Quiet Vss for the internal phase locked loop. Must be connected to Vss. See Figure 10 for additional PPL filtering information.
Interrupt Interface		
Int*(5:0)	Input	Interrupt Six general processor interrupts, bit-wise ORed with bits 5:0 of the interrupt register.
NMI*	Input	Non-maskable interrupt Non-maskable interrupt, ORed with bit 15 of the interrupt register (bit 7 in R5000 compatibility mode).

### Pin Descriptions (cont)

The following is a list of control, data, clock, interrupt, and miscellaneous pins of the ACT 7000SC.

Pin Name	Type	Description
JTAG interface:		
JTDI	Input	JTAG data in JTAG serial data in.
JTCK	Input	JTAG clock input JTAG serial clock input.
JTDO	Output	JTAG data out JTAG serial data out.
JTMS	Input	JTAG command JTAG command signal, signals that the incoming serial data is command data.
Initialization Interface:		
BigEndian	Input	Big Endian / Little Endian Control Allows the system to change the processor addressing mode without rewriting the mode ROM.
VccOK	Input	Vcc is OK When asserted, this signal indicates to the ACT 7000 that the 2.5V power supply has been above 2.25V for more than 100 milliseconds and will remain stable. The assertion of VccOK initiates the reading of the boot-time mode control serial stream.
ColdReset*	Input	Cold Reset This signal must be asserted for a power on reset or a cold reset. ColdReset must be de-asserted synchronously with SysClock.
Reset*	Input	Reset This signal must be asserted for any reset sequence. It may be asserted synchronously or asynchronously for a cold reset, or synchronously to initiate a warm reset. Reset must be de-asserted synchronously with SysClock.
ModeClock	Output	Boot Mode Clock Serial boot-mode data clock output at the system clock frequency divided by two hundred and fifty six.
ModeIn	Input	Boot Mode Data In Serial boot-mode data input.

*For additional Detail Information regarding the operation of the PMC-Sierra see the latest PMC-Sierra datasheet for the RM7000™ 64-Bit Superscalar Microprocessor with On-Chip Secondary Cache (doc. # PMC-2002175), Issue No. 1: January, 2001*

## Package Information – "F17" – CQFP 208 Leads

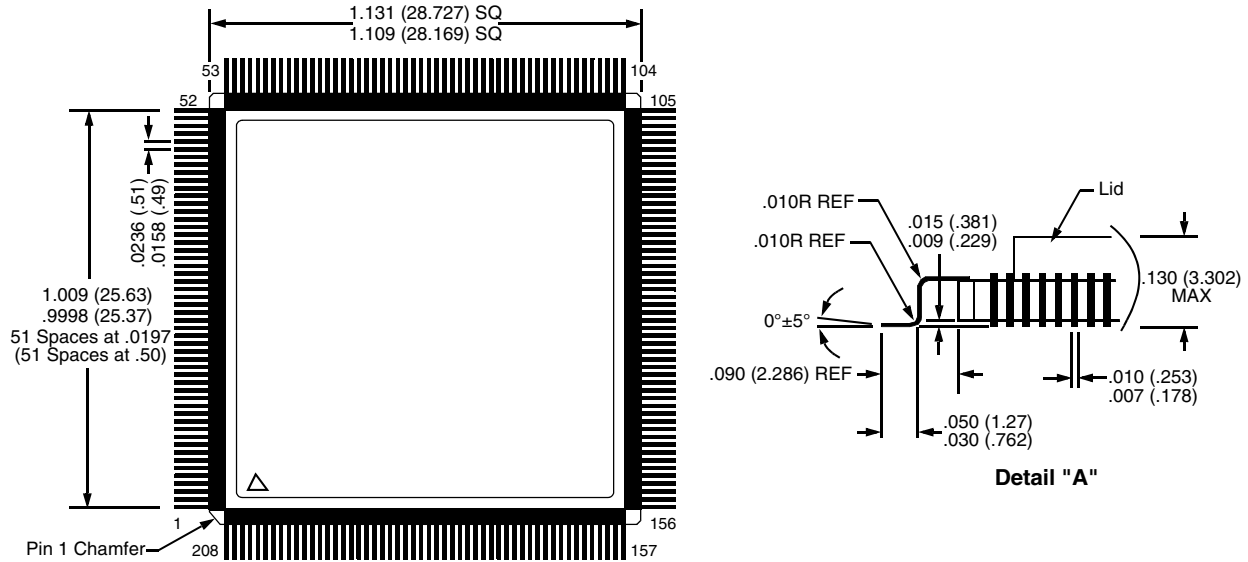

**Detail "A"**

Units: Inches (Millimeters)

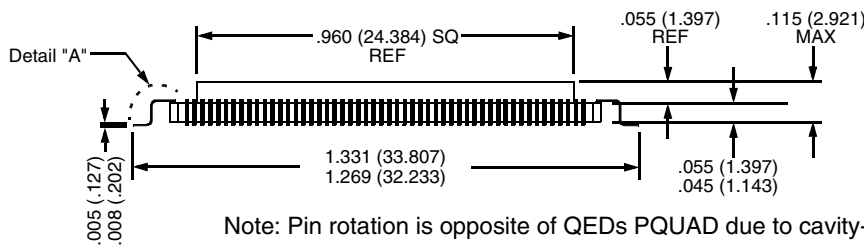

Note: Pin rotation is opposite of QEDs PQUAD due to cavity-up construction.

## Package Information – "F24" – Inverted CQFP 208 Leads

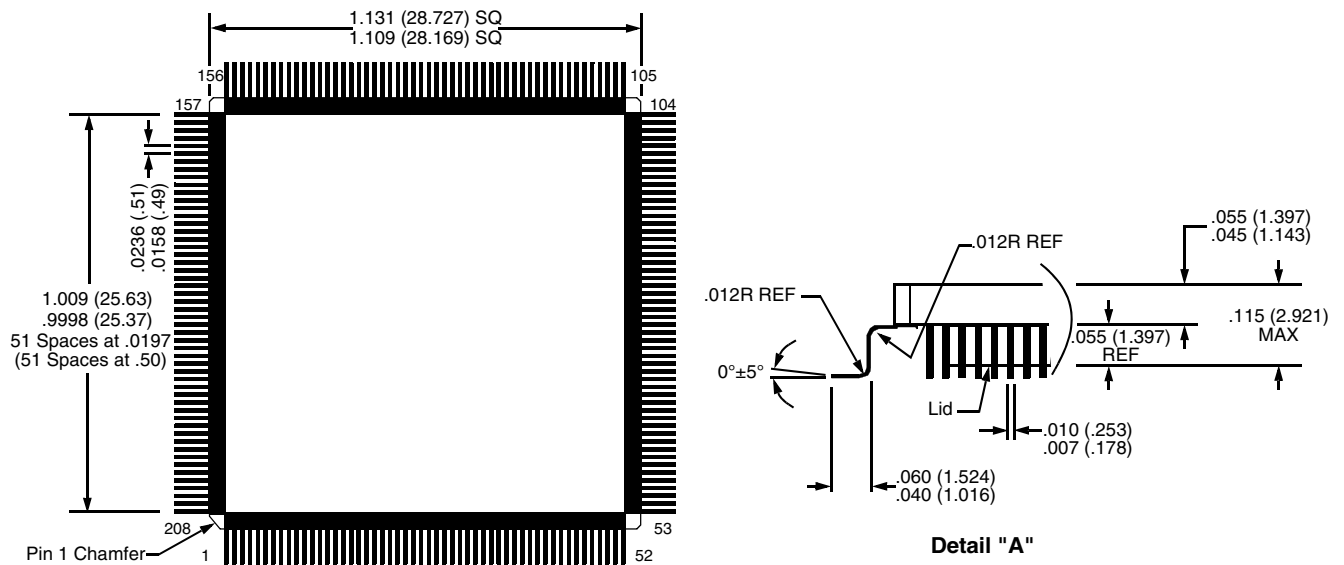

**Detail "A"**

Units: Inches (Millimeters)

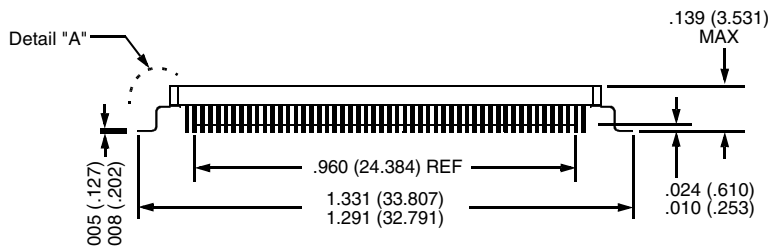

Note: Pin rotation is identical to QEDs PQUAD due to cavity-down construction.



## ACT 7000SC Microprocessor CQFP Pinouts – "F17" & "F24"

Pin #	Function	Pin #	Function	Pin #	Function	Pin #	Function
1	VccIO	53	NC	105	VccIO	157	NC
2	NC	54	NC	106	NMI*	158	NC
3	NC	55	NC	107	ExtRqst*	159	NC
4	VccIO	56	VccIO	108	Reset*	160	NC
5	Vss	57	Vss	109	ColdReset*	161	VccIO
6	SysAD4	58	Modeln	110	VccOK	162	Vss
7	SysAD36	59	RdRdy*	111	BigEndian	163	SysAD28
8	SysAD5	60	WrRdy*	112	VccIO	164	SysAD60
9	SysAD37	61	ValidIn*	113	Vss	165	SysAD29
10	Vcclnt	62	ValidOut*	114	SysAD16	166	SysAD61
11	Vss	63	Release*	115	SysAD48	167	Vcclnt
12	SysAD6	64	VccP	116	Vcclnt	168	Vss
13	SysAD38	65	VssP	117	Vss	169	SysAD30
14	VccIO	66	SysClock	118	SysAD17	170	SysAD62
15	Vss	67	Vcclnt	119	SysAD49	171	VccIO
16	SysAD7	68	Vss	120	SysAD18	172	Vss
17	SysAD39	69	VccIO	121	SysAD50	173	SysAD31
18	SysAD8	70	Vss	122	VccIO	174	SysAD63
19	SysAD40	71	Vcclnt	123	Vss	175	SysADC2
20	Vcclnt	72	Vss	124	SysAD19	176	SysADC6
21	Vss	73	SysCmd0	125	SysAD51	177	Vcclnt
22	SysAD9	74	SysCmd1	126	Vcclnt	178	Vss
23	SysAD41	75	SysCmd2	127	Vss	179	SysADC3
24	VccIO	76	SysCmd3	128	SysAD20	180	SysADC7
25	Vss	77	VccIO	129	SysAD52	181	VccIO
26	SysAD10	78	Vss	130	SysAD21	182	Vss
27	SysAD42	79	SysCmd4	131	SysAD53	183	SysADC0
28	SysAD11	80	SysCmd5	132	VccIO	184	SysADC4
29	SysAD43	81	VccIO	133	Vss	185	Vcclnt
30	Vcclnt	82	Vss	134	SysAD22	186	Vss
31	Vss	83	SysCmd6	135	SysAD54	187	SysADC1
32	SysAD12	84	SysCmd7	136	Vcclnt	188	SysADC5
33	SysAD44	85	SysCmd8	137	Vss	189	SysAD0
34	VccIO	86	SysCmdP	138	SysAD23	190	SysAD32
35	Vss	87	Vcclnt	139	SysAD55	191	VccIO
36	SysAD13	88	Vss	140	SysAD24	192	Vss
37	SysAD45	89	Vcclnt	141	SysAD56	193	SysAD1
38	SysAD14	90	Vss	142	VccIO	194	SysAD33
39	SysAD46	91	VccIO	143	Vss	195	Vcclnt
40	Vcclnt	92	Vss	144	SysAD25	196	Vss
41	Vss	93	Int0*	145	SysAD57	197	SysAD2
42	SysAD15	94	Int1*	146	Vcclnt	198	SysAD34
43	SysAD47	95	Int2*	147	Vss	199	SysAD3
44	VccIO	96	Int3*	148	SysAD26	200	SysAD35
45	Vss	97	Int4*	149	SysAD58	201	VccIO
46	ModeClock	98	Int5*	150	SysAD27	202	Vss
47	JTDO	99	VccIO	151	SysAD59	203	NC
48	JTDI	100	Vss	152	VccIO	204	NC
49	JTCK	101	NC	153	Vss	205	NC
50	JTMS	102	NC	154	NC	206	NC
51	VccIO	103	NC	155	NC	207	VccIO
52	Vss	104	NC	156	Vss	208	Vss

## Sample Ordering Information

Part Number	Screening	Speed (MHz)	Package
ACT-7000SC-150F17I	Industrial Temperature	150	208 Lead CQFP
ACT-7000SC-200F17C	Commercial Temperature	200	
ACT-7000SC-210F17T	Military Temperature	210	
ACT-7000SC-225F17M	Military Screening	225	

## Part Number Breakdown

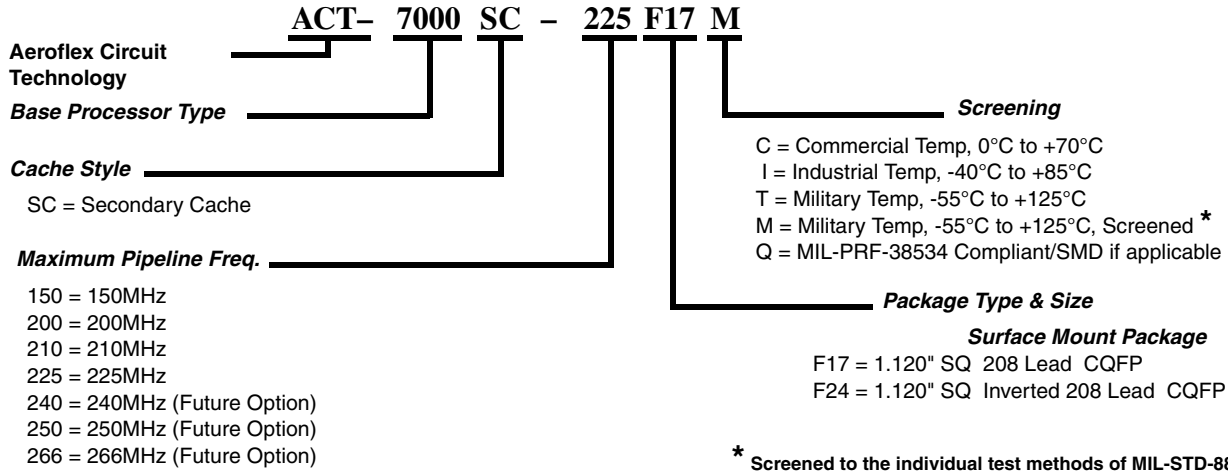

The QED logo and RISCMark are trademarks of PMC-Sierra, Inc.  
 MIPS is a registered trademark of MIPS Technologies, Inc. All other trademarks are the respective property of the trademark holders.

<p><b>EXPORT CONTROL:</b>                  This product is controlled for export under the International Traffic in Arms Regulations (ITAR). A license from the U.S. Department of State is required prior to the export of this product from the United States.</p>	<p><b>EXPORT WARNING:</b>                  Aeroflex's military and space products are controlled for export under the International Traffic in Arms Regulations (ITAR) and may not be sold or proposed or offered for sale to certain countries. (See ITAR 126.1 for complete information.)</p>
--	---

<p><b>PLAINVIEW, NEW YORK</b>                  Toll Free: 800-THE-1553                  Fax: 516-694-6715</p>	<p><b>INTERNATIONAL</b>                  Tel: 805-778-9229                  Fax: 805-778-1980</p>	<p><b>NORTHEAST</b>                  Tel: 603-888-3975                  Fax: 603-888-4585</p>
<p><b>SE AND MID-ATLANTIC</b>                  Tel: 321-951-4164                  Fax: 321-951-4254</p>	<p><b>WEST COAST</b>                  Tel: 949-362-2260                  Fax: 949-362-2266</p>	<p><b>CENTRAL</b>                  Tel: 719-594-8017                  Fax: 719-594-8468</p>

**www.aeroflex.com info-ams@aeroflex.com**

Aeroflex Microelectronic Solutions reserves the right to change at any time without notice the specifications, design, function, or form of its products described herein. All parameters must be validated for each customer's application by engineering. No liability is assumed as a result of use of this product. No patent licenses are implied. All trademarks are acknowledged. Parent company Aeroflex, Inc. 2003.







Our passion for performance is defined by three attributes represented by these three icons: solution-minded, performance-driven and customer-focused

## X-ON Electronics

Largest Supplier of Electrical and Electronic Components

*Click to view similar products for [aeroflex](#) manufacturer:*

Other Similar products are found below :

[69A-30-11](#) [1444-2](#) [57-40-33](#) [980-2](#) [40-3-34](#) [M1406A](#) [3M-6](#) [3M-40](#) [4H-3](#) [ACT4404N-201](#) [1N4744A](#) [18A-05](#) [18A-04](#) [23A-03](#) [5085](#) [18A-06](#) [JANTX1N6642U](#) [18B10W-06](#) [1N5313-1JANTX](#) [18A-30](#) [PPT1250-400-50R0J](#) [JANS1N6638US](#) [JANTXV2N6301](#) [6AH-15](#) [JANTXV2N3715](#) [JANTX1N4150-1](#) [6AH-10](#) [18A-10](#) [6AH-30](#) [JANTX2N2222AUB](#) [18AH-20](#) [40AH-03](#) [JANTX1N5524B-1](#) [JAN1N752AUR-1](#) [JANTXV1N827-1](#) [A3WH09-5R](#) [PCA-3](#) [PCAF-10](#) [JANTXV1N6638U](#) [18AH-00](#) [18AH-04](#) [18AH-08](#) [PPA20-5](#) [JANTX2N3715](#) [JANTXV1N4106UR-1](#) [18AH-09](#) [PCAF-16](#) [PCAF-3](#) [40AH-10](#) [18AH-07](#)