

# AT73HL Series

40V, 250mA, Low Quiescent Current, CMOS LDO

## Description

The AT73HL series is a high accuracy, high input voltage low quiescent current, high speed, and low dropout linear regulator with high ripple rejection.

The input voltage up to 40V and load current up to 250mA at  $V_{OUT} = 5V$  &  $V_{IN} = 15V$ . The device is manufactured with CMOS process. The AT73HL offers over-current limit and over temperature protection to ensure the device working in well conditions.

The AT73HL regulators are available in standard SOT89-3L and SOT23-5L、SOT23-3L packages. Standard products are Pb-free and Halogen-free.

## Features

- Input voltage: 4.75V~40V
- Output voltage: 1.8V~5.7V
- Output accuracy:  $< \pm 2\%$
- Output current: 250mA @  $V_{IN} = 12V$ ,  $V_{OUT} = 5V$
- PSRR: 60dB @ 100Hz
- Dropout voltage: 600mV @  $I_{OUT} = 100mA$
- Quiescent current: 5 $\mu$ A @  $V_{IN} = 12V$ (Typ.)
- Recommend capacitor: 10 $\mu$ F

## Applications

- Smart electric meter
- In-car entertainment
- Electric bicycle

## Pin Assignment

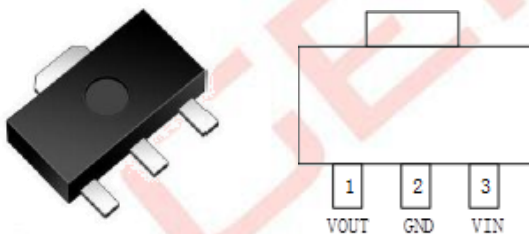

AT73HL XX SQ(SOT89-3L)

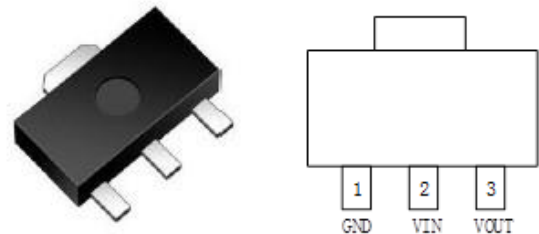

AT73HL XX SQB(SOT89-3L)

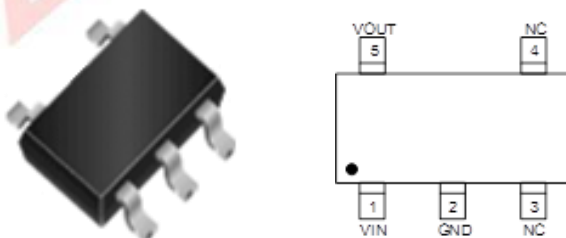

AT73HL XX SE(SOT23-5L)

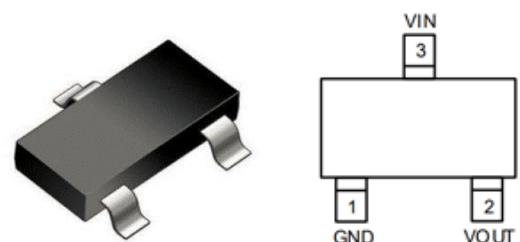

AT73HL XX SC(SOT-23-3L)

## Simplified Block Diagram

### Typical Application

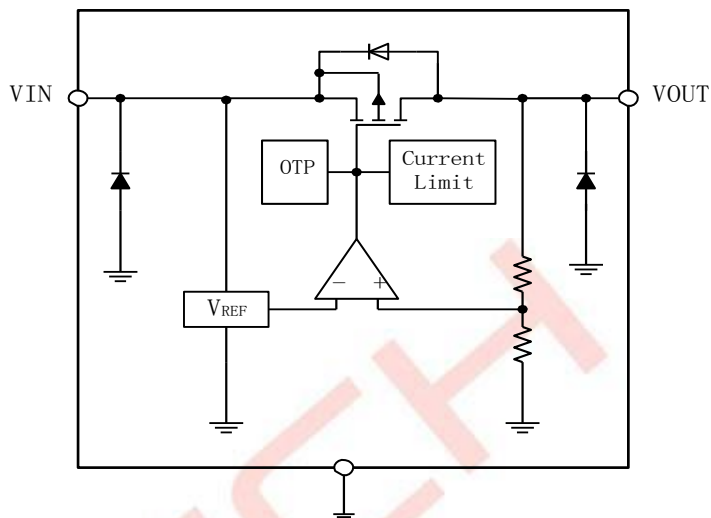
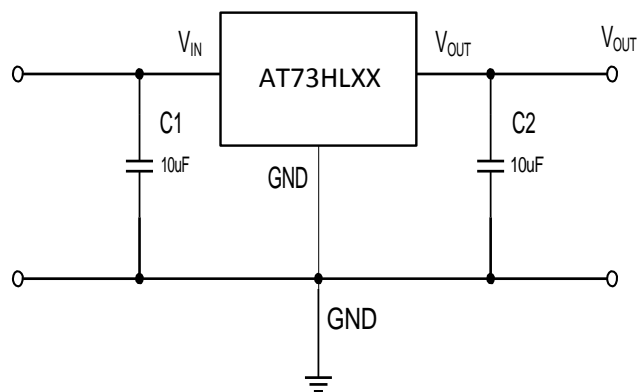

### Order Information

Part No	Package	Temperature	Tape & Reel
AT73HL XX SQ	SOT89-3L	-40 ~ +85 °C	1000/REEL
AT73HL XX SQB	SOT89-3L	-40 ~ +85 °C	1000/REEL
AT73HL XX SE	SOT23-5L	-40 ~ +85 °C	3000/REEL
AT73HL XX SC	SOT23-3L	-40 ~ +85 °C	3000/REEL

Note: \*\* several fixed output voltages ranging from 1.8V to 5.7V

### Part number rules

AT73HL①②③

Designator	Description
①	Output Voltage 3.3V=33 5.0V=50
②	Package: SE: SOT-23-5L SQ: SOT89-3L SC: SOT23-3L
③	Different Pin Definition B:

### Pin Description

Pin No			Symbol	I/O	Description
SOT89-3L(B)	SOT89-3L	SOT23-5L			
3	2	1	VIN	Power	Input
2	1	2	GND	Ground	Ground
-	-	3	NC	-	Not connected
-	-	4	NC	-	Not connected
1	3	5	VOUT	O	Output

## Absolute Maximum Ratings(Note)

Symbol	Items	Value	Unit	
$V_{IN}$	Input Voltage	-0.3~45	V	
$V_{OUT}$	Output Voltage	-0.3~6.5	V	
$P_{DMAX}$	Power Dissipation	SOT89-3L	0.7	W
		SOT23-5L	0.3	W
		SOT23-3L	0.25	W
$T_J$	Junction Temperature	-40~150	°C	
$T_{stg}$	Storage Temperature	-55 to 150	°C	
$T_{solder}$	Package Lead Soldering Temperature (10s)	260	°C	
ESD MM	Machine Mode	200	V	
ESD HBM	Human Body Mode	8000	V	

**Note:** Exceed these limits to damage to the device. Exposure to absolute maximum rating conditions may affect device reliability.

## Recommended Operating Range

Symbol	Items	Value	Unit
$V_{IN}$	$V_{IN}$ Supply Voltage	4.75 to 40	V
$R_{\theta JA}$	Thermal Resistance on PCB	45	°C/W
$T_{OPT}$	Operating Temperature	-40 to +85	°C

**Electrical Characteristics**(The following specifications apply for  $V_{IN} = 12V$ ,  $T_A = 25^\circ C$ ,  $C_{IN} = C_{OUT} = 10\mu F$ , unless specified otherwise)

Symbol	Items	Conditions	Min.	Typ.	Max.	Unit
$V_{IN}$	Input Range	$I_{OUT} = 10mA$	4.75		40	V
$V_{OUT}$	Output Range	$I_{OUT} = 10mA$	-2	$V_{OUT}$	2	%
$I_{OUT}$	Maximum Output Current	$V_{IN}-V_{OUT}=4V, R_L=1\Omega$		500	550	mA
$\Delta V_{OUT}$	Output Voltage	$V_{IN} = 12V, I_{OUT} = 10mA$	4.9	5	5.1	V
			3.234	3.3	3.366	
			2.94	3.0	3.06	
			2.45	2.5	2.55	
$I_Q$	Quiescent Current	$V_{IN} = 7V, I_{OUT} = 0$		4	6	$\mu A$
		$V_{IN} = 24V, I_{OUT} = 0$		4.6	6.7	
		$V_{IN} = 40V, I_{OUT} = 0$		5.4	8.2	
$I_{OTP}$	Current at OTP	$V_{IN} = 12V, V_{OUT} = 1.5V$		130		mA
$V_{DROP}$	Dropout Voltage	$I_{OUT} = 10mA$		60		mV
		$I_{OUT} = 100mA$		600		
$\Delta V_{LINE}$	Line Regulation	$V_{IN}=7 \sim 24V, V_{OUT} = 5V, I_{OUT} = 1mA$		0.001		%V
		$V_{IN} = 7 \sim 40V, V_{OUT} = 5V, I_{OUT} = 1mA$		0.002		
$\Delta V_{LOAD}$	Load Regulation	$V_{OUT} = 5V, I_{OUT} = 1 \sim 100mA, V_{IN} = 7V$		19		mV
$I_{SHORT}$	Short Current	$V_{OUT}$ Short to GND with 1Ω(1ms pulse), $V_{IN} = 40V$		280		mA
PSRR	Power Supply Rejection Ratio	$V_{IN} = 10V, V_{PP} = 0.5V, I_{OUT} = 1mA$	$F = 100Hz$	60		dB
			$F = 1kHz$	50		
			$F = 10kHz$	40		
$e_{NO}$	Output Noise Voltage	10Hz to 100kHz, $C_{OUT} = 10\mu F$		±100		$\mu V_{RMS}$
$T_{SD}$	Thermal Shutdown	$V_{IN} = 12V, I_{OUT} = 1mA$		150		°C
$\Delta V_O/\Delta T$	Temperature Coefficient			±0.5		mV/°C

**Typical Performance Characteristics**( $C_{IN} = 10\mu F$ ,  $C_{OUT} = 10\mu F$ ,  $TOPT = 25^{\circ}C$ ,  $V_{IN} = 6V$ ,  $V_{OUT} = 5V$ , unless specified otherwise)

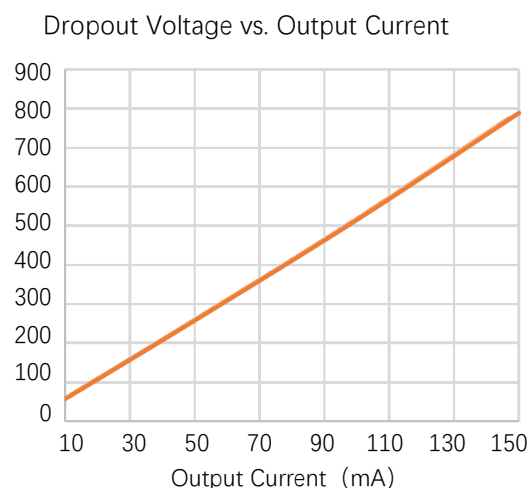
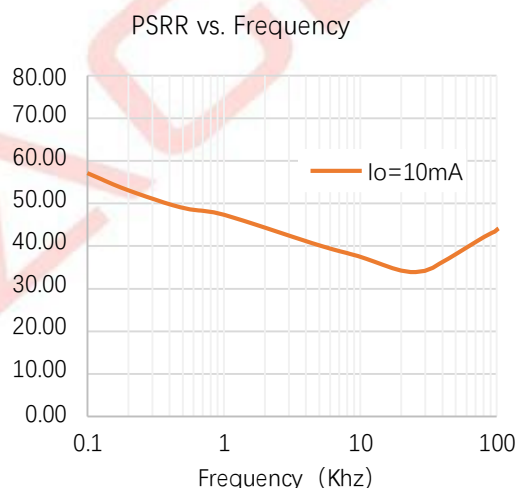
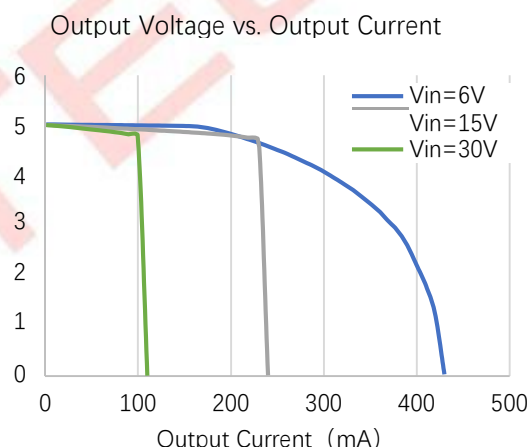
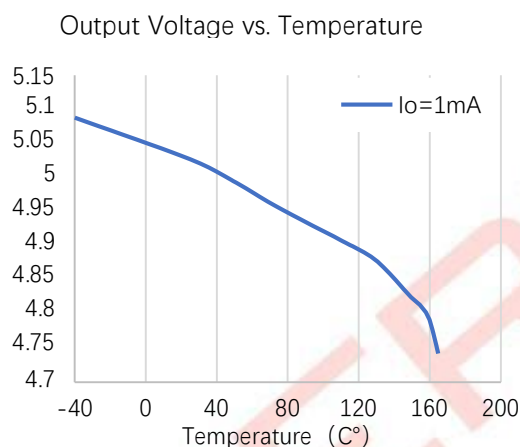
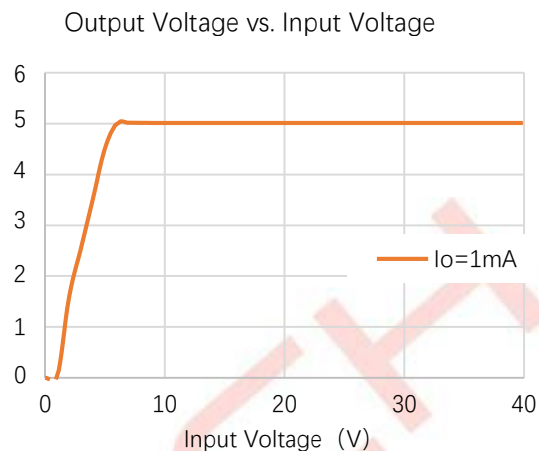
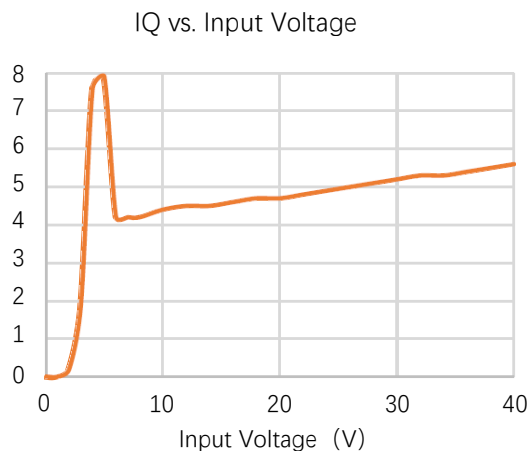

## Power ON

CH1 :  $V_{IN}$  CH2 :  $V_{OUT}$  CH4 :  $I_{IN}$

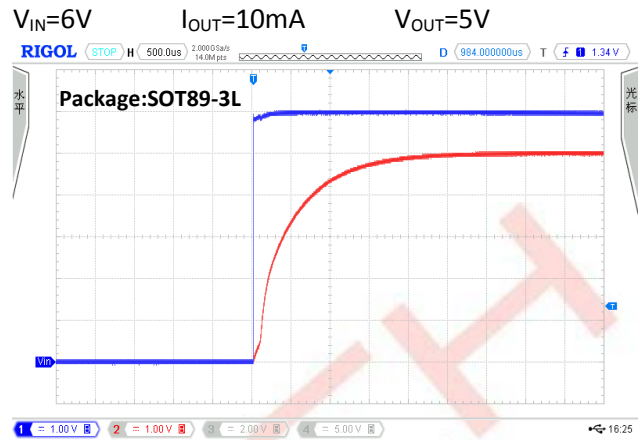
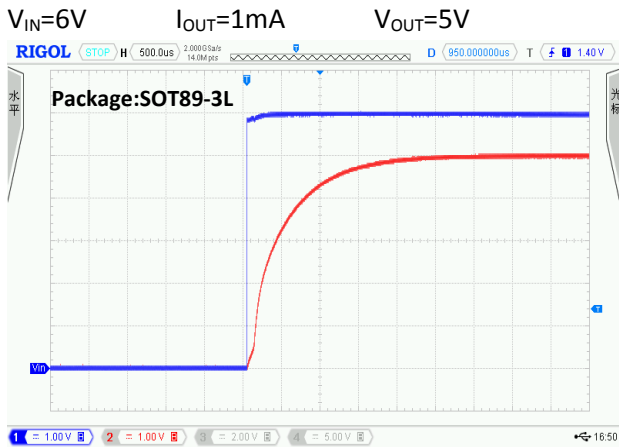

## Line Transient

CH1 :  $V_{IN}$  CH2 :  $V_{OUT}$

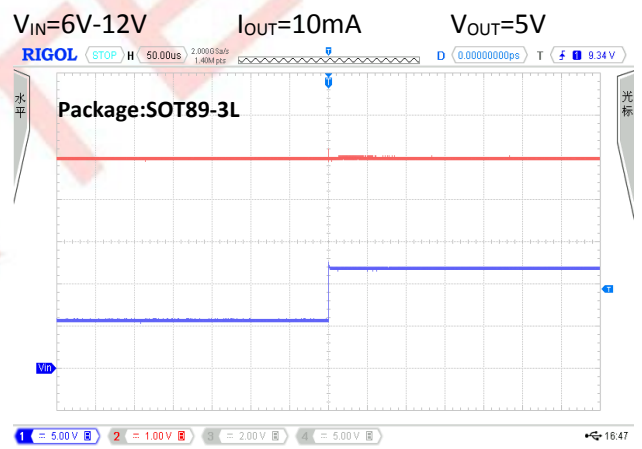
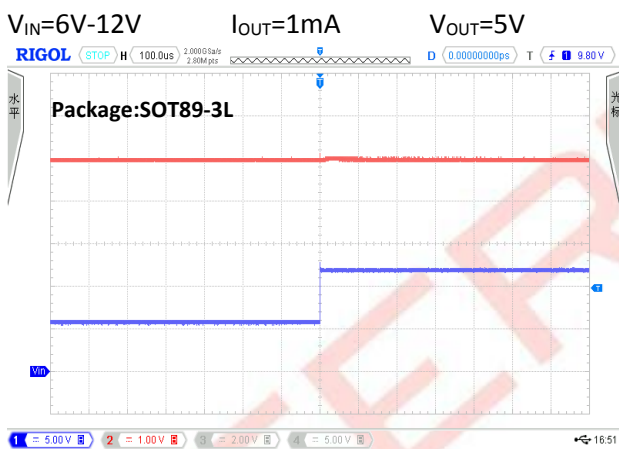

## Load Transient

CH1 :  $V_{IN}$  CH2 :  $V_{OUT}$  CH4 :  $I_{OUT}$

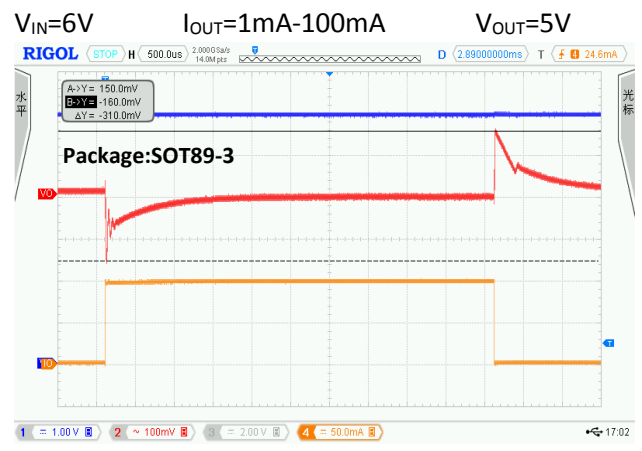
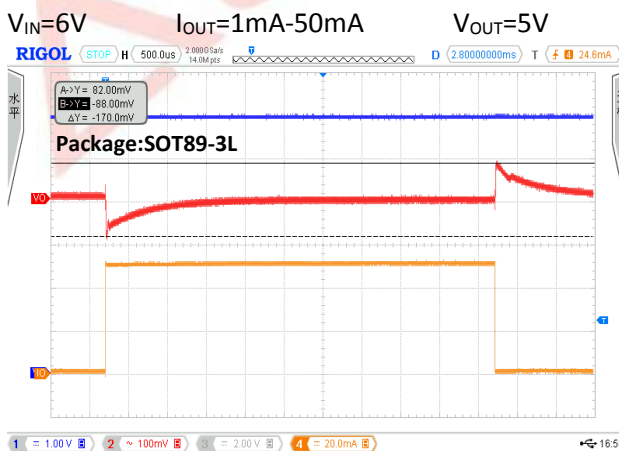

## SOT23-5L Package Outline

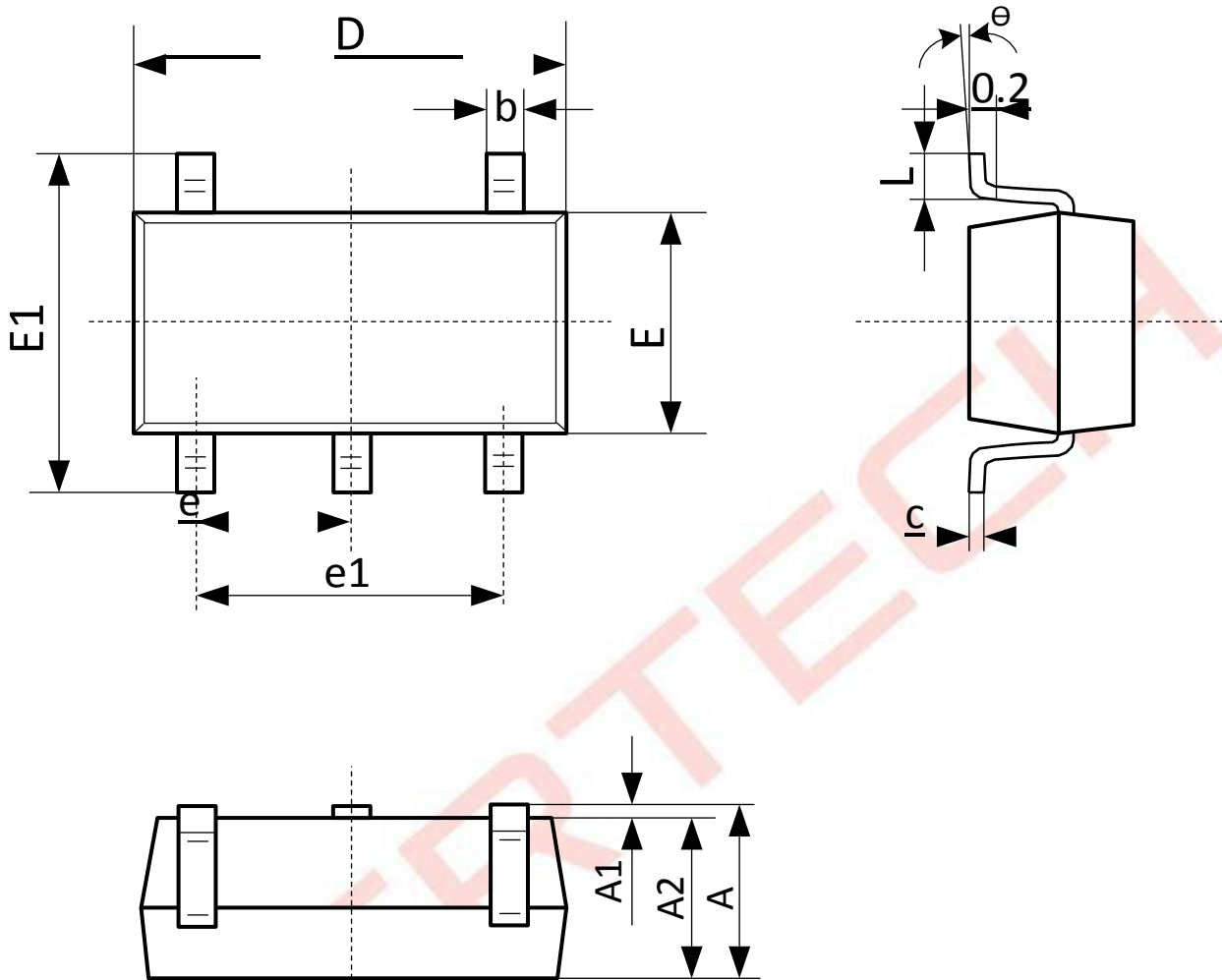

Symbol	Dimensions In Millimeters		Dimensions In Inches	
	Min	Max	Min	Max
A	1.050	1.250	0.041	0.049
A1	0.000	0.100	0.000	0.004
A2	1.050	1.150	0.041	0.045
b	0.300	0.500	0.012	0.020
c	0.100	0.200	0.004	0.008
D	2.820	3.020	0.111	0.119
E	1.500	1.700	0.059	0.067
E1	2.650	2.950	0.104	0.116
e	0.950(BSC)		0.037(BSC)	
e1	1.800	2.000	0.071	0.079
L	0.300	0.600	0.012	0.024
$\theta$	0°C	8°C	0°C	8°C

## SOT89-3L Package Outline

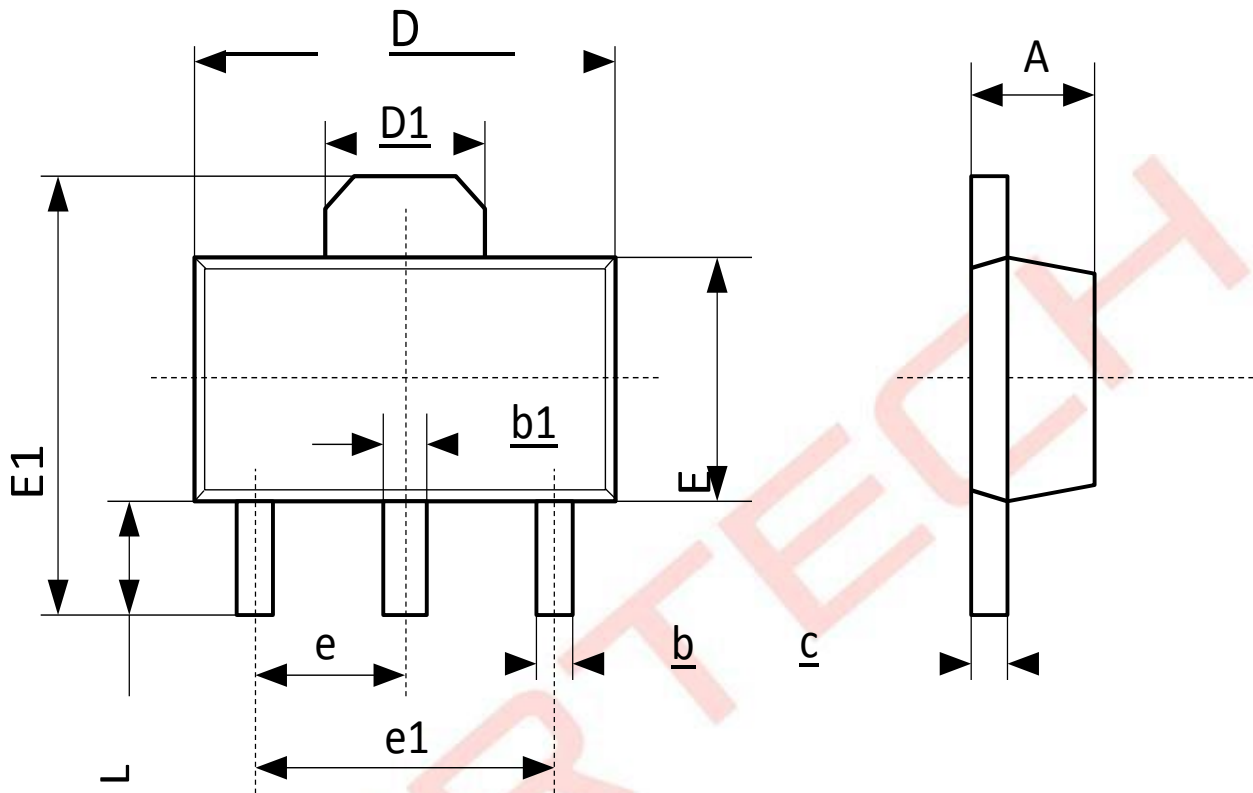

Symbol	Dimensions In Millimeters		Dimensions In Inches	
	Min	Max	Min	Max
A	1.400	1.600	0.055	0.063
b	0.320	0.520	0.013	0.020
b1	0.400	0.580	0.016	0.023
c	0.350	0.440	0.014	0.017
D	4.400	4.600	0.173	0.181
D1	1.550 REF		0.061 REF	
E	2.300	2.600	0.091	0.102
E1	3.940	4.250	0.155	0.167
e	1.500 TYP		0.060 TYP	
e1	3.000 TYP		0.118 TYP	
L	0.900	1.200	0.035	0.047



## SOT-23-3L Package Outline

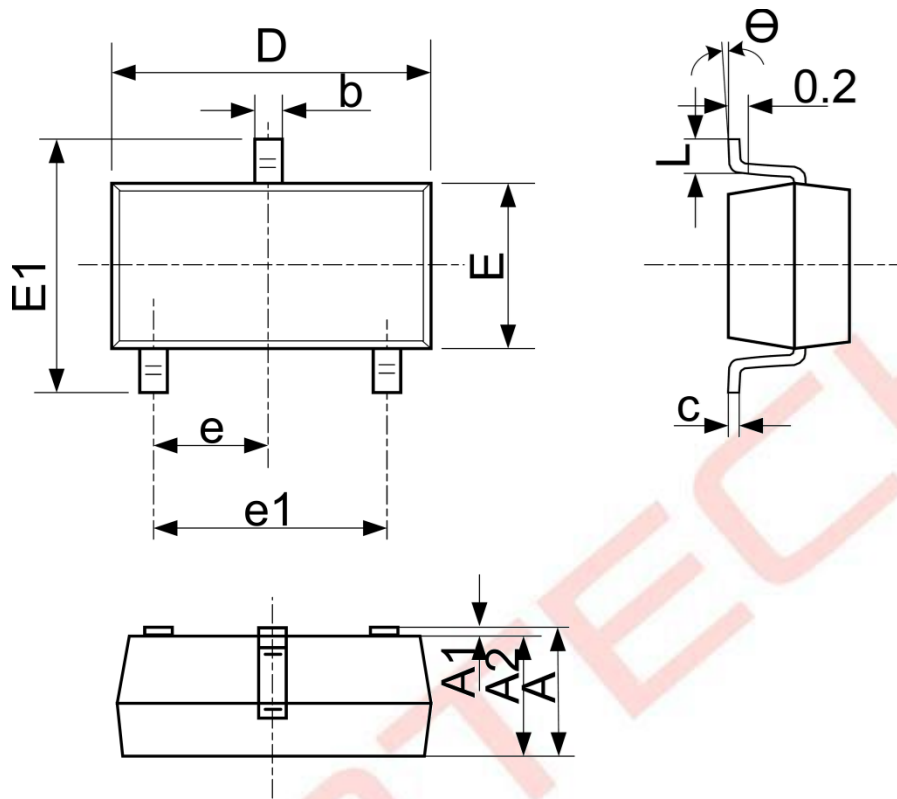

Symbol	Dimensions In Millimeters		Dimensions In Inches	
	Min	Max	Min	Max
A	1.050	1.250	0.041	0.049
A1	0.000	0.100	0.000	0.004
A2	1.050	1.150	0.041	0.045
b	0.300	0.500	0.012	0.020
c	0.100	0.200	0.004	0.008
D	2.820	3.020	0.111	0.119
E	1.500	1.700	0.059	0.067
E1	2.650	2.950	0.104	0.116
e	0.950(BSC)		0.037(BSC)	
e1	1.800	2.000	0.071	0.079
L	0.300	0.600	0.012	0.024
θ	0°C	8°C	0°C	8°C



## X-ON Electronics

Largest Supplier of Electrical and Electronic Components

*Click to view similar products for [Linear Voltage Regulators](#) category:*

*Click to view products by [Agertech](#) manufacturer:*

Other Similar products are found below :

[LV56831P-E](#) [LV5684PVD-XH](#) [MCDTSA6-2R](#) [L7815ACV-DG](#) [PQ3DZ53U](#) [LV56801P-E](#) [TLE42794G](#) [L78L05CZ/1SX](#) [L78LR05DL-MA-E](#) [636416C](#) [714954EB](#) [BA033LBSG2-TR](#) [LV5680P-E](#) [L78M15CV-DG](#) [TLS202B1MBV33HTSA1](#) [L79M05T-E](#) [TLS202A1MBVHTSA1](#) [L78LR05D-MA-E](#) [NCV317MBTG](#) [NTE7227](#) [LV5680NPVC-XH](#) [LT1054CN8](#) [MP2018GZD-5-Z](#) [MP2018GZD-33-Z](#) [MIC5281-3.3YMM](#) [MC78L06BP-AP](#) [TA48LS05F\(TE85L,F\)](#) [TA78L12F\(TE12L,F\)](#) [TC47BR5003ECT](#) [TCR2LN12,LF\(S](#) [TCR2LN28,LF\(S](#) [TCR2LN30,LF\(S](#) [TCR3DF295,LM\(CT](#) [TCR3DF40,LM\(CT](#) [BA178M20CP-E2](#) [L78M12ABDT](#) [LM7812SX/NOPB](#) [LR645N3-G-P003](#) [LR645N3-G-P013](#) [ZXTR2005P5-13](#) [SCD7812BTG](#) [TCR3DF335,LM\(CT](#) [ZXTR2012K-13](#) [TLE42994E V33](#) [ZXTR2008K-13](#) [ZXTR2005K-13](#) [L88R05DL-E](#) [ADP3300ARTZ-2.7RL7](#) [LM120K-15/883](#) [IFX54441LDVXUMA1](#)