

AT75ALXX Series

Low Dropout Regulator AT75ALXX

Input Voltage: up to 36V Output: 2.8V~5.0V

DESCRIPTION

The AT75ALXX series is a set of three-terminal low power high voltage regulators implemented in CMOS technology. They allow input voltages as high as 36V. They are available with several fixed output voltages ranging from 2.8V to 5.0V. Because of the low power dissipation, AT75ALXXSQ/SC are widely used in a variety of equipment such as audio device, video device, communication device and so on.

FEATURES

- ◆ Low power consumption
- ◆ Low voltage drop
- ◆ Low temperature coefficient
- ◆ High input voltage (up to 36V)
- ◆ Quiescent current : 2.5 μ A
- ◆ Output voltage tolerance: \pm 3%
- ◆ RoHS compliant

APPLICATIONS

- ◆ Battery-powered equipment
- ◆ Communication equipment
- ◆ Audio/Video equipment

SELECTION TABLE

Designator	Symbol	Description
AT75ALXXSC/SQ	28	2.8V(output)
	30	3.0V
	33	3.3V
	36	3.6V
	40	4.0V
	44	4.4V
	50	5.0V

OUTLINE and PINNING

SOT-23-3L

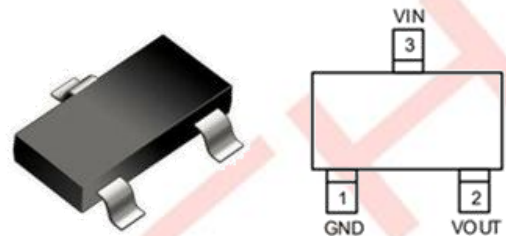

AT75AL XX SC

SOT-89

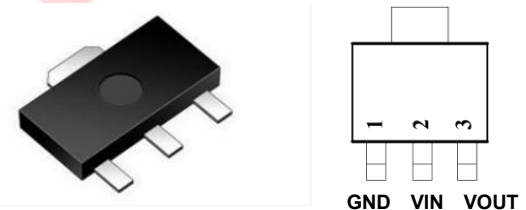

AT75AL XX SQ



AT75ALXX Series

ABSOLUTE MAXIMUM RATINGS^(NOTE1)

Ratings at 25°C ambient temperature unless otherwise specified.

Parameter	Limit	Unit
Supply voltage	-0.3 ~ +36	V
Storage temperature range	-50 ~ +125	°C
Operating temperature range	-40 ~ +85	°C

NOTE: 1. Stresses beyond those listed under absolute maximum ratings may cause permanent damage to the device. These are stress ratings only, and functional operation of the device at these or any other conditions beyond those conditions is not implied. Exposure to absolute-maximum-rated conditions for extended periods may affect device reliability.

Parameter	Symbol	Value	Unit
Junction-to-Ambient Thermal Resistance	R _{θJA}	200	°C/W
Power Consumption (SOT-89)	P _D	500	mW
Power Consumption (SOT-23-3L)	P _D	250	mW
Human body model	HBM	3	KV
Charged device model	CDM	200	V

ELECTRICAL CHARACTERISTICS

AT75AL28SQ/SC (T_A=25°C)

Parameter	Symbol	Test conditions	Min.	Typ.	Max	Unit
Output voltage	V _{OUT}	V _{IN} =V _{OUT} +2.0V, I _{OUT} =10mA	2.716	2.80	2.884	V
Output current	I _{OUT}	V _{IN} =V _{OUT} +2.0V	70	100	—	mA
Load regulation	ΔV _{OUT}	V _{IN} =V _{OUT} +2.0V 1mA ≤ I _{OUT} ≤ 50mA	—	25	60	mV
Voltage drop ^{Note1}	V _{DIF}	I _{OUT} =1mA, ΔV _{OUT} =2%	—	30	100	mV
Quiescent Current	I _{SS}	No Load	—	2.5	3.0	μA
Line regulation	$\frac{\Delta V_{OUT}}{V_{OUT}} \times \frac{\Delta V_{IN}}{V_{IN}}$	V _{OUT} +1.0V ≤ V _{IN} ≤ 30V, I _{OUT} =1mA	—	—	0.2	%/V
Input voltage	V _{IN}	—	—	—	36	V
Temperature coefficient	$\frac{\Delta V_{OUT}}{V_{OUT}} \times \Delta T_A$	V _{IN} =V _{OUT} +2.0V, I _{OUT} =10mA, -40°C ≤ T _A ≤ 85°C	—	100	—	ppm/°C

AT75ALXX Series



AT75AL30SQ/SC(T_A=25°C)

Parameter	Symbol	Test conditions	Min.	Typ.	Max	Unit
Output voltage	V _{OUT}	V _{IN} =V _{OUT} +2.0V , I _{OUT} =10mA	2.910	3.00	3.090	V
Output current	I _{OUT}	V _{IN} =V _{OUT} +2.0V	70	100	—	mA
Load regulation	ΔV _{OUT}	V _{IN} =V _{OUT} +2.0V 1mA≤I _{OUT} ≤50mA	—	25	60	mV
Voltage drop ^{Note1}	V _{DIF}	I _{OUT} =1mA , ΔV _{OUT} =2%	—	30	100	mV
Quiescent Current	I _{SS}	No Load	—	2.5	3.0	μA
Line regulation	ΔV _{OUT} / V _{OUT} ×ΔV _{IN}	V _{OUT} +1.0V≤V _{IN} ≤30V , I _{OUT} =1mA	—	—	0.2	%/V
Input voltage	V _{IN}	—	—	—	36	V
Temperature coefficient	ΔV _{OUT} / V _{OUT} ×ΔT _A	V _{IN} =V _{OUT} +2.0V, I _{OUT} =10mA , -40°C≤T _A ≤85°C	—	100	—	ppm/°C

AT75AL33SQ/SC(T_A=25°C)

Parameter	Symbol	Test conditions	Min.	Typ.	Max	Unit
Output voltage	V _{OUT}	V _{IN} =V _{OUT} +2.0V , I _{OUT} =10mA	3.201	3.30	3.399	V
Output current	I _{OUT}	V _{IN} =V _{OUT} +2.0V	70	100	—	mA
Load regulation	ΔV _{OUT}	V _{IN} =V _{OUT} +2.0V 1mA≤I _{OUT} ≤50mA	—	25	60	mV
Voltage drop ^{Note1}	V _{DIF}	I _{OUT} =1mA , ΔV _{OUT} =2%	—	25	55	mV
Quiescent Current	I _{SS}	No Load	—	2.5	3.0	μA
Line regulation	ΔV _{OUT} / V _{OUT} ×ΔV _{IN}	V _{OUT} +1.0V≤V _{IN} ≤30V , I _{OUT} =1mA	—	—	0.2	%/V
Input voltage	V _{IN}	—	—	—	36	V
Temperature coefficient	ΔV _{OUT} / V _{OUT} ×ΔT _A	V _{IN} =V _{OUT} +2.0V, I _{OUT} =10mA , -40°C≤T _A ≤85°C	—	100	—	ppm/°C

AT75AL36SQ/SC(T_A=25°C)

Parameter	Symbol	Test conditions	Min.	Typ.	Max	Unit
Output voltage	V _{OUT}	V _{IN} =V _{OUT} +2.0V , I _{OUT} =10mA	3.492	3.60	3.708	V
Output current	I _{OUT}	V _{IN} =V _{OUT} +2.0V	70	100	—	mA
Load regulation	ΔV _{OUT}	V _{IN} =V _{OUT} +2.0V 1mA≤I _{OUT} ≤50mA	—	25	60	mV
Voltage drop ^{Note1}	V _{DIF}	I _{OUT} =1mA , ΔV _{OUT} =2%	—	25	55	mV
Quiescent Current	I _{SS}	No Load	—	2.5	3.0	μA
Line regulation	ΔV _{OUT} / V _{OUT} ×ΔV _{IN}	V _{OUT} +1.0V≤V _{IN} ≤30V , I _{OUT} =1mA	—	—	0.2	%/V
Input voltage	V _{IN}	—	—	—	36	V
Temperature coefficient	ΔV _{OUT} / V _{OUT} ×ΔT _A	V _{IN} = V _{OUT} +2.0V, I _{OUT} =10mA , -40°C≤T _A ≤85°C	—	100	—	ppm/°C



AT75ALXX Series

AT75AL40SQ/SC(T_A=25°C)

Parameter	Symbol	Test conditions	Min.	Typ.	Max	Unit
Output voltage	V _{OUT}	V _{IN} =V _{OUT} +2.0V , I _{OUT} =10mA	3.880	4.0	4.120	V
Output current	I _{OUT}	V _{IN} =V _{OUT} +2.0V	70	100	—	mA
Load regulation	ΔV _{OUT}	V _{IN} =V _{OUT} +2.0V 1mA≤I _{OUT} ≤50mA	—	25	60	mV
Voltage drop ^{Note1}	V _{DIF}	I _{OUT} =1mA , ΔV _{OUT} =2%	—	25	55	mV
Quiescent Current	I _{SS}	No Load	—	2.5	3.0	μA
Line regulation	ΔV _{OUT} / V _{OUT} × ΔV _I	V _{OUT} +1.0V≤V _{IN} ≤30V , I _{OUT} =1mA	—	—	0.2	%/V
Input voltage	V _{IN}	—	—	—	36	V
Temperature coefficient	ΔV _{OUT} / V _{OUT} × ΔT _A	V _{IN} = V _{OUT} +2.0V, I _{OUT} =10mA , -40°C≤T _A ≤85°C	—	100	—	ppm/°C

AT75AL44SQ/SC(T_A=25°C)

Parameter	Symbol	Test conditions	Min.	Typ.	Max	Unit
Output voltage	V _{OUT}	V _{IN} =V _{OUT} +2.0V , I _{OUT} =10mA	4.268	4.4	4.532	V
Output current	I _{OUT}	V _{IN} =V _{OUT} +2.0V	70	100	—	mA
Load regulation	ΔV _{OUT}	V _{IN} =V _{OUT} +2.0V 1mA≤I _{OUT} ≤50mA	—	25	60	mV
Voltage drop ^{Note1}	V _{DIF}	I _{OUT} =1mA , ΔV _{OUT} =2%	—	25	55	mV
Quiescent Current	I _{SS}	No Load	—	2.5	3.0	μA
Line regulation	ΔV _{OUT} / V _{OUT} × ΔV _{IN}	V _{OUT} +1.0V≤V _{IN} ≤30V , I _{OUT} =1mA	—	—	0.2	%/V
Input voltage	V _{IN}	—	—	—	36	V
Temperature coefficient	ΔV _{OUT} / V _{OUT} × ΔT _A	V _{IN} = V _{OUT} +2.0V, I _{OUT} =10mA , -40°C≤T _A ≤85°C	—	100	—	ppm/°C

AT75AL50SQ/SC(T_A=25°C)

Parameter	Symbol	Test conditions	Min.	Typ.	Max	Unit
Output voltage	V _{OUT}	V _{IN} =V _{OUT} +2.0V , I _{OUT} =10mA	4.850	5.0	5.150	V
Output current	I _{OUT}	V _{IN} =V _{OUT} +2.0V	100	150	—	mA
Load regulation	ΔV _{OUT}	V _{IN} =V _{OUT} +2.0V 1mA≤I _{OUT} ≤70mA	—	25	60	mV
Voltage drop ^{Note1}	V _{DIF}	I _{OUT} =1mA , ΔV _{OUT} =2%	—	25	55	mV
Quiescent Current	I _{SS}	No Load	—	3.5	4.0	μA
Line regulation	ΔV _{OUT} / V _{OUT} × ΔV _{IN}	V _{OUT} +1.0 V≤V _{IN} ≤30V , I _{OUT} =1mA	—	—	0.2	%/V
Input voltage	V _{IN}	—	—	—	36	V
Temperature coefficient	ΔV _{OUT} / V _{OUT} × ΔT _A	V _{IN} = V _{OUT} +2.0V, I _{OUT} =10mA , -40°C≤T _A ≤85°C	—	100	—	ppm/°C

NOTE: 1. The difference of input voltage and output voltage when input voltage falls down gradually till output voltage equals to 98% of rating V_{OUT}.

APPLICATION CIRCUIT

Basic circuits

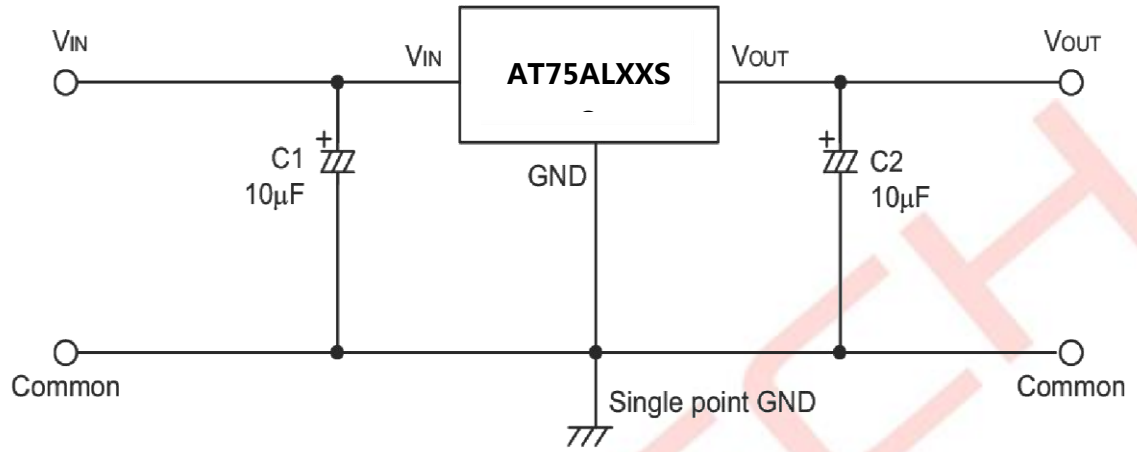

PACKAGE OUTLINE

SOT-23-3L

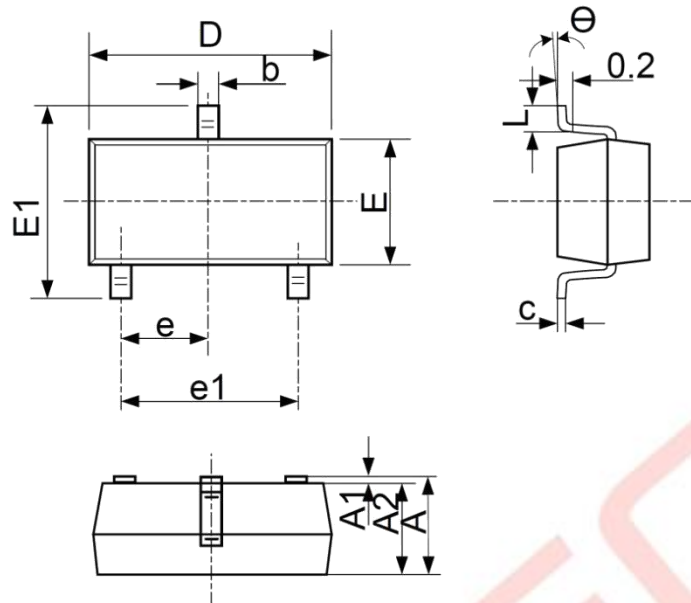

Symbol	Dimensions In Millimeters		Dimensions In Inches	
	Min	Max	Min	Max
A	1.050	1.250	0.041	0.049
A1	0.000	0.100	0.000	0.004
A2	1.050	1.150	0.041	0.045
b	0.300	0.500	0.012	0.020
c	0.100	0.200	0.004	0.008
D	2.820	3.020	0.111	0.119
E	1.500	1.700	0.059	0.067
E1	2.650	2.950	0.104	0.116
e	0.950(BSC)		0.037(BSC)	
e1	1.800	2.000	0.071	0.079
L	0.300	0.600	0.012	0.024
θ	0°C	8°C	0°C	8°C

PACKAGE OUTLINE

SOT- 89

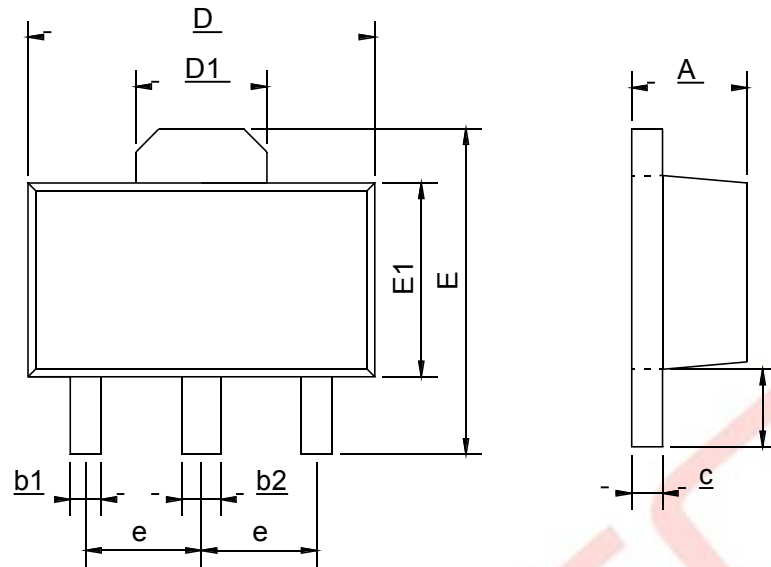

Symbol	Dimensions In Millimeters		Dimensions In Inches	
	Min	Max	Min	Max
A	1.40	1.60	0.055	0.063
b1	0.38	0.47	0.015	0.019
b2	0.46	0.56	0.018	0.022
c	0.36	0.46	0.014	0.018
D	4.30	4.70	0.169	0.185
D1	1.50	1.90	0.059	0.075
E	4.00	4.40	0.157	0.173
E1	2.30	2.70	0.091	0.106
e	1.45	1.55	0.057	0.061
L	0.80	1.20	0.031	0.047

CONDITIONS OF SOLDERING

◆ Recommended condition of reflow soldering

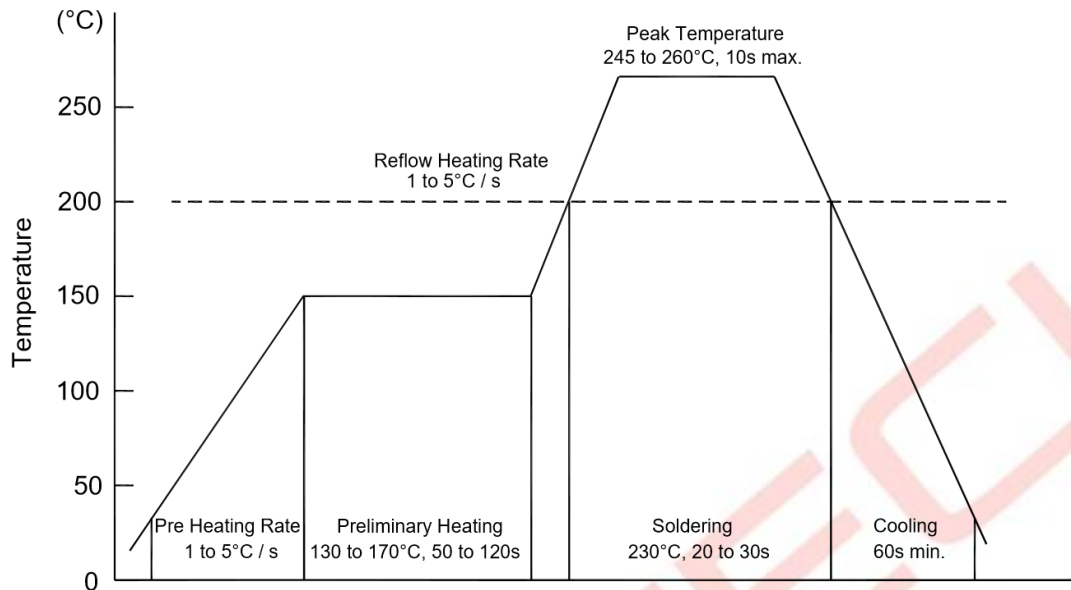

Recommended peak temperature is over 245 °C. If peak temperature is below 245 °C, you may adjust the following parameters:

- Time length of peak temperature (longer)
- Time length of soldering (longer)
- Thickness of solder paste (thicker)

◆ Conditions of hand soldering

- Temperature: 370 °C
- Time: 3s max.
- Times: one time

◆ Storage conditions

- **Temperature**
5 to 40 °C
- **Humidity**
30 to 80% RH
- **Recommended period**
One year after manufacturing

PACKAGING SPECIFICATION

The method of packaging and dimension are shown as below figure.

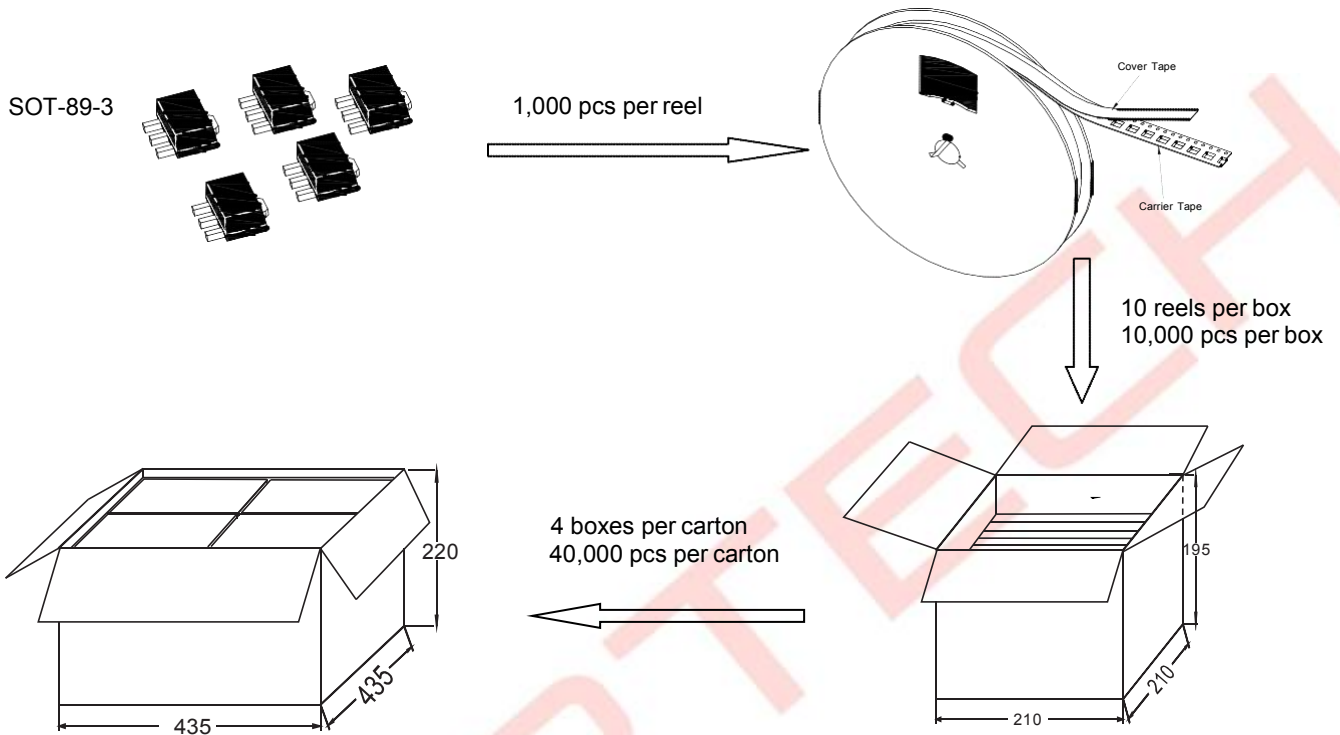

Tape and reel data (Units: mm)

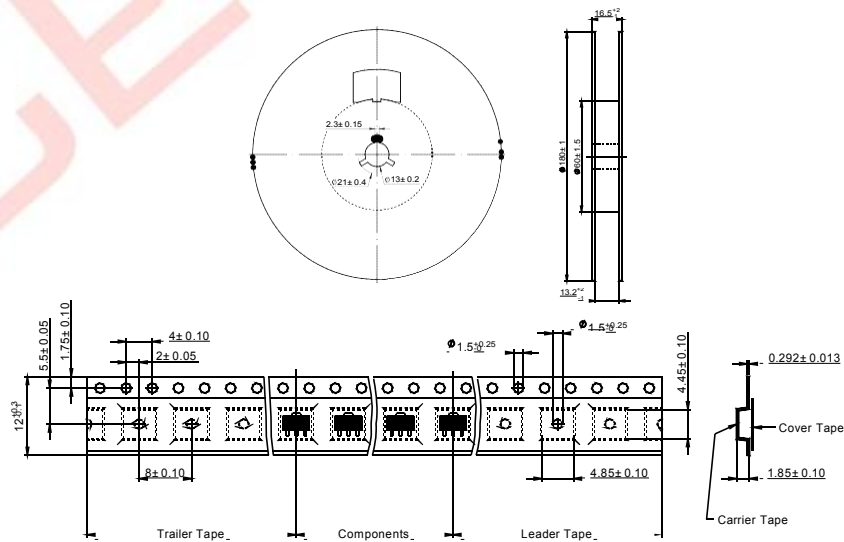

X-ON Electronics

Largest Supplier of Electrical and Electronic Components

Click to view similar products for [Linear Voltage Regulators](#) category:

Click to view products by [Agertech](#) manufacturer:

Other Similar products are found below :

[LV5684PVD-XH](#) [MCDTSA6-2R](#) [L7815ACV-DG](#) [LV56801P-E](#) [UA7805CKC](#) [714954EB](#) [ZMR500QFTA](#) [BA033LBSG2-TR](#)
[NCV78M05ABDTRKG](#) [LV5680P-E](#) [L79M05T-E](#) [L78LR05D-MA-E](#) [NCV317MBTG](#) [NTE7227](#) [MP2018GZD-33-P](#) [MP2018GZD-5-P](#)
[LV5680NPVC-XH](#) [ZTS6538SE](#) [UA78L09CLP](#) [UA78L09CLPR](#) [CAT6221-PPTD-GT3](#) [MC78M09CDTRK](#) [NCV51190MNTAG](#)
[BL1118CS8TR1833](#) [BL8563CKETR18](#) [BL8077CKETR33](#) [BL9153-33CC3TR](#) [BL9161G-15BADRN](#) [BL9161G-28BADRN](#)
[BRCO7530MMC](#) [CJ7815B-TFN-ARG](#) [LM317C](#) [GM7333K](#) [GM7350K](#) [XC6206P332MR](#) [HT7533](#) [LM7912S/TR](#) [LT1764S/TR](#) [LM7805T](#)
[LM338T](#) [LM1117IMP-3.3/TR](#) [HT1117AM-3.3](#) [HT7550S](#) [AMS1117-3.3](#) [HT7150S](#) [78L12](#) [HT7550](#) [HT7533-1](#) [HXY6206I-2.5](#) [HT7133](#)