

SS22B-AT thru SS220B-AT

SURFACE MOUNT SCHOTTKY BARRIER RECTIFIERS

Forward Current: 2A

Reverse Voltage: 20V to 200V

FEATURES

- ◆ For surface mount applications
- ◆ High forward surge current capability
- ◆ Low power loss, high efficiency
- ◆ Metal silicon junction, majority carriers conduction

PINNING

PIN	DESCRIPTION
1	Cathode
2	Anode

MECHANICAL DATA

- ◆ Case: SMB molded plastic body
- ◆ Terminals: Solderable per MIL-STD-750 , Method 2026
- ◆ Weight: Approximated 0.055 grams

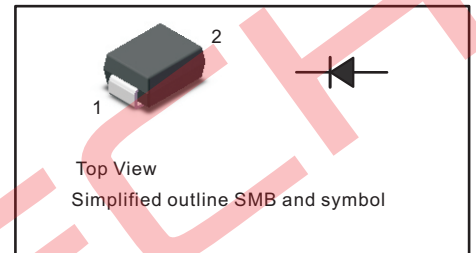

MAXIMUM RATINGS AND ELECTRICAL CHARACTERISTICS

Ratings at 25°C ambient temperature unless otherwise specified.
Single phase half-wave 60 Hz, resistive or inductive load, for capacitive load current derating by 20 %.

PARAMETER	SYMBOL	SS22B -AT	SS24B -AT	SS26B -AT	SS28B -AT	SS210B -AT	SS212B -AT	SS215B -AT	SS220B -AT	UNIT
Maximum Repetitive Peak Reverse Voltage	V_{RRM}	20	40	60	80	100	120	150	200	V
Maximum RMS voltage	V_{RMS}	14	28	42	56	70	84	105	140	V
Maximum DC Blocking Voltage	V_{DC}	20	40	60	80	100	120	150	200	V
Maximum Average Forward Rectified Current	$I_{F(AV)}$	2.0								A
Peak Forward Surge Current ^(Note1)	I_{FSM}	55				45				A
Max Instantaneous Forward Voltage at 2 A	V_F	0.55		0.70		0.85		0.95		V
Maximum DC Reverse Current at Rated DC Blocking Voltage $T_a = 25^\circ\text{C}$ $T_a = 100^\circ\text{C}$	I_R	0.5 5			0.3 3				mA	
Typical Junction Capacitance ^(Note2)	C_J	220			110				pF	
Typical Thermal Resistance ^(Note3)	$R_{\theta JA}$	75								$^\circ\text{C}/\text{W}$
Operating Junction Temperature Range	T_J	-55 ~ +125								$^\circ\text{C}$
Storage Temperature Range	T_{STG}	-55 ~ +150								$^\circ\text{C}$

Notes: 1. Measured at 8.3 ms single half sine wave superimposed on rated load (JEDEC Method).
2. Measured at 1MHz and applied reverse voltage of 4 V D.C.
3. P.C.B. mounted with 2.0" X 2.0" (5cm X 5 cm) copper pad areas.

SS22B-AT thru SS220B-AT

RATINGS AND CHARACTERISTIC CURVES

Fig.1 Forward Current Derating Curve

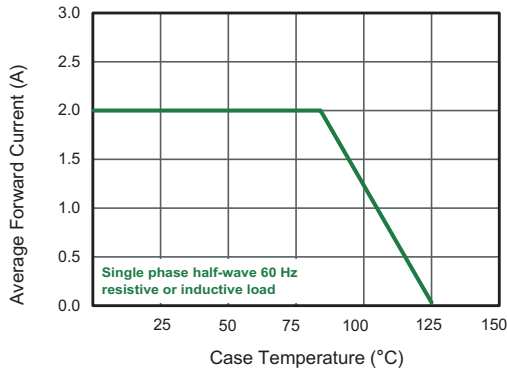

Fig.2 Typical Reverse Characteristics

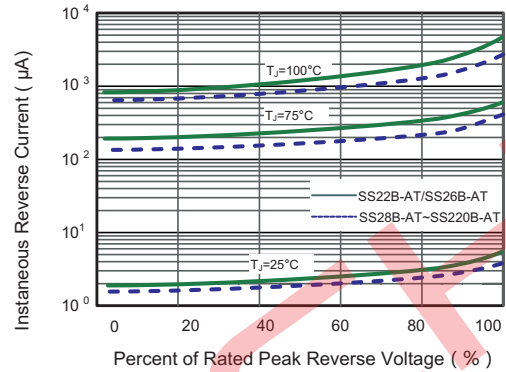

Fig.3 Typical Forward Characteristic

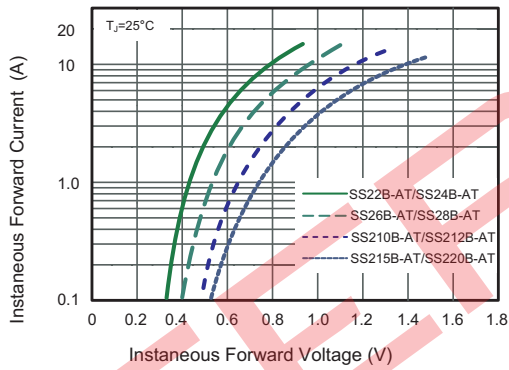

Fig.4 Typical Junction Capacitance

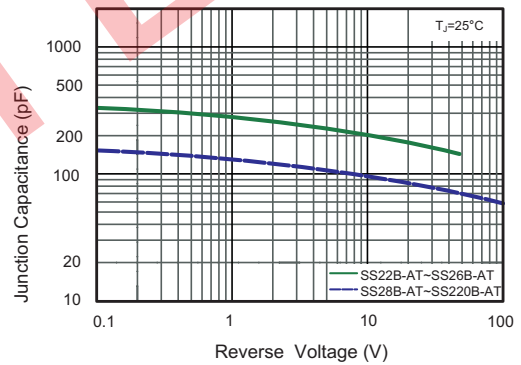

Fig.5 Maximum Non-Repetitive Peak Forward Surge Current

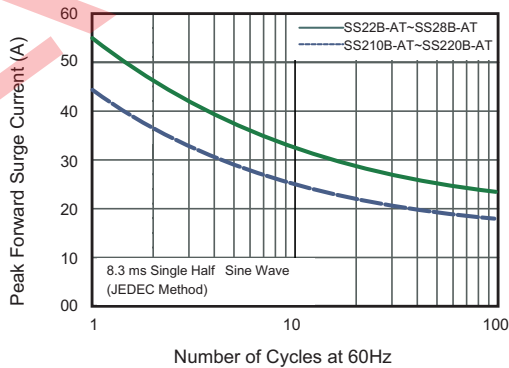
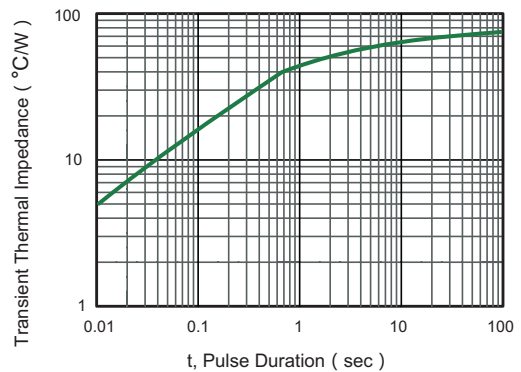

Fig.6- Typical Transient Thermal Impedance



SS22B-AT thru SS220B-AT

PACKAGE OUTLINE

SMB

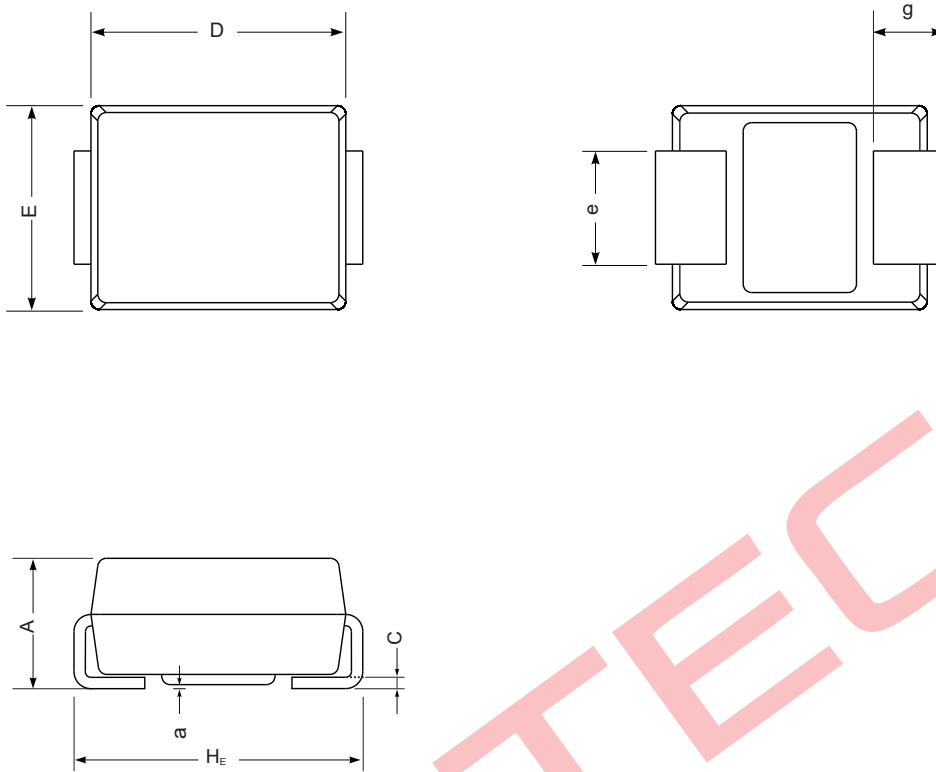

UNIT		A	D	E	H _E	C	e	g	a
mm	max	2.44	4.70	3.94	5.59	0.305	2.2	1.5	0.2
	min	2.13	4.06	3.3	5.08	0.152	1.9	0.8	0.05

The recommended mounting pad size

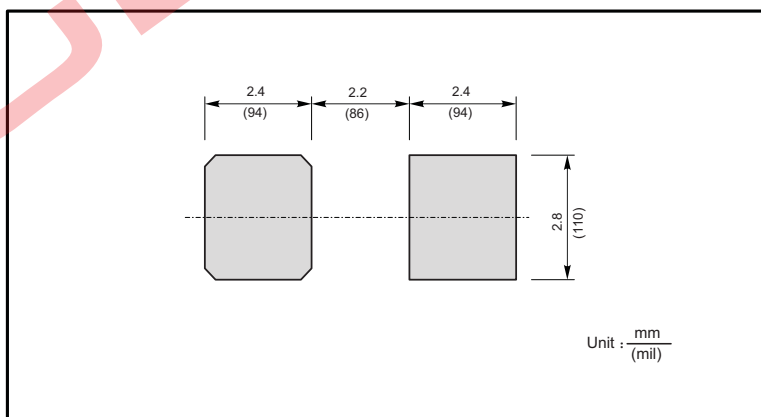

ORDER INFORMATION

Device	Package	Shipping
SS22B-AT thru SS220B-AT	SMB	3000PCS/Reel&Tape(13inch)

X-ON Electronics

Largest Supplier of Electrical and Electronic Components

Click to view similar products for [Schottky Diodes & Rectifiers](#) category:

Click to view products by [Agertech](#) manufacturer:

Other Similar products are found below :

[MA4E2039](#) [MA4E2508M-1112](#) [MBR0530L-TP](#) [MBR10100CT-BP](#) [MBR1545CT](#) [MMBD301M3T5G](#) [RB160M-50TR](#)
[BAS16E6433HTMA1](#) [BAS 3010S-02LRH E6327](#) [BAT 54-02LRH E6327](#) [IDL02G65C5XUMA1](#) [NSR05F40QNXT5G](#) [NSVR05F40NXT5G](#)
[NTE555](#) [JANS1N6640](#) [SB07-03C-TB-H](#) [SB1003M3-TL-W](#) [SBM30-03-TR-E](#) [SBS818-TL-E](#) [SK310-T](#) [SK33A-TP](#) [SK34B-TP](#) [SS3003CH-](#)
[TL-E](#) [PDS3100Q-7](#) [GA01SHT18](#) [CRS10I30A\(TE85L,QM](#) [MA4E2501L-1290](#) [MBRA140TRPBF](#) [MBRB30H30CT-1G](#) [JANTX1N5712-1](#)
[SB007-03C-TB-E](#) [SK33B-TP](#) [SK35A-TP](#) [SK38B-LTP](#) [NTE505](#) [NTSB30U100CT-1G](#) [VS-6CWQ10FNHM3](#) [CRG04\(T5L,TEMQ\)](#)
[ACDBA1100LR-HF](#) [ACDBA1200-HF](#) [ACDBA240-HF](#) [ACDBA3100-HF](#) [CDBQC0530L-HF](#) [ACDBA260LR-HF](#) [ACDBA1100-HF](#)
[MA4E2502L-1246](#) [10BQ015-M3/5BT](#) [10BQ060-M3/5BT](#) [NRVB130LSFT1G](#) [CRS08TE85LQM](#)