

- ★ 100% EAS Guaranteed
- ★ Green Device Available
- ★ Super Low Gate Charge
- ★ Excellent CdV/dt effect decline
- ★ Advanced high cell density Trench technology

**Product Summary**

BVDSS	RDSON	ID
30V	5.8mΩ	46A

**PRPAK3.3X3.3 Pin Configuration**

**Description**

AGM306AP is the high cell density trenched N-ch MOSFETs, which provide excellent RDSON and gate charge for most of the synchronous buck converter applications.

**Package Marking and Ordering Information**

Device Marking	Device	Device Package	Reel Size	Tape width	Quantity
AGM306AP	AGM306AP	DFN3.3*3.3	---mm	---mm	5000

**Table 1. Absolute Maximum Ratings (TA=25°C)**

Symbol	Parameter	Value	Unit
V <sub>DS</sub>	Drain-Source Voltage (V <sub>GS</sub> =0V)	30	V
V <sub>GS</sub>	Gate-Source Voltage (V <sub>DS</sub> =0V)	±20	V
I <sub>D</sub>	Drain Current-Continuous(T <sub>c</sub> =25°C) (Note 1)	46	A
	Drain Current-Continuous(T <sub>c</sub> =100°C)	29	A
I <sub>DM (pulse)</sub>	Drain Current-Continuous@ Current-Pulsed (Note 2)	92	A
P <sub>D</sub>	Maximum Power Dissipation(T <sub>c</sub> =25°C)	45	W
	Maximum Power Dissipation(T <sub>c</sub> =100°C)	29	W
E <sub>AS</sub>	Avalanche energy (Note 3)	67	mJ
T <sub>J</sub> , T <sub>STG</sub>	Operating Junction and Storage Temperature Range	-55 To 150	°C

**Table 2. Thermal Characteristic**

Symbol	Parameter	Typ	Max	Unit
R <sub>θJA</sub>	Thermal Resistance Junction-ambient (Steady State) <sup>1</sup>	---	63	°C/W
R <sub>θJC</sub>	Thermal Resistance Junction-Case <sup>1</sup>	---	6.2	°C/W

**Table 3. Electrical Characteristics (TA=25°C unless otherwise noted)**

Symbol	Parameter	Conditions	Min	Typ	Max	Unit
<b>On/Off States</b>						
BV <sub>DSS</sub>	Drain-Source Breakdown Voltage	V <sub>GS</sub> =0V, I <sub>D</sub> =250μA	30			V
I <sub>DSS</sub>	Zero Gate Voltage Drain Current	V <sub>DS</sub> =30V, V <sub>GS</sub> =0V			1	μA
I <sub>GSS</sub>	Gate-Body Leakage Current	V <sub>GS</sub> =±20V, V <sub>DS</sub> =0V			±100	nA
V <sub>GS(th)</sub>	Gate Threshold Voltage	V <sub>DS</sub> =V <sub>GS</sub> , I <sub>D</sub> =250μA	1.2	1.4	2.2	V
g <sub>FS</sub>	Forward Transconductance	V <sub>DS</sub> =5V, I <sub>D</sub> =20A		10		S
R <sub>DS(ON)</sub>	Drain-Source On-State Resistance	V <sub>GS</sub> =10V, I <sub>D</sub> =20A		5.7	8.5	mΩ
		V <sub>GS</sub> =4.5V, I <sub>D</sub> =15A		9.5	13	mΩ
<b>Dynamic Characteristics</b>						
C <sub>iss</sub>	Input Capacitance	V <sub>DS</sub> =15V, V <sub>GS</sub> =0V, F=1MHZ		1070		pF
C <sub>oss</sub>	Output Capacitance			163		pF
Cr <sub>ss</sub>	Reverse Transfer Capacitance			110		pF
R <sub>g</sub>	Gate resistance	V <sub>GS</sub> =0V, V <sub>DS</sub> =0V, f=1.0MHz		1.7		Ω
<b>Switching Times</b>						
t <sub>d(on)</sub>	Turn-on Delay Time	V <sub>GS</sub> =10V, V <sub>DS</sub> =12V, R <sub>L</sub> =0.75Ω, R <sub>GEN</sub> =3.3Ω		4.5		nS
t <sub>r</sub>	Turn-on Rise Time			10.8		nS
t <sub>d(off)</sub>	Turn-Off Delay Time			22.5		nS
t <sub>f</sub>	Turn-Off Fall Time			9.6		nS
Q <sub>g</sub>	Total Gate Charge	V <sub>GS</sub> =4.5V, V <sub>DS</sub> =20V, I <sub>D</sub> =12A		12.8		nC
Q <sub>gs</sub>	Gate-Source Charge			3.3		nC
Q <sub>gd</sub>	Gate-Drain Charge			6.5		nC
<b>Source-Drain Diode Characteristics</b>						
I <sub>S</sub>	Continuous Source Current	V <sub>G</sub> =V <sub>D</sub> =0V, Force Current			46	A
V <sub>SD</sub>	Forward on Voltage	V <sub>GS</sub> =0V, I <sub>S</sub> =20A			1.0	V

Notes 1.The maximum current rating is package limited.

Notes 2.Repetitive Rating: Pulse width limited by maximum junction temperature

Notes 3.EAS condition: T<sub>J</sub>=25°C, V<sub>DD</sub>=15V, V<sub>G</sub>=10V, R<sub>G</sub>=25Ω

**Typical Characteristics**

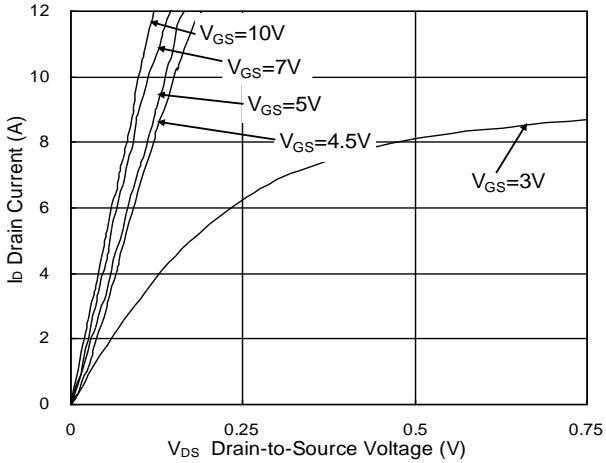

**Fig.1 Typical Output Characteristics**

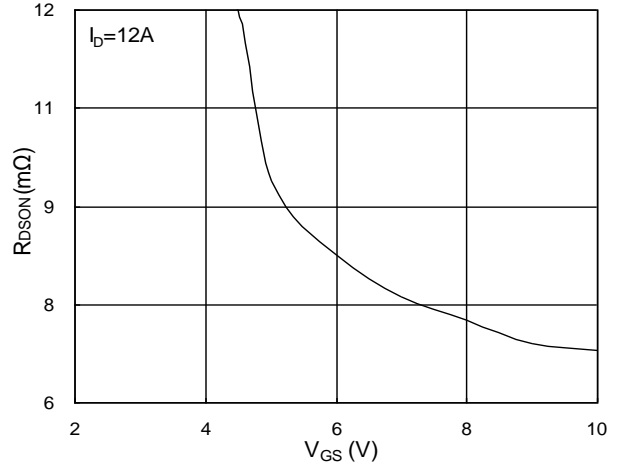

**Fig.2 On-Resistance vs. Gate-Source**

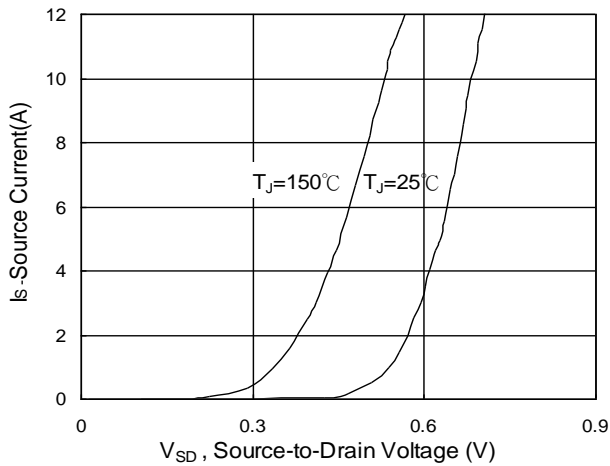

**Fig.3 Forward Characteristics Of Reverse**

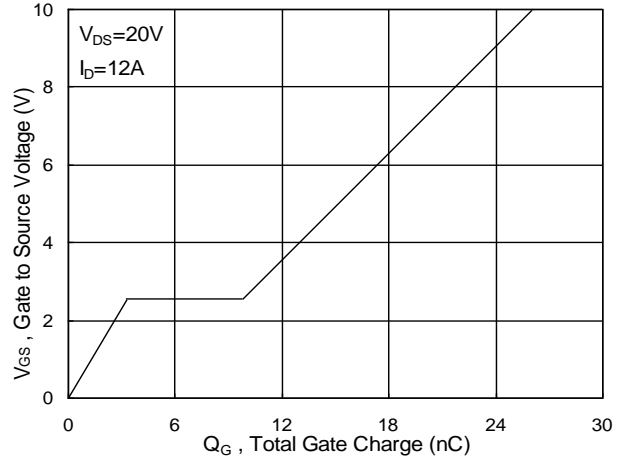

**Fig.4 Gate-Charge Characteristics**

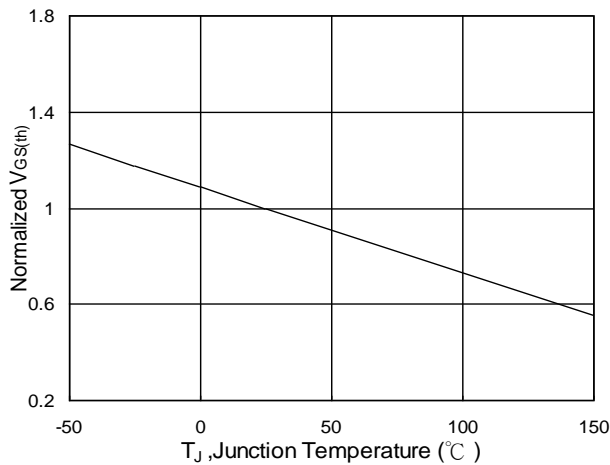

**Fig.5 Normalized V<sub>GS(th)</sub> vs. T<sub>J</sub>**

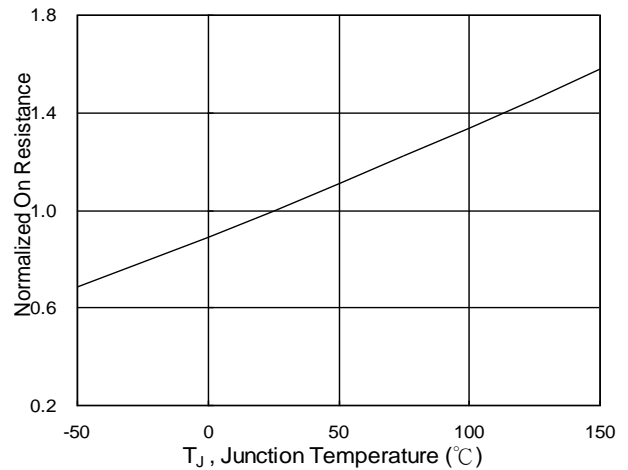

**Fig.6 Normalized R<sub>DSON</sub> vs. T<sub>J</sub>**

Data and specifications subject to change without notice.

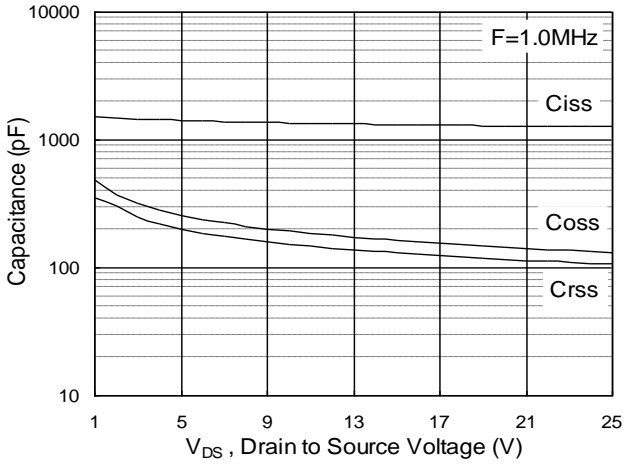

Fig.7 Capacitance

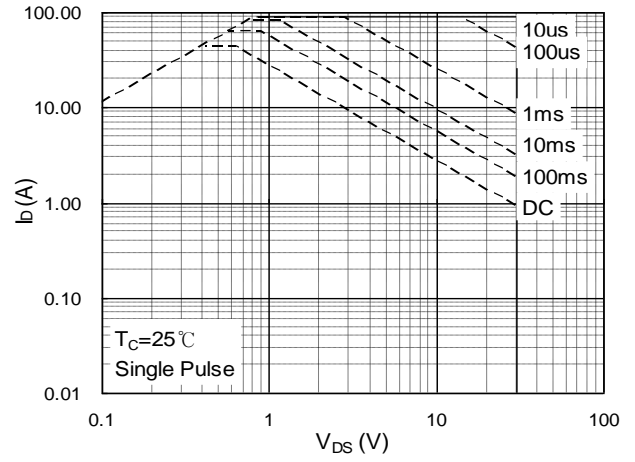

Fig.8 Safe Operating Area

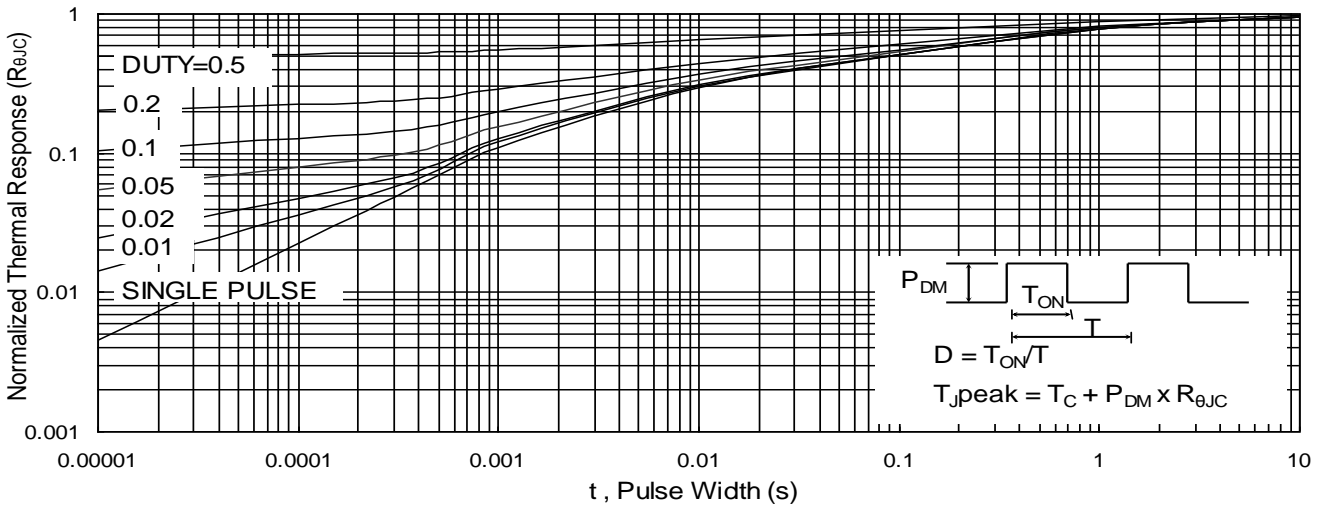

Fig.9 Normalized Maximum Transient Thermal Impedance

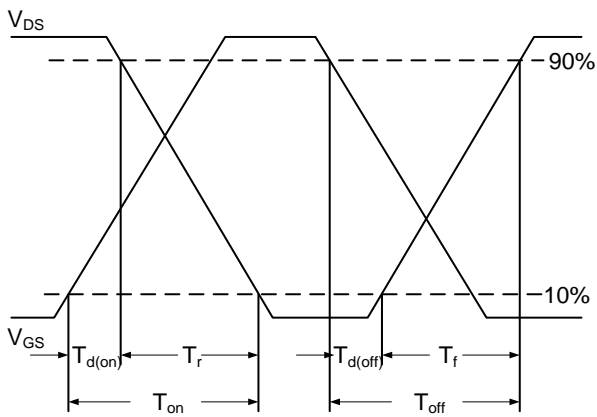

Fig.10 Switching Time Waveform

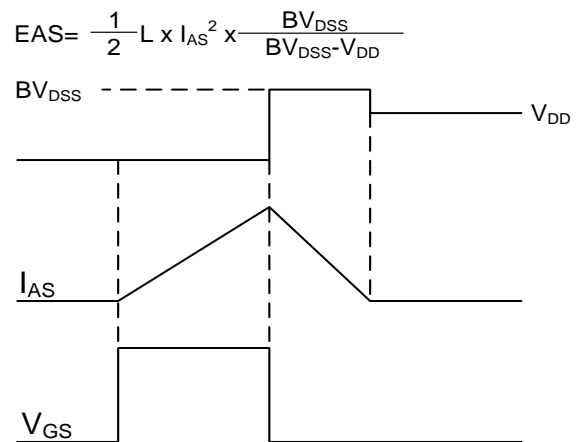
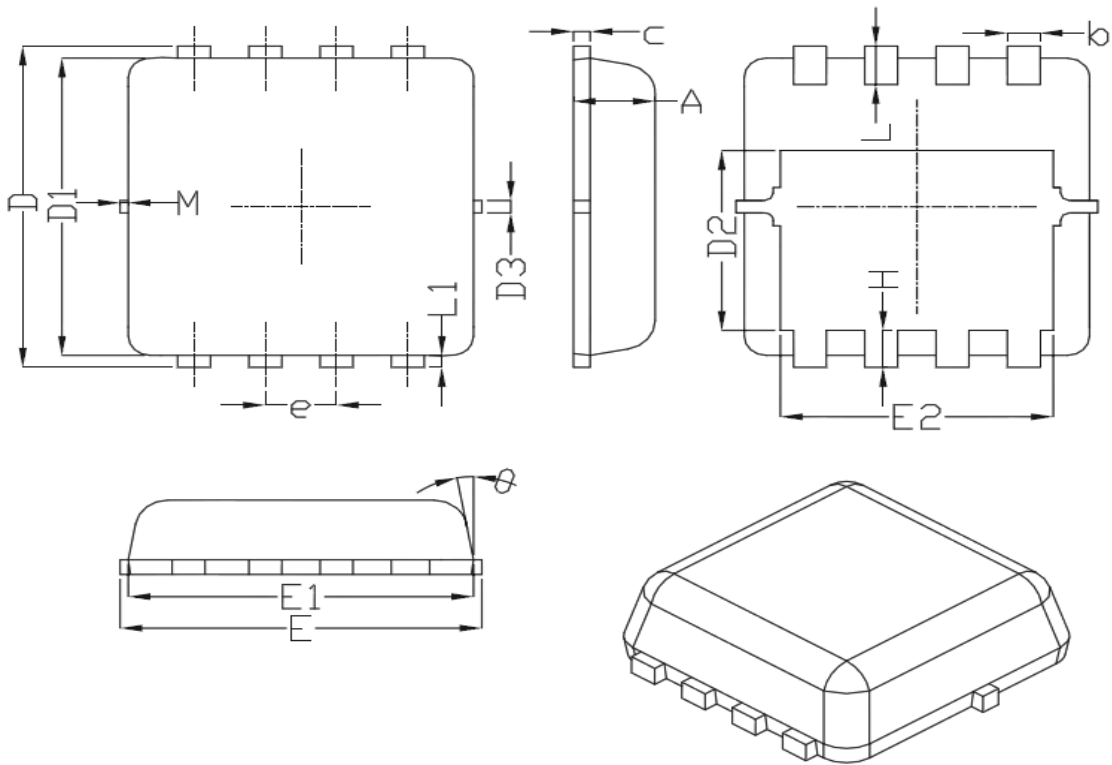

Fig.11 Unclamped Inductive Switching Waveform

Data and specifications subject to change without notice.

**PDFN3333 Package Outline Data**

**DIMENSIONS ( unit : mm )**

Symbol	Min	Typ	Max	Symbol	Min	Typ	Max
<b>A</b>	0.70	0.75	0.80	<b>b</b>	0.25	0.30	0.35
<b>C</b>	0.10	0.15	0.25	<b>D</b>	3.25	3.35	3.45
<b>D1</b>	3.00	3.10	3.20	<b>D2</b>	1.78	1.88	1.98
<b>D3</b>	--	0.13	--	<b>E</b>	3.20	3.30	3.40
<b>E1</b>	3.00	3.15	3.20	<b>E2</b>	2.39	2.49	2.59
<b>e</b>	0.65BSC			<b>H</b>	0.30	0.39	0.50
<b>L</b>	0.30	0.40	0.50	<b>L1</b>	--	0.13	--
<b>θ</b>	--	10°	12°	<b>M</b>	*	*	0.15

\*Not specified

Disclaimer:

The information provided in this document is believed to be accurate and reliable. however, Shenzhen Core Control Electronics Technology Co., Ltd. does not assume any responsibility for the following consequences Do not consider the use of such information or use beyond its scope.

The information mentioned in this document may be changed at any time without notice.

The products and information provided in this document do not infringe patents. Shenzhen Core Control Electronics Technology Co., Ltd. assumes no responsibility for any infringement of any other rights of third parties. The result of using such products and information.

This document is the second version issued on October 10, 2020. This document replaces and Replace all previously provided information.

 It is a registered trademark of Shenzhen Core Control Electronics Technology Co., Ltd.

Copyright © 2017 Shenzhen Core Control Electronics Technology Co., Ltd. all rights reserved.

## X-ON Electronics

Largest Supplier of Electrical and Electronic Components

*Click to view similar products for [MOSFET](#) category:*

*Click to view products by [AGM-Semi](#) manufacturer:*

Other Similar products are found below :

[IRFD120](#) [JANTX2N5237](#) [BUK455-60A/B](#) [MIC4420CM-TR](#) [VN1206L](#) [NDP4060](#) [SI4482DY](#) [IPS70R2K0CEAKMA1](#) [SQD23N06-31L-GE3](#)  
[TK16J60W,S1VQ\(O](#) [2SK2614\(TE16L1,Q\)](#) [DMN1017UCP3-7](#) [DMN1053UCP4-7](#) [SQJ469EP-T1-GE3](#) [NTE2384](#) [DMC2700UDMQ-7](#)  
[DMN2080UCB4-7](#) [DMN61D9UWQ-13](#) [US6M2GTR](#) [DMN31D5UDJ-7](#) [DMP22D4UFO-7B](#) [DMN1006UCA6-7](#) [DMN16M9UCA6-7](#)  
[STF5N65M6](#) [IRF40H233XTMA1](#) [STU5N65M6](#) [DMN6022SSD-13](#) [DMN13M9UCA6-7](#) [DMTH10H4M6SPS-13](#) [DMN2990UFB-7B](#)  
[IPB80P04P405ATMA2](#) [2N7002W-G](#) [MCAC30N06Y-TP](#) [MCQ7328-TP](#) [NTMC083NP10M5L](#) [BXP7N65D](#) [BXP4N65F](#) [AOL1454G](#)  
[WMJ80N60C4](#) [BXP2N20L](#) [BXP2N65D](#) [BXT1150N10J](#) [BXT1700P06M](#) [TSM60NB380CP](#) [ROG](#) [RQ7L055BGTGR](#) [DMNH15H110SK3-13](#)  
[SLF10N65ABV2](#) [BSO203SP](#) [BSO211P](#) [IPA60R230P6](#)