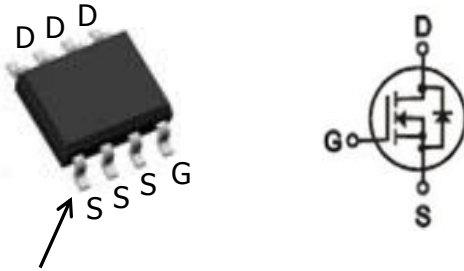

- ★ 100% EAS Guaranteed
- ★ Green Device Available
- ★ Super Low Gate Charge
- ★ Excellent CdV/dt effect decline
- ★ Advanced high cell density Trench technology

**Product Summary**

BVDSS	RDSON	ID
30V	6.5mΩ	13A

**SOP-8 Pin Configuration**

**Description**

AGM308S is the high cell density trenched N-ch MOSFETs, which provide excellent RDSON and gate charge for most of the synchronous buck converter applications.

**Package Marking and Ordering Information**

Device Marking	Device	Device Package	Reel Size	Tape width	Quantity
AGM308S	AGM308S	SOP-8	---mm	---mm	3000

**•Absolute Maximum Ratings (T<sub>C</sub> =25°C)**

Parameter	Symbol	Rating	Unit
Drain-Source Voltage	V <sub>DS</sub>	30	V
Gate-Source Voltage	V <sub>GS</sub>	±20	V
Continuous Drain Current <sup>②</sup>	I <sub>D</sub>	13	A
Pulsed Drain Current <sup>①</sup>	I <sub>DM</sub>	32	A
Total Power Dissipation <sup>②</sup>	P <sub>D@TC=25°C</sub>	3.1	W
Total Power Dissipation	P <sub>D@TA=25°C</sub>	0.69	W
Operating Junction Temperature	T <sub>J</sub>	-55 to 150	°C
Storage Temperature	T <sub>STG</sub>	-55 to 150	°C
Single Pulse Avalanche Energy@L=0.1mH	E <sub>AS</sub>	43	mJ
Avalanche Current@L=0.1mH	I <sub>AS</sub>	28	A

**•Thermal resistance**

Parameter	Symbol	Min.	Typ.	Max.	Unit
Thermal resistance, junction - case <sup>②</sup>	R <sub>thJC</sub>	-	-	40	°C/W
Thermal resistance, junction - ambient	R <sub>thJA</sub>	-	-	180	°C/W
Soldering temperature, wavesoldering for 10s	T <sub>sold</sub>	-	-	265	°C

**●Electronic Characteristics**

Parameter	Symbol	Condition	Min.	Typ	Max.	Unit
Drain-Source Breakdown Voltage	$BV_{DSS}$	$V_{GS} = 0V, I_D = 250\mu A$	30			V
Gate Threshold Voltage	$V_{GS(TH)}$	$V_{GS} = V_{DS}, I_D = 250\mu A$	1.2		2.5	V
Drain-Source Leakage Current	$I_{DSS}$	$V_{DS} = 30V, V_{GS} = 0V$			1.0	$\mu A$
Gate- Source Leakage Current	$I_{GSS}$	$V_{GS} = \pm 20V, V_{DS} = 0V$			$\pm 100$	nA
Static Drain-source On Resistance	$R_{DS(ON)}$	$V_{GS} = 10V, I_D = 12A$		6.5	9.5	m $\Omega$
		$V_{GS} = 4.5V, I_D = 6A$		10	14	m $\Omega$
Forward Transconductance	$g_{FS}$	$V_{DS} = 25V, I_D = 10A$		9		s

**●Electronic Characteristics**

Parameter	Symbol	Condition	Min.	Typ	Max.	Unit
Input capacitance	$C_{iss}$	f = 1MHz	-	980	-	pF
Output capacitance	$C_{oss}$		-	205	-	
Reverse transfer capacitance	$C_{rss}$		-	120	-	

**Gate Charge characteristics(Ta= 25°C)**

Parameter	Symbol	Condition	Min.	Typ	Max.	Unit
Total gate charge	$Q_g$	$V_{DD} = 25V$ $I_D = 8A$ $V_{GS} = 10V$	-	12	-	nC
Gate - Source charge	$Q_{gs}$		-	4	-	
Gate - Drain charge	$Q_{gd}$		-	6	-	

Note: ① Pulse Test : Pulse width  $\leq 300\mu s$ , Duty cycle  $\leq 2\%$  ;

② Device mounted on FR-4 substrate PC board, 2oz copper, with thermal bias to bottom layer 1inch square copper plate;

Fig.1 Power Dissipation

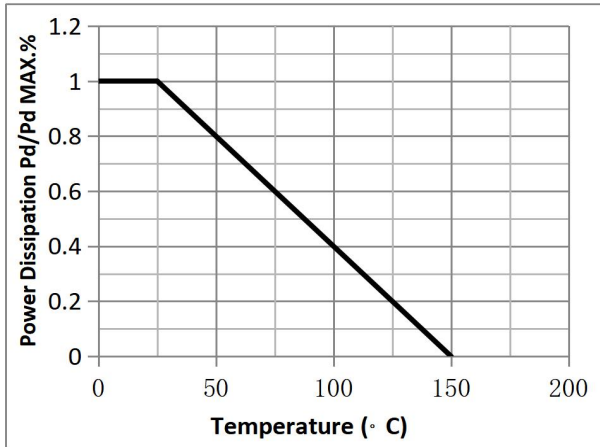

Fig.2 Typical output Characteristics

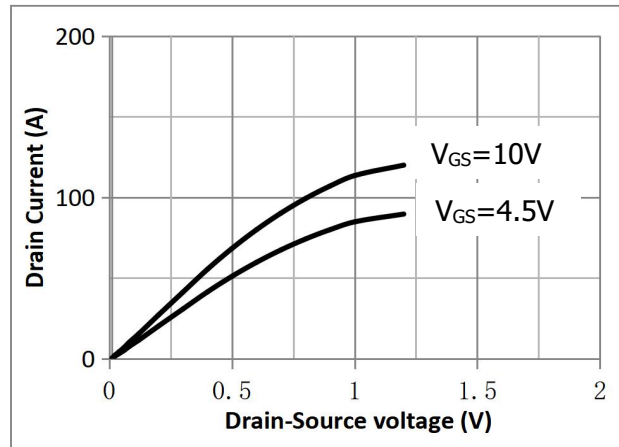

Fig.3 Threshold Voltage V.S Junction Temperature

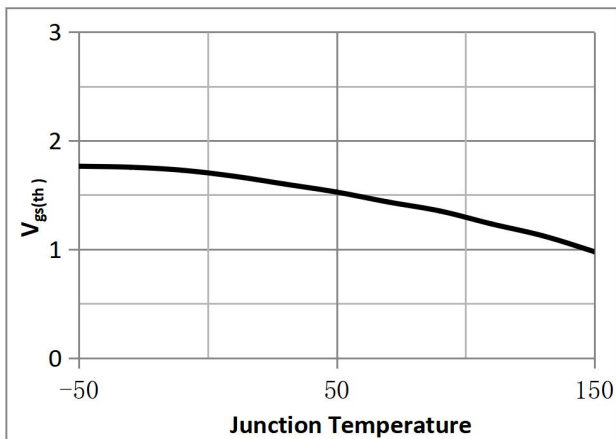

Fig.4 Resistance V.S Drain Current

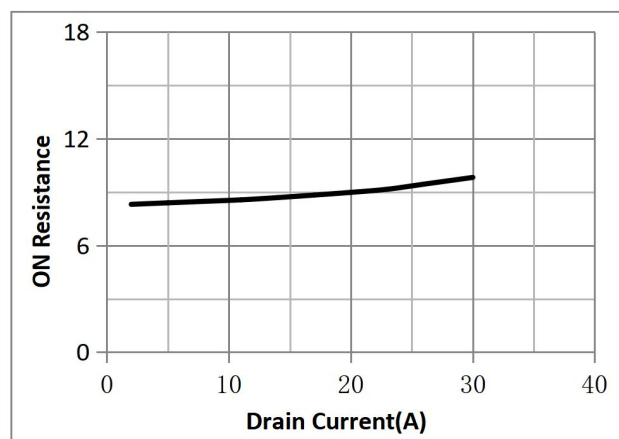

Fig.5 On-Resistance VS Gate Source Voltage

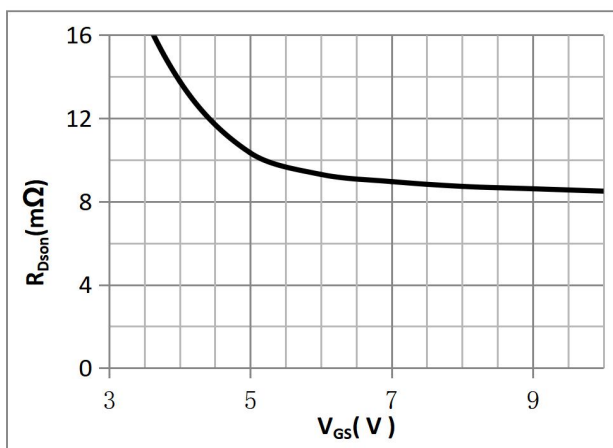

Fig.6 On-Resistance V.S Junction Temperature

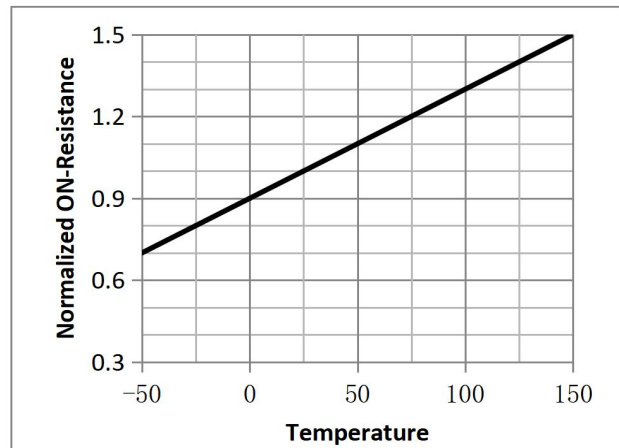

Fig.7 Switching Time Measurement Circuit

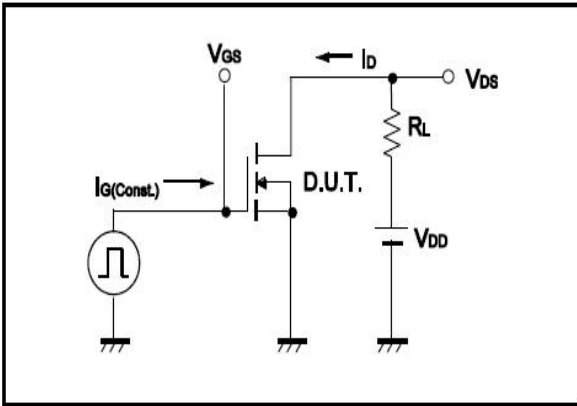

Fig.8 Gate Charge Waveform

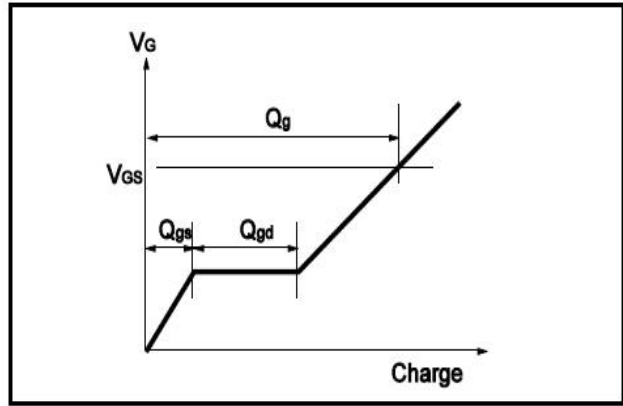

Fig.9 Switching Time Measurement Circuit

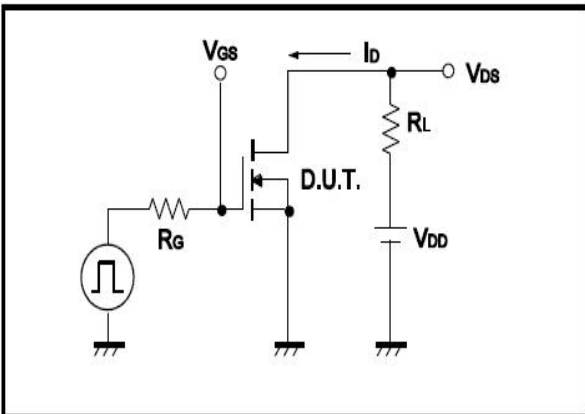

Fig.10 Gate Charge Waveform

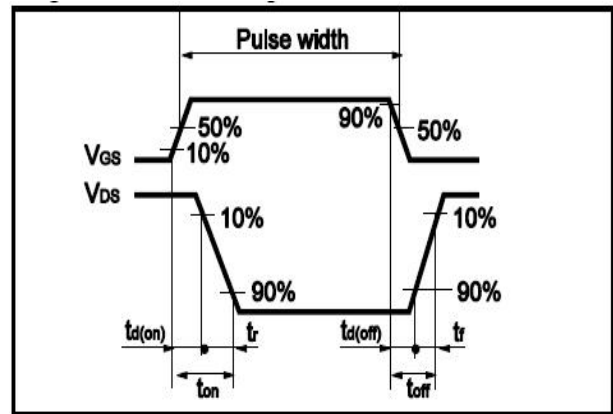

Fig.11 Avalanche Measurement Circuit

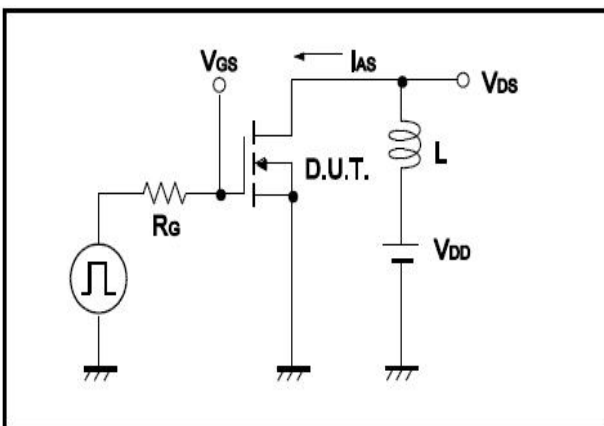
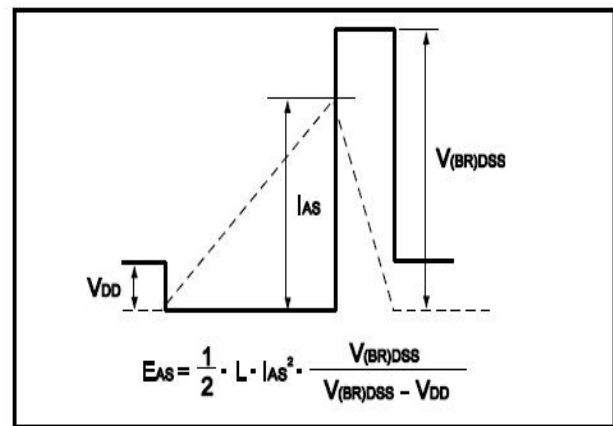
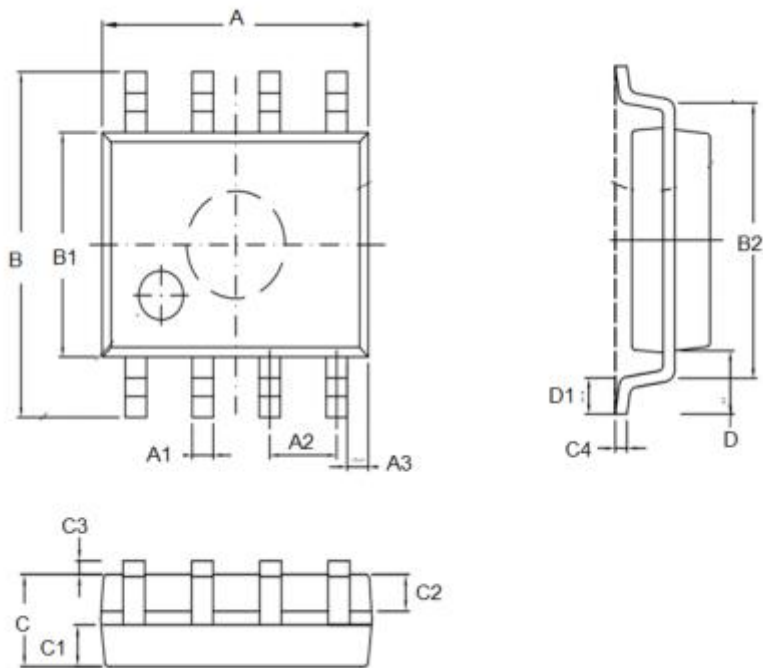

Fig.12 Avalanche Waveform



**●Dimensions(SOP8)**

SYMBOL	min	TYP	max	SYMBOL	min		max
A	4.80		5.00	C	1.30		1.50
A1	0.37		0.47	C1	0.55		0.75
A2		1.27		C2	0.55		0.65
A3		0.41		C3	0.05		0.20
B	5.80		6.20	C4	0.19	0.20	0.23
B1	3.80		4.00	D		1.05	
B2		5.00		D1	0.40		0.62



Disclaimers:

Information furnished in this document is believed to be accurate and reliable.

However,

Shenzhen Core Control Source Semiconductor Co., Ltd. assumes no responsibility for the consequences of

use without consideration for such information nor use beyond it.

Information mentioned in this document is subject to change without notice, apart from that

when an agreement is signed, Shenzhen core control source complies with the agreement.

Products and information provided in this document have no infringement of patents.

Shenzhen Core Control Source Semiconductor Co., Ltd. assumes no responsibility for any infringement of other rights of third parties which may result from the use of such products and information.

This document is the first version which is made in 12-Apr-21. This document supersedes and

replaces all information previously supplied.

 is a registered trademark of Shenzhen Core Control Source Semiconductor Co., Ltd.

Copyright ©2017 Shenzhen Core Control Source Semiconductor Co., Ltd. Printed All rights reserved.

## X-ON Electronics

Largest Supplier of Electrical and Electronic Components

*Click to view similar products for [MOSFET](#) category:*

*Click to view products by [AGM-Semi](#) manufacturer:*

Other Similar products are found below :

[IRFD120](#) [JANTX2N5237](#) [BUK455-60A/B](#) [MIC4420CM-TR](#) [VN1206L](#) [NDP4060](#) [SI4482DY](#) [IPS70R2K0CEAKMA1](#) [SQD23N06-31L-GE3](#)  
[TK16J60W,S1VQ\(O](#) [2SK2614\(TE16L1,Q\)](#) [DMN1017UCP3-7](#) [DMN1053UCP4-7](#) [SQJ469EP-T1-GE3](#) [NTE2384](#) [DMC2700UDMQ-7](#)  
[DMN2080UCB4-7](#) [DMN61D9UWQ-13](#) [US6M2GTR](#) [DMN31D5UDJ-7](#) [DMP22D4UFO-7B](#) [DMN1006UCA6-7](#) [DMN16M9UCA6-7](#)  
[STF5N65M6](#) [IRF40H233XTMA1](#) [STU5N65M6](#) [DMN6022SSD-13](#) [DMN13M9UCA6-7](#) [DMTH10H4M6SPS-13](#) [DMN2990UFB-7B](#)  
[IPB80P04P405ATMA2](#) [2N7002W-G](#) [MCAC30N06Y-TP](#) [MCQ7328-TP](#) [NTMC083NP10M5L](#) [BXP7N65D](#) [BXP4N65F](#) [AOL1454G](#)  
[WMJ80N60C4](#) [BXP2N20L](#) [BXP2N65D](#) [BXT1150N10J](#) [BXT1700P06M](#) [TSM60NB380CP](#) [ROG](#) [RQ7L055BGTGR](#) [DMNH15H110SK3-13](#)  
[SLF10N65ABV2](#) [BSO203SP](#) [BSO211P](#) [IPA60R230P6](#)