

## Dual USB High-Side Power Switch

### ■ FEATURES

- 110mΩ (5V Input) High-Side MOSFET Switch.
- 500mA Continuous Load Current per Channel.
- 110μA Typical On-State Supply Current.
- 1μA Typical Off-State Supply Current.
- Current-Limit / Short Circuit Protection.
- Thermal Shutdown Protection under Overcurrent Condition.
- Undervoltage Lockout Ensures that Switch is off at Start Up.
- Output can be Forced Higher than Input (Off-State).
- Open-Drain Fault Flag.
- Slow Turn ON and Fast Turn OFF.
- Enable Active-High or Active-Low.

### ■ APPLICATIONS

- USB Power Management.
- Hot Plug-In Power Supplies.
- Battery-Charger Circuit.

### ■ DESCRIPTION

The AIC1526 is a dual high-side power switch for self-powered and bus-powered Universal Serial Bus (USB) applications. One high-side switch is a MOSFET with 110mΩ  $R_{DS(ON)}$ , which meets USB voltage drop requirements for maximum transmission wire length.

Multi-purpose open-drain fault flag output indicates over-current limiting, thermal shutdown, or undervoltage lockout for each channel. Output current is typically limited to 1A, well below the 5A safety requirement, and the thermal shutdown function independently controls each channel under overcurrent condition.

Guaranteed minimum output rise time limits inrush current during hot plug-in, minimizing EMI and preventing the voltage at upstream port from dropping excessively.

## TYPICAL APPLICATION CIRCUIT

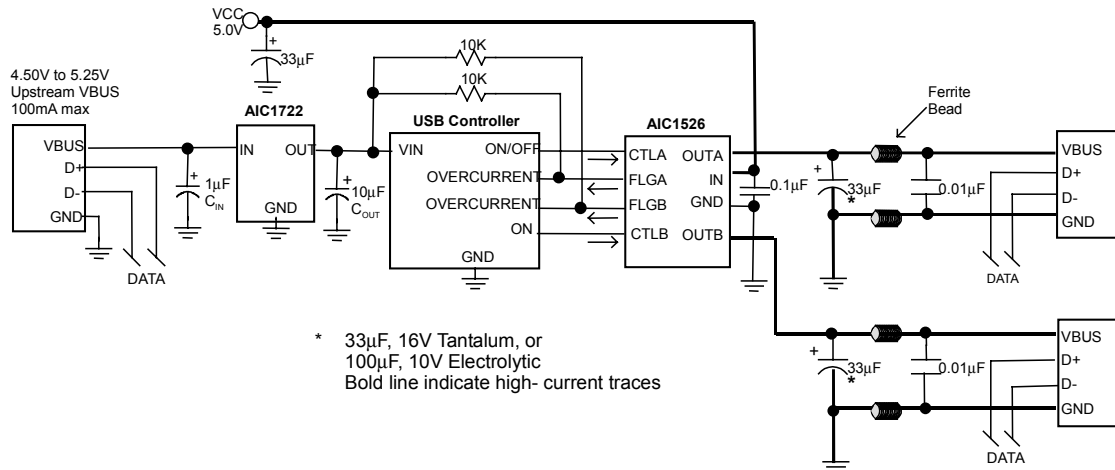

Two-Port Self-Powered Hub

## ORDERING INFORMATION

AIC1526-XXX

- PACKAGE TYPE  
N: PLASTIC DIP  
S: SMALL OUTLINE
- TEMPERATURE RANGE  
C: 0°C~+70°C
- CONTROL POLARITY  
0: ACTIVE LOW  
1: ACTIVE HIGH

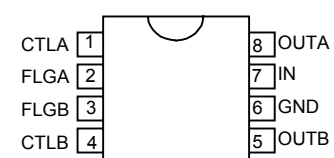
ORDER NUMBER	PIN CONFIGURATION
AIC1526-0CN AIC1526-1CN (PLASTIC DIP)	TOP VIEW 
AIC1526-0CS AIC1526-1CS (PLASTIC SO)	

## ABSOLUTE MAXIMUM RATINGS

Supply Voltage ( $V_{IN}$ )	7.0V
Fault Flag Voltage ( $V_{FLG}$ )	7.0V
Fault Flag Current ( $I_{FLG}$ )	50mA
Control Input ( $V_{CTL}$ )	-0.3V ~ 15V
Operating Temperature Range	-20°C~80°C
Storage Temperature Range	-65°C ~ 150°C

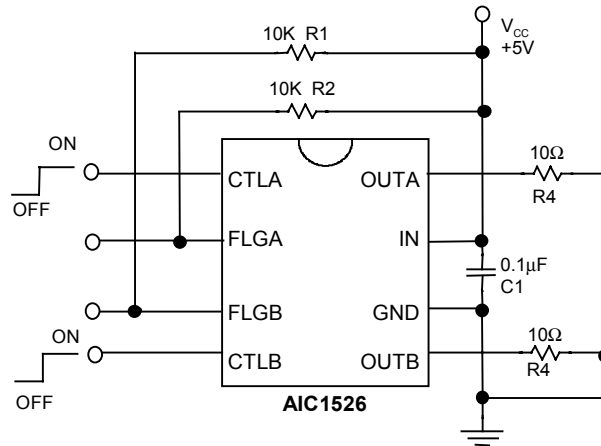
**TEST CIRCUIT**

**ELECTRICAL CHARACTERISTICS ( $V_{IN} = 5V$ ,  $T_a = 25^\circ C$ , unless otherwise specified.)**

PARAMETERS	CONDITIONS	MIN.	TYP.	MAX.	UNIT
Supply Current	$V_{CTL} = \text{Logic "0"}$ , OUT=Open $V_{CTL} = \text{Logic "1"}$ , OUT=Open		0.75 110	5 160	$\mu A$
Control Input Voltage	$V_{CTL} = \text{Logic "0"}$ $V_{CTL} = \text{Logic "1"}$			0.8	V
Control Input Current	$V_{CTL} = \text{Logic "0"}$ $V_{CTL} = \text{Logic "1"}$		0.01 0.01	1 1	$\mu A$
Control Input Capacitance			1		pF
Output MOSFET Resistance			110	150	m $\Omega$
Output Turn-On Rise Delay	$R_L = 10\Omega$ each Output		100		$\mu S$
Output Turn-On Rise Time	$R_L = 10\Omega$ each Output		1000	2500	$\mu S$
Output Turn-Off Delay	$R_L = 10\Omega$ each Output		0.8	20	$\mu S$
Output Turn-Off Fall Time	$R_L = 10\Omega$ each Output		0.7	20	$\mu S$
Output Leakage Current				10	$\mu A$
Current Limit Threshold		0.6	1.0	1.25	A
Overtemperature Shutdown Threshold	$T_J$ Increasing $T_J$ Decreasing		135 125		$^\circ C$
Error Flag Output Resistance	$V_{IN} = 5V$ , $I_L = 10\text{ mA}$ $V_{IN} = 3.3V$ , $I_L = 10\text{ mA}$		10 15	25 40	$\Omega$
Error Flag Off Current	$V_{FLG} = 5V$		0.01	1	$\mu A$
UVLO Threshold	$V_{IN}$ Increasing $V_{IN}$ Decreasing		2.6 2.4		V

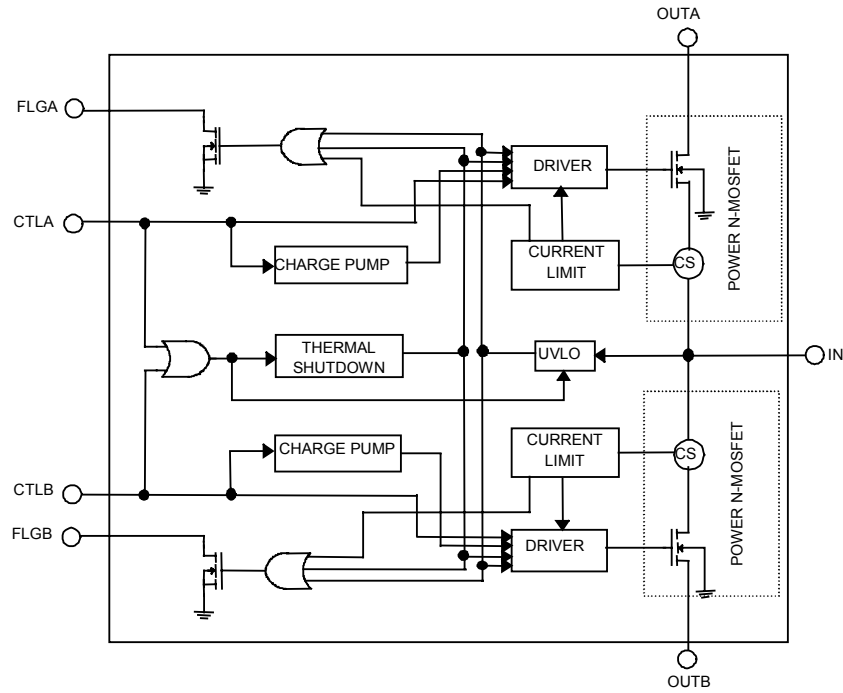
**■ BLOCK DIAGRAM**



**■ TYPICAL PERFORMANCE CHARACTERISTICS**

ON Resistance vs. Supply Voltage

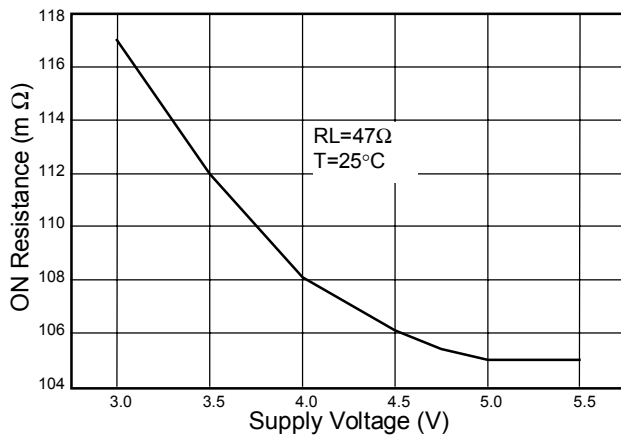

Output On Resistance vs. Temperature

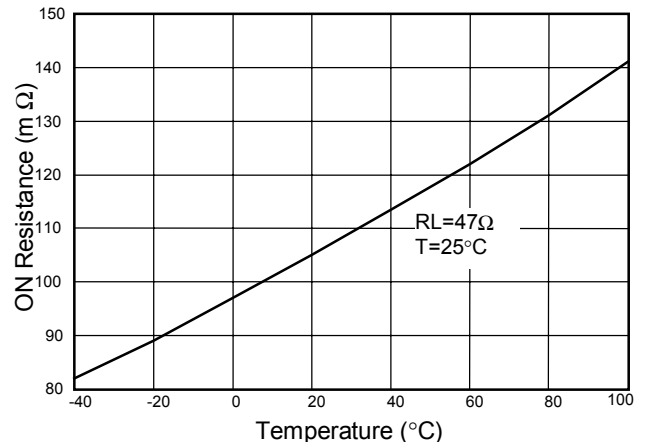

**TYPICAL PERFORMANCE CHARACTERISTICS (Continued)**

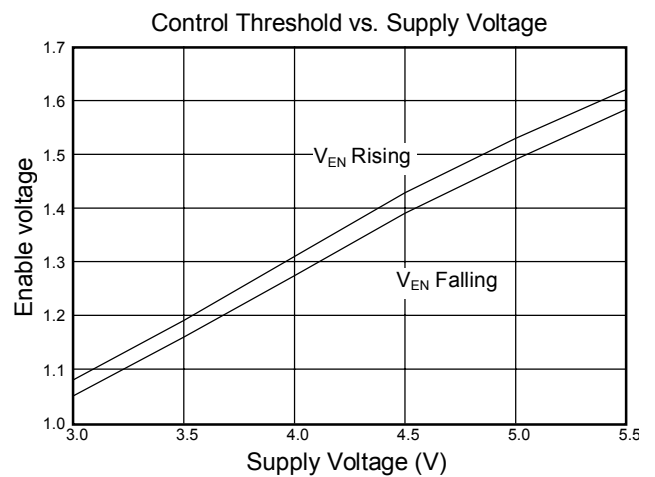
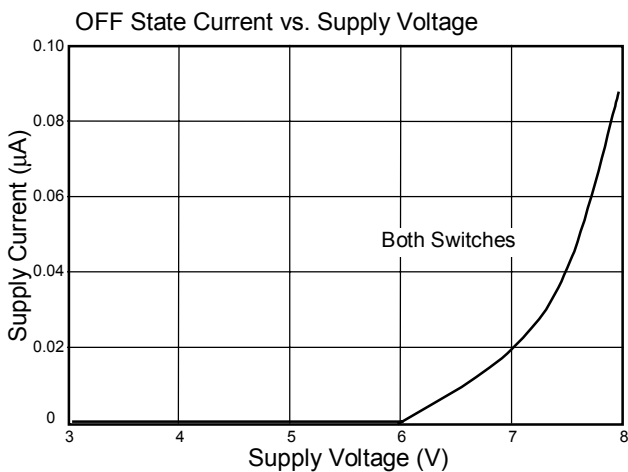
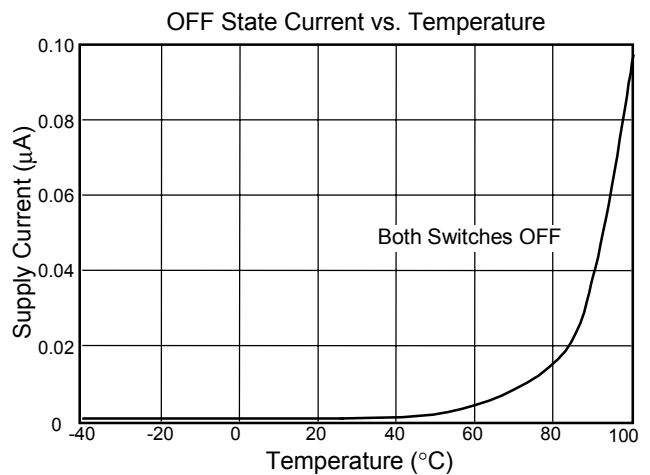
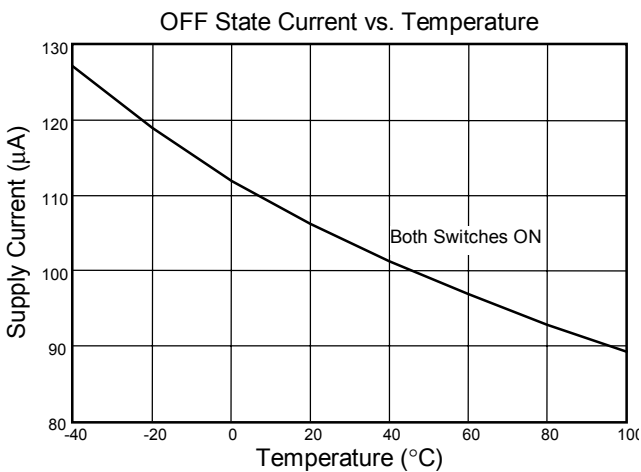
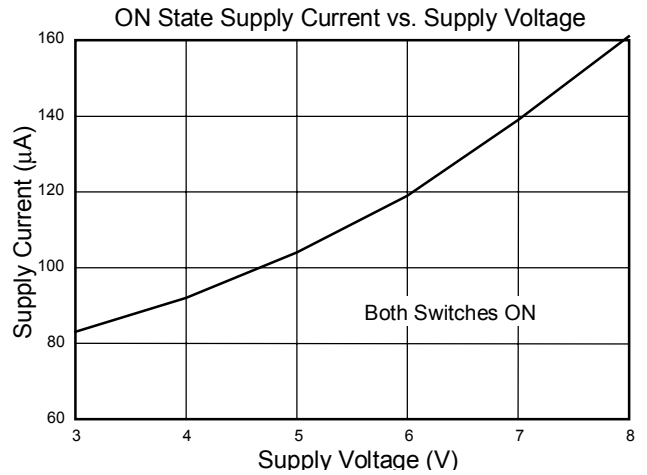
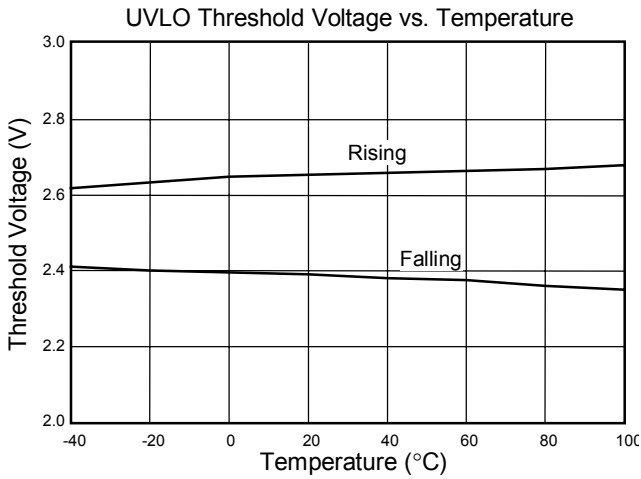

**TYPICAL PERFORMANCE CHARACTERISTICS (Continued)**

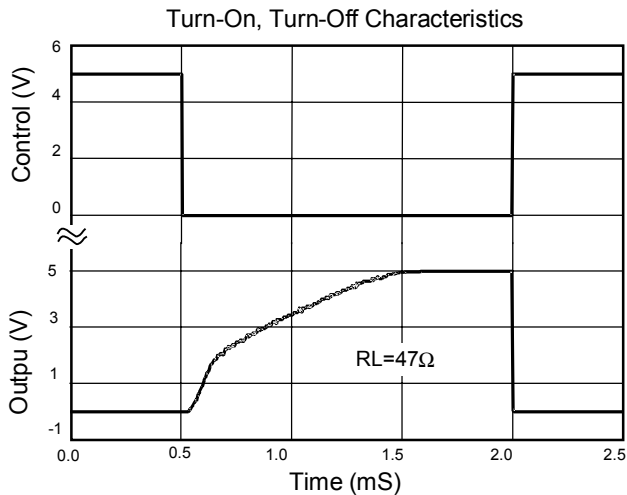

**PIN DESCRIPTION**

**PIN 1: CTLA** - TTL compatible control input. It controls the turn-on/turn-off of channel A MOSFET. Active high for AIC1526-1 and active low for AIC1526-0.

**PIN 2: FLGA** - An active-low and open-drained fault flag output for channel A. It can indicate current limit if CTLA is active. In normal mode operation (CTLA or/and CLTB is active), it also can indicate thermal shutdown or undervoltage.

**PIN 3: FLGB** - An active-low and open-drained fault flag output for channel B. It can indicate current limit if CTLB is active. In normal mode operation (CTLB or/and CLTA is active), it also can indicate thermal shutdown or undervoltage.

**PIN 4: CTLB** - TTL compatible control input. It controls the turn-on/turn-off of channel B MOSFET. Active High for AIC1526-1 and active low for AIC1526-0.

**PIN 5: OUTB** - Channel B MOSFET switch output.

**PIN 6: GND** - Chip power ground.

**PIN 7: IN** - Power supply input.

**PIN 8: OUTA** - Channel A MOSFET switch output.

## APPLICATION INFORMATION

### ● Error Flag

An open-drained output of an N-channel MOSFET, the FLG output is pulled low to signal the following fault conditions: input undervoltage, output current limit, and thermal shutdown.

### ● Current Limit

The current limit threshold is preset internally. It protects the output MOSFET switches from damage due to undesirable short circuit conditions or excess inrush current often encountered during hot plug-in. The low limit of the current limit threshold of the AIC1526 allows a minimum current of 0.5A through the MOSFET switches. A current limit condition will signal the error flag.

### ● Thermal Shutdown

When the chip temperature exceeds 135°C for any reason other than overcurrent fault of either one of the two MOSFET switches, the thermal shutdown function turns off both MOSFET switches and signal the error flag. A hysteresis of 10°C prevents the MOSFETs from turning back on until the chip temperature drops to below 125°C. However, if thermal shutdown is triggered by chip temperature rise due to overcurrent fault condition of either one of the MOSFET switches, the thermal shutdown function will only turn off the switch that is in overcurrent condition and the other switch can still remain its normal operation. In other words, the thermal shutdown function of the two switches is independent of each other in

the case of overcurrent fault.

### ● Supply Filtering

A 0.1μF to 1μF bypass capacitor from IN to GND, located near the device, is strongly recommended to control supply transients. Without a bypass capacitor, an output short may cause sufficient ringing on the input (from supply lead inductance) to damage internal control circuitry.

### ● Transient Droop Requirements

USB support dynamic attachment (hot plug-in) of peripherals. A current surge is caused by the input capacitance of downstream device. Ferrite beads are recommended in series with all power and ground connector pins. Ferrite beads reduce EMI and limit the inrush current during hot-attachment by filtering high-frequency signals.

### ● Short Circuit Transient

Bulk capacitance provides the short-term transient current needed during a hot-attachment event. With a 33μF, 16V tantalum or 100μF, 10V electrolytic capacitor mounted close to downstream connector per port should provide transient drop protection.

### ● Printed Circuit Layout

The power circuitry of USB printed circuit boards requires a customized layout to maximize thermal dissipation and to minimize voltage drop and EMI.

**PHYSICAL DIMENSION**

● 8 LEAD PLASTIC SO (unit: mm)

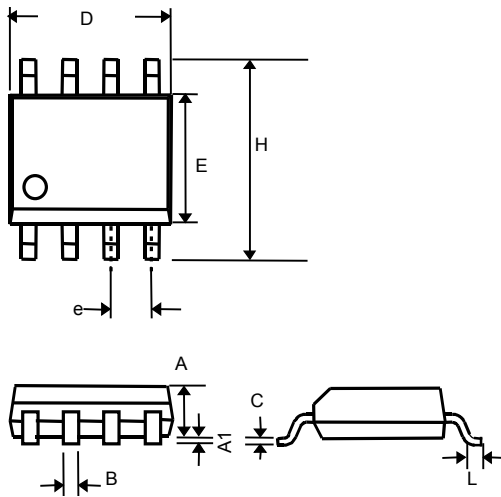

SYMBOL	MIN	MAX
A	1.35	1.75
A1	0.10	0.25
B	0.33	0.51
C	0.19	0.25
D	4.80	5.00
E	3.80	4.00
e	1.27(TYP)	
H	5.80	6.20
L	0.40	1.27

● 8 LEAD PLASTIC DIP (unit: mm)

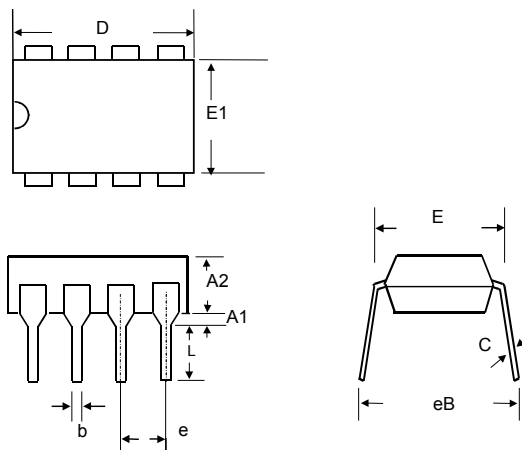

SYMBOL	MIN	MAX
A1	0.381	—
A2	2.92	4.96
b	0.35	0.56
C	0.20	0.36
D	9.01	10.16
E	7.62	8.26
E1	6.09	7.12
e	2.54 (TYP)	
eB	—	10.92
L	2.92	3.81



## X-ON Electronics

Largest Supplier of Electrical and Electronic Components

*Click to view similar products for [Power Switch ICs - Power Distribution category](#):*

*Click to view products by [AIC manufacturer](#):*

Other Similar products are found below :

[NCP45520IMNTWG-L](#) [TCK111G,LF\(S](#) [FPF1018](#) [DS1222](#) [TCK2065G,LF](#) [SZNCP3712ASNT3G](#) [TLE7244SL](#) [MIC2033-05BYMT-T5](#)  
[MIC2033-12AYMT-T5](#) [MIC2033-05BYM6-T5](#) [SLG5NT1437VTR](#) [SZNCP3712ASNT1G](#) [DML1008LDS-7](#) [KTS1640QGDV-TR](#)  
[KTS1641QGDV-TR](#) [NCV459MNWTBG](#) [NCP4545IMNTWG-L](#) [NCV8412ASTT1G](#) [NCV8412ASTT3G](#) [BTT3018EJXUMA1](#)  
[FPF2260ATMX](#) [SLG59M1557VTR](#) [BD2222G-GTR](#) [NCP45780IMN24RTWG](#) [NCP45540IMNTWG-L](#) [MC10XS6200EK](#) [MC10XS6225EK](#)  
[MC25XS6300EK](#) [MC33882PEP](#) [MC10XS6325EK](#) [TPS2021IDRQ1](#) [TPS2103D](#) [TPS22954DQCR](#) [TPS22958NDGKR](#) [TPS22994RUKR](#)  
[TPS2561AQDRCRQ1](#) [MIC2005-0.5YML-TR](#) [MIC2098-1YMT-TR](#) [MIC2098-2YMT-TR](#) [MIC94062YMT TR](#) [MIC94064YMT-TR](#)  
[MP6231DN-LF](#) [MP62551DGT-LF-P](#) [BTS117](#) [BTS500151TADATMA2](#) [VN540SP-E](#) [MIC2015-1.2YM6 TR](#) [MIC2026-2YM](#) [MIC2075-2YM](#)  
[MIC2095-2YMT-TR](#)