



FEATURES:

- Wide 4:1 Input Voltage Range
- High efficiency up to 91%
- 1500 VDC Isolation
- Over Current Protection
- Remote On/Off control
- Operating Temperature -40°C to +105°C
- Output Over Voltage protection
- Continuous Short Circuit Protection
- Input Under Voltage Protection
- Bare Part Meet CISPR32/EN55032 Class A



Models
Single output

| Model | Input Voltage (VDC) | Output Voltage (VDC) | Input Current max Full/No Load (mA) | Output Current max (mA) | Isolation (VDC) | Max Capacitive Load (uF) | Efficiency Typ. (%) |
|-----------------|---------------------|----------------------|-------------------------------------|-------------------------|-----------------|--------------------------|---------------------|
| AM15CW-2403S-NZ | 9-36 | 3.3 | 640/50 | 4000 | 1500 | 4700 | 88 |
| AM15CW-2405S-NZ | 9-36 | 5 | 710/50 | 3000 | 1500 | 4700 | 90 |
| AM15CW-2412S-NZ | 9-36 | 12 | 710/15 | 1250 | 1500 | 1000 | 90 |
| AM15CW-2415S-NZ | 9-36 | 15 | 703/15 | 1000 | 1500 | 820 | 91 |
| AM15CW-2424S-NZ | 9-36 | 24 | 703/20 | 625 | 1500 | 270 | 91 |
| AM15CW-4803S-NZ | 18-75 | 3.3 | 320/30 | 4000 | 1500 | 4700 | 88 |
| AM15CW-4805S-NZ | 18-75 | 5 | 356/30 | 3000 | 1500 | 4700 | 90 |
| AM15CW-4812S-NZ | 18-75 | 12 | 352/11 | 1250 | 1500 | 1000 | 91 |
| AM15CW-4815S-NZ | 18-75 | 15 | 352/11 | 1000 | 1500 | 820 | 91 |
| AM15CW-4824S-NZ | 18-75 | 24 | 352/11 | 625 | 1500 | 270 | 91 |

*Add suffix “-ST” for optional screw terminal bottom plate or “-STD” for optional DIN Rail screw terminal bottom plate.

**Add suffix “-K” for optional heatsink, “-K-ST” for optional heatsink and screw terminal bottom plate or “-K-STD” for optional heatsink and DIN Rail screw terminal bottom plate.

Models
Dual output

| Model | Input Voltage (VDC) | Output Voltage (VDC) | Input Current max Full/No Load (mA) | Output Current max (mA) | Isolation (VDC) | Max Capacitive Load (uF) | Efficiency Typ. (%) |
|------------------|---------------------|----------------------|-------------------------------------|-------------------------|-----------------|--------------------------|---------------------|
| AM15CW-2405D-NZ✘ | 9-36 | ± 5 | 710/50 | ± 1500 | 1500 | ± 1500 | 87 |
| AM15CW-2412D-NZ✘ | 9-36 | ± 12 | 710/15 | ± 625 | 1500 | ± 470 | 90 |
| AM15CW-2415D-NZ✘ | 9-36 | ± 15 | 703/15 | ± 500 | 1500 | ± 330 | 90 |
| AM15CW-2424D-NZ✘ | 9-36 | ± 24 | 703/20 | ± 312 | 1500 | ± 200 | 89 |
| AM15CW-4805D-NZ✘ | 18-75 | ± 5 | 356/30 | ± 1500 | 1500 | ± 1500 | 86 |
| AM15CW-4812D-NZ✘ | 18-75 | ± 12 | 352/11 | ± 625 | 1500 | ± 470 | 90 |
| AM15CW-4815D-NZ✘ | 18-75 | ± 15 | 352/11 | ± 500 | 1500 | ± 330 | 90 |
| AM15CW-4824D-NZ✘ | 18-75 | ± 24 | 352/11 | ± 312 | 1500 | ± 200 | 90 |

*Add suffix “-ST” for optional screw terminal bottom plate or “-STD” for optional DIN Rail screw terminal bottom plate.

NOTE: All specifications in this datasheet are measured at an ambient temperature of 25°C, humidity<75%, nominal input voltage and at rated output load unless otherwise specified.

Input Specifications

| Parameters | Nominal | Typical | Maximum | Units |
|--------------------------------|-------------------------------|---|------------|-------|
| Voltage range | 24 Vin | 9-36 | | VDC |
| | 48 Vin | 18-75 | | |
| Filter | | Pi | | |
| Absolute Maximum Rating (1s) | 24 Vin | | -0.7 – 50 | VDC |
| | 48 Vin | | -0.7 – 100 | |
| Input reflected ripple current | Nominal input, | 30 | | mA |
| Input Under voltage protection | 24 Vin | 6.5 | | VDC |
| | 48 Vin | 15.5 | | |
| Startup time | Nominal input, resistive load | 10 | | ms |
| Remote On/Off Control | On Off | 3.5-12VDC or leave open 0-1.2VDC or connect to GND, idle current 2-7mA | | |

Isolation Specifications

| Parameters | Conditions | Typical | Maximum | Units |
|--------------------|------------------|---------|---------|-------|
| Tested I/O voltage | 60 sec, <1mA | 1500 | | VDC |
| Resistance | 500VDC | >1000 | | MOhm |
| Capacitance | I/O, 100KHz/0.1V | 2000 | | pF |

Output Specifications

| Parameters | Conditions | Typical | Maximum | Units | |
|------------------------------|--|---------------|---------|-----------|--------|
| Voltage accuracy | 0% to 100% load | ±1 | ±3 | % | |
| Over voltage protection | | 110-160 | | % of Vout | |
| Over current protection | Single output | 110-190 | | % of Iout | |
| | Dual output | 110-270 | | | |
| Short Circuit protection | Continuous | | | | |
| Short circuit restart | Auto-Recovery | | | | |
| Line voltage regulation | Full load, LL to HL , Positive output | ±0.2 | ±0.5 | % of Vin | |
| | Full load, LL to HL , Negative output | ±0.4 | ±1 | | |
| Load voltage regulation | 5% to 100% load | ±0.5 | ±1 | % | |
| Cross Regulation | Dual output , main circuit with 50% load, auxiliary circuit with 10%-100% load | | ±5 | % | |
| Temperature coefficient | 100% load | | ±0.03 | %/°C | |
| Ripple & Noise | 20MHz Bandwidth, 5-100% load | Single output | 50 | 100 | mV p-p |
| | | Dual output | 100 | 200 | |
| Transient recovery time | 25% load step change | 0.3 | 0.5 | ms | |
| Transient recovery deviation | 25% load step change | 3.3/5V output | ±3 | ±8 | % |
| | | Others | ±3 | ±5 | |

General Specifications

| Parameters | Conditions | Typical | Maximum | Units |
|-------------------------------|---|---------------------------|--------------------------|-------|
| Switching frequency | 100% load | Single 3.3/5V output | 300 | KHz |
| | | Others | 270 | |
| Operating temperature | See derating curve | Single 3.3/5V output | -40 to +95 | |
| | | Others | -40 to +105 | |
| Storage temperature | | -55 to +125 | | °C |
| Cooling | Free air convection | | | |
| Humidity | | | 95 | % RH |
| Case material | Aluminum Alloy | | | |
| Weight | Pin mountable | 15 | | g |
| | With optional -ST mounting plate: | 38 | | |
| | With optional -STD mounting plate: | 58 | | |
| | With optional -K Pin mountable | 20 | | |
| | With optional -ST-K mounting plate: | 42 | | |
| | With optional -STD-K mounting plate: | 62 | | |
| Dimensions (L x W x H) | Pin mountable | 1 x 1 x 0.46 inches | 25.40 x 25.40 x 11.70 mm | |
| | With optional -ST mounting plate: | 2.99 x 1.24 x 0.84 inches | 76.00 x 31.50 x 21.20 mm | |
| | With optional -STD mounting plate: | 2.99 x 1.24 x 1.02 inches | 76.00 x 31.50 x 25.80 mm | |
| | With optional -K Pin mountable | 1 x 1 x 0.64 inches | 25.40 x 25.40 x 16.20 mm | |
| | With optional -ST-K mounting plate: | 2.99 x 1.24 x 0.99 inches | 76.00 x 31.50 x 25.20 mm | |
| | With optional -STD-K mounting plate: | 2.99 x 1.24 x 1.17 inches | 76.00 x 31.50 x 29.80 mm | |
| MTBF | >1,000,000 hours (MIL-HDBK -217F, Ground Benign, t=+25°C) | | | |
| Maximum soldering temperature | 1.5mm from case for 10 sec | | 300 | °C |

Safety Specifications

| Parameters | |
|------------------|--|
| Agency approvals | CE EN62368-1; cULus UL62368-1 (✘ with exception of dual output models) |
| | CISPR32 / EN 55032, Class A / Class B with the recommended EMC circuit |
| | Information technology Equipment Designed to meet IEC62368-1 |
| | Electrostatic Discharge Immunity IEC 61000-4-2, Contact ±6KV, Air ±8KV, Criteria B |
| | RF, Electromagnetic Field Immunity IEC 61000-4-3, 10V/m, Criteria A |
| | Electrical Fast Transient / Burst Immunity IEC 61000-4-4, ±2KV with the recommended EMC circuit, Criteria A |

| | |
|------------------------------------|--|
| Surge Immunity | IEC 61000-4-5, L-L ± 2 KV with the recommended EMC circuit, Criteria B |
| RF, Conducted Disturbance Immunity | IEC 61000-4-6, 3 Vrms, Criteria A |

Dimensions

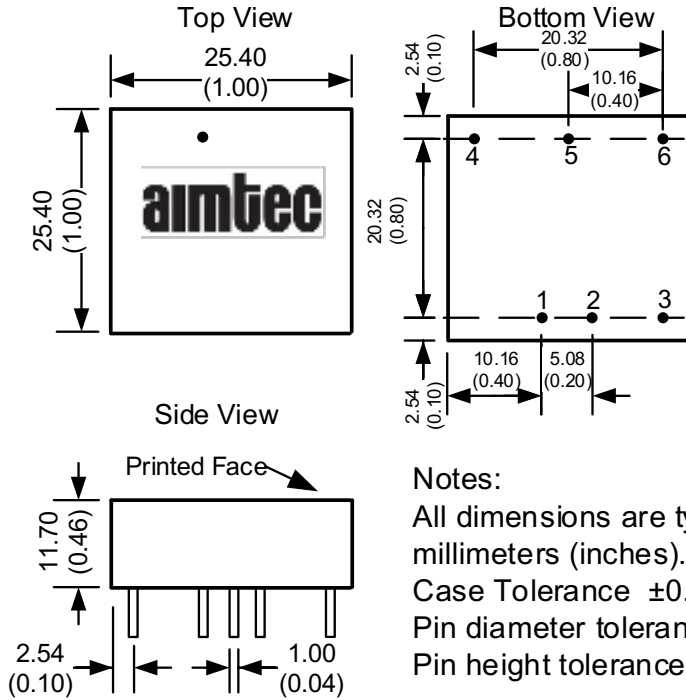

Notes:

- All dimensions are typical in millimeters (inches).
- Case Tolerance ± 0.25 (± 0.01)
- Pin diameter tolerance ± 0.1 (± 0.004)
- Pin height tolerance ± 0.5 (± 0.02)

Pin Out Specifications

| Pin | Single | Dual |
|-----|----------------|----------------|
| 1 | +V Input | +V Input |
| 2 | -V Input | -V Input |
| 3 | On/Off Control | On/Off Control |
| 4 | +V Output | +V Output |
| 5 | Trim | Common |
| 6 | -V Output | -V Output |

Heatsink Option: AM15CW-NZ-K

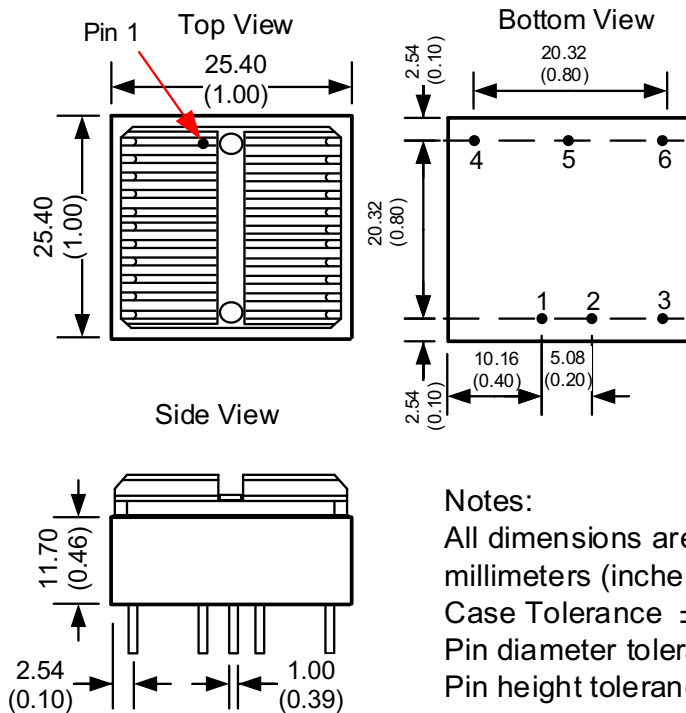

Notes:

- All dimensions are typical in millimeters (inches).
- Case Tolerance ± 0.25 (± 0.01)
- Pin diameter tolerance ± 0.1 (± 0.004)
- Pin height tolerance ± 0.5 (± 0.02)

Screw Terminal Option: AM15CW-NZ-ST

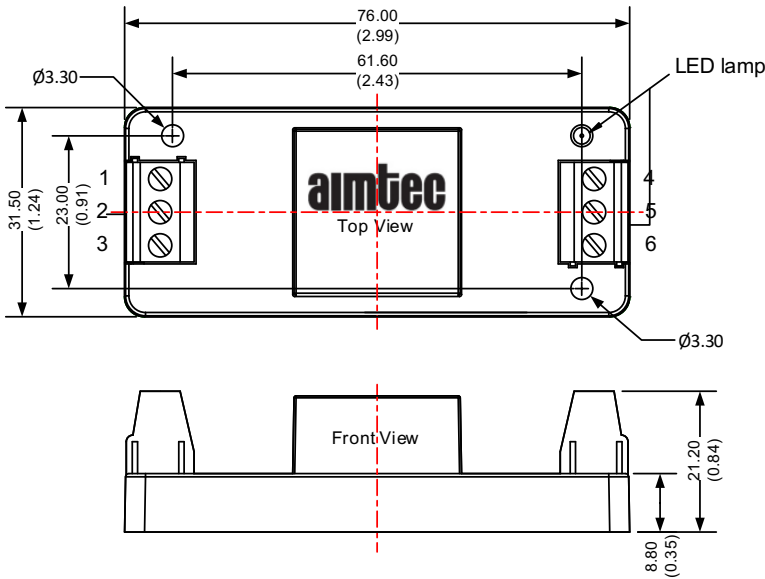

Pin Out Specifications

| Pin | Single | Dual |
|-----|-------------|-------------|
| 1 | On/off Ctrl | On/off Ctrl |
| 2 | -V Input | -V Input |
| 3 | +V Input | +V Input |
| 4 | -V Output | -V Output |
| 5 | Trim | Common |
| 6 | +V Output | +V Output |

Note:
Unit: mm (inch)
Wire range: 24-12 AWG
Tightening torque: Max 0.4 N*m
General tolerances: ± 0.50 (± 0.02)

Screw Terminal with heatsink Option: AM15CW-NZ-K-ST

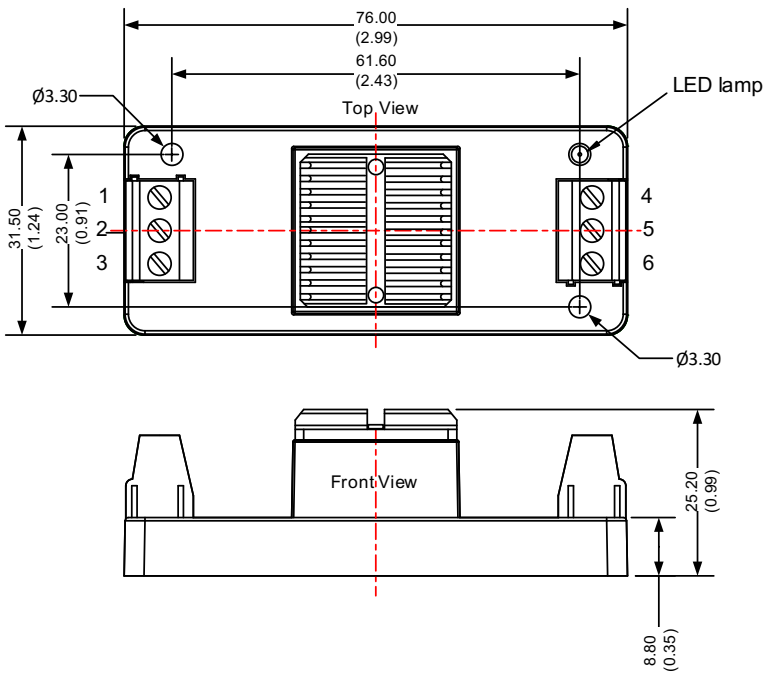

Note:
Unit: mm (inch)
Wire range: 24-12 AWG
Tightening torque: Max 0.4 N*m
General tolerances: ± 0.50 (± 0.02)

DIN-RAIL Option: AM15CW-NZ-STD

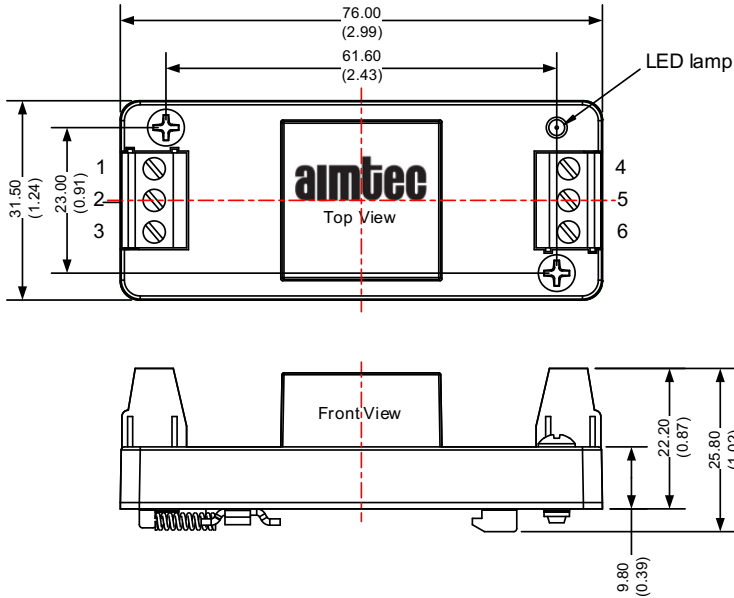

Pin Out Specifications

| Pin | Single | Dual |
|-----|-------------|-------------|
| 1 | On/off Ctrl | On/off Ctrl |
| 2 | -V Input | -V Input |
| 3 | +V Input | +V Input |
| 4 | -V Output | -V Output |
| 5 | Trim | Common |
| 6 | +V Output | +V Output |

Note:
Unit: mm (inch)
Mounting rail: TS35
Wire range: 24-12 AWG
Tightening torque: Max 0.4 N*m
General tolerances: ± 0.50 (± 0.02)

DIN-RAIL with heatsink Option: AM15CW-NZ-K-STD

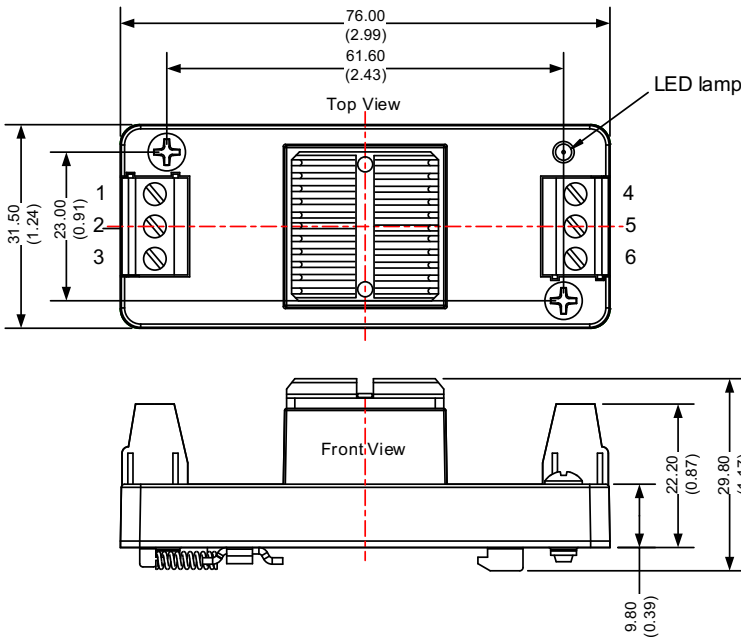

Note:
Unit: mm (inch)
Mounting rail: TS35
Wire range: 24-12 AWG
Tightening torque: Max 0.4 N*m
General tolerances: ± 0.50 (± 0.02)

Derating

Single output

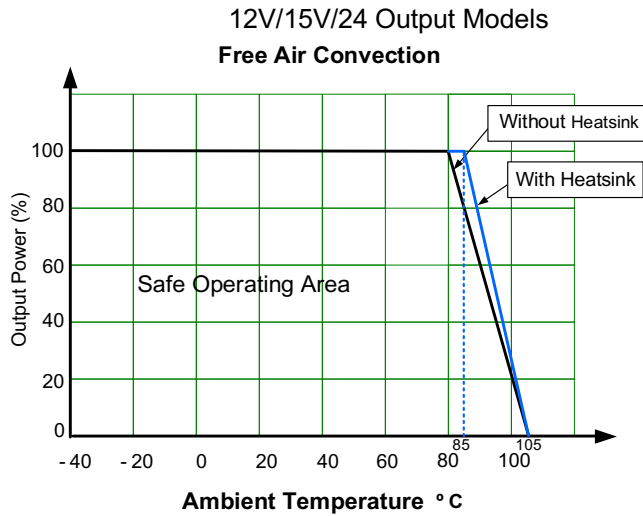
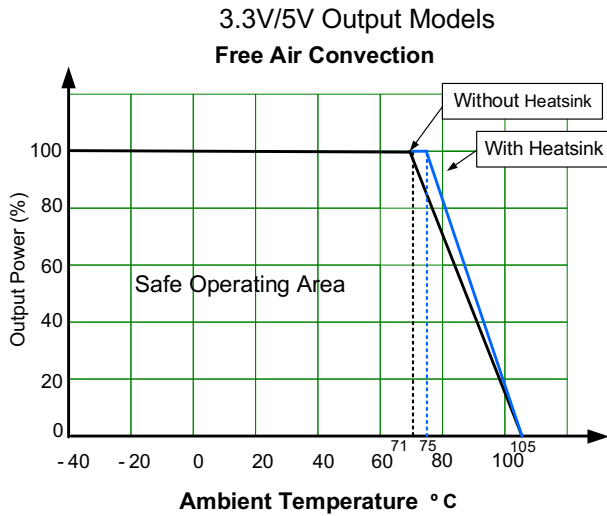

Dual output

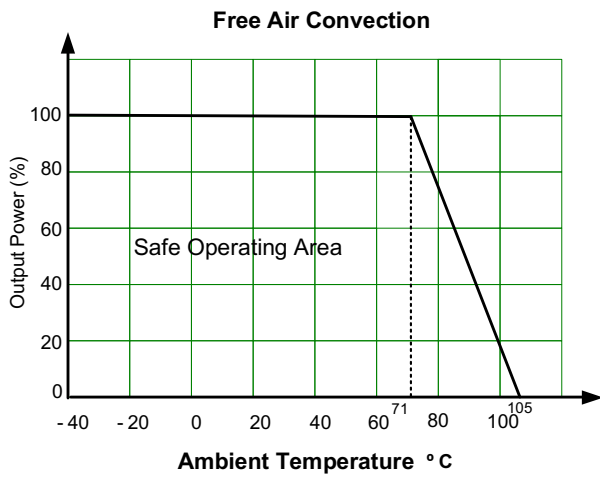

Typical Application Circuits

Single output

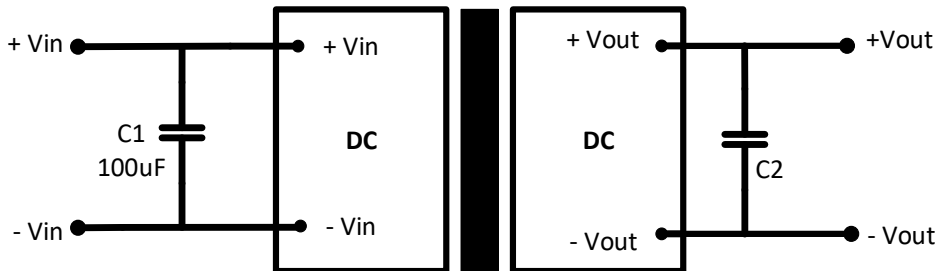

| Model | 3.3V/5V/12V/15V Vout | 24V Vout |
|-------|----------------------|----------|
| C2 | 100µF | 47µF |

Dual output

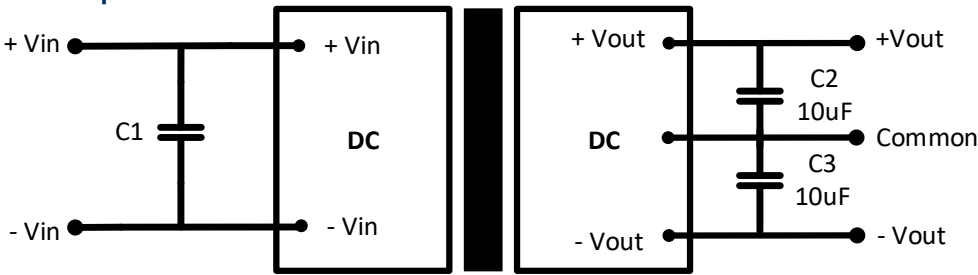

| Model | 12V/24V Vin | 48V Vin |
|-------|-------------|-------------------------|
| C1 | 100 μ F | 10 μ F - 47 μ F |

Recommended EMC Circuits

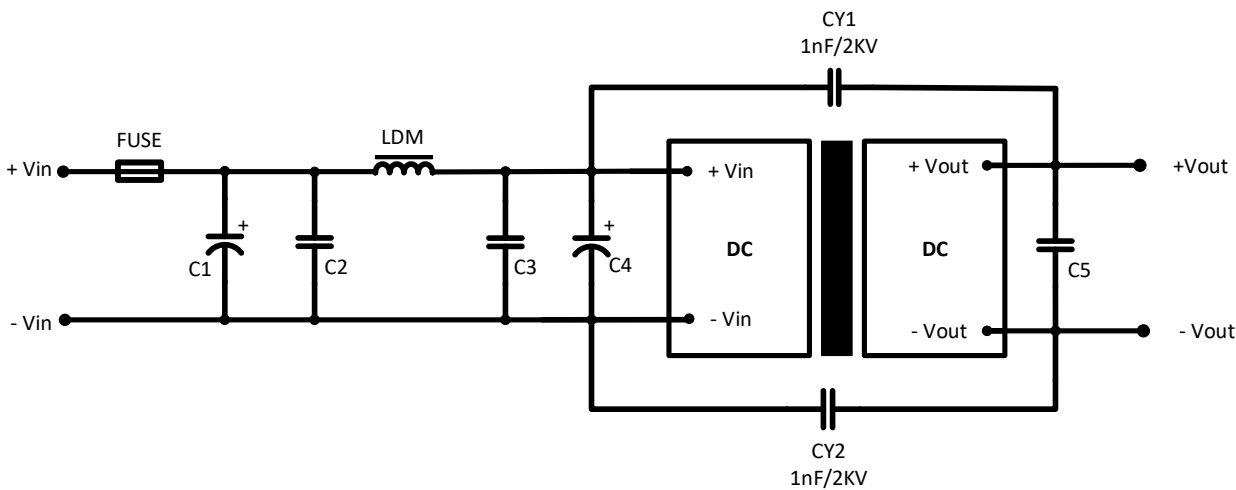

Single output

| Model | 12V/24V Vin | 48V Vin |
|--------|--|------------------|
| FUSE | Choose based on actual input current | |
| C1, C4 | 330 μ F/50V | 330 μ F/100V |
| C2, C3 | 4.7 μ F/50V | 4.7 μ F/100V |
| LDM | 2.2 μ H/4A | 2.2 μ H/2A |
| C5 | Refer to the C2 in typical application circuit | |

Dual output

| Model | 12V/24V Vin | 48V Vin |
|--------|---|------------------|
| FUSE | Choose based on actual input current | |
| C1, C4 | 330 μ F/50V | 330 μ F/100V |
| C2, C3 | 4.7 μ F/50V | 4.7 μ F/100V |
| LDM | 4.7 μ H | |
| C5 | Refer to the C2/C3 in typical application circuit | |

Trimming (Single output)

Output voltage can be externally trimmed by utilizing the methods as shown below

Fixed Resistor

Variable Potentiometer

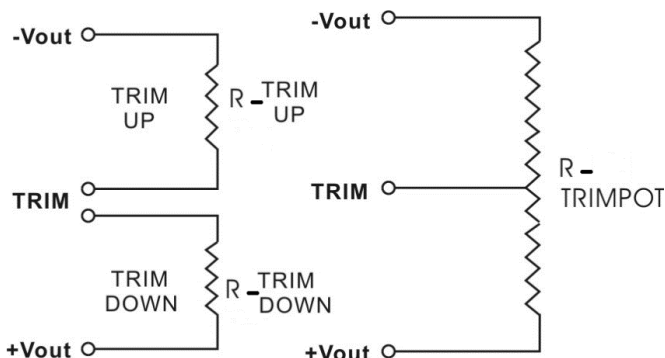

Leave open if not used.

3.3V output models

| | | | | | | | | | | |
|--------------|---------|---------|--------|--------|--------|--------|--------|--------|--------|-------|
| Trim down % | 1 | 2 | 3 | 4 | 5 | 6 | 7 | 8 | 9 | 10 |
| Vout (VDC) | 3.267 | 3.234 | 3.201 | 3.168 | 3.135 | 3.102 | 3.069 | 3.036 | 3.003 | 2.97 |
| Rt down (KΩ) | 190.744 | 104.218 | 68.096 | 48.270 | 35.741 | 27.108 | 20.797 | 15.983 | 12.190 | 9.124 |
| Trim up % | 1 | 2 | 3 | 4 | 5 | 6 | 7 | 8 | 9 | 10 |
| Vout (VDC) | 3.333 | 3.366 | 3.399 | 3.432 | 3.465 | 3.498 | 3.531 | 3.564 | 3.597 | 3.63 |
| Rt up (KΩ) | 303.349 | 100.149 | 55.286 | 35.580 | 24.504 | 17.407 | 12.472 | 8.842 | 6.058 | 3.857 |

5V output models

| | | | | | | | | | | |
|--------------|---------|--------|--------|--------|--------|--------|--------|-------|-------|-------|
| Trim down % | 1 | 2 | 3 | 4 | 5 | 6 | 7 | 8 | 9 | 10 |
| Vout (VDC) | 4.95 | 4.9 | 4.85 | 4.8 | 4.75 | 4.7 | 4.65 | 4.6 | 4.55 | 4.5 |
| Rt down (KΩ) | 89.996 | 47.446 | 29.793 | 20.131 | 14.036 | 9.840 | 6.775 | 4.439 | 2.598 | 1.111 |
| Trim up % | 1 | 2 | 3 | 4 | 5 | 6 | 7 | 8 | 9 | 10 |
| Vout (VDC) | 5.05 | 5.1 | 5.15 | 5.2 | 5.25 | 5.3 | 5.35 | 5.4 | 5.45 | 5.5 |
| Rt up (KΩ) | 238.676 | 81.473 | 46.044 | 30.398 | 21.581 | 15.923 | 11.985 | 9.085 | 6.861 | 5.101 |

12V output models

| | | | | | | | | | | |
|--------------|---------|---------|---------|---------|---------|---------|--------|--------|--------|--------|
| Trim down % | 1 | 2 | 3 | 4 | 5 | 6 | 7 | 8 | 9 | 10 |
| Vout (VDC) | 11.88 | 11.76 | 11.64 | 11.52 | 11.4 | 11.28 | 11.16 | 11.04 | 10.92 | 10.8 |
| Rt down (KΩ) | 493.692 | 299.052 | 210.127 | 159.185 | 126.173 | 103.042 | 85.932 | 72.764 | 62.316 | 53.823 |
| Trim up % | 1 | 2 | 3 | 4 | 5 | 6 | 7 | 8 | 9 | 10 |
| Vout (VDC) | 12.12 | 12.24 | 12.36 | 12.48 | 12.6 | 12.72 | 12.84 | 12.96 | 13.08 | 13.2 |
| Rt up (KΩ) | 704.035 | 156.520 | 81.479 | 51.675 | 35.677 | 25.695 | 18.874 | 13.917 | 10.152 | 7.195 |

15V output models

| | | | | | | | | | | |
|--------------|----------|---------|---------|---------|---------|---------|---------|---------|--------|--------|
| Trim down % | 1 | 2 | 3 | 4 | 5 | 6 | 7 | 8 | 9 | 10 |
| Vout (VDC) | 14.85 | 14.7 | 14.55 | 14.4 | 14.25 | 14.1 | 13.95 | 13.8 | 13.65 | 13.5 |
| Rt down (KΩ) | 632.483 | 398.237 | 286.114 | 220.359 | 177.137 | 146.560 | 123.787 | 106.169 | 92.132 | 80.687 |
| Trim up % | 1 | 2 | 3 | 4 | 5 | 6 | 7 | 8 | 9 | 10 |
| Vout (VDC) | 15.15 | 15.3 | 15.45 | 15.6 | 15.75 | 15.9 | 16.05 | 16.2 | 16.35 | 16.5 |
| Rt up (KΩ) | 1457.699 | 190.174 | 94.242 | 58.954 | 40.616 | 29.381 | 21.791 | 16.321 | 12.190 | 8.961 |

24V output models

| | | | | | | | | | | |
|--------------|----------|---------|---------|---------|---------|---------|---------|---------|---------|---------|
| Trim down % | 1 | 2 | 3 | 4 | 5 | 6 | 7 | 8 | 9 | 10 |
| Vout (VDC) | 23.76 | 23.52 | 23.28 | 23.04 | 22.8 | 22.56 | 22.32 | 22.08 | 21.84 | 21.6 |
| Rt down (KΩ) | 1284.000 | 789.923 | 563.667 | 433.904 | 349.754 | 290.763 | 247.115 | 213.514 | 186.847 | 165.170 |
| Trim up % | 1 | 2 | 3 | 4 | 5 | 6 | 7 | 8 | 9 | 10 |
| Vout (VDC) | 24.24 | 24.48 | 24.72 | 24.96 | 25.2 | 25.44 | 25.68 | 25.92 | 26.16 | 26.4 |
| Rt up (KΩ) | 814.689 | 177.714 | 92.138 | 58.264 | 40.107 | 28.788 | 21.057 | 15.440 | 11.176 | 7.827 |

NOTE: 1. Datasheets are updated as needed and as such, specifications are subject to change without notice. Once printed or downloaded, datasheets are no longer controlled by Aimtec; refer to www.aimtec.com for the most current product specifications. 2. Product labels shown, including safety agency certifications on labels, may vary based on the date manufactured. 3. Mechanical drawings and specifications are for reference only. 4. All specifications are measured at an ambient temperature of 25°C, humidity<75%, nominal input voltage and at rated output load unless otherwise specified. 5. Aimtec may not have conducted destructive testing or chemical analysis on all internal components and chemicals at the time of publishing this document. CAS numbers and other limited information are considered proprietary and may not be available for release. 6. This product is not designed for use in critical life support systems, equipment used in hazardous environments, nuclear control systems or other such applications which necessitate specific safety and regulatory standards other the ones listed in this datasheet. 7. Warranty is in accordance with Aimtec's standard Terms of Sale available at www.aimtec.com.

X-ON Electronics

Largest Supplier of Electrical and Electronic Components

Click to view similar products for [Isolated DC/DC Converters](#) category:

Click to view products by [Aimtec](#) manufacturer:

Other Similar products are found below :

[ESM6D044440C05AAQ](#) [FMD15.24G](#) [PSL486-7LR](#) [Q48T30020-NBB0](#) [18362](#) [JAHW100Y1](#) [SPB05C-12](#) [SQ24S15033-PS0S](#) [19-130041](#)
[CE-1003](#) [GQ2541-7R](#) [RDS180245](#) [MAU228](#) [J80-0041NL](#) [DFC15U48D15](#) [XGS-0512](#) [XGS-1205](#) [XGS-1212](#) [XGS-2412](#) [XGS-2415](#) [XKS-](#)
[1215](#) [06322](#) [NCT1000N040R050B](#) [SPB05B-15](#) [SPB05C-15](#) [L-DA20](#) [DCG40-5G](#) [QME48T40033-PGB0](#) [XKS-2415](#) [XKS-2412](#) [XKS-1212](#)
[XKS-1205](#) [XKS-0515](#) [XKS-0505](#) [XGS-2405](#) [XGS-1215](#) [XGS-0515](#) [73-551-5038I](#) [AK1601-9RT](#) [VI-N61-CM](#) [VI-R5022-EXWW](#) [PSC128-](#)
[7iR](#) [RPS8-350ATX-XE](#) [DAS1004812](#) [PQA30-D24-S24-DH](#) [VI-M5F-CQ](#) [VI-LN2-EW](#) [VI-PJW01-CZY](#) [CK2540-9ERT](#) [AK-1615-7R](#)