

成品订购码

PC 6 01 □ □

① ② ③ ④ ⑤

①规格代号	②接管口径	③连接螺纹		④颜色代号		⑤牙型代号
PC: 螺纹直通 	4: $\Phi 4$ mm 6: $\Phi 6$ mm 8: $\Phi 8$ mm 10: $\Phi 10$ mm 12: $\Phi 12$ mm	连接螺纹 M5: M5X0.8	适用接管口径 $\Phi 4, \Phi 6$	颜色代号 空白: 灰色 D: 黑色	颜色定义 接口: 灰色 接口: 黑色	空白: PT牙
POC: 圆螺纹直通 		01: PT1/8 02: PT1/4 03: PT3/8 04: PT1/2	$\Phi 4, \Phi 6$ $\Phi 8, \Phi 10$ $\Phi 12$			

产品规格

使用压力范围	0~10kgf/cm ² (0~1.0MPa)
负压	-750mmHg(10Torr)
保证耐压力	1.5MPa
使用温度范围(°C)	-20~70
适用软管	尼龙软管或PU管
颜色	灰色/黑色

接口端螺纹与插管端内径配置表

产品系列	螺纹规格	插管口径				
		$\Phi 4$	$\Phi 6$	$\Phi 8$	$\Phi 10$	$\Phi 12$
PC	M5	●	●			
	PT1/8	●	●	●	●	●
	PT1/4	●	●	●	●	●
	PT3/8		●	●	●	●
	PT1/2		●	●	●	●
POC	M5	●	●			
	PT1/8	●	●	●	●	
	PT1/4	●	●	●	●	●
	PT3/8			●	●	●
	PT1/2			●	●	●

产品特性

1、外观小巧，节省安装空间，性价比高；

2、螺纹部分涂有密封剂，M5公制

螺纹附密封垫片，确保螺纹连

接部份无泄漏；

3、塑胶接口部份颜色有灰色与黑色可选，

方便您整体配管需求。

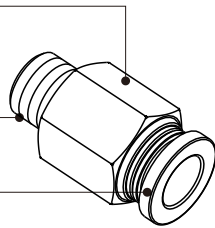

内部结构

PC系列

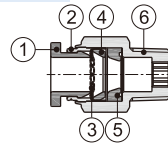

序号	名称	材质	序号	名称	材质
1	塑胶接口	POM	4	定位座	POM
2	定位环	铝合金	5	异型O令	NBR
3	弹簧垫片	不锈钢	6	本体	黄铜

外部规格

PC系列

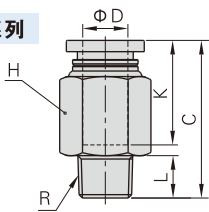

型号\符号	ΦD	R	L	C	K	对边H	重量(g)
PC4M5	4	M5×0.8	3.5	19.5	14	9	6.5
PC401		PT1/8	7.5	19.5	14	10	7
PC402		PT1/4	10	19.5	14	14	13.5
PC6M5	6	M5×0.8	3.5	22.5	16.5	12	8.5
PC601		PT1/8	7.5	22.0	18.5	12	7.5
PC602		PT1/4	10	24.5	18.5	14	15.5
PC603		PT3/8	11	22.5	18.5	17	24
PC604		PT1/2	14	26.0	18.5	21	46
PC801	8	PT1/8	7.5	28	18.5	14	13.5
PC802		PT1/4	10	27	18.5	14	13
PC803		PT3/8	11	23.5	18.5	17	21
PC804		PT1/2	14	27	18.5	21	43.5
PC1001	10	PT1/8	7.5	30	21	17	20.5
PC1002		PT1/4	10	32.5	21	17	24
PC1003		PT3/8	11	28	21	17	20.5
PC1004		PT1/2	14	26.5	21	21	36
PC1201	12	PT1/8	7.5	32.5	23	21	38.5
PC1202		PT1/4	10	35	23	21	40.5
PC1203		PT3/8	11	30.5	23	21	28.5
PC1204		PT1/2	14	32.5	23	21	41.5

POC系列

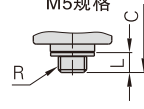
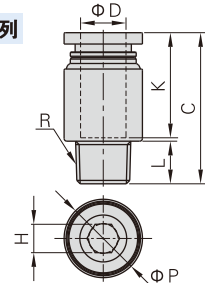

型号\符号	ΦD	R	ΦP	L	C	K	对边H	重量(g)
POC4M5	4	M5×0.8	9	3.5	18.5	14	2.5	3.6
POC401		PT1/8	10	7.5	18	14	3	5.5
POC402		PT1/4	14	10	19.5	14	3	12.6
POC6M5	6	M5×0.8	12	3.5	21.5	16.5	2	5.9
POC601		PT1/8	12	7.5	22.0	18.5	4	6.3
POC602		PT1/4	14	10	22.0	18.5	4	11.8
POC801	8	PT1/8	14	7.5	26.5	18	5	9.9
POC802		PT1/4	14	10	25	18	6	10.1
POC803		PT3/8	17	11	23.5	18	6	19.3
POC1001	10	PT1/8	17	7.5	30	21	5	16.5
POC1002		PT1/4	17	10	29	21	6	15.4
POC1003		PT3/8	17	11	28	21	8	18.7
POC1004		PT1/2	21	14	26.5	21	8	35.3
POC1202	12	PT1/4	21	10	34.5	23	6	32.3
POC1203		PT3/8	21	11	30	23	8	25.1
POC1204		PT1/2	21	14	32	23	8	37.5

成品订购码

PC 6 01 □ □ - M

① ② ③ ④ ⑤ ⑥

①规格代号	②接管口径	③连接螺纹		④颜色代号		⑤牙型代号	⑥类型代号
PC: 螺纹直通 	3.2: $\Phi 3.2\text{mm}$ 4: $\Phi 4\text{mm}$ 6: $\Phi 6\text{mm}$	连接螺纹	适用接管口径	颜色代号	颜色定义	空白: PT牙	M: 迷你型
PL: L型螺纹三通 		M3: M3X0.5	$\Phi 3.2, \Phi 4$	空白: 灰色	接口: 灰色		
		M5: M5X0.8	$\Phi 3.2, \Phi 4, \Phi 6$	D: 黑色	接口: 黑色		
		O1: PT1/8	$\Phi 4, \Phi 6$				

产品规格

使用压力范围	0~10kgf/cm ² (0~1.0MPa)
负压	-750mmHg(10Torr)
保证耐压力	1.5MPa
使用温度范围(°C)	-20~70
适用软管	尼龙软管或PU管
颜色	灰色/黑色

接口端螺纹与插管端内径配置表

产品系列	螺纹规格	插管口径		
		$\Phi 3.2$	$\Phi 4$	$\Phi 6$
PC/PL	M3	●	●	
	M5	●	●	●
	PT1/8		●	●

产品特性

- 六角边车外圆, 减少安装空间;
- 螺纹部分涂有密封剂, M3/M5公制
螺纹附密封垫片, 确保螺纹连接部份无泄漏;
- 塑胶接口椭圆形, 便于狭窄空间使用,
颜色有灰色与黑色可选, 方便整体配管使用。

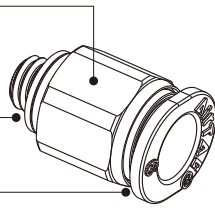

外部规格

PC系列

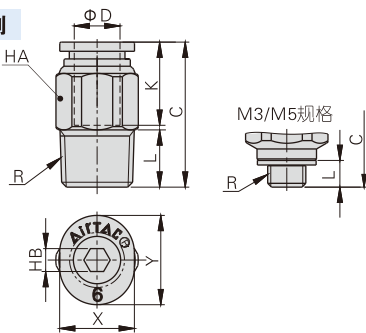

PL系列

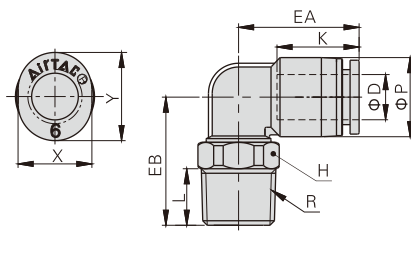

型号\符号	ΦD	R	L	C	K	X	Y	对边HA	对边HB	重量(g)
PC3.2M3-M	3.2	M3×0.5	3	16	11.5	6.8	8.7	7	1.5	1.7
PC3.2M5-M		M5×0.8	3.5	16	11.5	6.8	8.7	7	2	2.0
PC4M3-M	4	M3×0.5	3	17.5	12.5	7.8	9.5	8	1.5	2.4
PC4M5-M		M5×0.8	3.5	17	12.5	7.8	9.5	8	2	2.7
PC401-M		PT1/8	7.5	17.5	13.5	7.8	9.5	10	3	5.5
PC6M5-M	6	M5X0.8	3.5	18.5	13.5	9.8	11.7	10	2	3.6
PC601-M		PT1/8	7.5	19.0	15.5	9.8	11.7	11	4	6.0

型号\符号	ΦD	R	ΦP	L	K	EA	EB	对边H	X	Y	重量(g)
PL3.2M3-M	3.2	M3×0.5	7.5	3	12	14.5	14	7	6.8	8.7	2.4
PL3.2M5-M		M5×0.8		3.5	12						
PL4M3-M	4	M3×0.5	8.5	3	12.5	15	14	7	7.8	9.5	3.0
PL4M5-M		M5×0.8		3.5	12.5						
PL401-M		PT1/8	7.5	12.5	16	10	7.8	9.5	6.2		
PL6M5-M	6	M5X0.8	10.5	3.5	13.5	16.0	15.5	7	9.8	11.7	4.0
PL601-M		PT1/8		7.5	13.5						

成品订购码

同径类接头

PL 6 01 □ □
① ② ③ ④ ⑤

① 规格代号	② 接管口径	③ 连接螺纹	④ 颜色代号	⑤ 牙型代号
PHW: F型螺纹可旋三通 	PL: L型螺纹二通 	连接螺纹 适用接管口径	颜色代号 颜色定义	适用规格
PHF: 串联肘节 	PLL: L型加长螺纹二通 	M5: M5X0.8 Φ4, Φ6	空白: 灰色 接口: 灰色 本体: 灰色	PCF PMF
PEB: T型正螺纹三通 	PLF: L型内螺纹二通 	4: Φ4mm 6: Φ6mm 8: Φ8mm 10: Φ10mm 12: Φ12mm	空白: 灰色 接口: 灰色 本体: 灰色	其它
PED: T型侧螺纹三通 	PCF: 内螺纹直通 	01: PT1/8 02: PT1/4 03: PT3/8 04: PT1/2	D: 黑色 接口: 黑色 本体: 黑色	空白: PT牙 PCF PMF
PYB: Y型螺纹三通 	PMF: 内牙穿板直通 			
PZB: 十字螺纹四通 	PH: 外六角肘节 			

变径类接头:

PKD 6-4 01 □ □
① ② ③ ④ ⑤ ⑥

① 规格代号	② 接管口径	③ 接管口径	④ 连接螺纹	⑤ 颜色代号	⑥ 牙型代号	
PKD: 减径螺纹五通 	6: Φ6mm 8: Φ8mm 10: Φ10mm	4: Φ4mm 6: Φ6mm 8: Φ8mm	01: PT1/8 02: PT1/4 03: PT3/8	颜色代号 颜色定义 空白: 灰色 D: 黑色	接口: 灰色 本体: 灰色 接口: 黑色 本体: 黑色	空白: PT牙

产品规格

使用压力范围	0~10kgf/cm ² (0~1.0MPa)
负压	-750mmHg(10Torr)
保证耐压力	1.5MPa
使用温度范围(°C)	-20~70
适用软管	尼龙软管或PU管
颜色	灰色/黑色

产品特性

- 具有多种型号规格, 广泛应用于各类气动系统;
- 流通性能优越, 可通过与气管内径同容量之流量;
- 拔插接管简单方便快捷, 与气管连接部份安全可靠又耐用;
- 螺纹部分涂有密封胶, M5公制螺纹附密封垫片, 确保螺纹连接部份无泄漏;
- 镀镍的铜体可以防腐蚀和污染, 应用范围更宽广。

内部结构

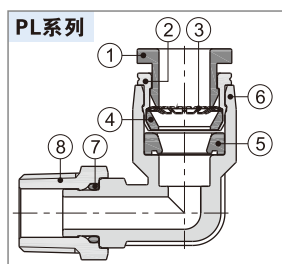

序号	名称	材质
1	塑胶接口	POM
2	定位环	铝合金
3	弹簧垫片	不锈钢
4	定位座	POM
5	异型O令	NBR
6	本体	PBT
7	O型环	NBR
8	转换接头	黄铜

接口端螺纹与插管端内径配置表

产品系列	螺纹规格	插管口径				
		Φ4	Φ6	Φ8	Φ10	Φ12
PL	M5	●	●			
	PT1/8	●	●	●	●	●
	PT1/4	●	●	●	●	●
	PT3/8		●	●	●	●
	PT1/2		●	●	●	●
PLL	M5	●	●			
	PT1/8	●	●	●	●	
	PT1/4	●	●	●	●	●
	PT3/8		●	●	●	●
	PT1/2		●	●	●	●
PEB PED PYB	M5	●	●			
	PT1/8	●	●	●	●	
	PT1/4	●	●	●	●	●
	PT3/8		●	●	●	●
	PT1/2		●	●	●	●
PH PHF	M5	●	●			
	PT1/8	●	●	●		
	PT1/4		●	●	●	
	PT3/8		●	●	●	●
	PT1/2		●	●	●	●
PHW	PT1/8	●	●	●	●	
	PT1/4		●	●	●	●
	PT3/8		●	●	●	●
	PT1/2		●	●	●	●
	PT1/8		●	●	●	●
PZB	PT1/8		●	●	●	
	PT1/4		●	●	●	●
	PT3/8		●	●	●	●
	PT1/2		●	●	●	●
	PT1/8		●	●	●	●

产品系列	螺纹规格	插管口径				
		Φ4	Φ6	Φ8	Φ10	Φ12
PLF	M5	●	●			
	PT1/8	●	●	●	●	
	PT1/4	●	●	●	●	●
	PT3/8		●	●	●	●
	PT1/2		●	●	●	●
PCF	M5	●	●			
	PT1/8	●	●	●	●	
	PT1/4	●	●	●	●	●
	PT3/8		●	●	●	●
	PT1/2		●	●	●	●
PMF	M5	●	●			
	PT1/8	●	●	●	●	
	PT1/4	●	●	●	●	●
	PT3/8		●	●	●	●
	PT1/2		●	●	●	●
PKD	PT1/8	●				
	PT1/4		●			
	PT3/8			●		

插管—螺纹类

外部规格

PL系列

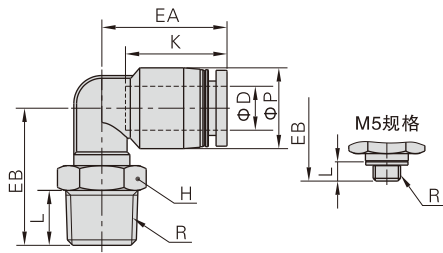

型号\符号	ΦD	R	ΦP	L	K	EA	EB	对边H	重量(g)
PL4M5	4	M5×0.8	9	3.5	14	17	15	8	3
PL401		PT1/8	9	7.5	14	17	18.5	10	4.5
PL402		PT1/4	9	10	14	17	22.0	14	12
PL6M5	6	M5×0.8	12.5	3.5	17	20	17.0	8	4.5
PL601		PT1/8	12.5	7.5	17	20	20.5	10	6
PL602		PT1/4	12.5	10	17	20	24.0	14	13.5
PL603		PT3/8	12.5	11	17	20	25.5	17	20.5
PL604	PT1/2	12.5	14	17	20	30.0	21	36	
PL801	8	PT1/8	15	7.5	18.5	23	20.5	10	7.5
PL802		PT1/4	15	10	18.5	23	25.0	14	13
PL803		PT3/8	15	11	18.5	23	26.5	17	21
PL804		PT1/2	15	14	18.5	23	31.0	21	36
PL1001	10	PT1/8	18	7.5	21	25.5	25.0	17	16.5
PL1002		PT1/4	18	10	21	25.5	27.0	17	19
PL1003		PT3/8	18	11	21	25.5	28.0	17	21
PL1004		PT1/2	18	14	21	25.5	32.5	21	37
PL1201	12	PT1/8	21	7.5	23	28.5	26.5	17	19
PL1202		PT1/4	21	10	23	28.5	28.5	17	21.5
PL1203		PT3/8	21	11	23	29.5	33	17	25.5
PL1204		PT1/2	21	14	23	29.5	34	21	37

PCF系列

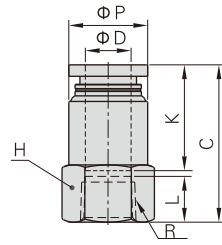

型号\符号	ΦD	R	ΦP	L	C	K	对边H	重量(g)
PCF4M5	4	M5×0.8	9	5	21	14	10	2.7
PCF401		PT1/8	9.5	8	23	14	14	4.5
PCF402		PT1/4	9.5	11	26	14	17	6.5
PCF6M5	6	M5×0.8	12	5	21.5	16.5	12	3.9
PCF601		PT1/8	12.5	8	25.5	16.5	14	5.6
PCF602		PT1/4	12.5	11	28.5	16.5	17	7.5
PCF603		PT3/8	13	12	29.5	16.5	21	10.7
PCF604	PT1/2	13	13.5	31.0	16.5	25	13.8	
PCF801	8	PT1/8	14	8	27.5	18.5	14	5.8
PCF802		PT1/4	14.5	11	30.5	18.5	17	8.4
PCF803		PT3/8	14.5	12	31.5	18.5	21	11.2
PCF804		PT1/2	14.5	13.5	33	18.5	25	14.4
PCF1001	10	PT1/8	17	8	29	21	17	9.5
PCF1002		PT1/4	17	11	33	21	17	9.9
PCF1003		PT3/8	18	12	34	21	21	14
PCF1004		PT1/2	18	13.5	35.5	21	25	17.1
PCF1202	12	PT1/4	21	11	33.5	23	21	17.5
PCF1203		PT3/8	21	12	35.5	23	21	16.6
PCF1204		PT1/2	21	13.5	37	23	25	19.7

PMF系列

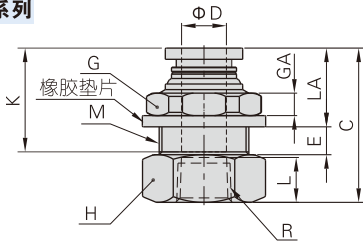

型号\符号	ΦD	R	M	L	C	K	LA	E	GA	对边G	对边H	重量(g)
PMF401	4	PT1/8	M12X1	8	25	14	12	4	4	14	14	6.4
PMF402		PT1/4	M12X1	11	29	14	12	4	4	14	17	9
PMF601	6	PT1/8	M14X1	8	25.5	16.5	12.5	5	4	17	17	9.1
PMF602		PT1/4	M14X1	11	30.5	16.5	12.5	5	4	17	17	10.9
PMF603	8	PT3/8	M14X1	12	31.5	16.5	12.5	5	4	17	21	13.2
PMF801		PT1/8	M16X1	8	27.5	18.5	13.5	5.5	4	19	19	12.8
PMF802	8	PT1/4	M16X1	11	32	18.5	13.5	5.5	4	19	19	15.7
PMF803		PT3/8	M16X1	12	33	18.5	13.5	5.5	4	19	21	15
PMF804	8	PT1/2	M16X1	13.5	34.5	18.5	13.5	5.5	4	19	25	18.1
PMF1001		PT1/8	M20X1	8	30	21	14.5	7.5	5	24	22	19.6
PMF1002	10	PT1/4	M20X1	11	35	21	14.5	7.5	5	24	22	22.8
PMF1003		PT3/8	M20X1	12	36	21	14.5	7.5	5	24	22	21.1
PMF1004	10	PT1/2	M20X1	13.5	37.5	21	14.5	7.5	5	24	25	23.2
PMF1202		PT1/4	M22X1	11	34.5	23	15.5	8	6	27	24	26.2
PMF1203	12	PT3/8	M22X1	12	37.5	23	15.5	8	6	27	24	27
PMF1204		PT1/2	M22X1	13.5	39	23	15.5	8	6	27	25	26.2

PLF系列

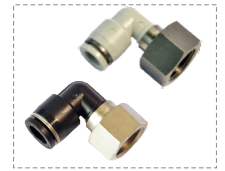
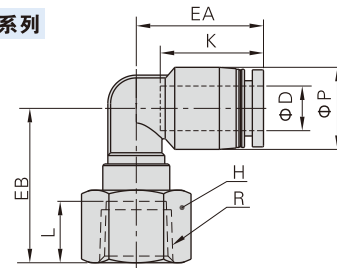

型号\符号	ΦD	R	ΦP	L	K	EA	EB	对边H	重量(g)
PLF4M5	4	M5×0.8	9	5	14	17	16	10	2.9
PLF401		PT1/8	9	8	14	17	21	14	4.6
PLF402		PT1/4	9	11	14	17	24	17	6.8
PLF6M5	6	M5×0.8	12.5	5	17	20	18.5	10	7
PLF601		PT1/8	12.5	8	17	20	23	14	5.8
PLF602		PT1/4	12.5	11	17	20	26	17	8
PLF603		PT3/8	12.5	12	17	20	27	21	10.7
PLF801	8	PT1/8	15	8	18.5	23	20	14	6.6
PLF802		PT1/4	15	11	18.5	23	27.5	17	9.2
PLF803		PT3/8	15	12	18.5	23	28.5	21	11.9
PLF804		PT1/2	15	13.5	18.5	23	30	25	15.2
PLF1001	10	PT1/8	18	8	21	25.5	24	17	11.3
PLF1002		PT1/4	18	11	21	25.5	26.5	17	11.2
PLF1003		PT3/8	18	12	21	25.5	30	21	14.5
PLF1004		PT1/2	18	13.5	21	25.5	31.5	25	17.4
PLF1202	12	PT1/4	21	11	23	28.5	28.5	17	13.7
PLF1203		PT3/8	21	12	23	29.5	32	21	17.4
PLF1204		PT1/2	21	13.5	23	29.5	33	25	20.4

辅助元件——管接头

插管—螺纹类

PLL系列

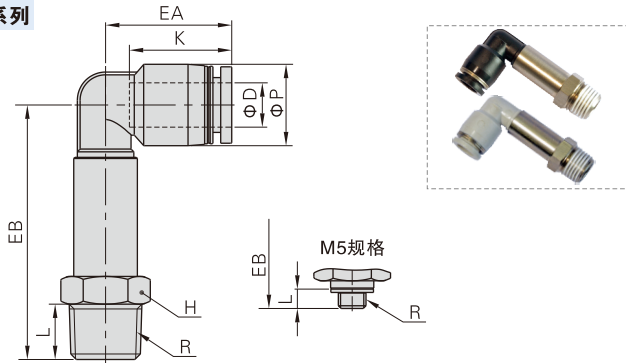

型号\符号	ΦD	R	ΦP	L	K	EA	EB	对边H	重量(g)
PLL4M5	4	M5×0.8	9	3.5	14	17	32.5	8	8.9
PLL401		PT1/8	9	7.5	14	17	35.5	10	12.3
PLL402		PT1/4	9	10	14	17	38.5	14	16.9
PLL6M5	6	M5×0.8	12.5	3.5	17	20	34.5	8	9.9
PLL601		PT1/8	12.5	7.5	17	20	37.5	10	13
PLL602		PT1/4	12.5	10	17	20	40.5	14	18
PLL603	6	PT3/8	12.5	11	17	20	43	17	23.4
PLL801		PT1/8	15	7.5	18.5	23	43.5	12	16.6
PLL802		PT1/4	15	10	18.5	23	45.5	14	22.7
PLL803	8	PT3/8	15	11	18.5	23	48	17	27.7
PLL1001		PT1/8	18	7.5	21	25.5	50.5	15	37.5
PLL1002		PT1/4	18	10	21	25.5	53.5	15	40.6
PLL1003	10	PT3/8	18	11	21	25.5	54.5	17	40.7
PLL1004		PT1/2	18	14	21	25.5	59	21	47.4
PLL1202		PT1/4	21	10	23	28.5	55.5	15	43
PLL1203	12	PT3/8	21	11	23	29.5	60	17	55.4
PLL1204		PT1/2	21	14	23	29.5	63	21	56.7

PHW系列

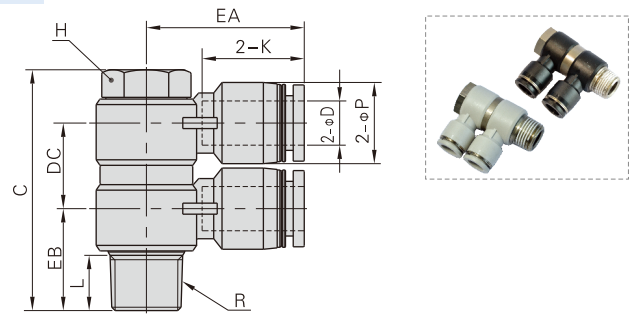

型号\符号	ΦD	R	ΦP	L	C	K	EA	EB	DC	对边H	重量(g)
PHW401	4	PT1/8	9	7.5	38	14	20.5	14.5	13	11	19
PHW601		PT1/8	12.5	7.5	38	16.5	23.0	15	13	11	21
PHW602	6	PT1/4	12.5	10	43.5	16.5	25.0	17.5	15.5	14	40.2
PHW603		PT3/8	12.5	11	50	16.5	27.0	20	16.5	19	69.2
PHW801	8	PT1/8	15	7.5	40.5	18.5	26.5	16.5	15.5	11	23.6
PHW802		PT1/4	15	10	43.5	18.5	28.5	18.5	15.5	14	40.8
PHW803		PT3/8	15	11	50	18.5	29.5	20	16.5	19	70.4
PHW804		PT1/2	15	14	61	18.5	32	24.5	22	24	134.8
PHW1002	10	PT1/4	18	10	46.5	21	31	20	18.5	14	47
PHW1003		PT3/8	18	11	55	21	33	21	22	19	87.5
PHW1004	10	PT1/2	18	14	61	21	35.5	25	22	24	137.7
PHW1203		PT3/8	21	11	55	23	36	23	22	19	86.4
PHW1204	12	PT1/2	21	14	61	23	38	26.5	22	24	147.5

PH系列

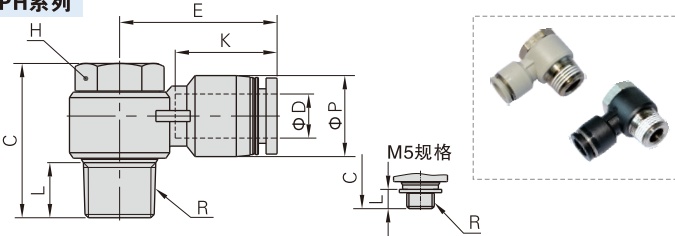

型号\符号	ΦD	R	ΦP	L	C	K	E	对边H	重量(g)
PH4M5	4	M5×0.8	9	3.5	17	14	19	8	5.8
PH401		PT1/8	9	7.5	25	14	20.5	11	12.8
PH6M5	6	M5×0.8	12.5	3.5	17	16.5	23.5	8	6.8
PH601		PT1/8	12.5	7.5	25	16.5	23	11	14
PH602	6	PT1/4	12.5	10	28	16.5	25	14	25.4
PH603		PT3/8	12.5	11	33	16.5	27	19	50.2
PH801	8	PT1/8	15	7.5	25	18.5	26.5	11	14.7
PH802		PT1/4	15	10	28	18.5	28.5	14	26.4
PH803		PT3/8	15	11	33	18.5	29.5	19	49.4
PH804		PT1/2	15	14	39	18.5	32	24	89
PH1002	10	PT1/4	18	10	28	21	31	14	27.7
PH1003		PT3/8	18	11	33	21	33	19	51.1
PH1004	10	PT1/2	18	14	39	21	35.5	24	88.5
PH1203		PT3/8	21	11	33	23	36	19	53
PH1204	12	PT1/2	21	14	39	23	38	24	92.8

PHF系列

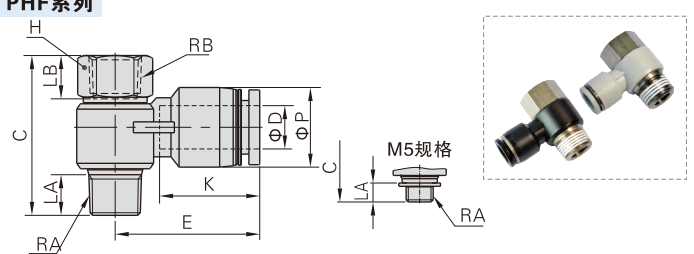

型号\符号	ΦD	RA	RB	ΦP	LA	LB	C	K	E	对边H	重量(g)
PHF4M5	4	M5×0.8	M5×0.8	9	3.5	6	20	14	19	8	6.2
PHF401		PT1/8	PT1/8	9	7.5	8	29.5	14	20.5	12	12.9
PHF6M5	6	M5×0.8	M5×0.8	12.5	3.5	6	20	16.5	23.5	8	7.1
PHF601		PT1/8	PT1/8	12.5	7.5	8	29.5	16.5	23	12	13.9
PHF602	6	PT1/4	PT1/4	12.5	10	11	35	16.5	25	17	30.3
PHF603		PT3/8	PT3/8	12.5	11	12	40	16.5	27	19	44.2
PHF801	8	PT1/8	PT1/8	15	7.5	8	29.5	18.5	26.5	12	15
PHF802		PT1/4	PT1/4	15	10	11	35	18.5	28.5	17	30.7
PHF803		PT3/8	PT3/8	15	11	12	40	18.5	29.5	19	44.8
PHF804		PT1/2	PT1/2	15	14	13.5	47.5	18.5	32	24	84.7
PHF1002	10	PT1/4	PT1/4	18	10	11	35	21	31	17	32
PHF1003		PT3/8	PT3/8	18	11	12	40	21	33	19	46.2
PHF1004	10	PT1/2	PT1/2	18	14	13.5	47.5	21	35.5	24	86.1
PHF1203		PT3/8	PT3/8	21	11	12	40	23	36	19	48.4
PHF1204	12	PT1/2	PT1/2	21	14	13.5	47.5	23	38	24	89.7

PKD系列

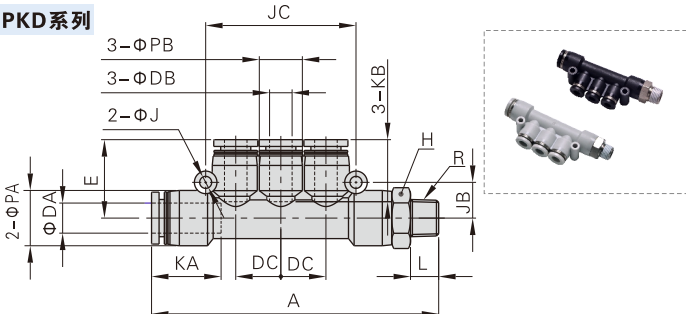

型号\符号	ΦDA	ΦDB	R	L	A	ΦPA	ΦPB	KA
PKD6-401	6	4	PT1/8	7.5	66.5	12.5	9	16.5
PKD8-602	8	6	PT1/4	10	79	15	12.5	18.5
PKD10-803	10	8	PT3/8	11	91.5	18	15	21

型号\符号	KB	ΦJ	JB	JC	DC	E	对边H	重量(g)
PKD6-401	14	3.2	8	34	10	17.5	12	15.8
PKD8-602	16.5	3.2	9.5	40	12	21	14	26.5
PKD10-803	18.5	4.3	11	48	14.5	24	17	38.2

辅助元件——管接头

插管—螺纹类

PEB系列

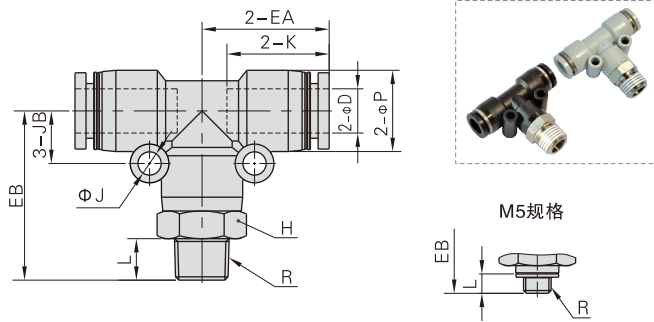

型号\符号	φD	R	φP	L	K	EA	EB	φJ	JB	对边H	重量(g)
PEB4M5	4	M5×0.8	9	3.5	14	17	21	3.2	6.5	9	6.8
PEB401		PT1/8	9	7.5	14	17	25	3.2	6.5	10	8.8
PEB402		PT1/4	9	10	14	17	28	3.2	6.5	14	15.5
PEB6M5	6	M5×0.8	12.5	3.5	16.5	20	23.5	3.2	8	12	11.2
PEB601		PT1/8	12.5	7.5	16.5	20	27.5	3.2	8	12	13.5
PEB602		PT1/4	12.5	10	16.5	20	30.5	3.2	8	14	18.6
PEB603	6	PT3/8	12.5	11	16.5	20	32	3.2	8	17	25.3
PEB801		PT1/8	15	7.5	18.5	23	30.5	4.3	9.5	14	18.4
PEB802		PT1/4	15	10	18.5	23	33	4.3	9.5	14	21.3
PEB803	8	PT3/8	15	11	18.5	23	34.5	4.3	9.5	17	28.2
PEB804		PT1/2	15	14	18.5	23	38.5	4.3	9.5	21	41
PEB1001		PT1/8	18	7.5	21	26.5	34	4.3	11	17	26.7
PEB1002	10	PT1/4	18	10	21	26.5	36.5	4.3	11	17	29.2
PEB1003		PT3/8	18	11	21	26.5	37.5	4.3	11	17	31.9
PEB1004		PT1/2	18	14	21	26.5	41.5	4.3	11	21	45.4
PEB1202	12	PT1/4	21	10	23	30	41	4.3	13	21	49.6
PEB1203		PT3/8	21	11	23	30	42	4.3	13	21	51.2
PEB1204		PT1/2	21	14	23	30	45	4.3	13	21	57.3

PYB系列

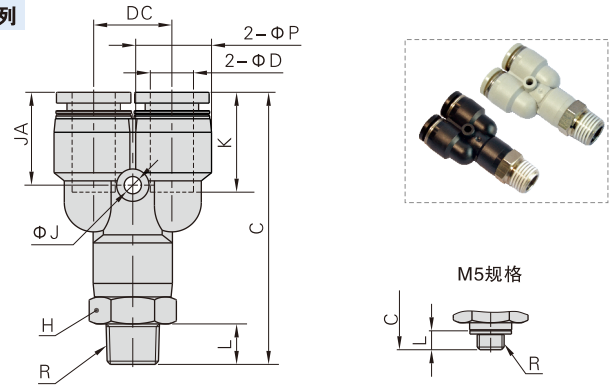

型号\符号	φD	R	φP	L	C	K	φJ	JA	DC	对边H	重量(g)
PYB4M5	4	M5×0.8	9	3.5	35.5	14	3.2	13	10	9	6.7
PYB401		PT1/8	9	7.5	39.5	14	3.2	13	10	10	9
PYB402		PT1/4	9	10	42.5	14	3.2	13	10	14	10.8
PYB6M5	6	M5×0.8	12.5	3.5	40.5	16.5	3.2	15.5	12	12	11.1
PYB601		PT1/8	12.5	7.5	44.5	16.5	3.2	15.5	12	12	13.7
PYB602		PT1/4	12.5	10	47.5	16.5	3.2	15.5	12	14	18.2
PYB603	6	PT3/8	12.5	11	49.0	16.5	3.2	15.5	12	17	25
PYB801		PT1/8	15	7.5	50	18.5	3.2	17	14.5	14	19.8
PYB802		PT1/4	15	10	52.5	18.5	3.2	17	14.5	14	22
PYB803	8	PT3/8	15	11	54	18.5	3.2	17	14.5	17	27.7
PYB804		PT1/2	15	14	58	18.5	3.2	17	14.5	21	40.8
PYB1001		PT1/8	18	7.5	56.5	21	4.3	19.5	18	17	27.4
PYB1002	10	PT1/4	18	10	59	21	4.3	19.5	18	17	29.5
PYB1003		PT3/8	18	11	60	21	4.3	19.5	18	17	32.5
PYB1004		PT1/2	18	14	64	21	4.3	19.5	18	21	45.4
PYB1202	12	PT1/4	21	10	66	23	4.3	21	20.5	21	27.3
PYB1203		PT3/8	21	11	67	23	4.3	21	20.5	21	51.8
PYB1204		PT1/2	21	14	70	23	4.3	21	20.5	21	56.8

PED系列

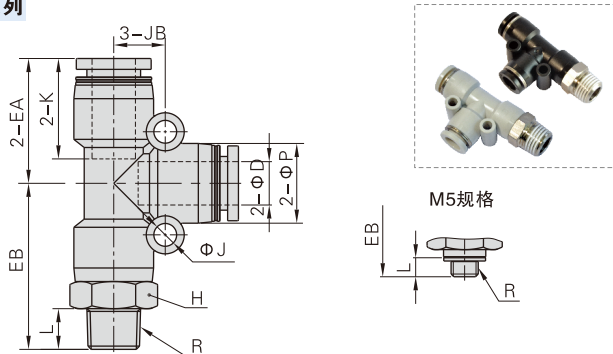

型号\符号	φD	R	φP	L	K	EA	EB	φJ	JB	对边H	重量(g)
PED4M5	4	M5×0.8	9	3.5	14	17	21	3.2	6.5	9	6.8
PED401		PT1/8	9	7.5	14	17	25	3.2	6.5	10	8.8
PED402		PT1/4	9	10	14	17	28	3.2	6.5	14	15.5
PED6M5	6	M5×0.8	12.5	3.5	16.5	20	23.5	3.2	8	12	11.2
PED601		PT1/8	12.5	7.5	16.5	20	27.5	3.2	8	12	13.5
PED602		PT1/4	12.5	10	16.5	20	30.5	3.2	8	14	18.6
PED603	6	PT3/8	12.5	11	16.5	20	32	3.2	8	17	25.3
PED801		PT1/8	15	7.5	18.5	23	30.5	4.3	9.5	14	18.4
PED802		PT1/4	15	10	18.5	23	33	4.3	9.5	14	21.3
PED803	8	PT3/8	15	11	18.5	23	34.5	4.3	9.5	17	28.2
PED804		PT1/2	15	14	18.5	23	38.5	4.3	9.5	21	41
PED1001		PT1/8	18	7.5	21	26.5	34	4.3	11	17	26.7
PED1002	10	PT1/4	18	10	21	26.5	36.5	4.3	11	17	29.2
PED1003		PT3/8	18	11	21	26.5	37.5	4.3	11	17	31.9
PED1004		PT1/2	18	14	21	26.5	41.5	4.3	11	21	45.4
PED1202	12	PT1/4	21	10	23	30	41	4.3	13	21	49.6
PED1203		PT3/8	21	11	23	30	42	4.3	13	21	51.2
PED1204		PT1/2	21	14	23	30	45	4.3	13	21	57.3

PZB系列

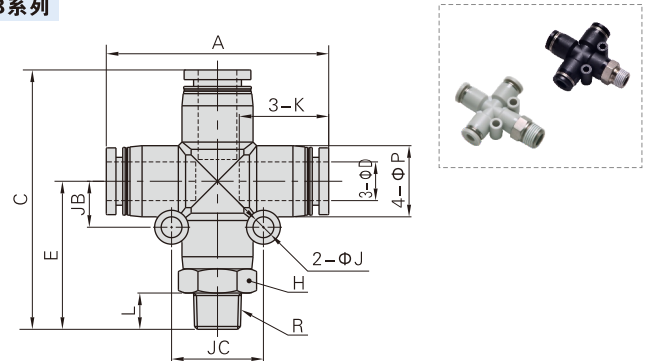

型号\符号	φD	R	L	A	E	C	φP	K	φJ	JB	JC	对边H	重量(g)					
PZB601	6	PT1/8	7.5	27.5	47.5	12.5	16.5	3.2	8	16	12	15.2						
PZB602		PT1/4	10	30.5	50.5						14	20.4						
PZB603		PT3/8	11	32	52						17	27						
PZB801	8	PT1/8	7.5	30.5	53.5	15	18.5	4.3	9.5	19	14	20.9						
PZB802		PT1/4	10	33	56						14	23.8						
PZB803		PT3/8	11	34.5	57.5						17	29.9						
PZB804	8	PT1/2	14	38.5	61.5	21	23	4.3	13	26	21	43.5						
PZB1002		PT1/4	10	36.5	63						17	33.5						
PZB1003		PT3/8	11	52.5	37.5						64	18	21	4.3	11	22	17	36.5
PZB1004	10	PT1/2	14	41.5	68	21	23	4.3	13	26	21	49.2						
PZB1203		PT3/8	11	59.5	42						72	21	23	4.3	13	26	21	56.5
PZB1204		PT1/2	14	45	75						45	75	21	23	4.3	13	26	21

成品订购码

BPC 6 01 □

① ② ③ ④

①规格代号	②接管口径	③连接螺纹	④牙型代号
BPC: 全金属螺纹直通 	4: Φ4mm 6: Φ6mm 8: Φ8mm 10: Φ10mm 12: Φ12mm	M5: M5X0.8 01: PT1/8 02: PT1/4 03: PT3/8 04: PT1/2	空白: PT牙
BPCF: 全金属内螺纹直通 			
BPOC: 全金属圆螺纹直通 			
BPMF: 全金属内牙穿板直通 			

BPM 6

① ②

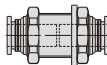
①规格代号	②接管口径
BPM: 全金属穿板直通 	4: Φ4mm 6: Φ6mm 8: Φ8mm 10: Φ10mm 12: Φ12mm

产品规格

使用压力范围	0~9kgf/cm ² (0~0.9MPa)
负压	-750mmHg(10Torr)
保证耐压力	1.5MPa
使用温度范围(°C)	0~150
适用软管	尼龙软管或PU管
颜色	灰色/黑色

[注] 高温场合使用时, 需确认软管或PU管耐温等级。

产品特性

- 属于全金属螺纹类接头, 产品内部部分零件含铜; 有多种型号规格可选, 广泛应用于各类气动系统;
- 流通性能优越, 可通过与气管内径同容量之流量;
- 拔插接管简单方便又快捷, 与气管连接部份安全可靠又耐用;
- 螺纹部分涂密封胶, M5公制螺纹附密封垫片, 确保螺纹连接部份无泄漏;
- 镀镍的金属体可以防腐蚀和污染, 应用范围更宽广;
- 全金属接头适用于高温环境。

接口端螺纹与插管端内径配置表

产品系列	螺纹规格	插管口径				
		Φ4	Φ6	Φ8	Φ10	Φ12
BPC	M5	●	●			
	PT1/8	●	●	●	●	
	PT1/4	●	●	●	●	●
	PT3/8		●	●	●	●
	PT1/2				●	●
BPOC BPCF	M5	●	●			
	PT1/8	●	●	●		
	PT1/4		●	●	●	
	PT3/8				●	●
	PT1/2					●
BPMF	M5					
	PT1/8	●	●	●		
	PT1/4		●	●	●	
	PT3/8				●	●
	PT1/2					●
产品系列		插管口径				
BPM		Φ4	Φ6	Φ8	Φ10	Φ12
		●	●	●	●	●

内部结构

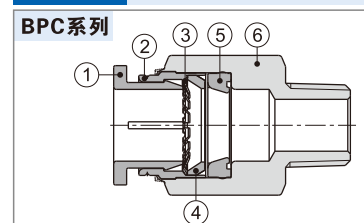

序号	名称	材质
1	金属接口	黄铜
2	定位环	铝合金
3	弹簧垫片	不锈钢
4	定位座	铝合金
5	异型O令	氟橡胶
6	直通接头本体	黄铜

外部规格

BPC系列

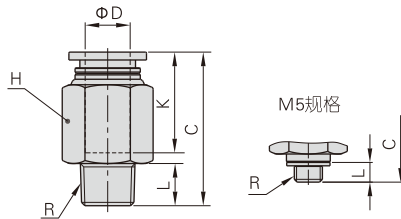

型号\符号	ΦD	R	L	C	K	对边H	重量(g)
BPC4M5	4	M5X0.8	3.5	19.5	14	9	5.5
BPC401		PT1/8	7.5	19.5	14	10	7.9
BPC402		PT1/4	10	19	14	14	8.7
BPC6M5	6	M5X0.8	3.5	22	16	12	10.1
BPC601		PT1/8	7.5	21.5	18	12	14.2
BPC602		PT1/4	10	24	18	14	19.1
BPC603	8	PT3/8	11	22.5	18	17	26.8
BPC801		PT1/8	7.5	27.5	18	14	16.1
BPC802		PT1/4	10	26.5	18	14	16
BPC803	10	PT3/8	11	23	18	17	25.4
BPC1001		PT1/8	7.5	29.5	20.5	17	24.5
BPC1002		PT1/4	10	32	20.5	17	28
BPC1003	12	PT3/8	11	27.5	20.5	17	34.6
BPC1004		PT1/2	14	25.5	20.5	21	39.3
BPC1202		PT1/4	10	34.5	22	21	44.5
BPC1203	12	PT3/8	11	30	22	21	34.2
BPC1204		PT1/2	14	32	22	21	47

BPOC系列

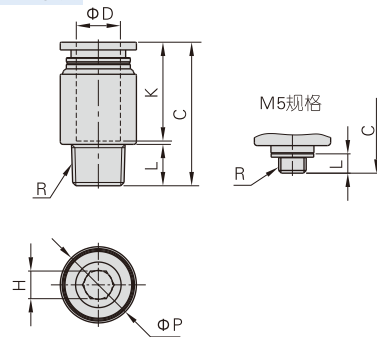

型号\符号	ΦD	R	ΦP	L	C	K	对边H	重量(g)
BPOC4M5	4	M5X0.8	9	3.5	18.5	14	2	4.4
BPOC401		PT1/8	10	7.5	17.5	14	2.5	6.6
BPOC6M5		6	M5X0.8	12	3.5	21	16	2
BPOC601	PT1/8		12	7.5	21.5	18	4	8.4
BPOC602	PT1/4		14	10	21.5	18	4	13.6
BPOC801	8	PT1/8	14	7.5	26	17.5	5	12.3
BPOC802		PT1/4	14	10	24.5	17.5	6	12.7
BPOC1002		PT1/4	17	10	28.5	20.5	6	18.5
BPOC1003	10	PT3/8	17	11	27.5	20.5	8	24.9
BPOC1203		PT3/8	21	11	29.5	22	8	30.4
BPOC1204		PT1/2	21	14	31.5	22	8	42.4

BPCF系列

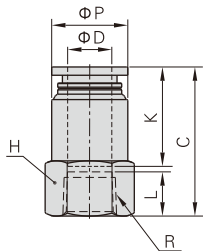

型号\符号	ΦD	R	ΦP	L	C	K	对边H	重量(g)
BPCF4M5	4	M5X0.8	9	5	21	14	10	3.5
BPCF401		PT1/8	9.5	8	23	14	14	5.3
BPCF6M5	6	M5X0.8	12	5	21	16	12	5.6
BPCF601		PT1/8	12.5	8	25	16	14	7.2
BPCF602		PT1/4	12.5	11	28	16	17	9.2
BPCF801	8	PT1/8	14	8	27	18	14	7.1
BPCF802		PT1/4	14.5	11	30	18	17	10.6
BPCF1002	10	PT1/4	17	11	32.5	20.5	17	13.5
BPCF1003		PT3/8	18	12	33.5	20.5	21	17.5
BPCF1203		PT3/8	21	12	35	22	21	22
BPCF1204	12	PT1/2	21	13.5	36.5	22	25	24.9

BPMF系列

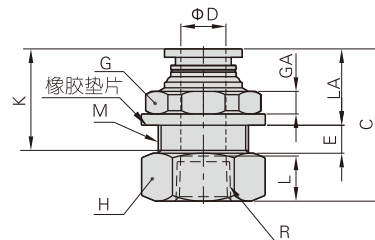

型号\符号	ΦD	R	M	L	C	K	LA	E	GA	对边G	对边H	重量(g)
BPMF401	4	PT1/8	M12X1	8	25	14	12	4	4	14	14	7.6
BPMF601	6	PT1/8	M14X1	8	25	16	12	5	4	17	17	10.4
BPMF602		PT1/4	M14X1	11	30	16	12	5	4	17	17	12.2
BPMF801	8	PT1/8	M16X1	8	27	18	13	5.5	4	19	19	13.9
BPMF802		PT1/4	M16X1	11	31.5	18	13	5.5	4	19	19	15.3
BPMF1002	10	PT1/4	M20X1	11	34.5	20.5	14	7.5	5	24	22	26.2
BPMF1003		PT3/8	M20X1	12	35.5	20.5	14	7.5	5	24	22	24.4
BPMF1203		PT3/8	M22X1	12	37	22	15	8	6	27	24	32.6
BPMF1204	12	PT1/2	M22X1	13.5	38.5	22	15	8	6	27	25	31.8

BPM系列

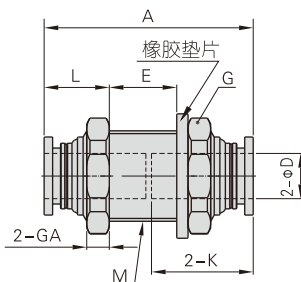

型号\符号	ΦD	M	A	K	L	E	GA	对边G	重量(g)
BPM4	4	M12X1	28.5	14	10	7	4	14	6.4
BPM6	6	M14X1	33	16	10	11	4	17	16.4
BPM8	8	M16X1	37	18	11	13	4	19	15.8
BPM10	10	M20X1	41.5	20.5	12	16	5	24	28.9
BPM12	12	M22X1	45	22	13	17.5	6	27	40.3

X-ON Electronics

Largest Supplier of Electrical and Electronic Components

Click to view similar products for [Other Tools](#) category:

Click to view products by [AIRTAC](#) manufacturer:

Other Similar products are found below :

[899-2-KT46](#) [CR-0AFL4--332K](#) [568681-1](#) [5800-0090](#) [58061-1](#) [59085](#) [00-8273-RDPP](#) [593033](#) [593072](#) [593564100](#) [593575](#) [593593](#) [010-0003-0000](#) [011349-000](#) [CRCW08052740FRT1](#) [LUC-012S070DSM](#) [LUC-018S070DSP](#) [LUC-024S105DSP](#) [599-2021-3-NME](#) [599-JJ-2021-03](#) [CRCW2010331JR02](#) [601-JJ-06](#) [601-SPB](#) [601YSY](#) [602-JJ-03](#) [602SPB](#) [603-JJ-07-FP](#) [603-JJY-04](#) [CRTN1013](#) [CS16](#) [6-1579014-0](#) [62036240-1](#) [M43435 TY 1 SZ 3 FIN B BLK](#) [M43435 TY 2 SZ 3 FIN C BLK](#) [M43435 TY 5 SZ 3 FIN C NAT](#) [M-5Z](#) [M6816](#) [660-29ABT1](#) [662508-1](#) [CVHD-950X-93.333](#) [CW104-01X](#) [671-GP-04-KT39-73207](#) [CW307-01A](#) [CW30901A](#) [CW6211201A](#) [679793-1](#) [690191-1](#) [690191-3](#) [690317-2](#)