



APPROVAL SHEET

Customer Name	:	
Customer P/N	:	
Frequency	:	8.000000 MHz
AKER Approved P/N	:	49M-008000-FX7X11
AKER MPN	:	49M-008000-FX7X11
REVISION	:	A0
ISSUED DATE	:	2023/5/26

APPROVED	CHECKED	PREPARED
<i>Earnest</i>		<i>Kika</i>
APPROVED BY CUSTOMER		

AKER TECHNOLOGY CO., LTD.

ADDRESS : No.11-3, Jianguo Rd., Tanzi Dist., Taichung City 427, Taiwan

TEL : 886-4-25335978

FAX : 886-4-25336011

Web: www.aker.com.tw

RoHS compliant



Customer P/N			
AKER Approved P/N	49M-008000-FX7X11		
APPROVED	Earnest	SHEET	2 OF 6
PREPARED	Kiku	REV.	A0

HC-49US SMD CRYSTAL SPECIFICATION

1 . ELECTRICAL CHARACTERISTICS

(1) Standard atmospheric conditions

Unless otherwise specified , the standard range of atmospheric conditions for making measurement and tests are as follow :

Ambient temperature : $25\pm 5^{\circ}\text{C}$

Relative humidity : 40%~70%

If there is any doubt about the results , measurement shall be made within the following limits :

Ambient temperature : $25\pm 3^{\circ}\text{C}$

Relative humidity : 40%~70%

(2) Measurement Equipment : SAUNDERS 250B (Measured FL)

(3) Cutting Mode : AT CUT

(4) Oscillation Mode : Fundamental

Parameters	Symbol	Electrical Specification				Notes
		Min.	Typ.	Max.	Unit	
Nominal Frequency	FL	8.000000			MHz	
Load Capacitance	CL	12			pF	
Frequency Tolerance		-30	~	30	ppm	At $25^{\circ}\text{C} \pm 3^{\circ}\text{C}$
Frequency Stability		-30	~	30	ppm	Related to 25°C
Drive Level	DL			100	uW	
Operating Temperature Range		-40	~	85	$^{\circ}\text{C}$	
Storage Temperature Range		-55	~	125	$^{\circ}\text{C}$	
Effective Series Resistance	RR			60	Ω	
Shunt Capacitance	C0			7	pF	
Motional Capacitance	C1		N/A		fF	
Ratio Of Capacitance	r		N/A			C0/C1
Aging Rate		-3	~	3	ppm	First Year at 25°C
Insulation Resistance		500			MOhms	At DC 100V

*Please kindly be noted that **AKER DO NOT** guarantee parts quality which involves human security application.*

	Customer P/N			
	AKER Approved P/N	49M-008000-FX7X11		
	APPROVED	Earnest	SHEET	3 OF 6
	PREPARED	Kiku	REV.	A0

2 . MARKING

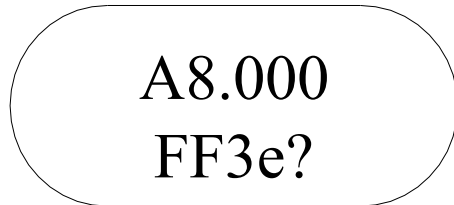

← AKER Logo and Frequency

← Type and Date Code

Type and Date Code

F	F	3	e	?
Oscillation Mode Code	Load Capacitance Code	Frequency Tolerance Code	Date Code	Internal identification code

Oscillation Mode Code

Code	Oscillation Mode
F	AT Cut / Fundamental
T	AT Cut / 3rd Overtone
B	BT Cut / Fundamental

Frquency Tolerance Code

Code	Tolerance	Code	Tolerance
1	±20 ppm	6	±50 ppm
2	±25 ppm	9	±10 ppm
3	±30 ppm	0	±100 ppm
5	±15 ppm		

Load Capacitance Code

Code	CL	Code	CL
S	Series	P	4
A	16	Q	39
B	20	R	12.5
C	30	T	8
D	18	U	33
E	32	V	7
F	12	W	6
G	22	X	17
H	27	Y	8.5
I	10	Z	19.5
J	14	a	21.5
K	15	b	24
L	25	c	35
M	9	d	37
N	13		

Date Code

Year Month	2017	2018	2019	2020
	2021	2022	2023	2024
	2025	2026	2027	2028
	(4N+1)	(4N+2)	(4N+3)	(4N+0)
JAN	A	N	a	n
FEB	B	P	b	p
MAR	C	Q	c	q
APR	D	R	d	r
MAY	E	S	e	s
JUN	F	T	f	t
JUL	G	U	g	u
AUG	H	V	h	v
SEP	J	W	j	w
OCT	K	X	k	x
NOV	L	Y	l	y
DEC	M	Z	m	z

Please kindly be noted that AKER DO NOT guarantee parts quality which involves human security application.



Customer P/N			
AKER Approved P/N	49M-008000-FX7X11		
APPROVED	Earnest	SHEET	4 OF 6
PREPARED	Kiku	REV.	A0

3 . DIMENSIONS : (Unit : mm)

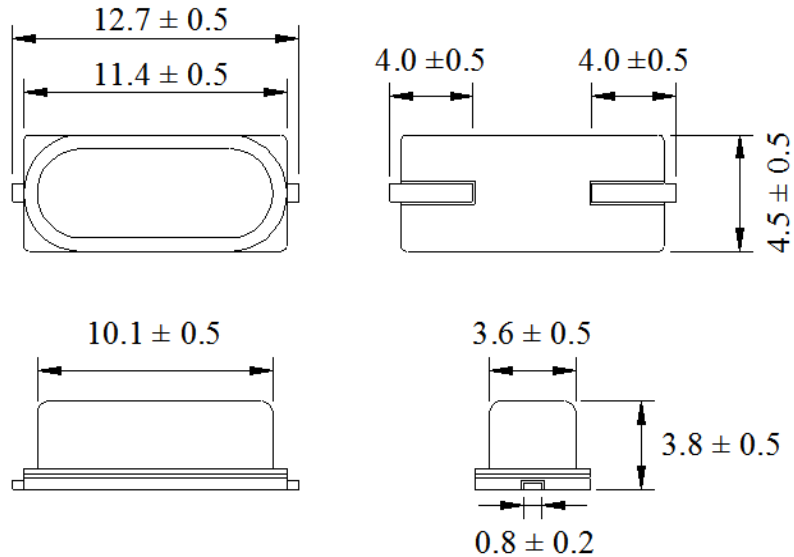

4 . SUGGESTED LAND PATTERN : (Unit : mm)

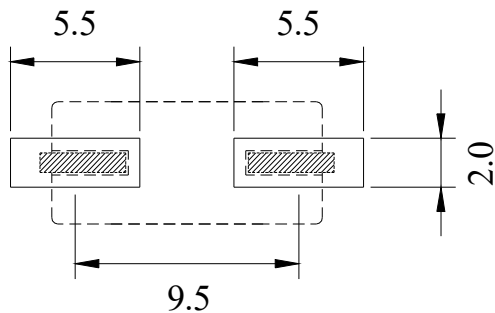

5 . SOLDERING REFLOW PROFILE

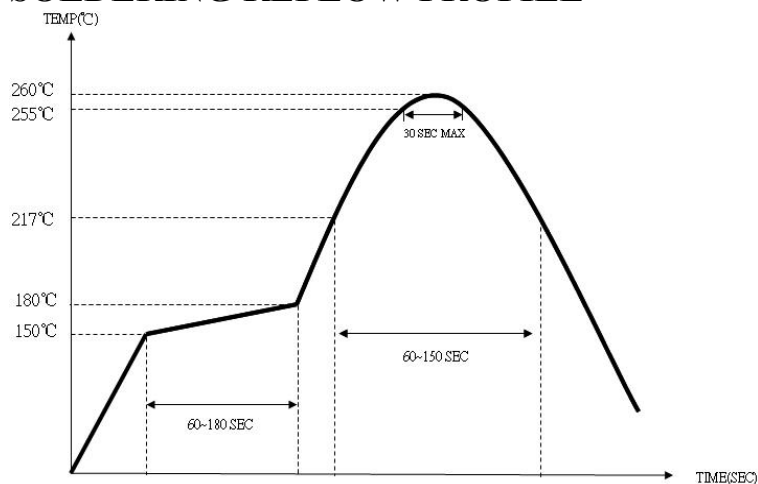

Please kindly be noted that AKER DO NOT guarantee parts quality which involves human security application.



Customer P/N			
AKER Approved P/N	49M-008000-FX7X11		
APPROVED	Earnest	SHEET	5 OF 6
PREPARED	Kiku	REV.	A0

6. PACKING : (Unit : mm) 1000pcs/reel

6.1 TAPE SPECIFICATION

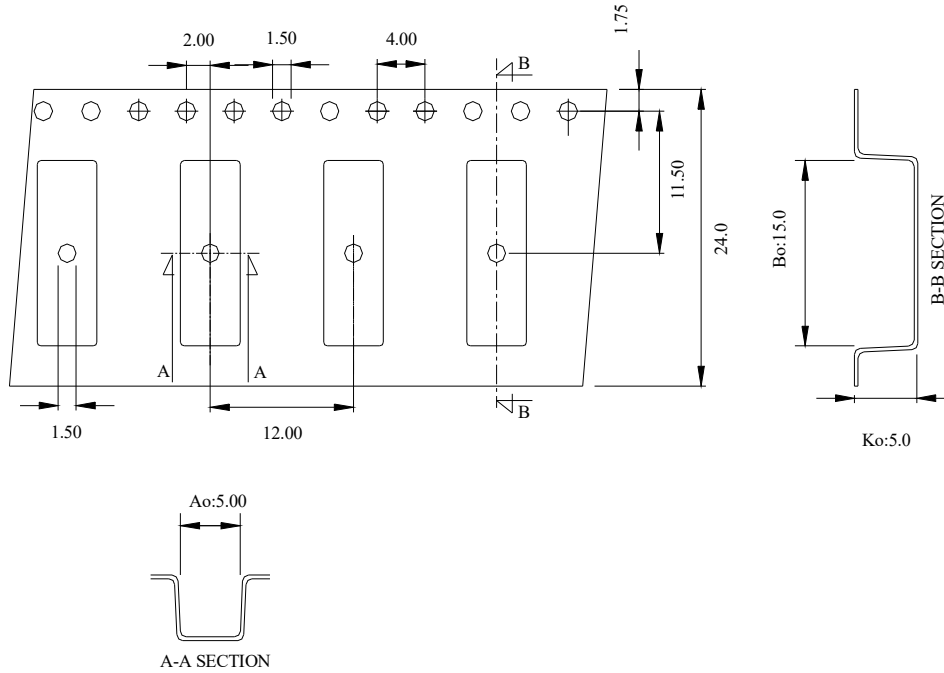

6.2 REEL SPECIFICATION

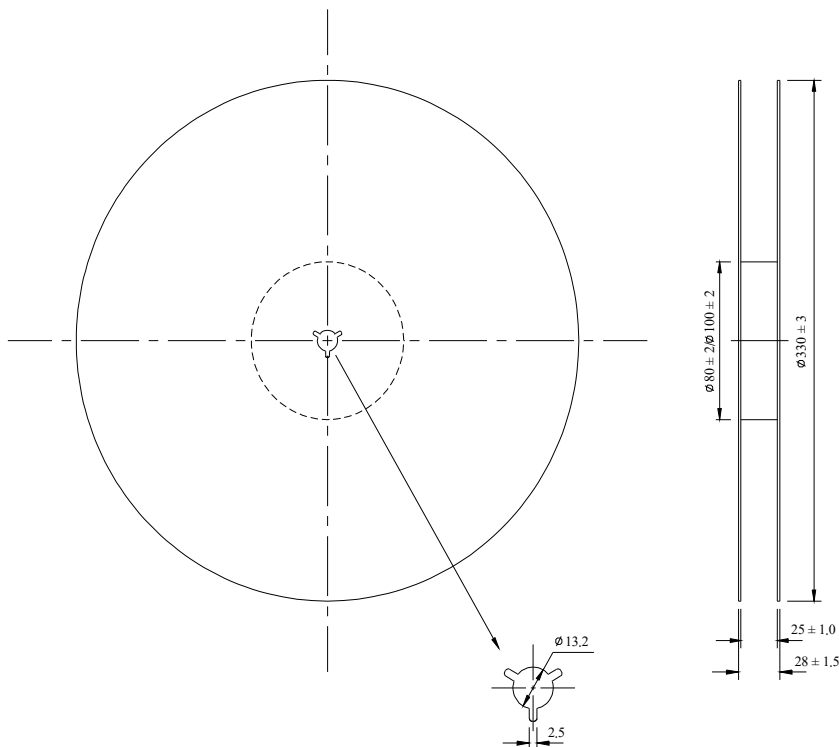

*Please kindly be noted that **AKER DO NOT** guarantee parts quality which involves human security application.*



Customer P/N			
AKER Approved P/N	49M-008000-FX7X11		
APPROVED	Earnest	SHEET	6 OF 6
PREPARED	Kiku	REV.	A0

7 . RELIABILITY SPECIFICATION

No	Test Item	Test Methods	Performance
1	Drop Test	Free drop from 50 cm height onto a hard wooden board for 3 times	To satisfy the electrical characteristics
2	Mechanical Shock	1000 G, 0.5 msec, 3 times for each direction (X, Y, Z)	
3	Vibration	Frequency range : 20 ~ 2000 Hz Amplitude : 1.52 mm / 20G Sweep time : 20 minutes Test time for each direction : 2 Hours (Total 6 Hours)	
4	Gross Leak	Alcohol, Test Pressure : > -40cm-Hg	No bubbles stream
5	Fine Leak	5 kgf /cm ² Helium bombing for 2 Hours	≤10 ⁻⁸ atm.cc./sec
6	Solderability	Temperature : 260°C ± 5°C Immersion time : 5 ± 1 seconds	90% min. coverage of new solder
7	Resistance To Soldering Heat	Solder pot test Test temperature : 260°C ± 5°C Test time : 10 ± 1 seconds	To satisfy the electrical characteristics
8	High Temperature Storage	+ 125 °C ± 3 °C for 500 ± 12 Hours	
9	Low Temperature Storage	- 55 °C ± 3 °C for 500 ± 12 Hours	
10	Temperature Cycle	Total 100 cycles of the following temperature cycle 	
11	High Temperature And Humidity	85°C ± 5°C , RH 85% ± 5%, 500 ± 12 Hours	

X-ON Electronics

Largest Supplier of Electrical and Electronic Components

Click to view similar products for [Crystals](#) category:

Click to view products by [Aker](#) manufacturer:

Other Similar products are found below :

[CX3225GB25000M0PPSZ1](#) [718-13.2-1](#) [7A-40.000MAAE-T](#) [FL2000085](#) [99-BU](#) [9B-15.360MBBK-B](#) [9C-7.680MBBK-T](#) [H10S-12.000-18-EXT-TR](#) [ABC2-6.000MHZ-D4Z-T](#) [ABLS-20.000MHZ-D2-T](#) [ABS071-32.768KHZ-6-T](#) [R38-32.768-12.5-5PPM-NPB](#) [BTD1062E05A-513](#) [21U15A-21.4MHZ](#) [RTX-781DF1-S-20.950](#) [LFXTAL066198Cutt](#) [9C-14.31818MBBK-T](#) [A-11.000MHZ-27](#) [ABL-27.000MHZ-B4Y-T](#) [ABM11-132-24.000MHZ-T3](#) [ABM3B1-25.000MHZ-D2Y-T](#) [SPT2A-.032768B](#) [SPT2A.032768G](#) [LFXTAL065253Cutt](#) [LFXTAL066431Cutt](#) [XT9S20ANA14M7456](#) [XT9SNLANA16M](#) [7A-24.576MBBK-T](#) [7B-30.000MBBK-T](#) [CX2520DB16000H0HPQCC](#) [MMCC2R32.7680KHZ](#) [6504-202-1501](#) [6526-202-1501](#) [ABLS-12.000MHZ-B2Y-T](#) [7A-10.000MBBK-T](#) [SG636PCE-20.000MC](#) [3404](#) [CM315D32768EZFT](#) [C1E-24.000-7-2020-R](#) [C1E-19.200-12-1530-X-R](#) [C1E-16.000-12-1530-X-R](#) [ABM11-16.000MHZ-9-B1U-T](#) [FL5000014](#) [EUCA18-3.1872M](#) [FX0800015](#) [425F35E027M0000](#) [FP0800018](#) [MS3V-T1R-32.768kHz-7pF-20PPM-TA-QC-Au](#) [VXM7-1C1-16M000](#) [MS3V-T1R-32.768kHz-9pF-20PPM-TA-QC-Au](#)