

UPT210

Multi-Function Energy Meter



- Compact 6 DIN Modules Size
- High Contrast LCD Display
- True RMS Measurement
- Active, Reactive and Apparent Energy (4 Counters)
- Neutral Current Measurement
- More than 35 Electrical Parameters Measured and Displayed (ENH Version)
- Optional Power and Current Demand Calculation
- Optional RS485 Communication Port
- Programmable Transformer Ratios
- Two Digital Outputs for Energy Pulsing
- Indication of Phase Sequence and Wrong CT Connection
- Accuracy Class 1 or 2 according to EN62053 (ex EN61036)



General Description

The UPT210 is a programmable multi-function energy meter able to measure the energy consumption and the main electrical parameters on three-phase systems.

It provides accurate measurements even for distorted waveform.

Up to two energies can be re-emitted on the optoisolated outputs.

The high contrast LCD display allows the user to check all the measured values. The working parameters can be easily set up by instrument keypad.

The optional RS485 serial communication port allows to transfer the three phase electrical parameters from the instrument.

The WINTOOL, free of charge software, allows to show on a PC all the measured values and to program the instrument in a fast way.

The UPT210 replaces multiple analog meters as well as single function meters such as voltmeters, ammeters, wattmeters, varmeters, frequency-meters, powerfactor-meters, energy-meters, etc.

The UPT210 is a compact, cost effective multi-function transducer suitable for energy monitoring and electrical network management.

WINTOOL Communication Software
available for free on the Web

Benefits

- The UPT210 basic version provides four energy counters (two quadrants) and the main electrical parameters for a quick and easy check of the load conditions.
- The programmable transformer ratios allow to count and display the primary values.
- A diagnostic function detects the current transformer polarity and the phase sequence in order to indicate on the LCD any connection or installation error.
- It is suitable for conventional meters replacing since it is ultracompact and easy on mounting.
- Via communication port it is possible to read and log on a PC all the readings (more than 35 electrical parameters). The remote connection allow to generate on a PC consumption profiles, logged values trends, cost allocation and reports as well as to identify critic values.

Applications

- Switchboards, gensets, motor control centers, etc.
- Replacement of electromechanical meters for household, industrial and commercial applications
- Power monitoring & control systems
- Individual machine load monitoring
- Capacitor bank operation supervision
- Remote metering and cost allocation

Main Features

Measurements

- Single phase and three-phase 3-wire or 4-wire unbalanced load operation.
- True RMS metering provides accurate measurement even for distorted waveform.
- More than 35 electrical parameters are measured. The basic version displays on the LCD the system values for a quick and easy check of the load conditions. The table on the right shows the measured parameters and the available options.
- Programmable 1A / 5A current full scale allows to fit the standard CTs.
- CT primary value is programmable up to 9999 to show the real energy consumption values.

Front Panel Display

- High contrast LCD display.
- Two keys ensure the selection of the information on the LCD display and the instrument programming.
- Password protected setup and resetting operations.

Communication

- RS485 optoisolated communication port (option).
- MODBUS, STANDARD ASCII or LONBUS protocol on request.
- Communication speed programmable up to 57600 bps (78 kbps in case of LONBUS).

Inputs & Outputs

- Two digital optoisolated outputs for energy pulsing. The pulse value is programmable.

Advanced Diagnostic Functions

- Wrong current transformer polarity and phase sequence connection errors are indicated on the LCD display.
- Over / undervoltage, overcurrent and frequency out of range are detected to indicate the uncorrect working conditions.
- Pulse emission frequency too high or CT too high are checked to indicate programming mistakes.

INSTANTANEOUS MEASUREMENTS		
PHASE VOLTAGE	$V_{L1-N} - V_{L2-N} - V_{L3-N}$ [V]	●
LINE VOLTAGE	$V_{L1-L2} - V_{L2-L3} - V_{L3-L1}$ [V]	●
SYSTEM VOLTAGE	V [V]	●
LINE CURRENT	$I_{L1} - I_{L2} - I_{L3} - I_N$ [A]	■
SYSTEM CURRENT	I [A]	■
POWER FACTOR	$PF_{L1} - PF_{L2} - PF_{L3}$	●
SYSTEM POWER FACTOR	PF	●
APPARENT POWER	$S_{L1} - S_{L2} - S_{L3}$ [VA]	■
SYSTEM APPARENT POWER	S [VA]	■
ACTIVE POWER	$P_{L1} - P_{L2} - P_{L3}$ [W]	■
SYSTEM ACTIVE POWER	P [W]	■
REACTIVE POWER	$Q_{L1} - Q_{L2} - Q_{L3}$ [var]	■
SYSTEM REACTIVE POWER	Q [var]	■
FREQUENCY	f [Hz]	●
DEMAND (AVERAGE VALUES)	$4 \times I_{AVG} - S_{AVG} - P_{AVG}$	○
PHASE REVERSAL	123 / 132	●
STORED DATA		
SYSTEM ACTIVE ENERGY	[Wh]	■
SYSTEM APPARENT ENERGY	[VAh]	■
SYSTEM LAGGING REACTIVE ENERGY	[varh ind]	■
SYSTEM LEADING REACTIVE ENERGY	[varh cap]	■
PEAK VALUES	$3 \times V_{L-N} - 3 \times V_{L-L} - 3 \times I_L - 3 \times I_{AVG} - P_{AVG} - S_{AVG}$	○

● = Standard ○ = Optional ■ = Bi-directional value (BIDIR option only)

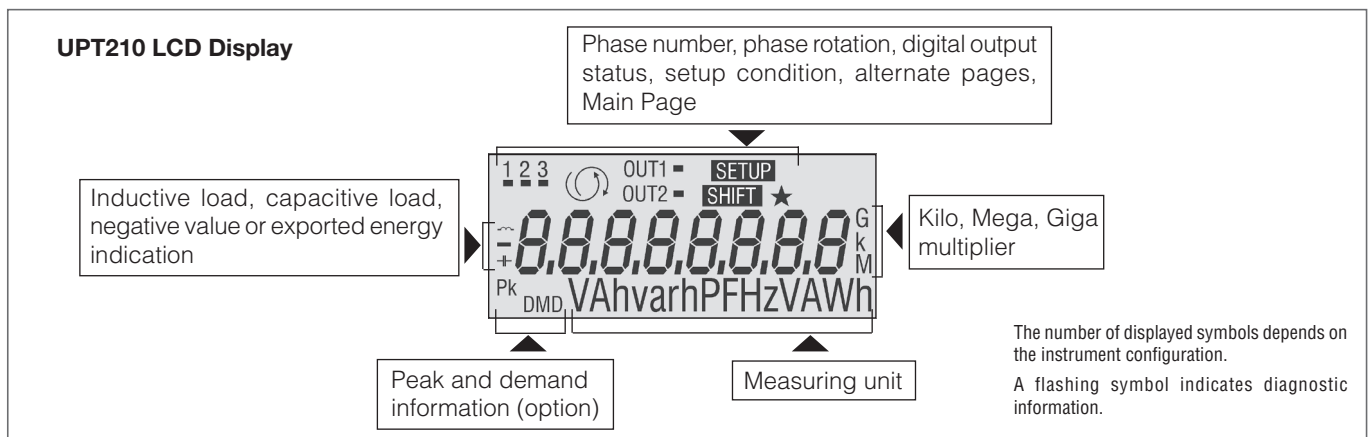

Specifications

Power supply (1)

Rated voltage: powered from measuring inputs (1)
 Consumption: 0,8VA max

Voltage inputs

Rated voltage: A) 3x230/400VAC +15% -20% - 4 wires
 B) 3x120/208VAC +15% -20% - 4 wires
 C) 3x400VAC +15% -20% - 3 wires
 D) 3x208÷230VAC +15% -20% - 3 wires
 E) 3x100÷120VAC +15% -20% - 3 wires
 >1.3 MOhm
 Input impedance: max 0.15 VA per phase
 Burden: 45 - 65 Hz
 Frequency:

Current inputs

Rated current (Ib): 1 / 5 ARMS programmable
 Min / max measurable current: 20 mA / 7 ARMS
 Maximum overload: 10ARMS continuous - 100 ARMS for 1 sec.
 Input impedance: 0.02 Ohm approximately
 Burden: max 0,5 VA per phase
 Insulation voltage: 150 VAc max between phases

Typical accuracy

Voltage: ± 0.3% reading ± 0.05% full scale
 Current: ± 0.5% reading ± 0.05% full scale
 Active power: ± 1% reading ± 0.1% full scale (PF=1)
 Power factor: 1,5% reading (0.5 inductive - 0.8 capacitive)
 Active energy: 1% reading (0.5 inductive - 0.8 capacitive)
 Frequency: ± 0.05% reading ± 2 digits from 45 to 65 Hz

Display and operating controls

Display: high contrast LCD display 43 x 19 mm
 eight digits for energies and other parameters + symbols
 Keypad: 2 push-buttons

Communication port (2)

Type: RS485 on request, optoisolated
 Baud Rate: 300 to 57600 bps
 78 kbps in case of LONBUS
 Protocols: ASCII STANDARD, MODBUS or LONBUS on request

Digital outputs

Type: no.2 optoisolated (50V-100mA_{DC})

Environmental conditions

Operating temperature: from -15°C to +60°C
 Storage temperature: from -25°C to +75°C
 Relative humidity: 80% max. without condensation

Mechanical characteristics

Material: plastic enclosure - noryl UL94-V0
 Protection degree: IP51 (front panel); IP20 (terminals)
 Terminals: conductors 2.5mm²
 Size / Weight: 106x90x57mm, 6 DIN-RAIL modules, 300gr

Standards compliance

Safety: 73/23/EEC and 93/68/EEC directives, EN61010.1 safety standard
 EMC: 89/366/EEC directive and following modifications 93/31/EEC and 93/68/EEC, EN50081-2, EN50082-2, EN61326/A1

- (1) The basic instrument is powered from L1, L2, L3 and N (4-wire version) or L1, L2, L3 (3-wire version). The presence of only one of the three phases (4-wire version) or two phases (3-wire version) ensures the normal counting and displaying operations.
- (2) The serial port is powered from L1 and N (4-wire version) or L1 and L2 (3-wire version). The communication function is ensured only if the L1 phase (or L1 and L2 for 3-wire) is present and within the specified range.

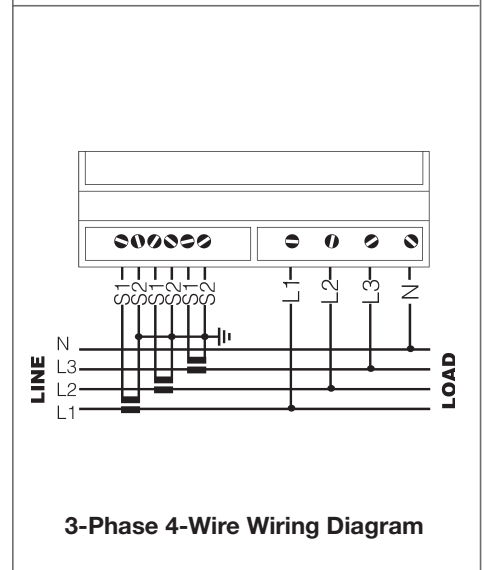
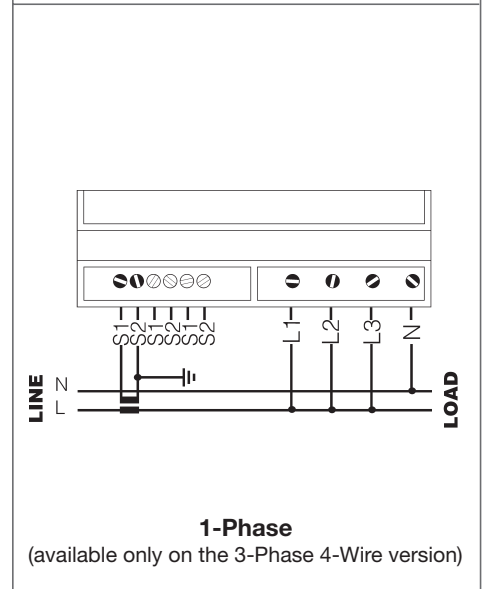
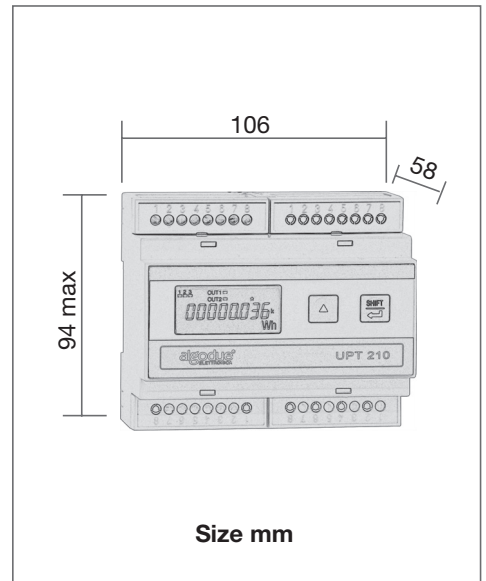

ORDERING INFORMATION

AUR A X X X X

UPT210

Series

Manual Language

D = German
I = Italian
U = English

Communication Protocol

X = None (without serial port)
B = ASCII STANDARD
C = MODBUS
L = LONBUS

Voltage Input

A = 3x230/400V_{AC} +15% -20% - 4 wires
B = 3x120/208V_{AC} +15% -20% - 4 wires
C = 3x400V_{AC} +15% -20% - 3 wires
D = 3x208÷230V_{AC} +15% -20% - 3 wires
E = 3x100÷120V_{AC} +15% -20% - 3 wires

Serial Port

X = None
5 = RS485

Memory

X = None

Firmware Options

A = Basic version - two quadrant measurement (1)
B = BIDIR - Bi-directional four quadrant measurements
C = PEAK - Peak values + demand calculation on power and current
D = BIDIR + PEAK

Other

2 = Basic version - Class 2
1 = ENH - Class 1

Inputs

X = None
5 = 25A - Direct connection up to 25A
P = RGW - Rogowski inputs 200A
T = RGW - Rogowski inputs 300A
U = RGW - Rogowski inputs 500A
R = RGW - Rogowski inputs 1000A
S = RGW - Rogowski inputs 3000A

Analog Outputs

X = None

Digital Outputs

2 = Basic version with No.2 on-board optoisolated outputs NPN type
3 = Basic version with No.2 on-board optoisolated outputs PNP type

Hardware Options

X = None

NOTES

(1) The basic instrument configuration includes:

- Voltage Input: A, B, C or D on request
- Mono-directional measurements (two quadrants) - Accuracy class 2
- Current Input: programmable 1/5ARMS. The CT value is programmable to 9999
- No. 2 optoisolated outputs (50V - 100mADC) for energy pulsing

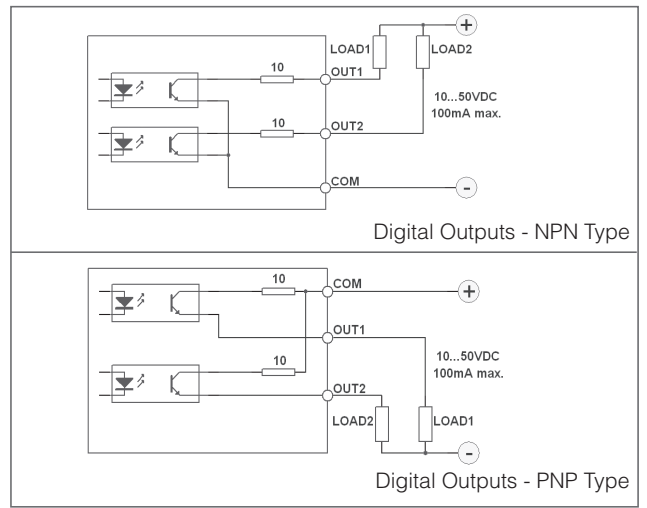

Subject to change without notice



ENERGY MEASUREMENT AND CONTROL

ALGODUE ELETTRONICA s.r.l.
Via Passerina, 3/A
28010 FONTANETO D'AGOGNA
(NO) ITALY

Tel: +39 0322 89864 - 89307
Fax: +39 0322 89871
E-mail: info@algodue.com
Website: www.algodue.com

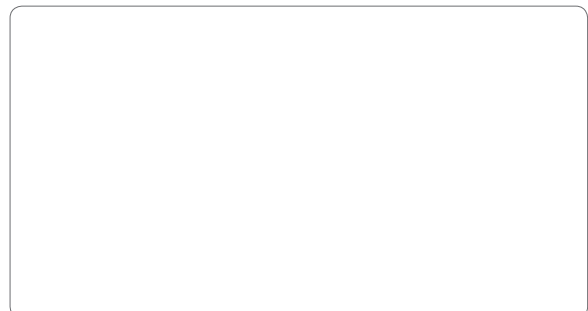

X-ON Electronics

Largest Supplier of Electrical and Electronic Components

Click to view similar products for [Digital Panel Meters](#) category:

Click to view products by [ALGODUE](#) manufacturer:

Other Similar products are found below :

[M00558-00](#) [01.098.1658.1](#) [70.360.4828.0](#) [72331-00](#) [85310-25](#) [86427-26](#) [86642-00](#) [87268-13](#) [87316-00](#) [87719-26](#) [98107-56](#) [HB8260-R36-90](#) [DMS-20ACV-3-R-C](#) [EM11DINAV81XR1X](#) [25.325.3253.1](#) [25.325.4253.1](#) [25.330.0453.1](#) [25.350.0553.0](#) [20046-20](#) [20182-23](#) [AP1020](#) [AP1021](#) [25.320.5053.0](#) [25.350.3453.1](#) [25.394.3653.1](#) [25.521.3253.0](#) [28006-01](#) [04.630.1080.0](#) [20078-20](#) [EM11DINAV81XO1X](#) [85874-26](#) [87166-00](#) [87895-00](#) [28000-03](#) [K3GN-NDT1-FLK 24VDC](#) [82322K-11](#) [86641-00](#) [87004-00](#) [MV15-DC-20V-110V-CU](#) [HB8260R4890](#) [20125-21](#) [86640-00](#) [2CMA100166R1000](#) [N27D 00M0](#) [DMG 100](#) [DMG 110](#) [DMG 800 L01](#) [DMK 01](#) [DMK 01 R1](#) [DMK 11](#)