

SOT-23 Plastic-Encapsulate Transistors

S8550 PNP Transistors

Features

- Complimentary to S8050
- Collector current: $I_C=0.8A$

Marking: 2TY

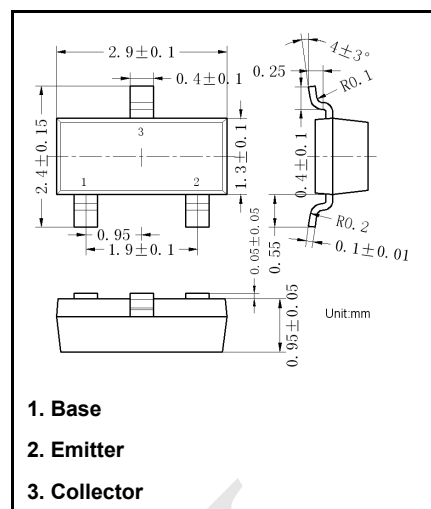

Maximum Ratings ($T_a=25^{\circ}C$ unless otherwise noted)

Symbol	Parameter	Value	Unit
V_{CBO}	Collector Base Voltage	-40	V
V_{CEO}	Collector Emitter Voltage	-25	V
V_{EBO}	Emitter Base Voltage	-5	V
I_C	Collector Current	-0.8	A
P_C	Collector Power Dissipation	300	mW
T_j	Junction Temperature	150	$^{\circ}C$
T_{stg}	Storage Temperature	-55 ~ +150	$^{\circ}C$

Electrical Characteristics ($T_a=25^{\circ}C$ unless otherwise specified)

Symbol	Parameter	Test Conditions	Min	Typ	Max	Unit
$V_{(BR)CBO}$	Collector-base breakdown voltage	$I_C = -100\mu A, I_E = 0$	-40			V
$V_{(BR)CEO}$	Collector-emitter breakdown voltage	$I_C = -10mA, I_B = 0$	-25			V
$V_{(BR)EBO}$	Emitter-base breakdown voltage	$I_E = -100\mu A, I_C = 0$	-5			V
I_{CBO}	Collector cut-off current	$V_{CB} = -40V, I_E = 0$	-100			nA
I_{CEO}	Collector cut-off current	$V_{CE} = -20V, I_B = 0$	-100			nA
I_{EBO}	Emitter cut-off current	$V_{EB} = -3V, I_C = 0$	-100			nA
$h_{FE(1)}$	DC current gain	$V_{CE} = -1V, I_C = -50mA$	160		320	
$h_{FE(2)}$		$V_{CE} = -1V, I_C = -500mA$	50			
$V_{CE(sat)}$	Collector-emitter saturation voltage	$I_C = -500mA, I_B = -50mA$			-0.6	V
$V_{BE(sat)}$	Base-emitter saturation voltage	$I_C = -500mA, I_B = -50mA$			-1.2	V
f_T	Transition frequency	$V_{CE} = -6V, I_C = -20mA, f = 30MHz$	150			MHz

Typical Characteristics

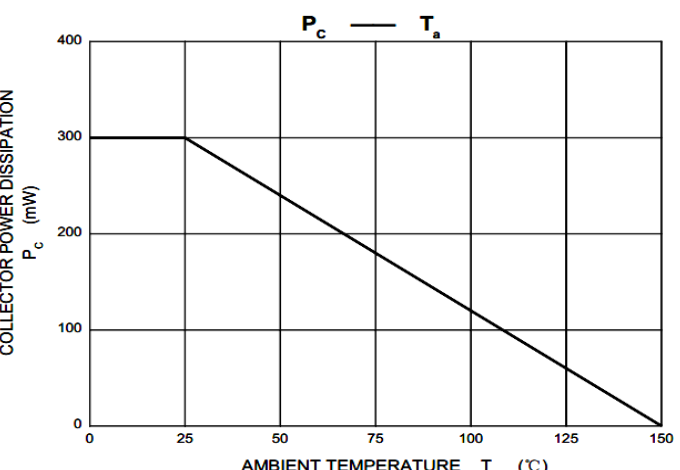
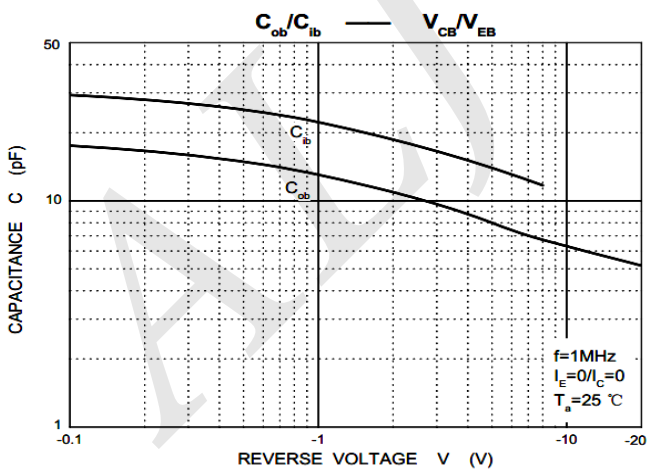
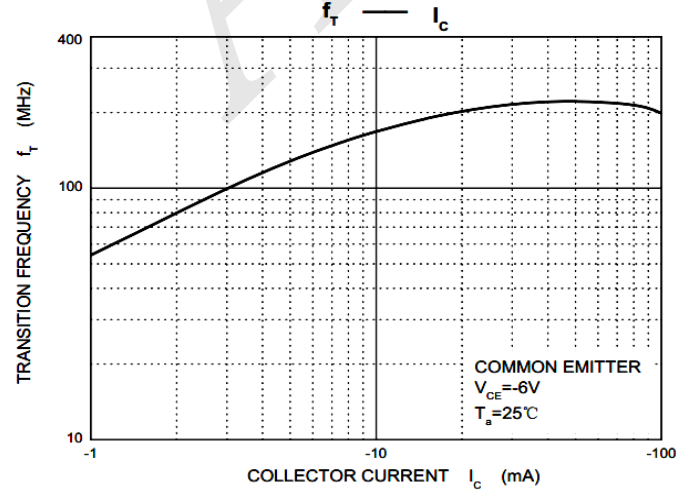
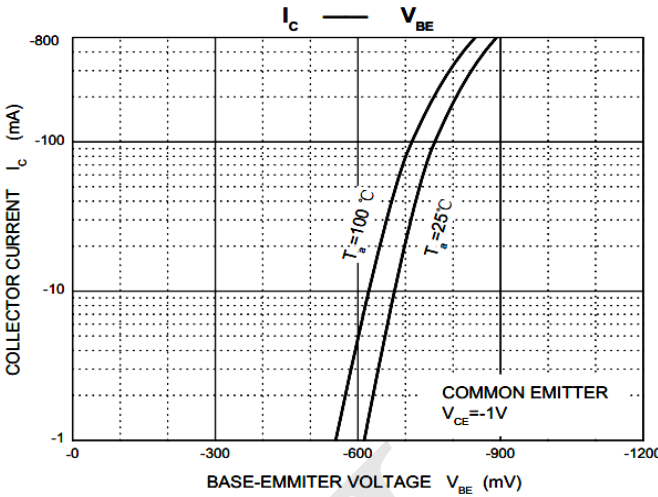
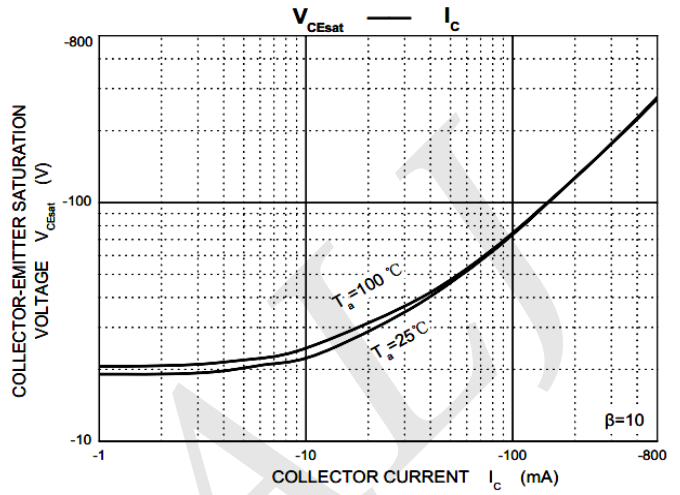
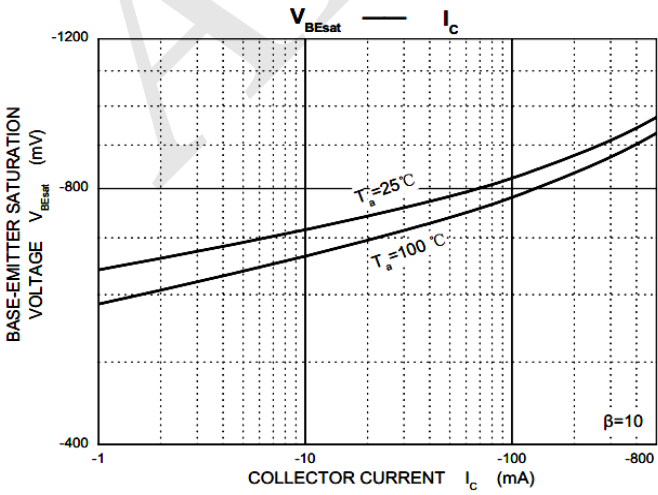
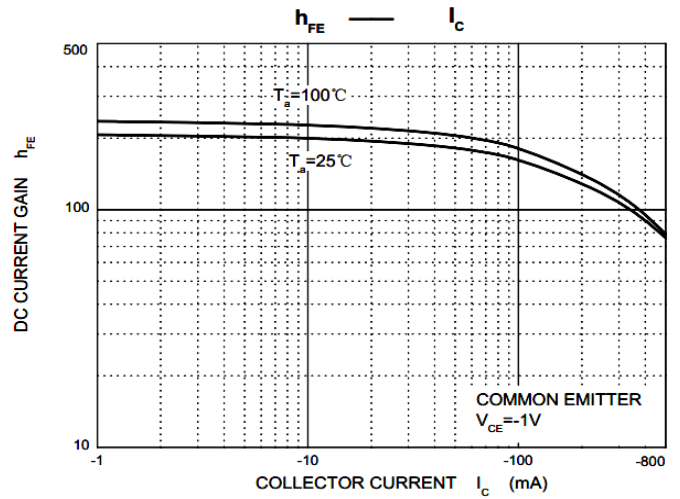
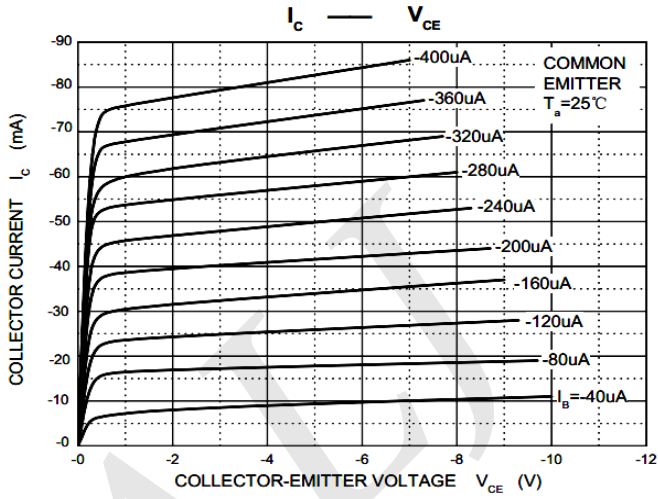

X-ON Electronics

Largest Supplier of Electrical and Electronic Components

Click to view similar products for [Bipolar Transistors - BJT category](#):

Click to view products by [ALJ manufacturer](#):

Other Similar products are found below :

[BC559C](#) [MCH4017-TL-H](#) [MMBT-2369-TR](#) [BC546/116](#) [NJVMJD148T4G](#) [NTE16](#) [NTE195A](#) [IMX9T110](#) [2N4401-A](#) [2N6728](#) [2SA1419T-TD-H](#) [2SB1204S-TL-E](#) [2SC5488A-TL-H](#) [FMC5AT148](#) [2N2369ADCSM](#) [2N2907A](#) [2N3904-NS](#) [2N5769](#) [2SC4618TLN](#) [CPH6501-TL-E](#) [BC856BW-13-F](#) [US6T6TR](#) [BAX18/A52R](#) [BC556/112](#) [IMZ2AT108](#) [MMST8098T146](#) [MCH6102-TL-E](#) [2N3879](#) [30A02MH-TL-E](#) [NTE13](#) [NTE282](#) [NTE323](#) [NTE350](#) [NTE81](#) [JANTX2N2920L](#) [JANSR2N2907AUB](#) [CMLT3946EG TR](#) [SNSS40600CF8T1G](#) [CMLT3906EG TR](#) [GRP-DATA-JANS2N2907AUB](#) [GRP-DATA-JANS2N2222AUA](#) [MMDT3946FL3-7](#) [2N4240](#) [JANS2N3019](#) [MSB30KH-13](#) [2N2221AUB](#) [2SD1815T-TL-E](#) [2N6678](#) [2N2907Ae4](#) [JAN2N3507](#)