

SOT-23 Plastic-Encapsulate Transistors

S9014 NPN Transistors

Features

- Complementary to S9015

Marking: J6

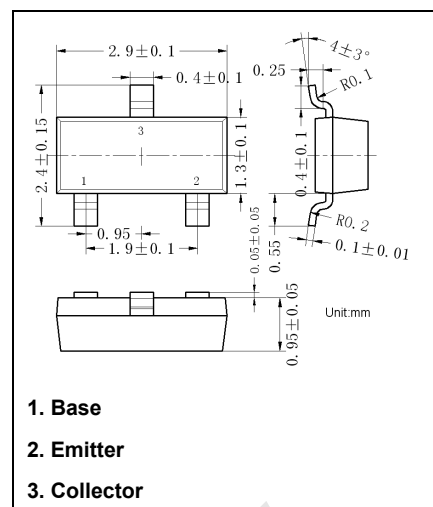

Maximum Ratings (T_a=25°C unless otherwise noted)

Symbol	Parameter	Value	Unit
V _{CBO}	Collector Base Voltage	50	V
V _{CEO}	Collector Emitter Voltage	45	V
V _{EBO}	Emitter Base Voltage	5	V
I _c	Collector Current	100	mA
P _c	Collector Power Dissipation	200	mW
T _j	Junction Temperature	150	°C
T _{stg}	Storage Temperature	-55 ~ +150	°C
R _{θJA}	Thermal Resistance from Junction to Ambient	625	°C/W

Electrical Characteristics (T_a=25°C unless otherwise specified)

Symbol	Parameter	Test Conditions	Min	Typ	Max	Unit
V _{(BR)CBO}	Collector-base breakdown voltage	I _c = 100μA, I _E = 0	50			V
V _{(BR)CEO}	Collector-emitter breakdown voltage	I _c = 0.1mA, I _B = 0	45			V
V _{(BR)EBO}	Emitter-base breakdown voltage	I _E = 100μA, d = 0	5			V
I _{CBO}	Collector cut-off current	V _{CB} = 50V, I _E = 0			0.1	μA
I _{CEO}	Collector cut-off current	V _{CE} = 50V, I _B = 0			1	μA
I _{EBO}	Emitter cut-off current	V _{EB} = 3V, I _C = 0			0.1	μA
h _{FE}	DC current gain	V _{CE} = 5V, I _c = 1mA	300		400	
V _{CE(sat)}	Collector-emitter saturation voltage	I _c = 100mA, I _B = 5mA			0.3	V
V _{BE(sat)}	Base-emitter saturation voltage	I _c = 100mA, I _B = 5mA			1	V
f _t	Transition frequency	V _{CE} =5V, I _c =10mA, f=30MHz	150			MHz

Typical Characteristics

Static Characteristic

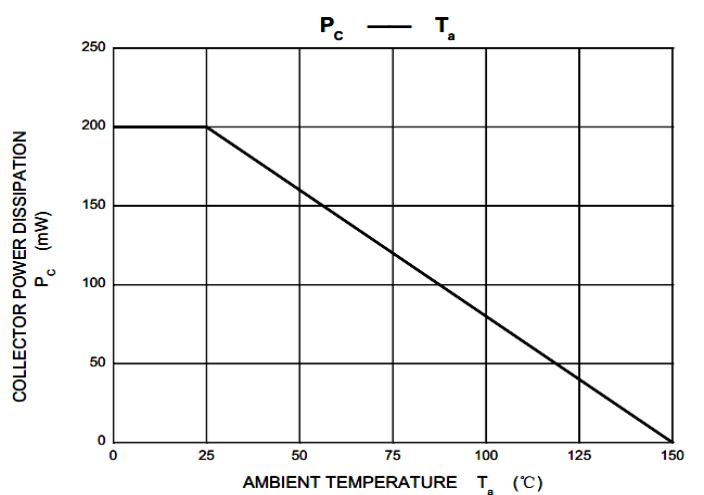
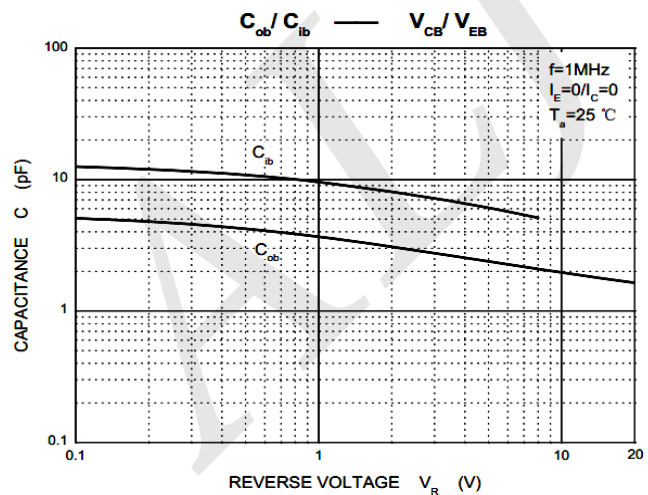
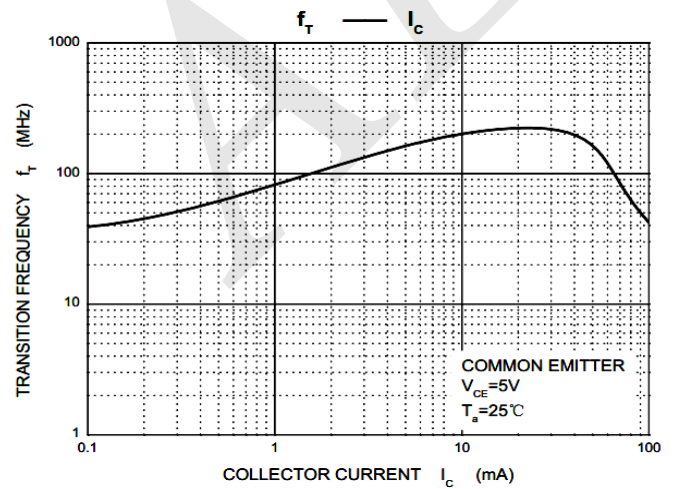
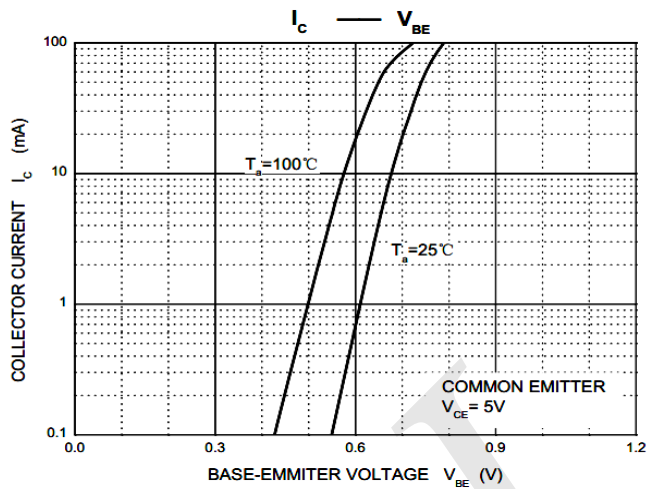
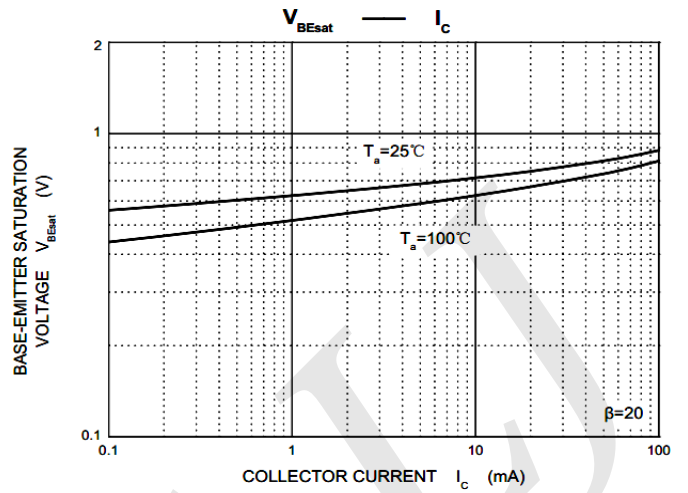
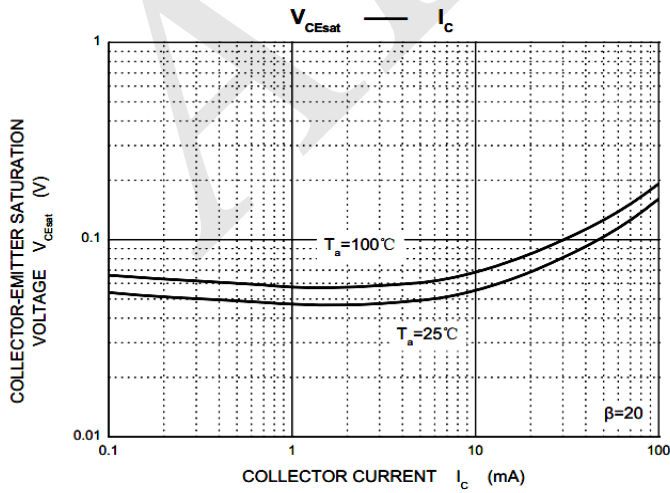
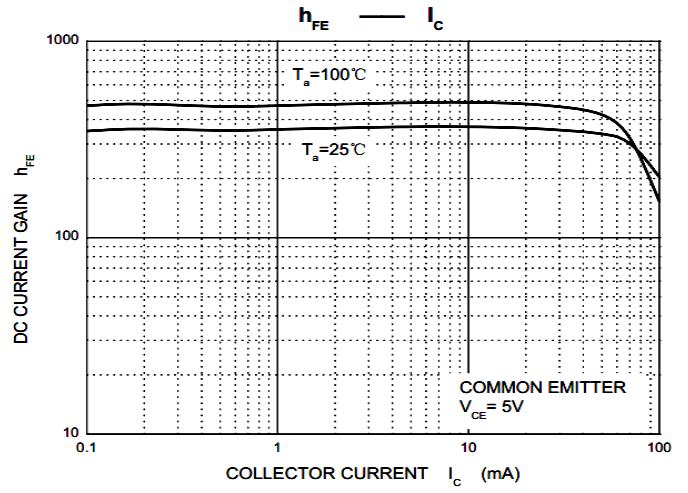
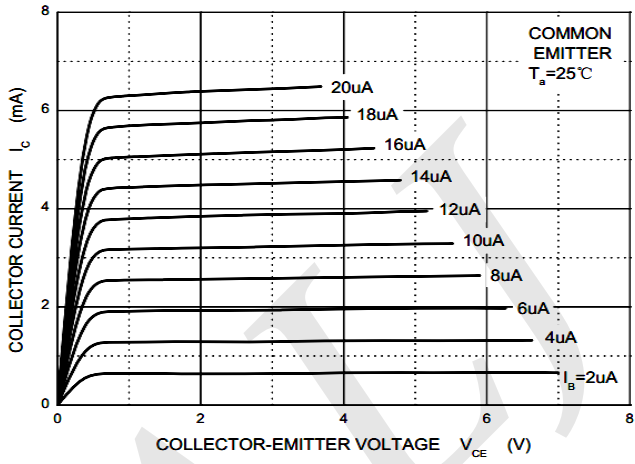

X-ON Electronics

Largest Supplier of Electrical and Electronic Components

Click to view similar products for [Bipolar Transistors - BJT category](#):

Click to view products by [ALJ manufacturer](#):

Other Similar products are found below :

[BC559C](#) [MCH4017-TL-H](#) [MMBT-2369-TR](#) [BC546/116](#) [NJVMJD148T4G](#) [NTE16](#) [NTE195A](#) [IMX9T110](#) [2N4401-A](#) [2N6728](#) [2SA1419T-TD-H](#) [2SB1204S-TL-E](#) [2SC5488A-TL-H](#) [FMC5AT148](#) [2N2369ADCSM](#) [2N2907A](#) [2N3904-NS](#) [2N5769](#) [2SC4618TLN](#) [CPH6501-TL-E](#) [BC856BW-13-F](#) [US6T6TR](#) [BAX18/A52R](#) [BC556/112](#) [IMZ2AT108](#) [MMST8098T146](#) [MCH6102-TL-E](#) [2N3879](#) [30A02MH-TL-E](#) [NTE13](#) [NTE282](#) [NTE323](#) [NTE350](#) [NTE81](#) [JANTX2N2920L](#) [JANSR2N2907AUB](#) [CMLT3946EG TR](#) [SNSS40600CF8T1G](#) [CMLT3906EG TR](#) [GRP-DATA-JANS2N2907AUB](#) [GRP-DATA-JANS2N2222AUA](#) [MMDT3946FL3-7](#) [2N4240](#) [JANS2N3019](#) [MSB30KH-13](#) [2N2221AUB](#) [2SD1815T-TL-E](#) [2N6678](#) [2N2907Ae4](#) [JAN2N3507](#)